



**SEA**

INNOVATIONS  
& EFFICIENCY



[sea.com.ua](http://sea.com.ua)



# About company



SEA Company was founded in 1990 in Kyiv



The company employs over 300 professionals



Quality management system of the company was approved to ISO 9001:2015



SEA Company has about 2000 m<sup>2</sup> of office space, its production and warehouse space exceeds 4000 m<sup>2</sup>



Supply of components and equipment from Europe, Asia, USA



Own electronics production



PCB design, manufacturing and commercial development services



Publishing house issues specialized international magazines, such as "Electric", "Radio components"





# Areas of specialization



## Distributions

Electronic components

Wireless products

Soldering devices and instruments

Measurement equipment

Power supplies

Electrical products

Industrial computers

Optoelectronics and LED products

Indicators, displays

Equipment for power engineering

Equipment for solar energy



## Products & Solutions

Traffic lights and LED traffic signals

Street light control system

Parking equipment and systems

Weigh-in-Motion systems

Elevator dispatching control system

System of remote water consumption metering

LED lighting solutions

LED displays

Universal uninterruptible power supply



## Services

Contract electronics manufacturing

Commercial developments

Design, installation, modernization, maintenance of parking complexes

Design, installation, maintenance of traffic light objects

Design, installation, maintenance of WIM objects



SEA Company is the official distributor  
of more than **70** world manufacturers



Direct shipments from more than  
**300** world manufacturers





# SEA Company provides direct supplies of components and equipment

For electronics development and production

- Electronic components
- Wireless products
- Optoelectronics
- Connectors
- AC / DC and DC / DC converters
- Soldering equipment for automatic and manual installation, high-quality assembly tools and technological materials
- Measuring instruments





## SEA Company provides direct supplies of equipment and accessories

For automation, electrical engineering, transport etc.

- Power supplies: AC / DC, DC / DC, DC / AC converters
- Charging devices
- Conductor and cable products

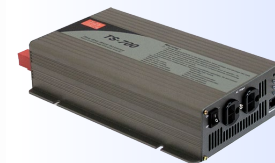



## SEA Company provides direct supplies of components and equipment

For lighting and advertisement information systems

- LED lighting products and optoelectronics: LEDs, LED matrices, modules and boards, secondary optics, reflectors and radiators, LED housing and other accessories
- Power supplies, drivers for LED products
- LED screens and media facades
- Video advertising equipment

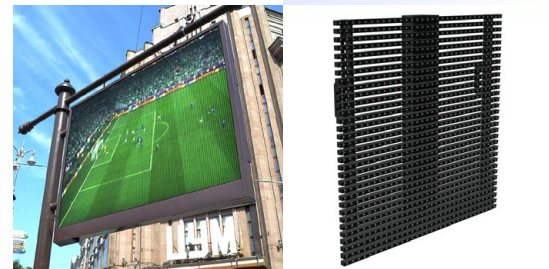
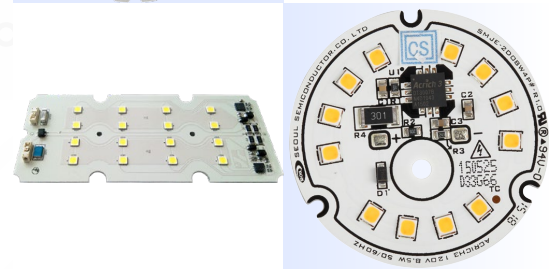
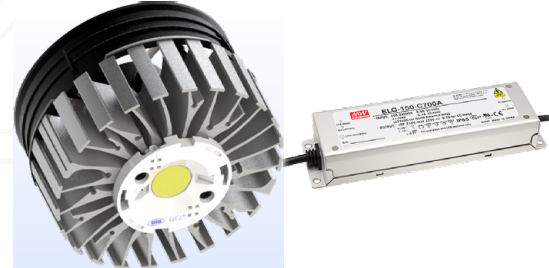



## SEA Company provides direct supplies of equipment

For electrical energy generation



S.E.A. SpA products:

- TTR cast resin dry-type transformers
- TTO, OTN, OTR and OTF oil-type transformers
- Current limiting reactors (CLR), earthing reactors and others
- TTH dry-type transformers with NOMEX insulation







# SEA Company provides direct supplies of equipment and accessories

## For solar energy (solar electric systems)

- Private use – on-grid, off-grid, hybrid type;
- Commercial application – ground, roof, facade mount.

- Invertors
- Connectors and fuses



EPVFL



EBPV4F-N



EMPVPCF4



EMPV4FC

- **SC-SP/11-24** power collection cabinets of solar photovoltaic module units

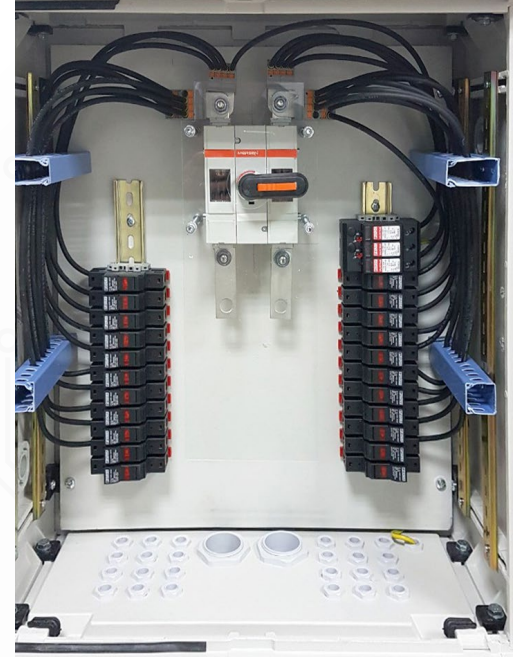



# SEA Company provides direct supplies of components and equipment

For automation, dispatching and engineering systems

- Industrial embedded computers and modules
- Data collection and management systems
- Industrial control systems (ICS)
- Man-machine interface systems (MMIS)
- Panel computers
- Touch screen monitors
- Rugged mobile computers
- Industrial workstations
- ICS components for e-mobility





# SEA Company provides direct supplies of products

## For electrical engineering

- DIN rail terminal blocks
- Marking systems
- Field wiring
- Surge protection and interference filters
- Relay modules
- Power supplies
- Industrial automation
- Wireless modules
- PCB terminal blocks and connectors
- Signal conditioners
- Valve connectors and cables
- Automatic and hand tools
- Product cases and accessories
- Low-voltage circuit breakers
- Contactors and relays
- Residual current circuit breakers
- Installation isolators





# SEA Company is a manufacturer of traffic lights and technical means for traffic control

Using a full complex of instrumentality for traffic regulation allows you to solve the problem of ensuring road safety.



LED traffic lights



Intelligent traffic lights controllers



LED traffic light countdown signs



Audible pedestrian signals

## Realized projects



*Mukachevo*



*Brovary*



*Novograd-Volynskiy*



*Boryspil*



# SEA Company is a manufacturer of LED variable message traffic signs

Multi-position controlled road signs are designed to inform road users about the conditions and driving regimes on public roads, streets and roads of urban and rural settlements.



## Completed projects



*Ternopil*

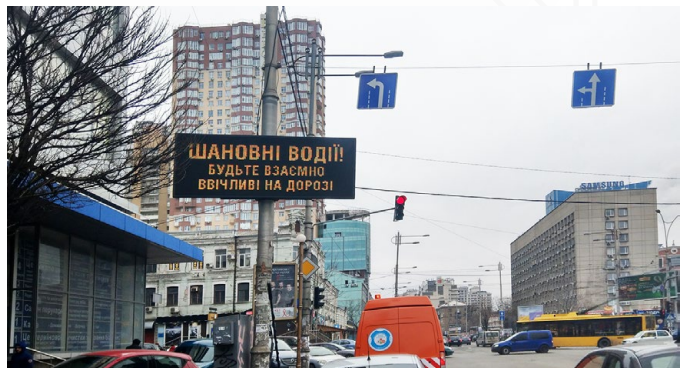

*Kyiv*



# SEA Company is a manufacturer of parking equipment and systems



**Parking equipment**



**Parking systems**



**Centralized network of paid parking**

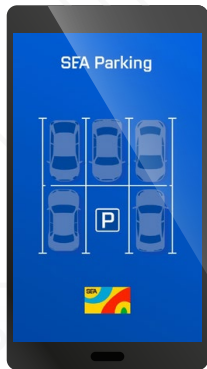

**SEA Parking user mobile app**

**Parking Inspector mobile app**



**Automated parking payment control system (APPCS)**



**Modernization and maintenance of parking lots**



# Completed SEA™ parking complex projects



**Airport parking systems**

**Parking lots with reversible entry / exit**



**Parking lots for hotels, shopping malls, business centers**

**Parking complexes for bus and train stations**

**Multilevel and underground parking**



## SEA Company is a manufacturer of LED displays

- Outdoor screens and video signboards
- Media facades
- Indoor displays
- Rental screens
- Displays for sports facilities
- Mobile double-sided screens

### Completed projects



*Kyiv, Stolychne highway, 103*



*Cherkasy,  
Budivelnik Sports Palace*



*Vinnitsia, Megamall shopping  
and entertainment center*





# SEA Company is a manufacturer of electrotechnical products



**Universal uninterruptible power supply**



**Automatic phase switches**



**Voltage monitoring relays**



**Lighting control cabinets I-710**



**Reactive power compensation devices**



# SEA Company is a manufacturer of LED printed circuit boards



495-560mm PCBs  
(Mid-power LEDs)

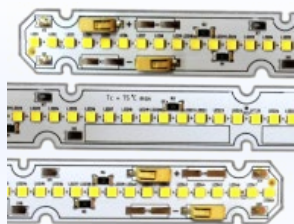

280mm PCBs  
(Mid-power LEDs)



Secondary PCBs  
(High-power LEDs)



Secondary PCBs  
(Mid-power LEDs)

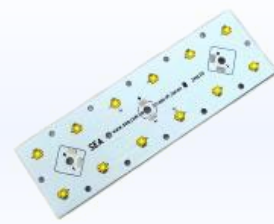

PCBs for IP-optics  
(High-power LEDs)

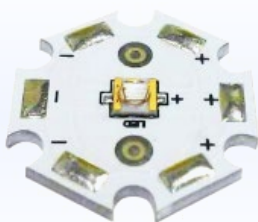

Star shaped PCBs  
(High-power LEDs)



PCBs for IP-optics  
(Mid-power LEDs)



495-560mm 12/24V PCBs  
(Mid-power LEDs)

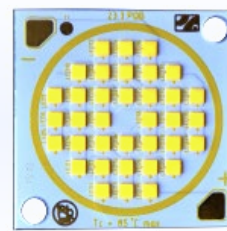

POB PCBs  
(package-on-board)

- LED modules of any power, color temperature and shape.
- Acrich MJT LEDs and microcircuits by Seoul Semiconductor are used.
- Built-in LED driver.
- Do not require additional power supplies.





Unified parking  
network system

Street lighting  
management system

Complex traffic control  
system  
monitoring and control  
of vehicles

Water distribution  
accounting and  
monitoring system  
water and sewage  
pumping stations,  
heating substations

Central  
citywide  
control room  
center

Dynamic weighing  
of vehicles in motion system

Energy resources accounting  
and monitoring system

Elevator  
dispatch system





# Design and installation of automated SEA™ systems

SEA Company develops projects for the implementation of automated intelligent SEA™ systems, as well as carries out the installation of:

- Traffic lights
- Automated traffic management systems
- Road information boards and variable-message signs
- Street lighting networks
- Street lighting control systems
- Elevator dispatching control systems
- Parking control systems

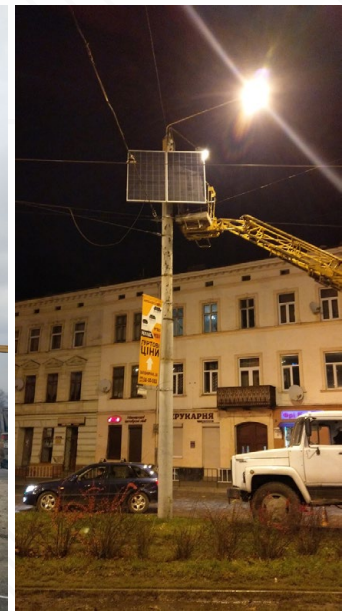
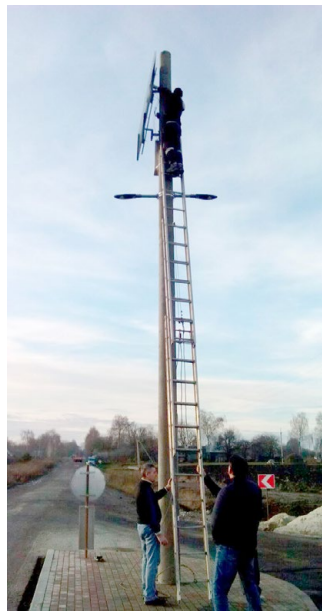
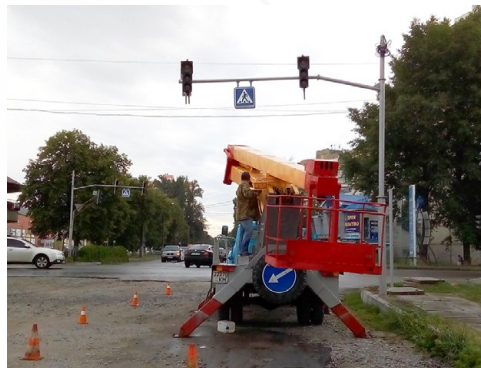



# Automated system of accounting and control of energy resources

SEA Company is a manufacturer and integrator of advanced electronic equipment and systems for urban infrastructure.



Water accounting system

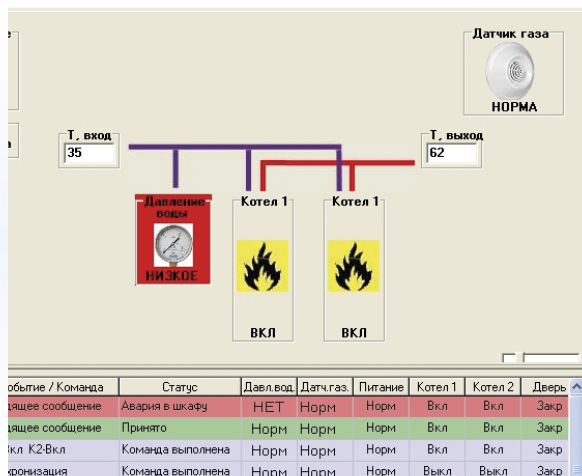

System heat supply dispatching control

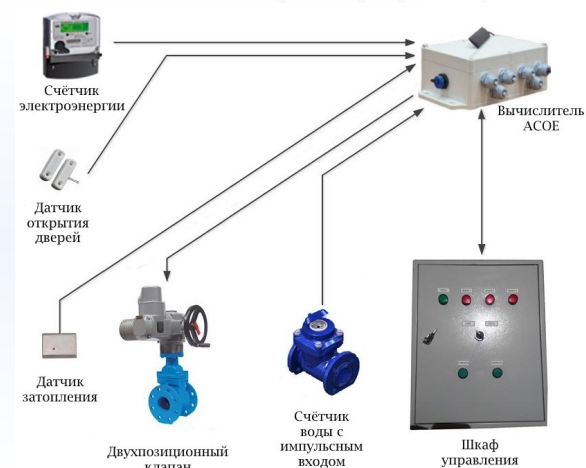

Dispatching system of pumping stations



# SEA™ elevator dispatching control system

Implementation of the adaptive algorithm ensures flexible use of GSM network resources and therefore, the ability to automatically optimize system operation in different modes of use.

## Basic functions of the system:



remote collection and visualization of data on elevator equipment status in real-time



communication between the control room and the elevator car, dispatching console and the machine room



control of local illumination of stairways



operational control of the main power contactor of the elevator station





# SEA™ street lighting control system

SEA Company offers a modern GSM technology based monitoring and management system for automation and dispatching of municipal outdoor lighting infrastructures.

## Basic functions of the system:



### Automatic control mode

is carried out on an individual schedule for each region



### Operational control mode

allows the dispatcher, if necessary, to manually control the devices of the power point





# SEA™ weigh-in-motion systems

SEA Company carries out the full scope of work for the implementation of Weigh-in-Motion (WIM) systems:

- individual design
- software development
- delivery and installation of equipment and supporting structures
- commissioning of the system and training of personnel
- technical support during the whole period of operation
- guaranteed high quality of equipment, software and provided services



Monitoring  
of road traffic



Vehicle pre-selection  
for control



Fixation of legal  
offences



Toll collection based  
on weight parameters



Protection  
of bridges





# SEA Company provides electronics manufacturing services

Provided services range from the development of printed circuit boards and the automatic installation of components on PCBs to the manufacture of final products.

SMD and DIP installation is carried out in accordance with international industry IPC / JEDEC standards, using high quality consumables and technological materials, modern automatic equipment and hand tools.



Quality management system of the enterprise is certified for compliance with the requirements of the international ISO 9001:2015 standard.

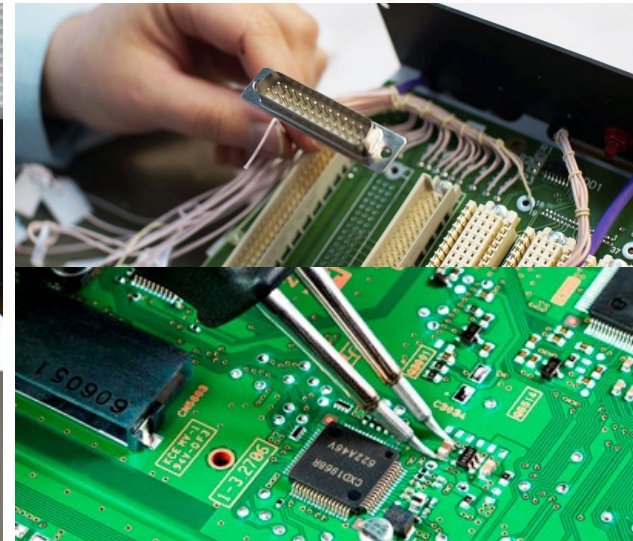



## SEA Company provides cable manufacturing services

Wire harnesses, ribbon cables and other connecting products of any complexity are made using specialized wire cutting / stripping and contact crimping equipment.





## SEA Company provides PCB manufacturing services

Custom printed circuit boards and stainless steel stencils of any complexity and batch size can be developed in the shortest possible time.

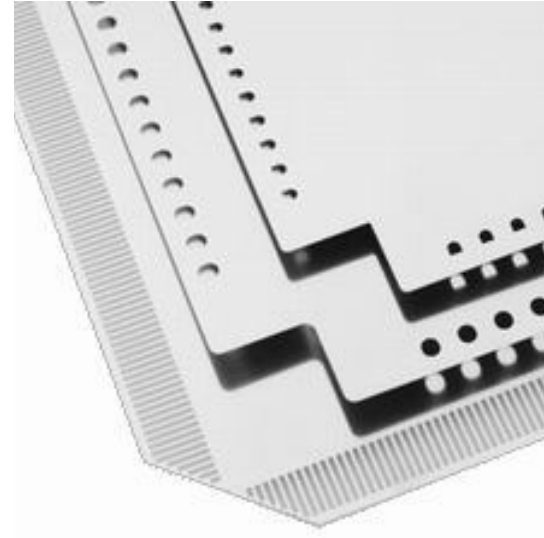
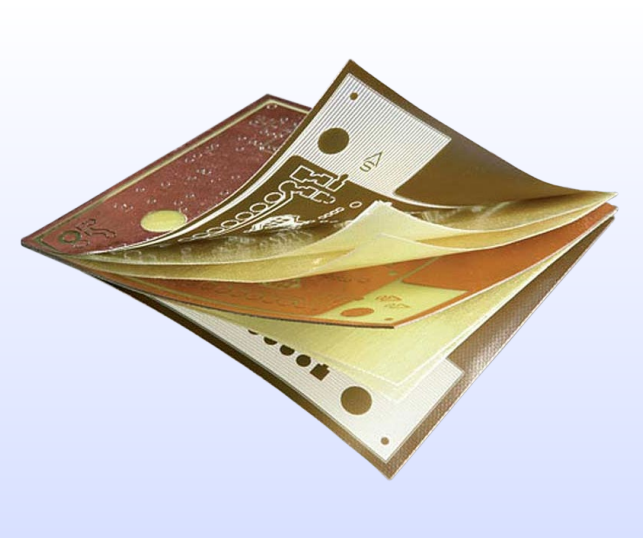



# Advantages of working with SEA Company



A wide range of goods and services – more than 50 000 items



Fast delivery of components and equipment from world manufacturers



Implementation of automated systems of our own production – flexible and modular



Contract production of electronics for the Ukrainian and foreign markets



Research conduction and release of serial and experimental batches



Free access of the customer to our production site for quick resolution of issues



Qualified consultations and prompt technical support



Development of optimal solutions with all necessary characteristics at a competitive price for the implementation of any tasks



Design, modernization and maintenance of equipment and systems



Automated supply, production and warehouse management system – certified according to ISO 9001:2015



Short lead times



Technical control of all finished products – guaranteed product quality

# Thank you for your attention



---

#13b, Krakivs'ka str.,  
Kyiv, 02094, Ukraine  
tel.: +38 (044) 330-00-88  
e-mail: info@sea.com.ua

[www.sea.com.ua](http://www.sea.com.ua)