



## ■ Features

- 2 kHz speed loop bandwidth
- 17-bit absolute encoder
- Adapt to multiple mainstream controllers
- Compact volume design meets the installation requirements of demanding spaces
- One click download and FOE function to improve production efficiency
- High quality motor bearings extend service life
- Stable operation in harsh environments
- CE certified to meet the export requirements for equipment

## ■ Applications

- Precision CNC Machine Tools
- Industrial Robots
- Semiconductor Manufacturing
- Intelligent Logistics Systems
- Automotive Manufacturing

## ■ Description

MD-730P series driver is designed for standard applications in various industries such as 3C, photovoltaics, batteries, packaging, and others. It has a rich range of driver products and accessories, making it easy to build the systems that customers need; By adopting new generation power devices and innovative designs, the required overall space has been significantly reduced, greatly improving the flexibility of the drive system layout. Excellent performance and multiple high-end features create faster, more stable, and more accurate driving scenarios, ensuring worry free production and providing efficient productivity for your enterprise.

## ■ Drive Model Encoding

**MD - 730 P S - 040**

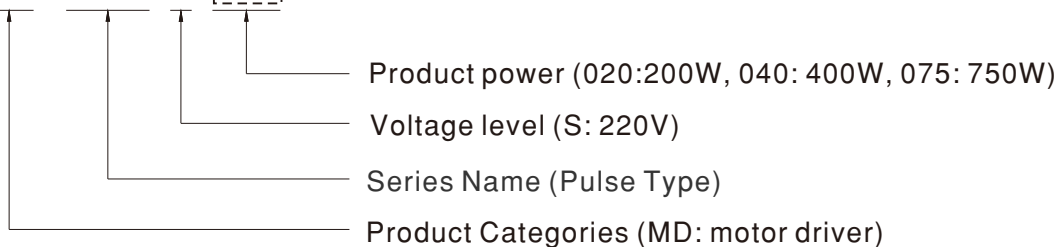



# Pulsed-Type Servo Drive System

# MD-730P series

Specification	MD-730PS-020	MD-730PS-040	MD-730PS-075
<b>Data</b>			
Driver power	0.2KW	0.4KW	0.75KW
OUTPUT	Continuous output current	1.6A	5.5A
	Maximum output current	5.8A	16.9A
INPUT	Main circuit power supply	Single-phase 200~240VAC, ±10%, 50/60Hz	
	Control circuit power supply	Powered up by the bus, sharing one power supply and rectification part with the main circuit	
Braking capability	External braking resistor		Built-in braking resistor
Control mode	IGBT PWM control, sine wave current drive mode		
	220 V, 380 V: Single-phase or three-phase full-bridge rectification		
Encoder feedback	17-bit multi-turn absolute encoder, which can be used as a single-turn absolute encoder in absence of the battery		
Communication Protocol	Modbus		
<b>Position control</b>			
Input pulse form	Including "direction+pulse", "Phase A + B quadrature pulse" and "CW/CCW pulse reference form"		
Input pulse frequency	Differential input: Up to 4 Mpps at high speed, and the pulse width cannot be less than 0.125 μs Open collector: Up to 200 kpps, and the pulse width cannot be less than 2.5 μs		
Multi-position reference	Position 0 to position 15 selectable through DI signal combination		
Output form	Phase A, phase B: differential output; Phase Z: differential output or open collector output		
<b>Speed/torque control mode</b>			
Speed control range	1:6000(The lower limit is the threshold within which the servo drive keeps running with the rated torque load.)		
Frequency characteristic	2kHz		
<b>Environment</b>			
Operating temperature	0~55°C		
Storage temperature	-40~70°C		
IP rating	IP20		
<b>SAFETY &amp; EMC</b>			
SAFETY STANDARDS	IEC 61800-5-1:2007; AMD1:2016		
EMC EMISSION	Parameter	Standard	Test Level / Note
	Conducted Emissions	EN IEC61800-3	Class A
	Radiated Emissions	EN IEC61800-3	Class A
	Voltage flicker	EN 61000-3-11 IEC 61000-3-11	-----
EMC IMMUNITY	Parameter	Standard	Test Level / Note
	ESD	IEC 61800-3, 61000-6-7	Level 3, 8KV air ; Level 2; 4KV contact
	EFT	IEC 61800-3, 61000-6-7	Level: 2KV
	Radiated	IEC 61800-3, 61000-6-7	
	Surge	IEC 61800-3, 61000-6-7	4KV/Line-Earth 2KV/Line-Line
	Conducted	IEC 61800-3, 61000-6-7	0.15 ~ 230MHz, 10V 80% AM(1KHz)
	THD	IEC 61800-3, 61000-6-7	12%
	Individual Harmonic orders	IEC 61800-3, 61000-6-7	Class 3
Voltage Dips and Interruptions	IEC 61800-3, 61000-6-7	Class 3 0,40%,70%,80%	
<b>OTHERS</b>			
PACKING	0.78kg		1.04kg
DIMENSION	40*161*150mm		50*161*174mm
<b>NOTE</b>			
1. Drives are only allowed to be operated in enclosed housings or control cabinets, and protective devices and covers must be installed 2. The driver can only be installed vertically, improper installation orientation may cause overheating. 3. Normal use conditions of this product: 30°C (annual average ambient temperature); The average load factor is less than 80%; Less than 20 hours of operation per day.			

## MD-K Series Servo Motor



## Motor Model Encoding

**MD - K S 2 6 S 3C 04**

- Power level (01:100W,02: 200W,04:400W,08:750W)
- Rated speed (3C: 3000rpm,C:\*10<sup>3</sup>)
- Brake and oil seal specification  
(N: no brake and oil sealing; S: no brake, with oil seal;  
C: with brake.no oil sealing; E:with brake and oil sealing)
- Shaft end specification (6: straight shaft, with keyway, threaded)
- Encoder type (2: 17 bit multi turn absolute value magnetic encoder)
- Voltage level (S:220V)
- Series Name
- Product Categories (MD: motor driver)

## MD-K Motor Torque Speed Characteristics

● 100W(40 frame)

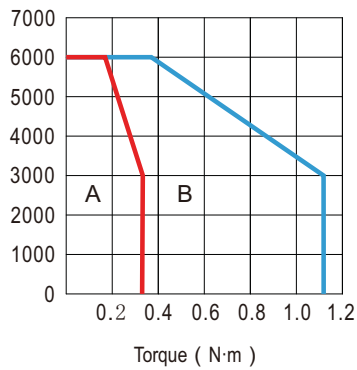

● 200W(60 frame)

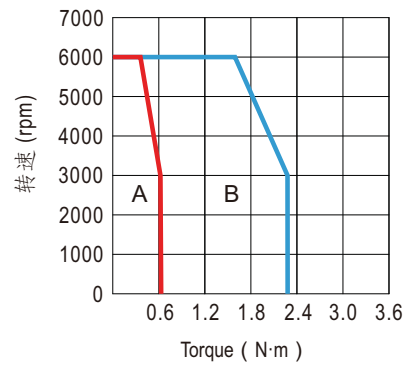

● 400W(60 frame)

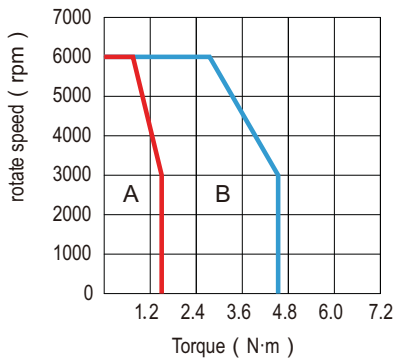

● 750W(80 frame)

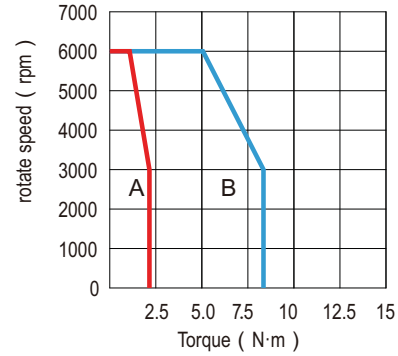

A — Continuous work area  
B — Short-term work area



Specification	MD-KS26N3C01	MD-KS26C3C01	MD-KS26S3C02	MD-KS26E3C02
<b>Technical Specifications</b>				
Rated power (W)	100		200	
Rated current (A)	1.1		1.29	
Maximum current (A)	3.9		4.41	
Rated torque (N·m)	0.32		0.64	
Maximum torque (N·m)	1.12		2.23	
Rotor inertia (10 kg <sup>4</sup> m <sup>2</sup> )	0.03	0.033	0.34	0.35
Overload multiplier	3.5			
Rated speed (rpm)	3000			
Maximum speed (rpm)	6000			
Flange size	40		60	
Rated voltage (V)	220			
Weight (kg)	0.4	0.6	0.8	1.2
<b>General Specifications</b>				
Duty	S1 (Continuous)			
Vibration class	V15			
Thermal class	Level F			
Insulation resistance	500VDC, above 10MΩ			
Excitation mode	Permanent magnetic			
Mounting mode	Flange			
Insulation voltage	1500 V AC, 1 minute (220 V level)			
Braking and maintenance	no brake and oil sealing	with brake.no oil sealing	no brake, with oil seal	with brake and oil sealing
<b>Safety &amp; EMC</b>				
SAFETY STANDARDS	IEC 60034-1:2022			
EMC EMISSION	Parameter	Standard	Test Level/Note	
	Conducted Disturbance	EN IEC 61000-6-4:2019	Class A	
	Radiated Electromagnetic Disturbance	EN IEC 61000-6-4:2019	Class A	
EMC IMMUNITY	Parameter	Standard	Test Level/Note	
	ESD	EN 61000-4-2:2009	Level 3,8KV air; Level 2,4KV contact	
	RF EM-Fields	EN 61000-4-3:2006+ A1:2008+A2:2010	Level 2,10V/m	
	Fast Transients	EN 61000-4-4:2012	Level 6KV	
	Surge	EN 61000-4-5:2014	Level 2,1KV/Line to Line; Level 3,2KV/Line-Earth	
	Injected Currents	EN 61000-4-6:2014	Level 2,3Vrms/m	
<b>Environment</b>				
Ambient temperature	0~40°C (Non-freezing)			
Ambient humidity	20%~80% (Non-condensing)			
Storage temperature	-20~+60°C (Non-freezing)			
Storage environment	20%~80% (Non-condensing)			
Insulation resistance	500VDC, above 10MΩ			
Shock resistance	490m/s <sup>2</sup> (5G)			
Vibration resistance	49m / s <sup>2</sup> (10G)			



Specification	MD-KS26S3C04	MD-KS26E3C04	MD-KS26S3C08	MD-KS26E3C08
<b>Technical Specifications</b>				
Rated power (W)	400		750	
Rated current (A)	2.51		4.60	
Maximum current (A)	8.78		16.30	
Rated torque (N·m)	1.27		2.39	
Maximum torque (N·m)	4.45		8.36	
Rotor inertia (10 kg <sup>4</sup> m <sup>2</sup> )	0.59	0.60	1.72	1.77
Overload multiplier	3.5			
Rated speed (rpm)	3000			
Maximum speed (rpm)	6000			
Flange size	60		80	
Rated voltage (V)	220			
Weight (kg)	1.1	1.5	2.2	2.8
<b>General Specifications</b>				
Duty	S1 (Continuous)			
Vibration class	V15			
Thermal class	Level F			
Insulation resistance	500VDC, above 10MΩ			
Excitation mode	Permanent magnetic			
Mounting mode	Flange			
Insulation voltage	1500 V AC, 1 minute (220 V level)			
Braking and maintenance	no brake, with oil seal	with brake and oil sealing	no brake, with oil seal	with brake and oil sealing
<b>Safety &amp; EMC</b>				
<b>SAFETY STANDARDS</b>	IEC 60034-1:2022			
<b>EMC EMISSION</b>	Parameter	Standard	Test Level/Note	
	Conducted Disturbance	EN IEC 61000-6-4:2019	Class A	
	Radiated Electromagnetic Disturbance	EN IEC 61000-6-4:2019	Class A	
<b>EMC IMMUNITY</b>	Parameter	Standard	Test Level/Note	
	ESD	EN 61000-4-2:2009	Level 3,8KV air; Level 2,4KV contact	
	RF EM-Fields	EN 61000-4-3:2006+ A1:2008+A2:2010	Level 2,10V/m	
	Fast Transients	EN 61000-4-4:2012	Level 6KV	
	Surge	EN 61000-4-5:2014	Level 2,1KV/Line to Line; Level 3,2KV/Line-Earth	
	Injected Currents	EN 61000-4-6:2014	Level 2,3Vrms/m	
<b>Environment</b>				
Ambient temperature	0~40°C (Non-freezing)			
Ambient humidity	20%~80% (Non-condensing)			
Storage temperature	-20~+60°C (Non-freezing)			
Storage environment	20%~80% (Non-condensing)			
Insulation resistance	500VDC, above 10MΩ			
Shock resistance	490m/s <sup>2</sup> (5G)			
Vibration resistance	49m / s <sup>2</sup> (10G)			

## Interface Description

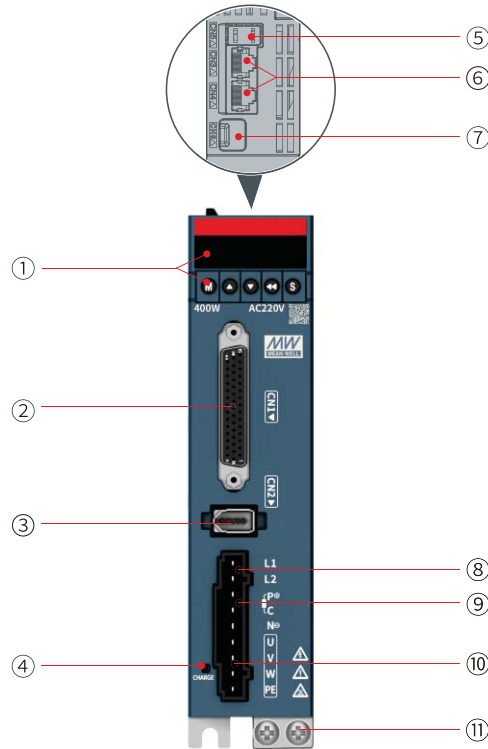



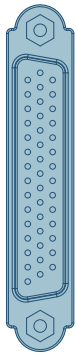

NO.	Name	NO.	Name
①	Display and operation area	⑦	Commissioning and communication port (CN6)
②	Control signal port (CN1)	⑧	Power input
③	Encoder signal port (CN2)	⑨	Braking resistor port
④	Charging indicator	⑩	Motor power output
⑤	STO terminal port (CN5)	⑪	System ground
⑥	Communication port (CN3 and CN4)		

## Terminal Definition

Terminal	Pin	Illustrate
	7	DO1+
	6	DO1-
	5	DO2+
	4	DO2-
	3	DO3+
	2	DO3-
	1	DO4+
	26	DO4-
	28	DO5+
	27	DO5-
	9	DI1
	10	DI2
	34	DI3
	8	DI4
	33	DI5
	32	DI6
	12	DI7
	30	DI8
	17	24V
	14	COM-
	11	COM+
	41	PULS+
	43	PULS-
	37	SIGN+
	39	SIGN-
	38	HPULS+
	36	HPULS-
	42	HSIGN+
	40	HSIGN-
	35	PULLH
	21	PAO+
	22	PAO-
	25	PBO+
	23	PBO-
	13	PZO+
	24	PZO-
	29	GND
	44	OCZ
	15	5V
	16	GND
	20	AI1
	18	AI2
	31	AO1
	19	GND

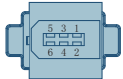

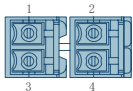
CN1 user control terminal

Terminal	Pin		Illustrate	
 CN2 encoder terminal	1	+5V	5V power supply	
	2	0V	0V power supply	
	3	Reserved		
	4	Reserved		
	5	PS+	Encoder signal+	
	6	PS-	Encoder signal-	
	Enclosure	PE	Shield	
 CN3 communication terminals	4	RS485+	Data transmit+	
	5	RS485-	Data transmit-	
	6	-		
	7	-		
	8	GND	Data receive-	
	Enclosure	PE	Shielding layer	
	 CN4 communication terminals	12	RS485+	Data transmit+
		13	RS485-	Data transmit-
14		-		
15		-		
16		GND	Data receive-	
Enclosure		PE	Shielding layer	
 CN5 STO function terminals		1	COM	STO reference ground
	2	24V	24V power supply	
	3	STO1	Control input for STO1	
	4	STO2	Control input for STO2	
 CN6 commissioning and communication terminal	Type-C		1: Type-C to serial, serial to USB 2: Type-C→USB	

## General specifications

Cable Type	Terminal Layout (Cable Side)	Pin No.	Usage
<p>Power input connector</p>		1	Phase V
		2	Phase U
		3	Phase W
		4	Grounding cable
		A	Brake (polarity insensi-tive)
		B	Brake (polarity insensi-tive)
<p>Encoder connector</p>		1	DATA+
		2	DATA-
		3	BAT+
		4	BAT-
		5	+5V
		6	0V
		7	Enclosure

## Mechanism Dimension

- 200W/400W

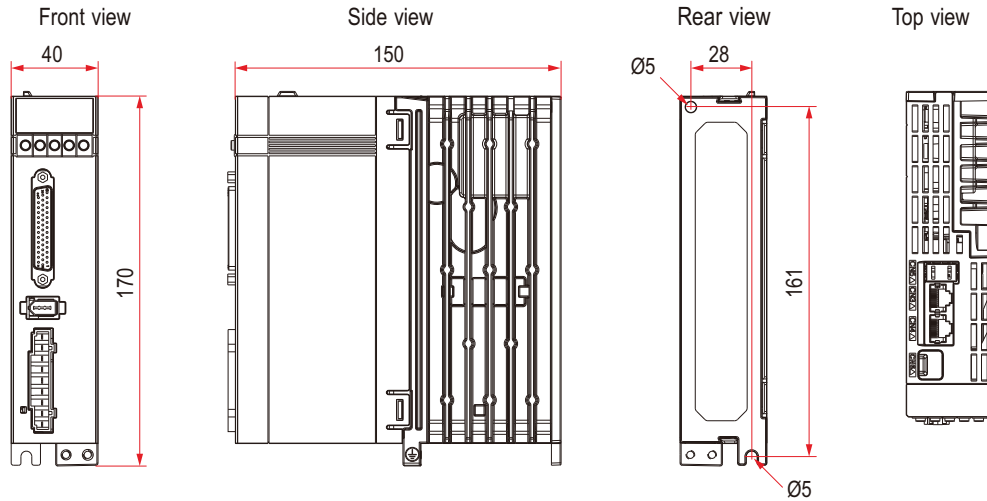

- 750W

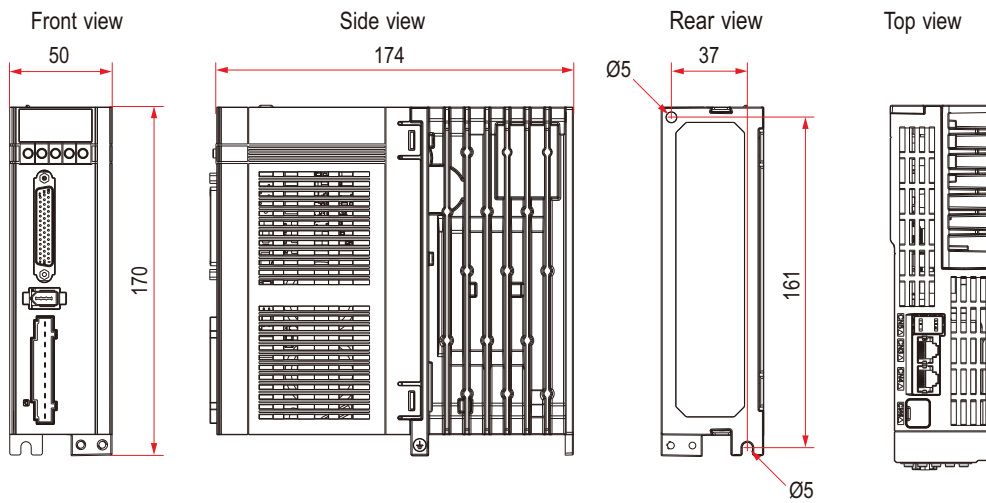

## Mechanism Dimension

### ● 100W(40 frame)

MD-KS26C3C01

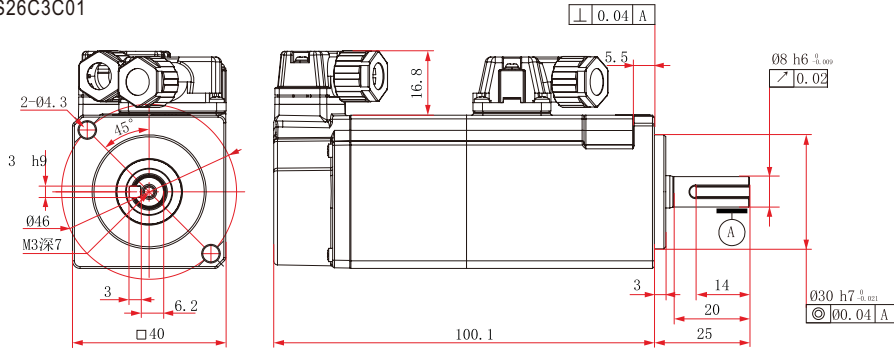

MD-KS26N3C01

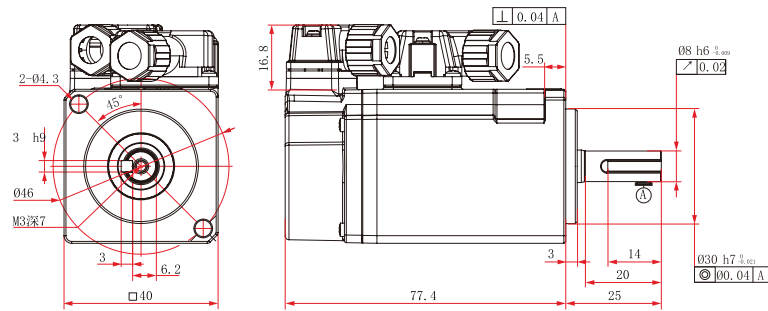

### ● 200W(60 frame)

MD-KS26E3C02

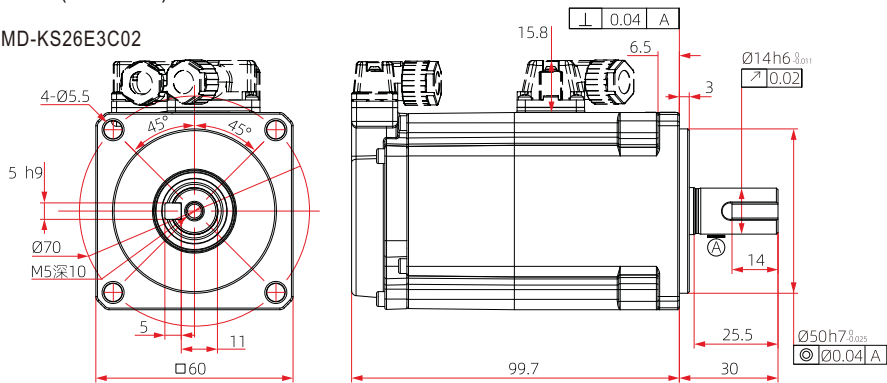

MD-KS26S3C02

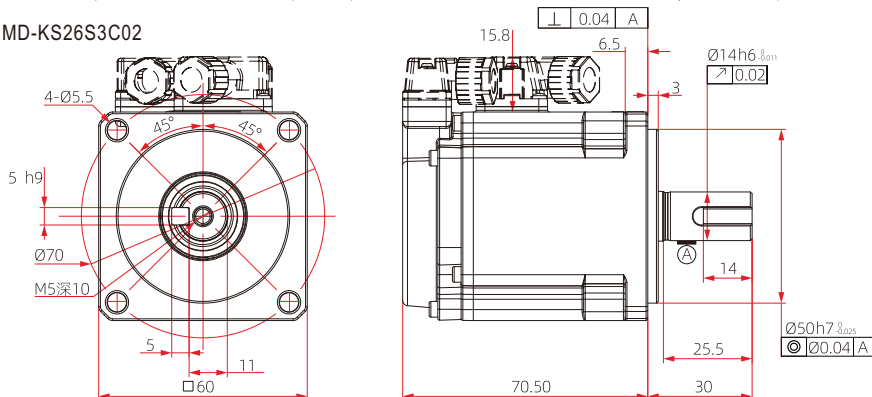

● 400W(60 frame)

MD-KS26E3C04

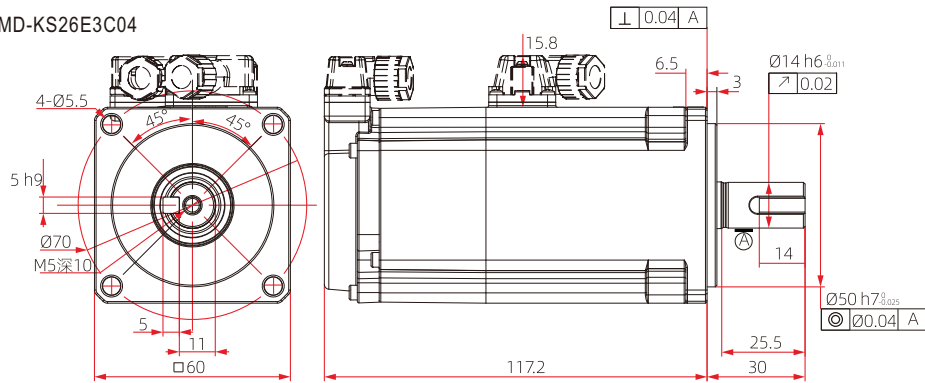

MD-KS26S3C04

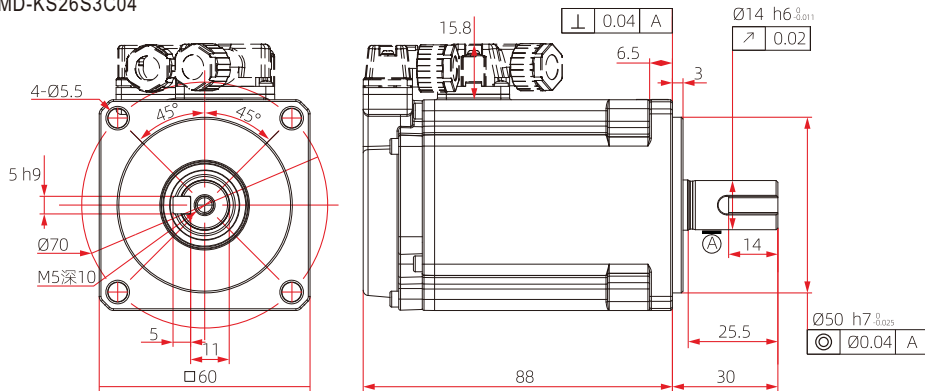

● 750W(80 frame)

MD-KS26E3C08

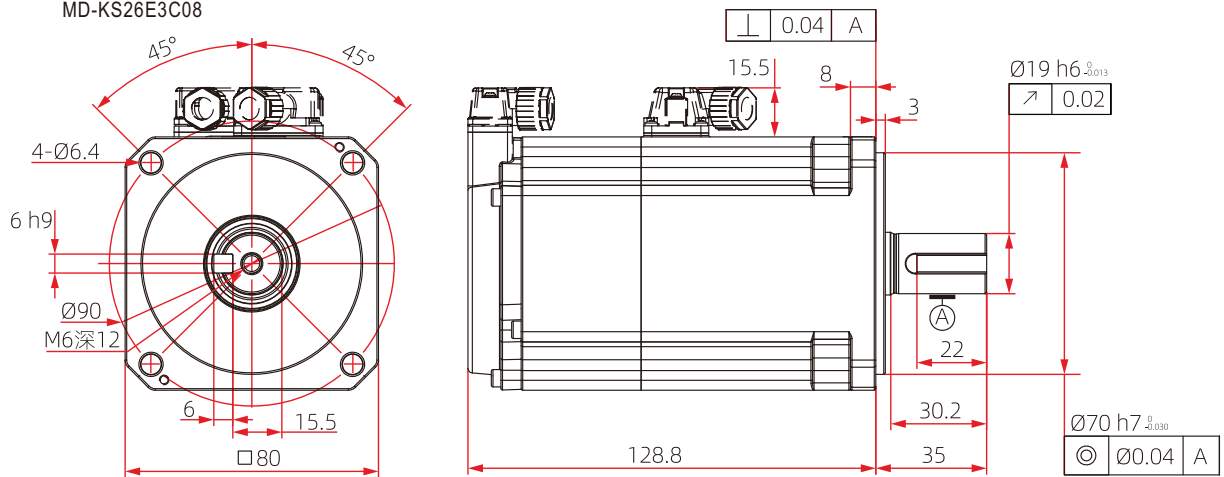

MD-KS26S3C08

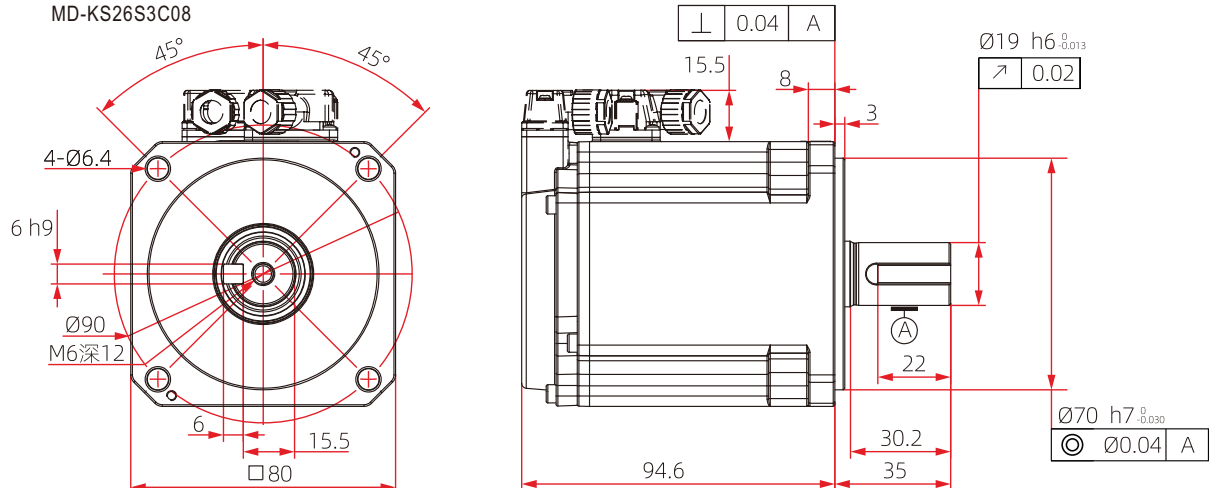

## Product Selection

### Driver & Motor Configuration Relationship

Driver Model	Motor model	Motor adaptation accessories		Brake Type
		Power cable model	Encoder cable model	
MD-730PS-020	MD-KS26N3C01	①	③	without brake
	MD-KS26C3C01	②		with brake
	MD-KS26S3C02	①		without brake
	MD-KS26E3C02	②		with brake
MD-730PS-040	MD-KS26S3C04	①	③	without brake
	MD-KS26E3C04	②		with brake
MD-730PS-075	MD-KS26S3C08	①	③	without brake
	MD-KS26E3C08	②		with brake

## Cable Information (to be ordered separately)

Name	Model	Length	Exterior drawing	number
Power Line	MD-PWCR0-3/5/10	3/5/10m		①
Power Line	MD-PWCB0-3/5/10	3/5/10m		②
Encoder line	MD-ENCC2-3/5/10	3/5/10m		③
DB15 Terminal fittings	MD-DB15	---	<p>Welded surfaces</p>	
DB44 Terminal fittings	MD-DB44	---	<p>Welded surfaces</p>	

Note: If you have other model needs, please contact MEAN WELL dealers.