



## ■ Features

- Universal AC input / Full range
- Built-in current sharing function
- With power good signal output
- Built-in active PFC function
- Low leakage current < 1.0mA
- Fanless design, Cooling by free air convection
- Protections: Short circuit / Overload / Over voltage / Over temperature
- 3 years warranty

## ■ Applications

- LED electronic signage
- LED display application
- LED luminous characters
- LED TV wall
- LED channel letter

## ■ Description

LHP-200 series is a 200W LED display power solution. The ultra low profile design that allows the height and weight of the sign module to be slim. It greatly simplifies the delivery and installation process. Accounting for high efficiency and energy saving, the series effectively achieves electricity reduction. It is suitable for LED signage display, moving sign, LED channel letter and LED TV wall etc.

## ■ Model Encoding

LHP - 200 - 5

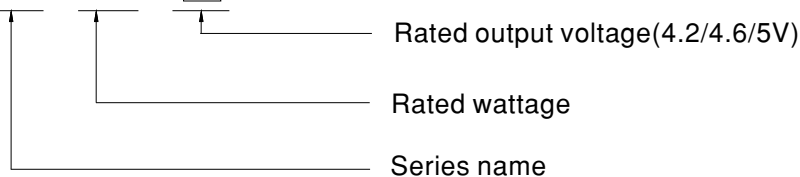



**SPECIFICATION**

MODEL		LHP-200-4.2	LHP-200-4.6	LHP-200-5
OUTPUT	DC VOLTAGE	4.2V	4.6V	5V
	RATED CURRENT	40A	40A	40A
	RATED POWER(convection)	168W	184W	200W
	RIPPLE & NOISE (max.) Note.2	200mVp-p	200mVp-p	200mVp-p
	VOLTAGE RANGE	3.8~4.2V	4.2~4.6V	4.5~5V
	VOLTAGE TOLERANCE Note.3	±5.0%		
	LINE REGULATION	±1.0%		
	LOAD REGULATION	±1.0%		
	SETUP, RISE TIME	2000ms, 100ms / 230VAC at full load		
	HOLD UP TIME (Typ.)	10ms/230VAC 10ms/115VAC		
INPUT	VOLTAGE RANGE Note.4	90 ~ 264VAC		
	FREQUENCY RANGE	47 ~ 63Hz		
	POWER FACTOR (Typ.)	PF ≥ 0.95 / 230VAC at full load		
	EFFICIENCY (Typ.)	90%	91%	91%
	AC CURRENT (Typ.)	2.2A/115VAC 1.1A/230VAC		
	INRUSH CURRENT (Typ.)	Cold start 40A/115VAC 80A/230VAC		
	LEAKAGE CURRENT	<1.0mA / 240VAC		
PROTECTION	SHORT CIRCUIT	Protection type : recovers automatically after fault condition is removed		
	OVER CURRENT	125 ~ 175% rated output power Protection type : Hiccup mode, recovers automatically after fault condition is removed		
	OVER VOLTAGE	5.5~ 6V Protection type :Shut down O/P voltage, with auto-recovery		
	OVER TEMPERATURE	Protection type :Shut down O/P voltage, recovers automatically after temperature goes down		
	FUNCTION	POWER GOOD	2.3~3.3V	
ENVIRONMENT	WORKING TEMP.	-40 ~ +80°C (Refer to "Derating Curve")		
	STORAGE TEMP., HUMIDITY	-40 ~ +90°C, 5~ 95% RH non-condensing		
	TEMP. COEFFICIENT	±0.02%/°C (0 ~ 50°C)		
	VIBRATION	1 ~ 200Hz, 2G 10min./1cycle, period for 30min. each along X, Y, Z axes		
SAFETY & EMC (Note.6)	SAFETY STANDARDS	UL60950-1,EN60950-1,CCC GB4943.1 approved		
	WITHSTAND VOLTAGE	I/P-O/P:3.0KVAC I/P-FG:1.5KVAC O/P-FG:0.5KVAC		
	ISOLATION RESISTANCE	I/P-O/P, I/P-FG,O/P-FG: ≥ 10M Ohms/500VDC/25°C / 70%RH		
	EMC EMISSION	Compliance to EN55032,GB/T9254 Class B,EN61000-3-2,EN61000-3-3,GB17625.1		
	EMC IMMUNITY	Compliance to EN55024,EN61000-4-2,3,4,5,6,8,11;		
OTHERS	MTBF	100K hrs min. MIL-HDBK-217F (25°C)		
	DIMENSION	220*50*26mm (L*W*H)		
	PACKING	0.39kg;30pcs/13.82kg/0.69CUFT		
NOTE	<p>1. All parameters NOT specially mentioned are measured at 230VAC input, rated load and 25°C of ambient temperature.                  2. Ripple &amp; noise are measured at 20MHz of bandwidth by using a 12" twisted pair-wire terminated with a 0.1uf &amp; 47uf parallel capacitor.                  3. Tolerance :includes set up tolerance, line regulation and load regulation.                  4. Derating may be needed under low input voltages. Please check the derating curve for more details.                  5. The ambient temperature derating of 5°C/1000m is needed for operating altitude greater than 2000m(6500ft)                  6. The power supply is considered a component which will be installed into a final equipment. The final equipment must be re-confirmed that it still meets EMC directives. For guidance on how to perform these EMC tests, please refer to "EMI testing of component power supplies." (as available on <a href="http://www.meanwell.com">http://www.meanwell.com</a>)</p>			

## Block Diagram

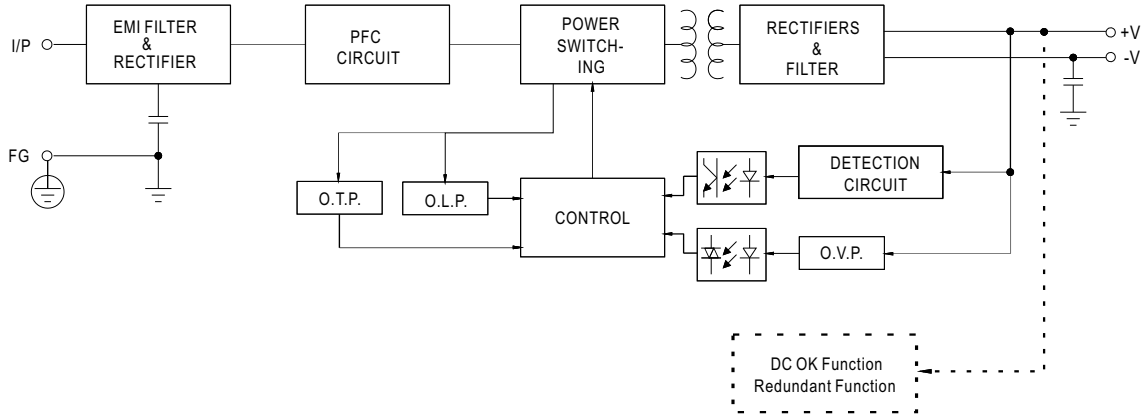

## OUTPUT LOAD vs TEMPERATURE

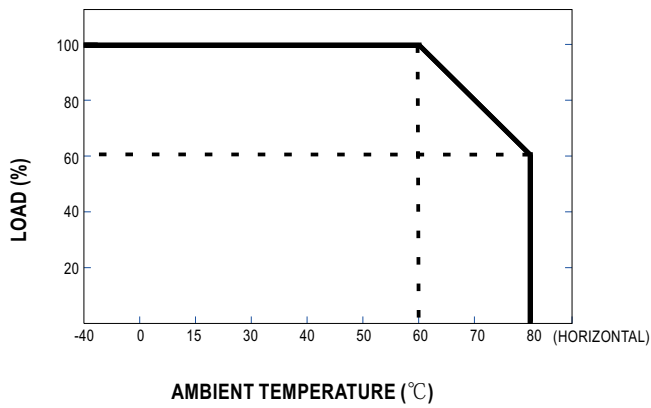

## STATIC CHARACTERISTIC

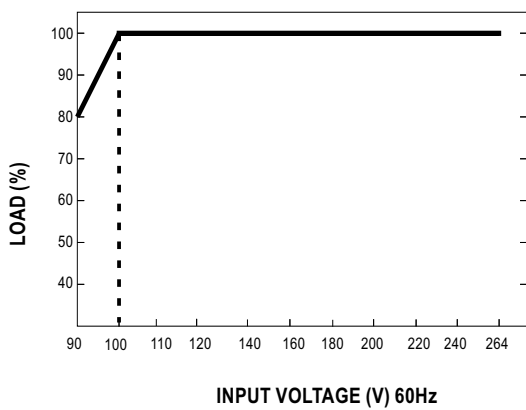

## ■ Function Manual

### 1.Redundant function

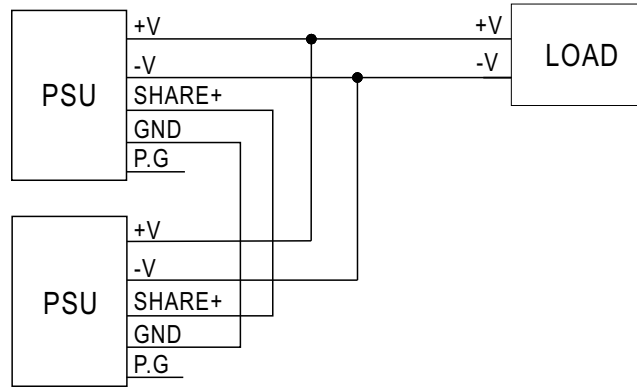

■ Mechanical Specification

Unit:mm

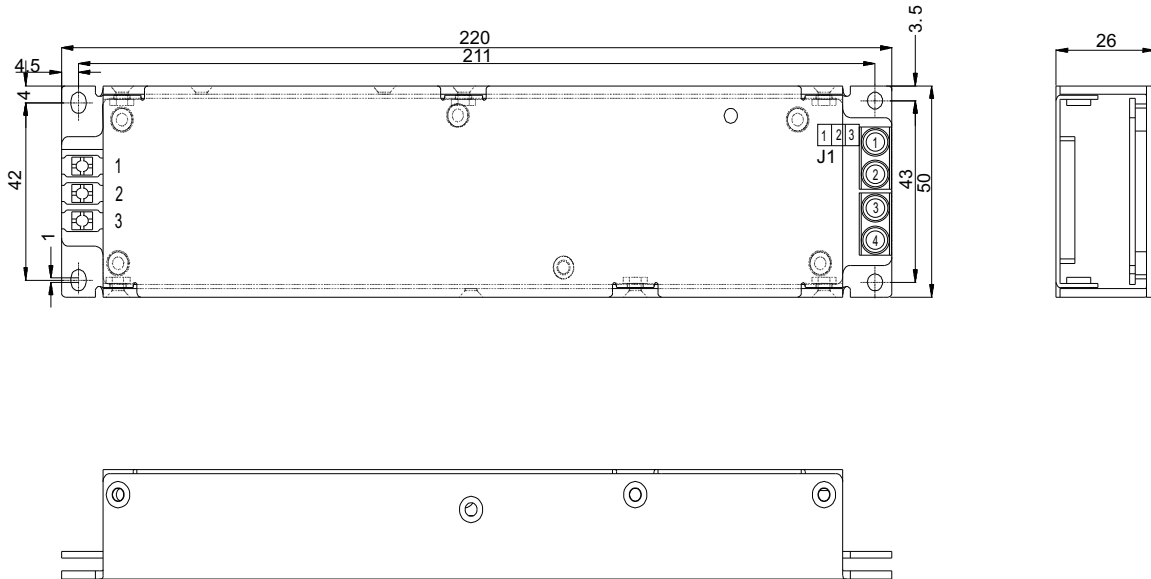

AC Input Terminal pin NO. Assignment

Pin No.	Assignment	Terminal	Max mounting torque
1	⏏	(Elinker) LW1C-8.25-3P-130-04A	5Kgf-cm
2	AC/N		
3	AC/L		

DC Output Terminal pin NO. Assignment

Pin No.	Assignment	Terminal	Max mounting torque
1,2	+V	(Elinker) LW1B-8.25-6P-130-05A	5Kgf-cm
3,4	GND		

Function Connector(J1)

Pin No.	Assignment	Terminal
1	SHARE	JIESHITAI A2001A-03-A1MA-P-D
2	GND	
3	PG(Power Good)	

**■ Installation**

## 1. Operate with additional aluminum plate

In order to meet the "Derating Curve" and the "Static Characteristics", LHP-200 series must be installed onto an aluminum plate (or the cabinet of the same size) on the bottom. The size of the suggested aluminum plate is shown as below. And for optimizing thermal performance, the aluminum plate must have an even and smooth surface (or coated with thermal grease), and LHP-200 series must be firmly mounted at the center of the aluminum plate.

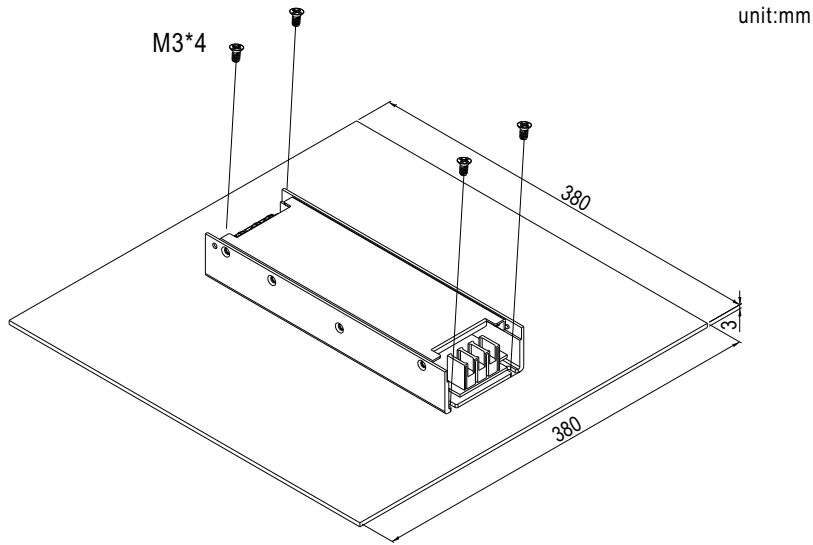

2. For heat dissipation, at least 5cm installation distance around the PSU should be kept, shown as below:

