

2025 | Household/Building Technology Product Portfolio

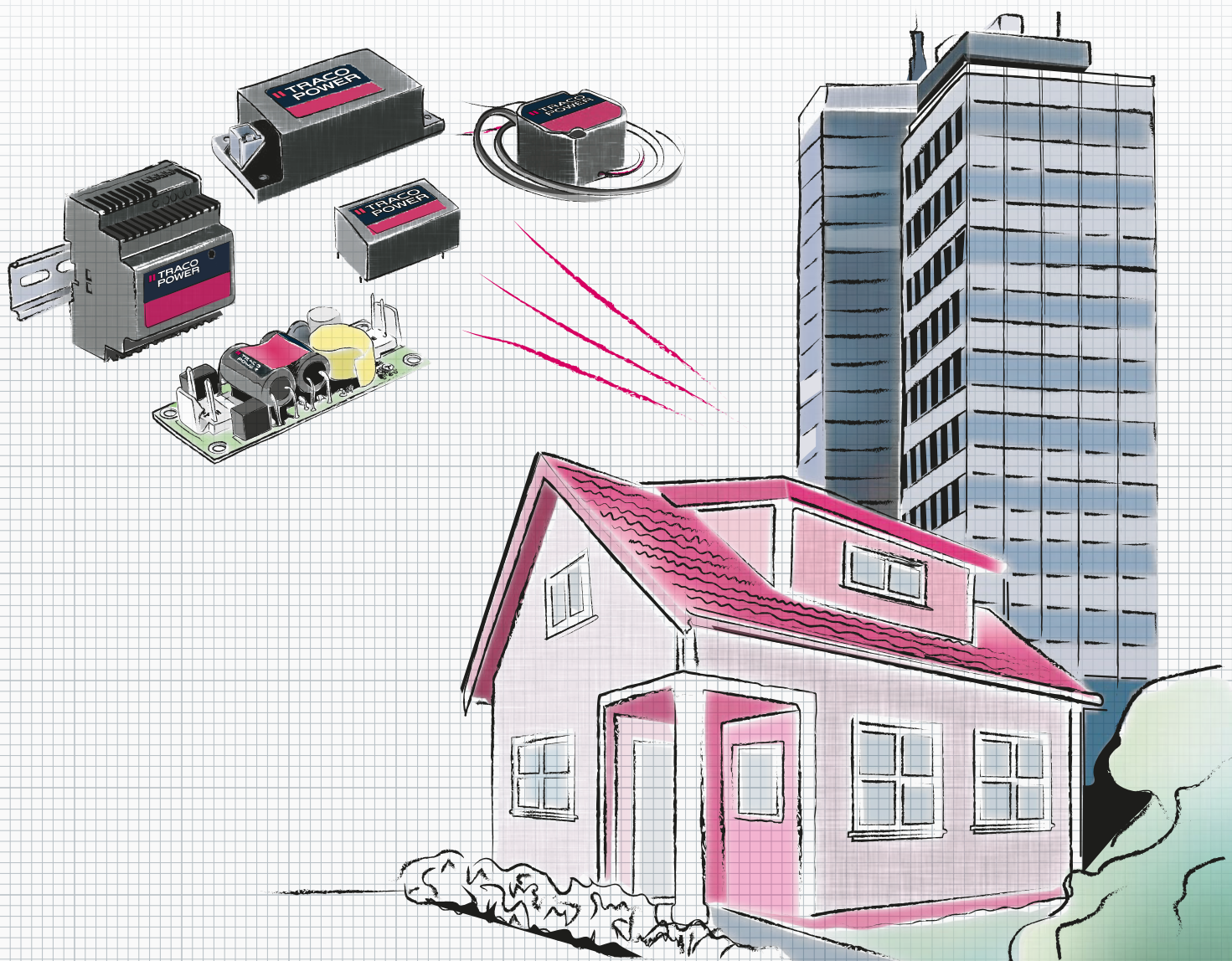

Company Profile

TRACO Electronic AG is a Swiss company with headquarters based in Baar, Switzerland. As a leading power supply specialist with more than 40 years experience we are dedicated to the design and manufacturing of high quality DC/DC and AC/DC power conversion products.

TRACO markets its products worldwide under the registered trademark TRACO POWER. Our mission is to provide our customers with optimal power supply solutions in terms of performance, quality and cost for their individual application.

AC/DC Power Supplies for Household, Smart Buildings & Office Applications

AC/DC power supplies for household, smart buildings and office applications comply with stringent regulatory requirements including the internationally recognized **EN 60335-1** standard for electrical appliances for households. As an integral part of today's and tomorrow's building infrastructure, our AC/DC power supplies are designed for lowest standby power consumption, lowest low-load power losses and highest peak power conversion efficiency, resulting in lowest total cost of ownership.

Traco Power has over two decades of experience in developing optimized AC/DC power supplies for household, smart buildings and office applications. Our product range includes AC/DC power supplies from 3–240 watt.

Key Features

- Ultra-low standby/low-load power consumption compliant with ErP directive
- Universal or extended input voltage range
- Power conversion efficiency up to 94%
- Compact designs with highest power density
- Protection class II prepared
- Outlet box and flush box mountable solutions for smart home and IoT applications available
- DIN-Rail mountable solutions for building automation requirements (depth 55 mm max) available

Household & Building Automation Products Meet the Following Standards

- Electrical appliances for households EN 60335-1
- IT equipment IEC/EN/UL 62368-1
- ErP complaint with ultra-low standby/no load power consumption
- UL 1310 class II/NEC class 2 compliance
- EN 55032 conducted & radiated emissions level B

Customized Solutions

Do you have trouble finding a standard AC/DC power supply that meets your specific application requirements without unnecessary and expensive additional features? With over 30 years of experience in designing standard and custom AC/DC power supplies and DC/DC converters, our design teams at TRACO POWER SOLUTIONS are dedicated to developing the product you truly need at the price you truly want.

Visit <https://www.tracopower.com/development-customization-center> for more information.



3-240 Watt AC/DC Power Supplies

Key Features

- Universal/ extended input voltage range
- Ultra-low standby power consumption
- Power-conversion efficiency up to 94%
- Protection class II prepared

Standards and Directives

- EN 60335-1
- IEC/EN/UL 62368-1
- ErP directive

Available Form Factors

- Open-frame
- Fully encapsulated PCB mountable
- DIN-rail mountable
- Mountable in wall outlet boxes

Household & Building Technology AC/DC Power supplies

Encapsulated



3 – 100 W

Open Frame



15 – 30 W

DIN-Rail



6 – 240 W

PERFORMANCE IN WATTS

3

100

200

250



Index

Household & Building Automation AC/DC Power Supplies (PCB, Outlet box, Chassis Mounting)

	W × L	Mounting	Housing	Input	I/O isolation		
TMPS 03	1" × 1"	PCB	Encapsulated	85–264 VAC	3000 VAC	3 watt	6
TMPS 05	1" × 1"	PCB	Encapsulated	85–264 VAC	3000 VAC	5 watt	7
TMPW 5	1.46" × 1.08"	PCB	Encapsulated	90–305 VAC	4000 VAC	5 watt	7
TMPW 5-J/-T	2.17" × 1.08"	Chassis	Encapsulated	90–305 VAC	4000 VAC	5 watt	8
TIW 6/12	2.2" × 2.2"	Outlet box	Encapsulated	90–264 VAC	4000 VAC	6/12 watt	8
TMPS 10	1.5" × 1"	PCB	Encapsulated	85–264 VAC	3000 VAC	10 watt	9
TMPW 10	1.46" × 1.08"	PCB	Encapsulated	90–305 VAC	4000 VAC	10 watt	9
TMPW 10-J/-T	2.17" × 1.08"	Chassis	Encapsulated	90–305 VAC	4000 VAC	10 watt	10
TMPW 15	1.84" × 1.14"	PCB	Encapsulated	90–305 VAC	4000 VAC	NEW	15 watt 10
TMPW 15-J/-T	2.7" × 1.35"	Chassis	Encapsulated	90–305 VAC	4000 VAC	NEW	15 watt 11
TMPS 15	2" × 1"	PCB	Encapsulated	85–264 VAC	3000 VAC	15 watt	11
TPP 15-J	2.82" × 1.14"	Chassis	Encapsulated	85–264 VAC	4000 VAC	15 watt	12
TPP 15-D	1.65" × 1.14	PCB	Encapsulated	85–264 VAC	4000 VAC	15 watt	12
TPP 15A-J	2.6" × 1.0"	Chassis	Open frame	85–264 VAC	4000 VAC	15 watt	13
TPP 15A-D	1.5" × 1.0"	PCB	Open frame	85–264 VAC	4000 VAC	15 watt	13
TIW 24	2.2" × 2.2"	Outlet box	Encapsulated	90–264 VAC	4000 VAC	24 watt	14
TMW 24	2.09" × 2.0"	Outlet box	Encapsulated	85–264 VAC	4000 VAC	24 watt	14
TMW 24P	2.09" × 2.0"	Outlet box	Encapsulated	85–264 VAC	4000 VAC	24 watt	15
TMPW 25	2.07" × 1.08"	PCB	Encapsulated	90–305 VAC	4000 VAC	NEW models	25 watt 15
TMPW 25-J/-T	3.48" × 1.08"	Chassis	Encapsulated	90–305 VAC	4000 VAC	NEW models	25 watt 16
TPP 30-J	3.95" × 1.5"	Chassis	Encapsulated	85–264 VAC	4000 VAC	30 watt	16
TPP 30-D	2.89" × 1.50"	PCB	Encapsulated	85–264 VAC	4000 VAC	30 watt	17
TPP 30A-J	3.34" × 1.36"	Chassis	Open frame	85–264 VAC	4000 VAC	30 watt	17
TPP 30A-D	2.74" × 1.1"	PCB	Open frame	85–264 VAC	4000 VAC	30 watt	18
TMW 36	2.09" × 2.0"	Outlet box	Encapsulated	85–264 VAC	4000 VAC	36 watt	18
TMW 36P	09" × 2.0"	Outlet box	Encapsulated	85–264 VAC	4000 VAC	36 watt	19
TMPW 40	2.52" × 1.8"	PCB	Encapsulated	90–305 VAC	4000 VAC	NEW	40 watt 19
TMPW 40-J/-T	3.48" × 1.84"	Chassis	Encapsulated	90–305 VAC	4000 VAC	NEW	40 watt 20
TMPW 50	2.92" × 1.85"	PCB	Encapsulated	90–305 VAC	4000 VAC	50 watt	20
TMPW 50-J/-T	3.81" × 1.85"	Chassis	Encapsulated	90–305 VAC	4000 VAC	50 watt	21
TMPW 60	2.92" × 1.85"	PCB	Encapsulated	90–305 VAC	4000 VAC	NEW	60 watt 21
TMPW 60-J/-T	3.81" × 1.85"	Chassis	Encapsulated	90–305 VAC	4000 VAC	NEW	60 watt 22
TMPW 80	3.2" × 1.85"	PCB	Encapsulated	90–305 VAC	4000 VAC	NEW under development	80 watt 22
TMPW 80-J/-T	4.24" × 2.0"	Chassis	Encapsulated	90–305 VAC	4000 VAC	NEW under development	80 watt 23
TMPW 100	3.5" × 2.05"	PCB	Encapsulated	90–305 VAC	4000 VAC	NEW under development	100 watt 23
TMPW 100-J/-T	4.57" × 2.2"	Chassis	Encapsulated	90–305 VAC	4000 VAC	NEW under development	100 watt 24

Household & Building Automation AC/DC Power Supplies (DIN-Rail Mounting)

	Housing	Input	Key features & key certifications		
TBLC	Low profile (55 mm depth)	85–264 VAC	UL 1310, UL 508, EN 60335-1	6–90 watt	25
TBL	Low profile (55 mm depth)	85–264 VAC	UL 1310, UL 508, EN 60335-1	15–150 watt	26
TPC	Slim (reduced width)	85–264 VAC	ErP ready, UL 508	30–120 watt	26
TCL	Slim (reduced width)	85–264 VAC	UL 508	24–240 watt	27
TSPC-240-124UPS	Regular (114 mm depth)	85–264 VAC	Uninterruptable Power Supply (UPS)	240 watt	27

Accessories

	Housing	Key features		
TSP-BCMU360	Regular (113 mm depth)	Battery controller module for Uninterruptable Power Supply (UPS)	360 watt	28

PCB, Outlet box and Chassis Mountable

- Convection-cooled operation
- Up to 94% power conversion efficiency
- Ultra-low standby power (ErP compliant)
- Fully encapsulated and open-frame solutions available
- EN 60335-1 approved (household applications)
- IEC/EN/UL 62368-1 approved
- IEC /EN/ES 60601-1 3rd edition medical approved (2 × MOPP) available



TMPS 03 | 3 W

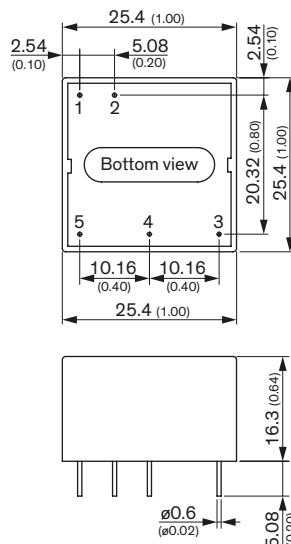

Model	Output Voltage nom.	Output Current max.	Output Current peak	Efficiency typ.
TMPS 03-103	3.3 VDC	900 mA	1170 mA	70%
TMPS 03-105	5 VDC	600 mA	780 mA	72%
TMPS 03-109	9 VDC	333 mA	430 mA	77%
TMPS 03-112	12 VDC	250 mA	320 mA	78%
TMPS 03-115	15 VDC	200 mA	260 mA	78%
TMPS 03-124	24 VDC	125 mA	160 mA	78%

- PCB Power module in 1" × 1" package
- No load input power <150 mW, to comply with ErP directive
- Operating temperature range -25°C to +70°C
- Certified to IEC/EN 60335-1 for household appliance
- EMI meets EN 55032, class B
- Protection class II prepared
- 3-year product warranty

Pin Connections	
Pin	Function
1	AC (N)
2	AC (L)
3	NC
4	-Vout
5	+Vout



TMPS 05 | 5 W

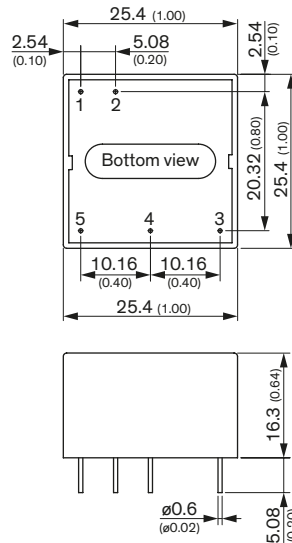

- PCB Power module in 1" × 1" package
- Certified to IEC/EN 60335-1 for household appliance
- No load input power <300 mW to comply with ErP directive
- Operating temperature range -25°C to +70°C
- EMI meets EN 55032 class B and EN 55014-1
- Protection class II prepared
- 3-year product warranty

Pin Connections

Pin	Function
1	AC (N)
2	AC (L)
3	NC*
4	-Vout
5	+Vout

* Internally not connected but keep it isolated from primary circuit

Model	Output Voltage nom.	Output Current max.	Output Current peak	Efficiency typ.
TMPS 05-103	3.3 VDC	1515 mA	1970 mA	74%
TMPS 05-105	5 VDC	1000 mA	1300 mA	80%
TMPS 05-109	9 VDC	555 mA	721 mA	82%
TMPS 05-112	12 VDC	416 mA	540 mA	82%
TMPS 05-115	15 VDC	333 mA	433 mA	83%
TMPS 05-124	24 VDC	208 mA	270 mA	83%
TMPS 05-148	48 VDC	104 mA	135 mA	85%

TMPW 5 | 5 W

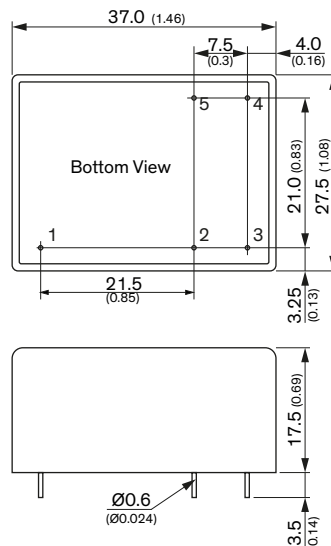

- Compact PCB power module in 1.46" × 1.08" package
- Wide input voltage range 90–305 VAC
- Certified according to EN 60335-1 and IEC/EN/UL 62368-1
- I/O-Isolation 4000 VAC
- Operating temperature range -40°C to +70°C
- No load input power <0.1 W (acc. ErP directive)
- High efficiency up to 83%
- Internal EN 55032 class B filter
- Protection class II prepared
- 3-year product warranty

Pin Connections

Pin	Single
1	NC
2	+Vout
3	-Vout
4	AC (L)
5	AC (N)

Model	Output Voltage nom.	Output Current max.	Efficiency typ.
TMPW 5-103	3.3 VDC	1515 mA	73%
TMPW 5-105	5 VDC	1000 mA	77%
TMPW 5-112	12 VDC	420 mA	81%
TMPW 5-124	24 VDC	210 mA	83%





TMPW 5-J/-T | 5 W

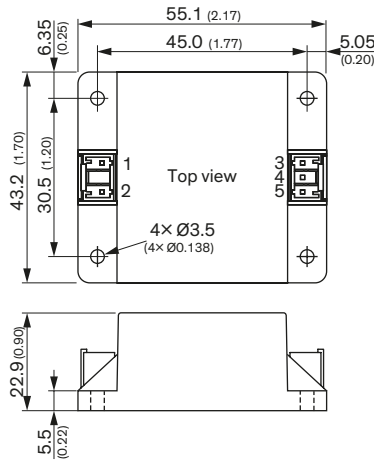

- Compact chassis mount power module in 2.17" x 1.70" package
- Wide input voltage range 90–305 VAC
- Certified according to EN 60335-1 and IEC/EN/UL 62368-1
- I/O-Isolation 4000 VAC
- Operating temperature range –40°C to +70°C
- No load input power <0.1 W (acc. ErP directive)
- High efficiency up to 83%
- Internal EN 55032 class B filter
- Protection class II prepared
- 3-year product warranty

Pin Connections	
Pin	Single
1	AC (L)
2	AC (N)
3	–Vout
4	NC
5	+Vout

Model	Output Voltage nom.	Output Current max.	Efficiency typ.
TMPW 5-103-J/-T*	3.3 VDC	1515 mA	73%
TMPW 5-105-J/-T*	5 VDC	1000 mA	77%
TMPW 5-112-J/-T*	12 VDC	420 mA	81%
TMPW 5-124-J/-T*	24 VDC	210 mA	83%

* -J = JST connector
 -T = Screw Terminal



TIW 6 / TIW 12 | 6/12 W

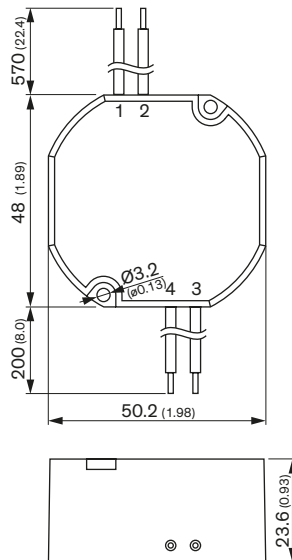

- High efficiency switching power supplies
- Easy installation into standard flush boxes
- Fully encapsulated plastic housing
- Dust and waterproof to IP 67
- Protection class II
- Safety approval to IEC/EN 62368-1, EN 50178, EN 60335-1, UL 1310 class 2
- Approved for mounting onto wood or materials with unknown flammability
- Ready to meet ErP directive
- Universal input range 90 to 264 VAC
- Operating temp. range –25°C to +50°C
- Short circuit and overload protection
- 3-year product warranty

Pinout			
Pin	Wire	Color	Type
1	AC (N)	White	18AWG/0.82 mm ²
2	AC (L)	Black	18AWG/0.82 mm ²
3	–Vout	Black	20AWG/0.52 mm ²
4	+Vout	Red	20AWG/0.52 mm ²

Model	Output Voltage	Output Current	Efficiency typ.
TIW 06-103	3.3 VDC	1.2 A	73%
TIW 06-105	5 VDC	1.0 A	75%
TIW 06-106	6 VDC	1.0 A	81%
TIW 12-112	12 VDC	1.0 A	79%
TIW 12-115	15 VDC	0.8 A	80%
TIW 12-124	24 VDC	0.5 A	81%



TMPS 10 | 10 W

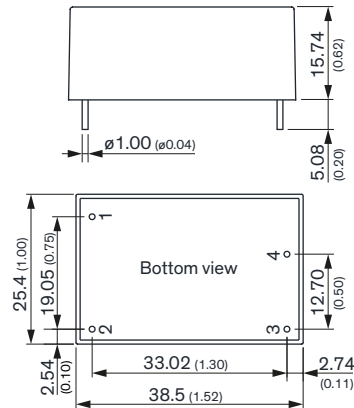

- Ultra Compact 10 Watt PCB Power module in 1" × 1.5" package
- Certified to IEC/EN 60335-1 and UL 62368-1 for household and industrial appliance
- Reinforced I/O isolation 4000 VAC
- Operating temperature range -25°C to +70°C
- Allows 130% peak current up to 30 s
- Ready to meet ErP directive, <0.15 W no load power consumption
- EMI meets EN 55032 class B and EN 55014-1
- Protection class II prepared
- 3-year product warranty

Pin Connections

Pin	Function
1	AC (N)
2	AC (L)
3	-Vout
4	+Vout

Model	Output Voltage nom.	Output Current max.	Output Current peak	Efficiency typ.
TMPS 10-103	3.3 VDC	2600 mA	3380 mA	77%
TMPS 10-105	5 VDC	2000 mA	2600 mA	80%
TMPS 10-109	9 VDC	1100 mA	1440 mA	83%
TMPS 10-112	12 VDC	830 mA	1080 mA	84%
TMPS 10-115	15 VDC	660 mA	860 mA	84%
TMPS 10-124	24 VDC	410 mA	530 mA	86%
TMPS 10-148	48 VDC	210 mA	270 mA	84%

TMPW 10 | 10 W

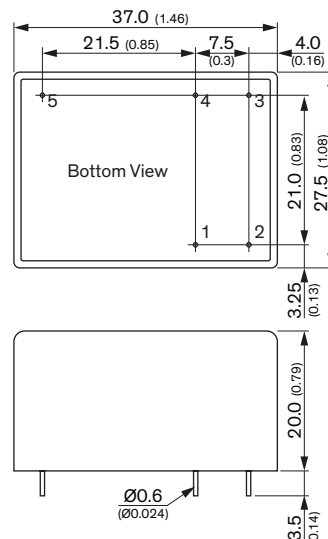

- Compact PCB power module in 1.46" × 1.08" package
- Wide input voltage range 90–305 VAC
- Certified according to EN 60335-1 and IEC/EN/UL 62368-1
- I/O-Isolation 4000 VAC
- Operating temperature range -40°C to +70°C
- No load input power <0.1 W (acc. ErP directive)
- High efficiency up to 86%
- Internal EN 55032 class B filter
- Protection class II prepared
- 3-year product warranty

Pin Connections

Pin	Single
1	+Vout
2	-Vout
3	AC IN (L)
4	AC IN (N)
5	NC

Model	Output Voltage nom.	Output Current max.	Efficiency typ.
TMPW 10-105	5 VDC	2000 mA	81%
TMPW 10-112	12 VDC	833 mA	85%
TMPW 10-115	15 VDC	667 mA	86%
TMPW 10-124	24 VDC	417 mA	86%

TMPW Series

TRACO POWER

New

TMPW Series

Compact 5-50 Watt AC/DC for industrial and household applications



TMPW 10-J/-T | 10 W

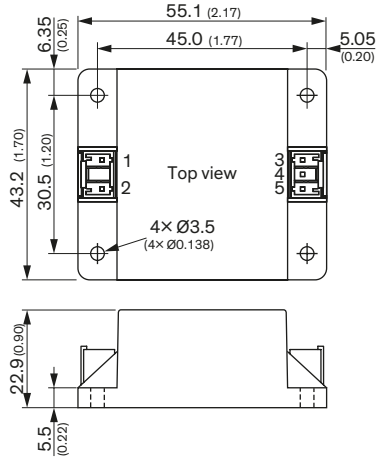

- Compact chassis mount power module in 2.17" x 1.70" package
- Wide input voltage range 90–305 VAC
- Certified according to EN 60335-1 and IEC/EN/UL 62368-1
- I/O-Isolation 4000 VAC
- Operating temperature range –40°C to +70°C
- No load input power <0.1 W (acc. ErP directive)
- High efficiency up to 86%
- Internal EN 55032 class B filter
- Protection class II prepared
- 3-year product warranty

Pin Connections	
Pin	Single
1	AC (L)
2	AC (N)
3	–Vout
4	NC
5	+Vout

Model	Output Voltage nom.	Output Current max.	Efficiency typ.
TMPW 10-105-J/-T*	5 VDC	2000 mA	81%
TMPW 10-112-J/-T*	12 VDC	833 mA	85%
TMPW 10-115-J/-T*	15 VDC	667 mA	86%
TMPW 10-124-J/-T*	24 VDC	417 mA	86%

* -J = JST connector
-T = Screw Terminal



TMPW 15 | 15 W

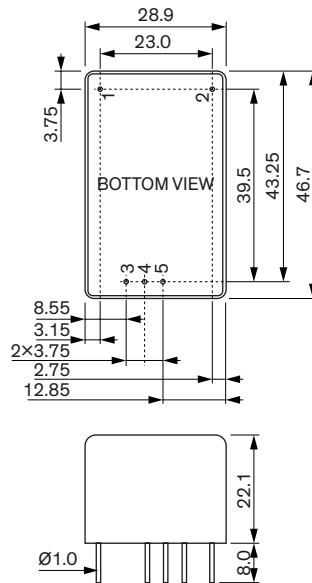

- Compact PCB power module in 1.84" x 1.14" package
- Wide input voltage range 90 – 305 VAC
- Certified according to EN 60335-1 and IEC/EN/UL 62368-1
- I/O-Isolation 4000 VAC
- Operating temperature range –40°C to +70°C
- No load input power <0.1 W (acc. ErP directive)
- High efficiency up to 83%
- Internal EN 55032 class B filter
- Protection class II prepared
- 3 year product warranty

Pinout		
Pin	Single	Dual
1		AC (N)
2		AC (L)
3		–Vout
4	No Pin	Common
5		+Vout

Model	Output Voltage nom.	Output Current max.	Efficiency typ.
TMPW 15-105	5 VDC	3000 mA	81%
TMPW 15-112	12 VDC	1250 mA	85%
TMPW 15-115	15 VDC	1000 mA	85%
TMPW 15-124	24 VDC	625 mA	86%
TMPW 15-148	48 VDC	312.5 mA	87%
TMPW 15-212	±12 VDC	±625 mA	84%
TMPW 15-215	±15 VDC	±500 mA	84%



TMPW 15-J/-T | 15 W

NEW!

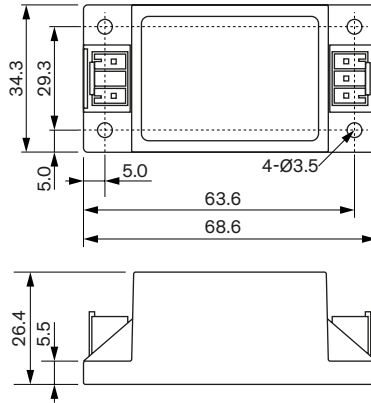

- Compact Chassis mount power module in 2.7" × 1.35" package
- Wide input voltage range 90–305 VAC
- Certified according to EN 60335-1 and IEC/EN/UL 62368-1
- I/O-Isolation 4000 VAC
- Operating temperature range –40°C to +70°C
- No load input power <0.1 W (acc. ErP directive)
- High efficiency up to 83%
- Internal EN 55032 class B filter
- Protection class II prepared
- 3 year product warranty

Pinout		
Pin	Single	Dual
1		AC (L)
2		AC (N)
3		+Vout
4	NC	Common
5		-Vout

Model	Output Voltage nom.	Output Current max.	Efficiency typ.
TMPW 15-105-J/-T*	5 VDC	3000 mA	81%
TMPW 15-112-J/-T*	12 VDC	1250 mA	85%
TMPW 15-115-J/-T*	15 VDC	1000 mA	85%
TMPW 15-124-J/-T*	24 VDC	625 mA	86%
TMPW 15-148-J/-T*	48 VDC	312.5 mA	87%
TMPW 15-212-J/-T*	±12 VDC	±625 mA	84%
TMPW 15-215-J/-T*	±15 VDC	±500 mA	84%

* -J = JST connector
 -T = Screw Terminal

- J Input/Output: B03B-PSILE-A1
 mates w/ crimp terminal: SPSI-41T-M1.1 or SPS1-001T-M1.1
 and terminal housing: PSIP-03V-LE-A
 - T Input/Output: EK381V-03P

TMPS 15 | 15 W

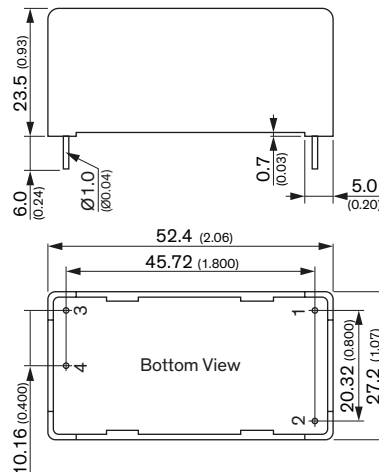

- Fully encapsulated 1.07" × 2.06" × 0.93" package
- ErP-ready (<100 mW no-load power)
- EN 60335 certified (household)
- UL 62368-1 certified (IT and industrial)
- –25°C up to +70°C operating temperature
- 130% peak power (for up to 30 s)
- Integrated class B EMI filter
- 3000 VAC I/O isolation (reinforced)
- Protection class II prepared
- 3-year product warranty

Pin Connections	
Pin	Function
1	AC (N)
2	AC (L)
3	+Vout
4	-Vout

Model	Output Voltage nom.	Output Current max.	Output Current peak	Efficiency typ.
TMPS 15-105	5 VDC	3000 mA	3900 mA	79%
TMPS 15-112	12 VDC	1250 mA	1625 mA	82%
TMPS 15-115	15 VDC	1000 mA	1300 mA	82%
TMPS 15-124	24 VDC	625 mA	813 mA	84%
TMPS 15-148	48 VDC	313 mA	407 mA	82%



TPP 15-J | 15 W CE UK CA ErP ready cRU US CB Scheme EAC

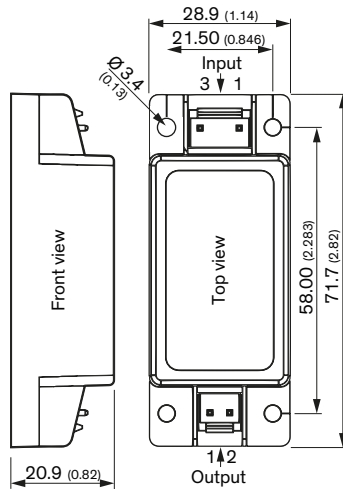

- High power density power supply (encapsulated)
- Certification according to IEC/EN/ES 60601-1 3rd edition for 2 × MOPP
- Low leakage current <100 µA rated for BF applications
- EMC compliance to IEC 60601-1-2 4th edition
- Risk management process according to ISO 14971 incl. risk management file
- Acceptance criteria for electronic assemblies acc. to IPC-A-610 Level 3
- Protection class II
- Operating up to 5000 m altitude
- Ready to meet ErP directive, no load power consumption <100 mW
- 5-year product warranty

Model	Output Voltage nom.	Output Current max.	Efficiency typ.
TPP 15-103-J	3.3 VDC	4000 mA	84%
TPP 15-105-J	5 VDC	3000 mA	86%
TPP 15-109-J	9 VDC	1670 mA	86%
TPP 15-112-J	12 VDC	1250 mA	87%
TPP 15-115-J	15 VDC	1000 mA	87%
TPP 15-124-J	24 VDC	625 mA	88%
TPP 15-136-J	36 VDC	417 mA	88%
TPP 15-148-J	48 VDC	313 mA	89%

Pin Connectors			
Input		Output	
Pin	Function	Pin	Function
1	AC (L)	1	-Vout
3	AC (N/I)	2	+Vout

TPP 15-D | 15 W CE UK CA ErP ready cRU US CB Scheme EAC

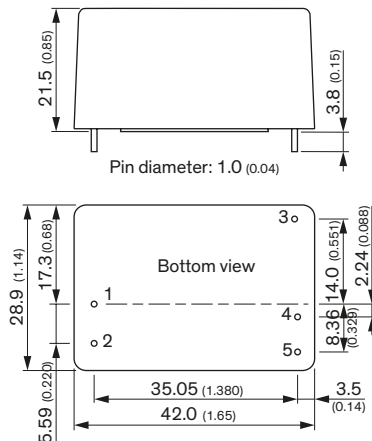

- High power density power supply (encapsulated)
- Certification according to IEC/EN/ES 60601-1 3rd edition for 2 × MOPP
- Low leakage current <100 µA rated for BF applications
- EMC compliance to IEC 60601-1-2 4th edition
- Risk management process according to ISO 14971 incl. risk management file
- Acceptance criteria for electronic assemblies acc. to IPC-A-610 Level 3
- Protection class II
- Operating up to 5000 m altitude
- Ready to meet ErP directive, no load power consumption <100 mW
- 5-year product warranty

Model	Output Voltage nom. *	*adjustable	Output Current max.	Efficiency typ.
TPP 15-103-D	3.3 VDC	2.97–3.63 VDC	4000 mA	84%
TPP 15-105-D	5 VDC	4.5–5.5 VDC	3000 mA	86%
TPP 15-109-D	9 VDC	8.1–9.9 VDC	1670 mA	86%
TPP 15-112-D	12 VDC	10.8–13.2 VDC	1250 mA	87%
TPP 15-115-D	15 VDC	13.5–16.5 VDC	1000 mA	87%
TPP 15-124-D	24 VDC	21.6–26.4 VDC	625 mA	88%
TPP 15-136-D	36 VDC	32.4–39.6 VDC	417 mA	88%
TPP 15-148-D	48 VDC	43.2–52.8 VDC	313 mA	89%

Pin Connections	
Pin	Function
1	AC (N)
2	AC (L)
3	Trim
4	-Vout
5	+Vout



TPP 15A-J | 15 W



12, 15, 24, 36 and 48 VDC models – without heatsink

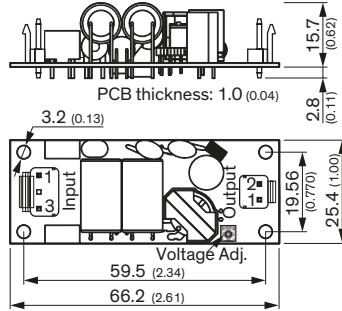

3.3, 5 and 9 VDC models – with heatsink

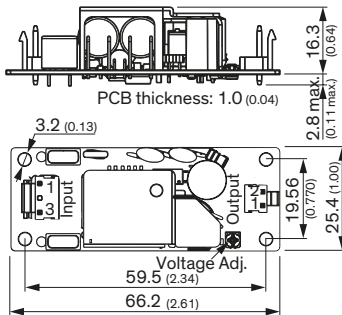

Pin Connectors

Input		Output	
Pin	Function	Pin	Function
1	AC (L)	1	-Vout
3	AC (N)	2	+Vout

- High power density power supply (open frame)
- Certification according to IEC/EN/ES 60601-1 3rd edition for 2 × MOPP
- Low leakage current <100 µA rated for BF applications
- EMC compliance to IEC 60601-1-2 4th edition
- Risk management process according to ISO 14971 incl. risk management file
- Acceptance criteria for electronic assemblies acc. to IPC-A-610 Level 3
- Protection class I and II
- Operating up to 5000 m altitude
- Ready to meet ErP directive, no load power consumption <100 mW
- 5-year product warranty

Model	Output Voltage nom. (adjustable)	Output Current max.	Efficiency typ.
TPP 15-103A-J	3.3 VDC (2.97–3.63 VDC)	4000 mA	84%
TPP 15-105A-J	5 VDC (4.5–5.5 VDC)	3000 mA	86%
TPP 15-109A-J	9 VDC (8.1–9.9 VDC)	1670 mA	86%
TPP 15-112A-J	12 VDC (10.8–13.2 VDC)	1250 mA	87%
TPP 15-115A-J	15 VDC (13.5–16.5 VDC)	1000 mA	87%
TPP 15-124A-J	24 VDC (21.6–26.4 VDC)	625 mA	88%
TPP 15-136A-J	36 VDC (32.4–39.6 VDC)	417 mA	88%
TPP 15-148A-J	48 VDC (43.2–52.8 VDC)	313 mA	89%

TPP 15A-D | 15 W



12, 15, 24, 36 and 48 VDC models – without heatsink

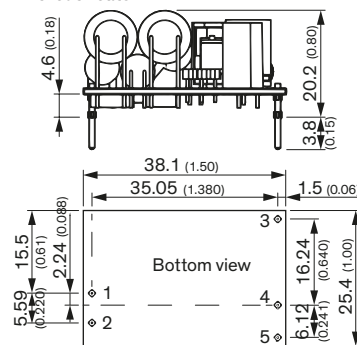

3.3, 5 and 9 VDC models –with heatsink

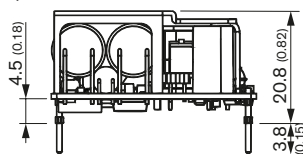

Pinout

Pin	Function
1	AC (N)
2	AC (L)
3	Trim
4	-Vout
5	+Vout

- High power density power supply (open frame)
- Certification according to IEC/EN/ES 60601-1 3rd edition for 2 × MOPP
- Low leakage current <100 µA rated for BF applications
- EMC compliance to IEC 60601-1-2 4th edition
- Risk management process according to ISO 14971 incl. risk management file
- Acceptance criteria for electronic assemblies acc. to IPC-A-610 Level 3
- Protection class II
- Operating up to 5000 m altitude
- Ready to meet ErP directive, no load power consumption <100 mW
- 5-year product warranty

Model	Output Voltage nom. (adjustable)	Output Current max.	Efficiency typ.
TPP 15-103A-D	3.3 VDC (2.97–3.63 VDC)	4000 mA	84%
TPP 15-105A-D	5 VDC (4.5–5.5 VDC)	3000 mA	86%
TPP 15-109A-D	9 VDC (8.1–9.9 VDC)	1670 mA	86%
TPP 15-112A-D	12 VDC (10.8–13.2 VDC)	1250 mA	87%
TPP 15-115A-D	15 VDC (13.5–16.5 VDC)	1000 mA	87%
TPP 15-124A-D	24 VDC (21.6–26.4 VDC)	625 mA	88%
TPP 15-136A-D	36 VDC (32.4–39.6 VDC)	417 mA	88%
TPP 15-148A-D	48 VDC (43.2–52.8 VDC)	313 mA	89%



TIW 24 | 24 W



- High efficiency switching power supplies
- Easy installation into standard flush boxes
- Fully encapsulated plastic housing
- Dust and waterproof to IP 67
- Protection class II
- Safety approval to IEC/EN 62368-1, EN 50178, EN 60335-1, UL 1310 class 2
- Approved for mounting onto wood or materials with unknown flammability
- Ready to meet ErP directive
- Universal input range 90 to 264 VAC
- Operating temp. range -25°C to +50°C
- Short circuit and overload protection
- 3-year product warranty

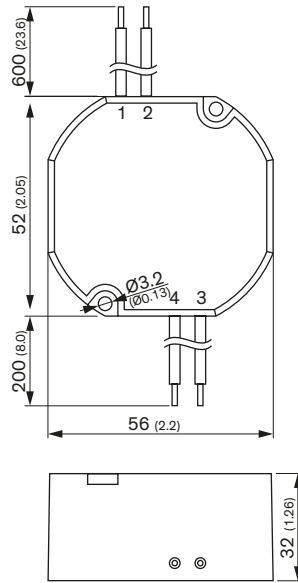

Pinout			
Pin	Wire	Color	Type
1	Vac IN (N)	White	18AWG/0.82 mm ²
2	Vac IN (L)	Black	18AWG/0.82 mm ²
3	-Vout	Black	20AWG/0.52mm ²
4	+Vout	Red	20AWG/0.52mm ²

Model	Output Voltage	Output Current	Efficiency typ.
TIW 24-112	12 VDC	2.0 A	83%
TIW 24-124	24 VDC	1.0 A	85%

TMW 24 | 24 W



- Fully encapsulated, dust resistant, and waterproof (IP68 certified)
- Operating temperature range -20°C to +80°C
- Mountable in wall outlet boxes
- Screw mountable on wood and inside furniture
- Safety approval IEC/EN 62368-1 and IEC/EN 60335-1
- IEC/EN 60601-1 (3rd edition) certified, 2 x MOPP compliant
- Leakage current <100 µA for body-floating (BF) applications
- I/O isolation 4000 VAC (reinforced)
- Short-circuit protection (SCP), overvoltage protection (OVP) and overtemperature protection (OTP)
- 5 year product warranty

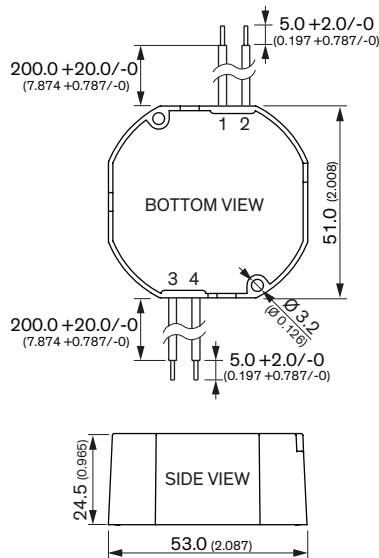

Pinout			
Pin	Wire	Color	Type
1	Vac IN (N)	Blue	20AWG/0.52 mm ²
2	Vac IN (L)	Brown	20AWG/0.52 mm ²
3	-Vout	Black	20AWG/0.52 mm ²
4	+Vout	Red	20AWG/0.52 mm ²

Model *	Output Voltage nom.	Output Current max.	Efficiency typ.
TMW 24-105	5.1 VDC	4000 mA	85%
TMW 24-112	12 VDC	2000 mA	88%
TMW 24-124	24 VDC	1000 mA	89%

* Also available as pin version: suffix -P

TMW Series TRACO POWER

New
TMW Series

AC/DC Power Supply

Fully encapsulated, dust resistant, and waterproof

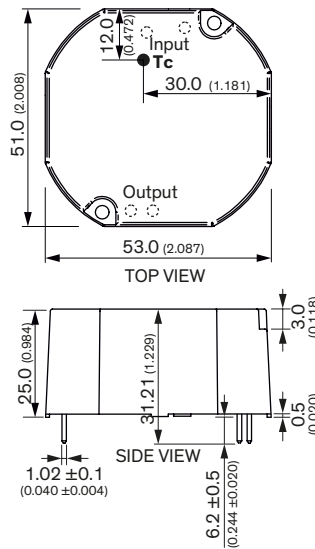
**TMW 24P | 24 W**

- Fully encapsulated, dust resistant, and waterproof (IP68 certified)
- Operating temperature range -20°C to +80°C
- Mountable in wall outlet boxes
- Screw mountable on wood and inside furniture
- Safety approval IEC/EN 62368-1 and IEC/EN 60335-1
- IEC/EN 60601-1 (3rd edition) certified, 2 x MOPP compliant
- Leakage current < 100 µA for body-floating (BF) applications
- I/O isolation 4000 VAC (reinforced)
- Short-circuit protection (SCP), overvoltage protection (OVP) and overtemperature protection (OTP)
- 5 year product warranty

Pinout	
Pin	Function
1	AC (N)
2	AC (L)
3	-Vout
4	+Vout

Model	Output Voltage nom.	Output Current max.	Efficiency typ.
TMW 24-105P	5.1 VDC	4000 mA	85%
TMW 24-112P	12 VDC	2000 mA	88%
TMW 24-124P	24 VDC	1000 mA	90%

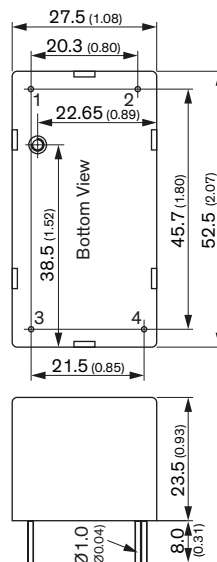
**TMPW 25 | 25 W****NEW MODELS**

- Compact PCB power module in 2.07" x 1.08" package
- Wide input voltage range 90-305 VAC
- Certified according to EN 60335-1 and IEC/EN/UL 62368-1
- I/O-Isolation 4000 VAC
- Operating temperature range -40°C to +70°C
- No load input power < 0.1 W (acc. ErP directive)
- High efficiency up to 88%
- Internal EN 55032 class B filter
- Protection class II prepared
- 3-year product warranty

Pin Connections	
Pin	Function
1	AC (L)
2	AC (N)
3	+Vout
4	-Vout

Model	Output Voltage nom.	Output Current max.	Efficiency typ.
TMPW 25-105	5.1 VDC	3922 mA	84%
TMPW 25-112	12 VDC	2083 mA	88%
TMPW 25-115	15 VDC	1666 mA	88%
TMPW 25-124	24 VDC	1042 mA	87%
TMPW 25-212	±12 VDC	±1042 mA	87%
TMPW 25-215	±15 VDC	±833 mA	87%





TMPW 25-J/-T | 25 W

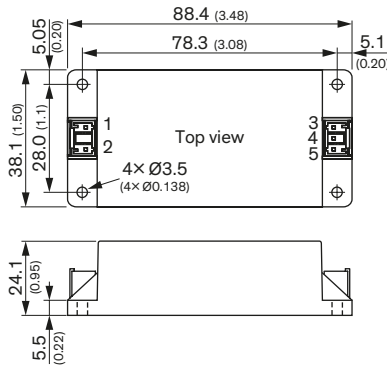

- Compact chassis mount power module in 3.48" x 1.50" package
- Wide input voltage range 90–305 VAC
- Certified according to EN 60335-1 and IEC/EN/UL 62368-1
- I/O-Isolation 4000 VAC
- Operating temperature range –40°C to +70°C
- No load input power <0.1 W (acc. ErP directive)
- High efficiency up to 88%
- Internal EN 55032 class B filter
- Protection class II prepared
- 3-year product warranty

Pin Connections	
Pin	Single
1	AC IN (N)
2	AC IN (L)
3	–Vout
4	NC
5	+Vout

Model	Output Voltage nom.	Output Current max.	Efficiency typ.
TMPW 25-105-J/-T*	5.1 VDC	3922 mA	84%
TMPW 25-112-J/-T*	12 VDC	2083 mA	88%
TMPW 25-115-J/-T*	15 VDC	1666 mA	88%
TMPW 25-124-J/-T*	24 VDC	1042 mA	87%
TMPW 25-212-J/-T*	±12 VDC	±1042 mA	87%
TMPW 25-215-J/-T*	±15 VDC	±833 mA	87%

* -J = JST connector
-T = Screw Terminal



TPP 30-J | 30 W

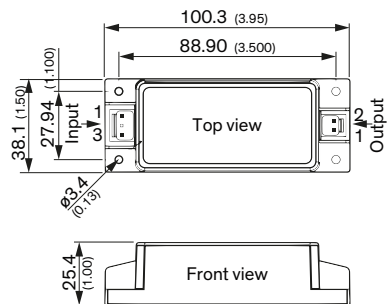

- High power density power supply (encapsulated)
- Certification according to IEC/EN/ES 60601-1 3rd edition for 2 x MOPP
- Low leakage current <75 µA rated for BF applications
- EMC compliance to IEC 60601-1-2 4th edition
- Risk management process according to ISO 14971 incl. risk management file
- Acceptance criteria for electronic assemblies acc. to IPC-A-610 Level 3
- Protection class II
- Operating up to 5000 m altitude
- Ready to meet ErP directive, no load power consumption <60 mW
- 5-year product warranty

Pin Connectors			
Input		Output	
Pin	Function	Pin	Function
1	AC (L)	1	+Vout
3	AC (N)	2	–Vout

Model	Output Voltage nom.	Output Current max.	Efficiency typ.
TPP 30-103-J	3.3 VDC (2.97–3.63 VDC)	6000 mA	84%
TPP 30-105-J	5 VDC (4.5–5.5 VDC)	6000 mA	87%
TPP 30-109-J	9 VDC (8.1–9.9 VDC)	3340 mA	88%
TPP 30-112-J	12 VDC (10.8–13.2 VDC)	2500 mA	91%
TPP 30-115-J	15 VDC (13.5–16.5 VDC)	2000 mA	91%
TPP 30-124-J	24 VDC (21.6–26.4 VDC)	1250 mA	90%
TPP 30-136-J	36 VDC (32.4–39.6 VDC)	840 mA	90%
TPP 30-148-J	48 VDC (43.2–52.8 VDC)	630 mA	92%



TPP 30-D | 30 W



- High power density power supply (encapsulated)
- Certification according to IEC/EN/ES 60601-1 3rd edition for 2 × MOPP
- Low leakage current <75 µA rated for BF applications
- EMC compliance to IEC 60601-1-2 4th edition
- Risk management process according to ISO 14971 incl. risk management file
- Acceptance criteria for electronic assemblies acc. to IPC-A-610 Level 3
- Protection class II
- Operating up to 5000 m altitude
- Ready to meet ErP directive, no load power consumption <60 mW
- 5-year product warranty

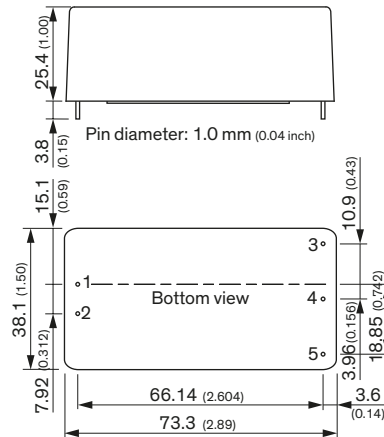

Pinout	
Pin	Function
1	AC (N)
2	AC (L)
3	+Vout
4	-Vout
5	Trim

Model	Output Voltage nom. (adjustable)	Output Current max.	Efficiency typ.
TPP 30-103-D	3.3 VDC (2.97–3.63 VDC)	6000 mA	84%
TPP 30-105-D	5 VDC (4.5–5.5 VDC)	6000 mA	87%
TPP 30-109-D	9 VDC (8.1–9.9 VDC)	3340 mA	88%
TPP 30-112-D	12 VDC (10.8–13.2 VDC)	2500 mA	91%
TPP 30-115-D	15 VDC (13.5–16.5 VDC)	2000 mA	91%
TPP 30-124-D	24 VDC (21.6–26.4 VDC)	1250 mA	90%
TPP 30-136-D	36 VDC (32.4–39.6 VDC)	840 mA	90%
TPP 30-148-D	48 VDC (43.2–52.8 VDC)	630 mA	92%

TPP 30A-J | 30 W



- High power density power supply (open frame)
- Certification according to IEC/EN/ES 60601-1 3rd edition for 2 × MOPP
- Low leakage current <75 µA rated for BF applications
- EMC compliance to IEC 60601-1-2 4th edition
- Risk management process according to ISO 14971 incl. risk management file
- Acceptance criteria for electronic assemblies acc. to IPC-A-610 Level 3
- Protection class I and II
- Operating up to 5000 m altitude
- Ready to meet ErP directive, no load power consumption <60 mW
- 5-year product warranty

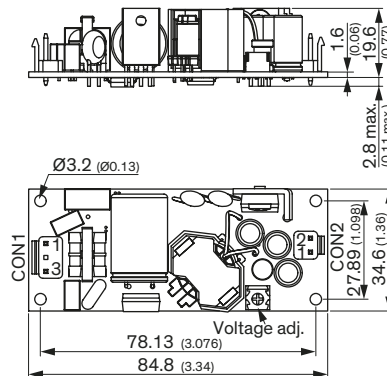

Pin Connectors			
Input (CON1)		Output (CON2)	
Pin	Function	Pin	Function
1	AC (L)	1	+Vout
3	AC (N)	2	-Vout

Model	Output Voltage nom. (adjustable)	Output Current max.	Efficiency typ.
TPP 30-103A-J	3.3 VDC (2.97–3.63 VDC)	6000 mA	84%
TPP 30-105A-J	5 VDC (4.5–5.5 VDC)	6000 mA	87%
TPP 30-109A-J	9 VDC (8.1–9.9 VDC)	3340 mA	88%
TPP 30-112A-J	12 VDC (10.8–13.2 VDC)	2500 mA	91%
TPP 30-115A-J	15 VDC (13.5–16.5 VDC)	2000 mA	91%
TPP 30-124A-J	24 VDC (21.6–26.4 VDC)	1250 mA	90%
TPP 30-136A-J	36 VDC (32.4–39.6 VDC)	840 mA	90%
TPP 30-148A-J	48 VDC (43.2–52.8 VDC)	630 mA	92%



TPP 30A-D | 30 W

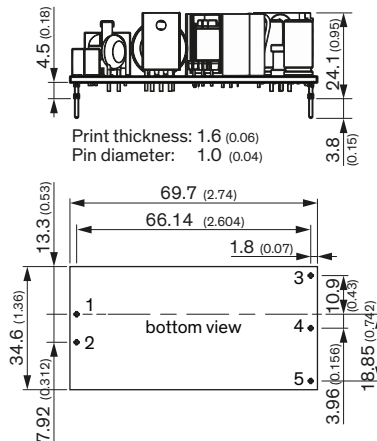

- High power density power supply (open frame)
- Certification according to IEC/EN/ES 60601-1 3rd edition for 2 × MOPP
- Low leakage current <75 µA rated for BF applications
- EMC compliance to IEC 60601-1-2 4th edition
- Risk management process according to ISO 14971 incl. risk management file
- Acceptance criteria for electronic assemblies acc. to IPC-A-610 Level 3
- Protection class II
- Operating up to 5000 m altitude
- Ready to meet ErP directive, no load power consumption <60 mW
- 5-year product warranty

Model	Output Voltage nom. (adjustable)	Output Current max.	Efficiency typ.
TPP 30-103A-D	3.3 VDC (2.97–3.63 VDC)	6000 mA	84%
TPP 30-105A-D	5 VDC (4.5–5.5 VDC)	6000 mA	87%
TPP 30-109A-D	9 VDC (8.1–9.9 VDC)	3340 mA	88%
TPP 30-112A-D	12 VDC (10.8–13.2 VDC)	2500 mA	91%
TPP 30-115A-D	15 VDC (13.5–16.5 VDC)	2000 mA	91%
TPP 30-124A-D	24 VDC (21.6–26.4 VDC)	1250 mA	90%
TPP 30-136A-D	36 VDC (32.4–39.6 VDC)	840 mA	90%
TPP 30-148A-D	48 VDC (43.2–52.8 VDC)	630 mA	92%

Pinout	
Pin	Function
1	AC (N)
2	AC (L)
3	+Vout
4	-Vout
5	Trim

TMW 36 | 36 W

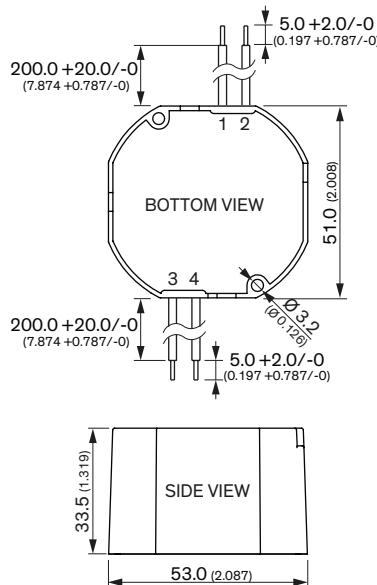

- Fully encapsulated, dust resistant, and waterproof (IP68 certified)
- Operating temperature range -20°C to +80°C
- Mountable in wall outlet boxes
- Screw mountable on wood and inside furniture
- Safety approval IEC/EN 62368-1 and IEC/EN 60335-1
- IEC/EN 60601-1 (3rd edition) certified, 2 × MOPP compliant
- Leakage current <100 µA for body-floating (BF) applications
- I/O isolation 4000 VAC (reinforced)
- Short-circuit protection (SCP), overvoltage protection (OVP) and overtemperature protection (OTP)
- 5 year product warranty

Model *	Output Voltage nom.	Output Current max.	Efficiency typ.
TMW 36-112	12 VDC	3.0 A	87%
TMW 36-124	24 VDC	1.5 A	87%

* Also available as pin version: suffix -P

Pinout			
Pin	Wire	Color	Type
1	Vac IN (N)	Blue	20AWG/0.52mm ²
2	Vac IN (L)	Brown	20AWG/0.52mm ²
3	-Vout	Black	20AWG/0.52mm ²
4	+Vout	Red	20AWG/0.52mm ²

TMW Series TRACCO POWER

New
TMW Series
AC/DC Power Supply
Fully encapsulated, dust resistant, and waterproof

**TMW 36P | 36 W**

- Fully encapsulated, dust resistant, and waterproof (IP68 certified)
- Operating temperature range -20°C to +80°C
- Mountable in wall outlet boxes
- Screw mountable on wood and inside furniture
- Safety approval IEC/EN 62368-1 and IEC/EN 60335-1
- IEC/EN 60601-1 (3rd edition) certified, 2 x MOPP compliant
- Leakage current <100 µA for body-floating (BF) applications
- I/O isolation 4000 VAC (reinforced)
- Short-circuit protection (SCP), overvoltage protection (OVP) and overtemperature protection (OTP)
- 5 year product warranty

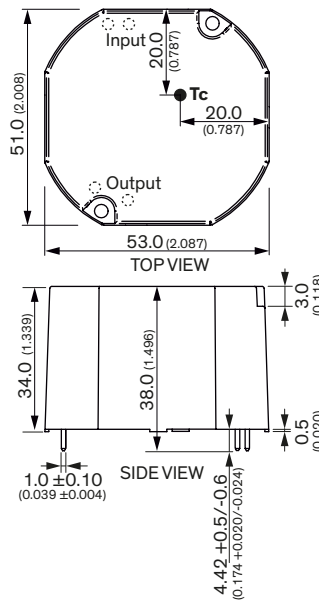

Pinout / Conecction	
Pin	Function
1	AC (N)
2	AC (L)
3	-Vout
4	+Vout

Model	Output Voltage nom.	Output Current max.	Efficiency typ.
TMW 36-112P	12 VDC	3.0 A	87%
TMW 36-124P	24 VDC	1.5 A	88%

**TMPW 40 | 40 W****NEW!**

- Compact PCB power module in 2.52" x 1.8" package
- Wide input voltage range 90-305 VAC
- Certified according to EN 60335-1 and IEC/EN/UL 62368-1
- I/O-Isolation 4000 VAC
- Operating temperature range -40°C to +70°C
- No load input power <0.1 W (acc. ErP directive)
- High efficiency up to 83%
- Internal EN 55032 class B filter
- Protection class II prepared
- 3 year product warranty

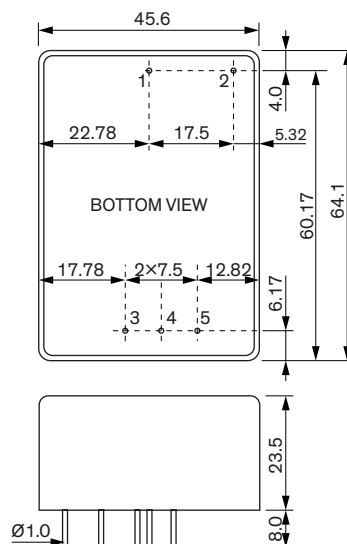

Pinout	
Pin	Single
1	AC IN (N)
2	AC IN (L)
3	-Vout
4	+Vout

Model	Output Voltage nom.	Output Current max.	Efficiency typ.
TMPW 40-105	5 VDC	7000 mA	87%
TMPW 40-112	12 VDC	3333 mA	90%
TMPW 40-115	15 VDC	2666 mA	90%
TMPW 40-124	24 VDC	1666 mA	89%
TMPW 40-148	48 VDC	833 mA	89%
TMPW 40-212	±12 VDC	±1666 mA	88%
TMPW 40-215	±15 VDC	±1333 mA	88%



TMPW 40-J/-T | 40 W

NEW!

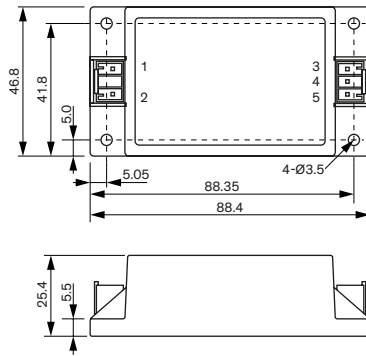

- Compact Chassis mount power module in 3.48" x 1.84" package
- Wide input voltage range 90–305 VAC
- Certified according to EN 60335-1 and IEC/EN/UL 62368-1
- I/O-Isolation 4000 VAC
- Operating temperature range –40°C to +70°C
- No load input power <0.1 W (acc. ErP directive)
- High efficiency up to 83%
- Internal EN 55032 class B filter
- Protection class II prepared
- 3 year product warranty

Pinout		
Pin	Single	Dual
1		AC (N)
2		AC (L)
3		–Vout
4	NC	Common
5		+Vout

Model	Output Voltage nom.	Output Current max.	Efficiency typ.
TMPW 40-105-J/-T*	5 VDC	7000 mA	87%
TMPW 40-112-J/-T*	12 VDC	3333 mA	90%
TMPW 40-115-J/-T*	15 VDC	2666 mA	90%
TMPW 40-124-J/-T*	24 VDC	1666 mA	89%
TMPW 40-148-J/-T*	48 VDC	833 mA	89%
TMPW 40-212-J/-T*	±12 VDC	±1666 mA	88%
TMPW 40-215-J/-T*	±15 VDC	±1333 mA	88%

* -J = JST connector
 -T = Screw Terminal

- J Input/Output: B03B-PSILE-A1 mates w/ crimp terminal: SPSI-41T-M1.1 or SPS1-001T-M1.1 and terminal housing: PSIP-03V-LE-A
 - T Input/Output: EK381V-03P

TMPW 50 | 50 W

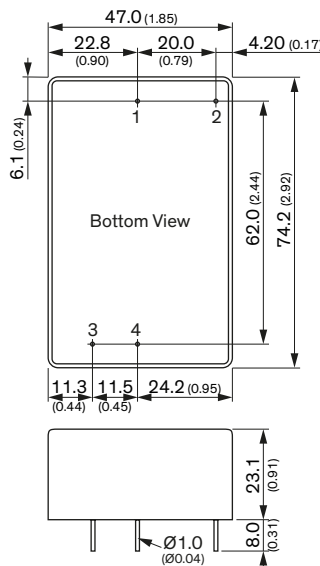

- Compact PCB power module in 2.92" x 1.85" package
- Wide input voltage range 90–305 VAC
- Certified according to EN 60335-1 and IEC/EN/UL 62368-1
- I/O-Isolation 4000 VAC
- Operating temperature range –40°C to +70°C
- No load input power <0.1 W (acc. ErP directive)
- High efficiency up to 89%
- Internal EN 55032 class B filter
- Protection class II prepared
- 3-year product warranty

Pin Connections	
Pin	Single
1	AC (N)
2	AC (L)
3	–Vout
4	+Vout

Model	Output Voltage nom.	Output Current max.	Efficiency typ.
TMPW 50-112	12 VDC	4167 mA	89%
TMPW 50-115	15 VDC	3333 mA	88%
TMPW 50-124	24 VDC	2083 mA	88%

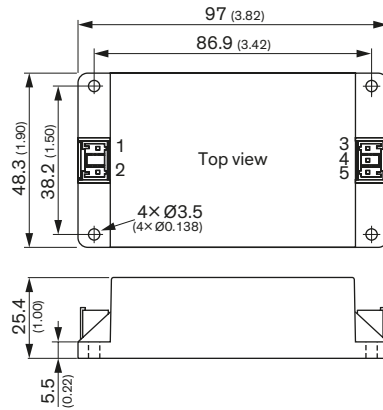
**TMPW 50-J/-T | 50 W**

- Compact chassis mount power module in 3.82" × 1.90" package
- Wide input voltage range 90–305 VAC
- Certified according to EN 60335-1 and IEC/EN/UL 62368-1
- I/O-Isolation 4000 VAC
- Operating temperature range –40°C to +70°C
- No load input power <0.1 W (acc. ErP directive)
- High efficiency up to 89%
- Internal EN 55032 class B filter
- Protection class II prepared
- 3-year product warranty

Pin Connections		
Pin	Single	
1	AC (N)	
2	AC (L)	
3	–Vout	
4	NC	
5	+Vout	

Model	Output Voltage nom.	Output Current max.	Efficiency typ.
TMPW 50-112-J/-T*	12 VDC	4167 mA	89%
TMPW 50-115-J/-T*	15 VDC	3333 mA	88%
TMPW 50-124-J/-T*	24 VDC	2083 mA	88%

* -J = JST connector
-T = Screw Terminal

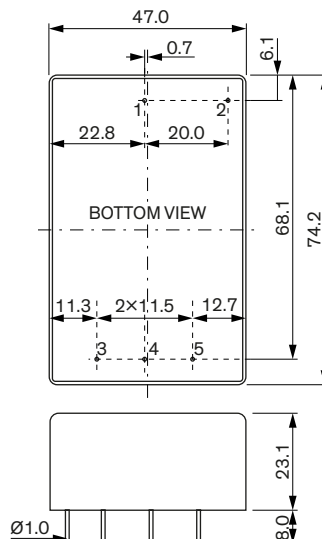
**TMPW 60 | 60 W****NEW!**

- Compact PCB power module in 2.92" × 1.85" package
- Wide input voltage range 90–305 VAC
- Certified according to EN 60335-1 and IEC/EN/UL 62368-1
- I/O-Isolation 4000 VAC
- Operating temperature range –40°C to +70°C
- No load input power <0.1 W (acc. ErP directive)
- High efficiency up to 89%
- Internal EN 55032 class B filter
- Protection class II prepared
- 3-year product warranty

Pinout		
Pin	Single	Dual
1	AC (N)	
2	AC (L)	
3	–Vout	
4	+Vout	Common
5	No Pin	+Vout

Model	Output Voltage nom.	Output Current max.	Efficiency typ.
TMPW 60-112	12 VDC	5000 mA	90%
TMPW 60-115	15 VDC	4000 mA	90%
TMPW 60-124	24 VDC	2500 mA	89%
TMPW 60-148	48 VDC	1250 mA	89%
TMPW 60-212	±12 VDC	±2500 mA	89%
TMPW 60-215	±15 VDC	±2000 mA	89%



TMPW 60-J/-T | 60 W

NEW!

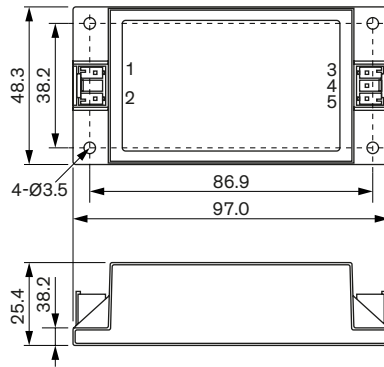

- Compact chassis mount power module in 3.82" x 1.90" package
- Wide input voltage range 90–305 VAC
- Certified according to EN 60335-1 and IEC/EN/UL 62368-1
- I/O-Isolation 4000 VAC
- Operating temperature range –40°C to +70°C
- No load input power <0.1 W (acc. ErP directive)
- High efficiency up to 88%
- Internal EN 55032 class B filter
- Protection class II prepared
- 3-year product warranty

Model	Output Voltage nom.	Output Current max.	Efficiency typ.
TMPW 60-112-J/-T*	12 VDC	5000 mA	90%
TMPW 60-115-J/-T*	15 VDC	4000 mA	90%
TMPW 60-124-J/-T*	24 VDC	2500 mA	89%
TMPW 60-148-J/-T*	48 VDC	1250 mA	89%
TMPW 60-212-J/-T*	±12 VDC	±2500 mA	89%
TMPW 60-215-J/-T*	±15 VDC	±2000 mA	89%

* -J = JST connector
-T = Screw Terminal

Pinout		
Pin	Single	Dual
1		AC (N)
2		AC (L)
3		–Vout
4	NC	Common
5		+Vout

TMPW 80 | 80 W

NEW
under development

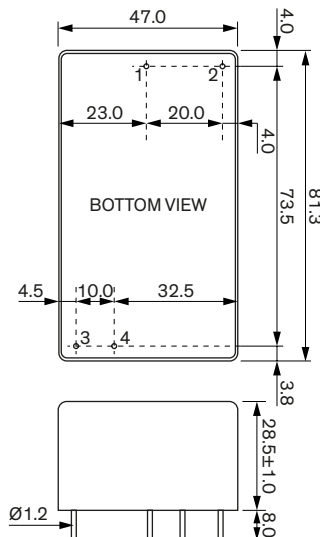

- Compact PCB power module in 3.2" x 1.85" package
- Wide input voltage range 90–305 VAC
- Certified according to EN 60335-1 and IEC/EN/UL 62368-1
- I/O-Isolation 4000 VAC
- Operating temperature range –40°C to +70°C
- No load input power <0.1 W (acc. ErP directive)
- High efficiency up to 83%
- Internal EN 55032 class B filter
- Protection class II prepared
- 3 year product warranty

Model	Output Voltage nom.	Output Current max.	Efficiency typ.
TMPW 80-112	12 VDC	6666 mA	89.5%
TMPW 80-115	15 VDC	5333 mA	89.5%
TMPW 80-124	24 VDC	3333 mA	90.5%
TMPW 80-148	48 VDC	1667 mA	90.5%

Pinout	
Pin	Single
1	AC (N)
2	AC (L)
3	+Vout
4	–Vout



TMPW 80-J/-T | 80 W

NEW
under
development

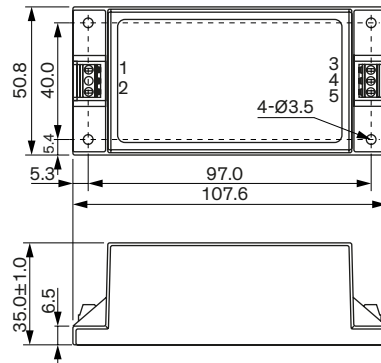

- Compact Chassis mount power module in 4.24" × 2.0" package
- Wide input voltage range 90–305 VAC
- Certified according to EN 60335-1 and IEC/EN/UL 62368-1
- I/O-Isolation 4000 VAC
- Operating temperature range –40°C to +70°C
- No load input power <0.1 W (acc. ErP directive)
- High efficiency up to 83%
- Internal EN 55032 class B filter
- Protection class II prepared
- 3 year product warranty

Model	Output Voltage nom.	Output Current max.	Efficiency typ.
TMPW 80-112-J/-T*	12 VDC	5000 mA	90%
TMPW 80-115-J/-T*	15 VDC	4000 mA	90%
TMPW 80-124-J/-T*	24 VDC	2500 mA	89%
TMPW 80-148-J/-T*	48 VDC	1250 mA	89%

* -J = JST connector
-T = Screw Terminal

Pinout	
Pin	Function
1	AC (N)
2	AC (L)
3	+Vout
4	NC
5	-Vout

- **J Input/Output:** B03B-PSILE-A1
mates w/ crimp terminal: SPSI-41T-M1.1 or SPS1-001T-M1.1
and terminal housing: PSIP-03V-LE-A
- **T Input/Output:** EK381V-03P

TMPW 100 | 100 W

NEW
under
development

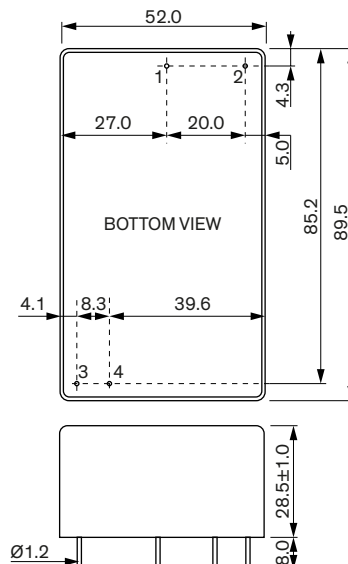

- Compact PCB power module in 3.5" × 2.05" package
- Wide input voltage range 90–305 VAC
- Certified according to EN 60335-1 and IEC/EN/UL 62368-1
- I/O-Isolation 4000 VAC
- Operating temperature range –40°C to +70°C
- No load input power <0.1 W (acc. ErP directive)
- High efficiency up to 83%
- Internal EN 55032 class B filter
- Protection class II prepared
- 3 year product warranty

Model	Output Voltage nom.	Output Current max.	Efficiency typ.
TMPW 100-112	12 VDC	8333 mA	88.5%
TMPW 100-115	15 VDC	6666 mA	90%
TMPW 100-124	24 VDC	4166 mA	88.5%
TMPW 100-148	48 VDC	2083 mA	90%

Pinout	
Pin	Single
1	AC (N)
2	AC (L)
3	+Vout
4	-Vout



TMPW 100-J/-T | 100 W

NEW
under
development

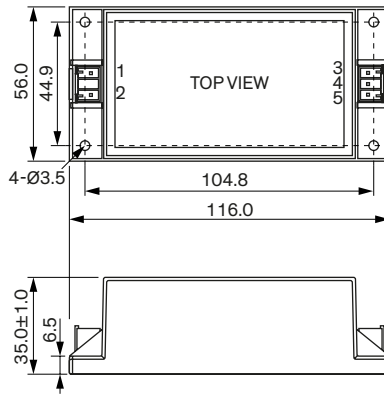

- Compact PCB power module in 4.57" x 2.2" package
- Wide input voltage range 90–305 VAC
- Certified according to EN 60335-1 and IEC/EN/UL 62368-1
- I/O-Isolation 4000 VAC
- Operating temperature range –40°C to +70°C
- No load input power <0.1 W (acc. ErP directive)
- High efficiency up to 83%
- Internal EN 55032 class B filter
- Protection class II prepared
- 3 year product warranty

Pinout	
Pin	Function
1	AC (N)
2	AC (L)
3	+Vout
4	NC
5	-Vout

Model	Output Voltage nom.	Output Current max.	Efficiency typ.
TMPW 100-112-J/-T*	12 VDC	8333 mA	88.5%
TMPW 100-115-J/-T*	15 VDC	6666 mA	90%
TMPW 100-124-J/-T*	24 VDC	4166 mA	88.5%
TMPW 100-148-J/-T*	48 VDC	2083 mA	90%

* -J = JST connector
-T = Screw Terminal

- **J Input/Output:** B03B-PSILE-A1
mates w/ crimp terminal: SPSI-41T-M1.1 or SPS1-001T-M1.1
and terminal housing: PSIP-03V-LE-A
- **T Input/Output:** EK381V-03P

DIN-Rail Mountable

- UL 62368-1/UL 60950-1 approved
- IEC/EN 61010-1 & 61010-2-201
- UL 508 approved (industrial environments)
- UL 1310 class II/NEC class 2 (TBL & TBLC only)
- EN 60335-1 approved for household applications (TBLC series)
- Low-profile form factor (TBL & TBLC) for flush box mounting
- Slim profile form factor (TPC & TCL) for industrial enclosures
- Uninterruptable power supply (UPS) with battery management (TSP-BCM & TSPC)



TBLC | 6-90 W

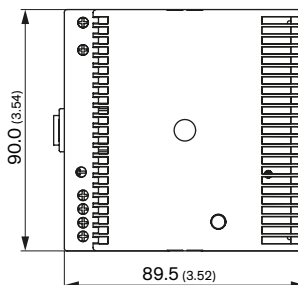
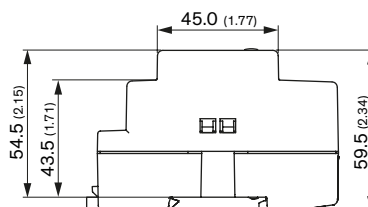

- High power density in low profile case, module depth only 55 mm
- For distributed power, suitable for mounting in domestic installation panels
- Low output ripples and spikes
- Very high efficiency and low standby current → compliance to ECO-Standard
- Suitable for household appliance and industrial applications
- UL 1310 class II, NEC class 2 compliance and UL 508 listed
- Universal input range 85 to 264 VAC
- Operating temperature range: -25°C to +70°C max.
- Short circuit and overload protection
- Adjustable output voltage and DC-OK indicator LED
- product warranty 3-year

Dimension Table		Weight
Model	Width [W]	[g]
TBLC 06	18 mm (0.71)	60
TBLC 15	27 mm (1.08)	80
TBLC 25	36 mm (1.42)	110
TBLC 50	54 mm (2.13)	180
TBLC 75	72 mm (2.83)	220
TBLC 90	90 mm (3.54)	280

Model	Output Power (max.)	Output Voltage* (nom.) (adjust.)	Output Current (max.)	Efficiency (typ.)
TBLC 06-105	6 W	5.0 VDC	1.2 A	74%
TBLC 06-112	6 W	12 VDC	0.5 A	81%
TBLC 06-124	6 W	24 VDC	0.25 A	79%
TBLC 15-105	12 W	5.0 VDC	2.4 A	81%
TBLC 15-112	15 W	12 VDC	1.25 A	85%
TBLC 15-124	15 W	24 VDC	0.63 A	85%
TBLC 25-105	20 W	5.0 VDC	4.0 A	82%
TBLC 25-112	24 W	12 VDC	2.0 A	86%
TBLC 25-124	25 W	24 VDC	1.05 A	87%
TBLC 50-112	48 W	12 VDC	4.0 A	88%
TBLC 50-124	50 W	24 VDC	2.1 A	89%
TBLC 75-112	72 W	12 VDC	6.0 A	89%
TBLC 75-124	75 W	24 VDC	3.1 A	89%
TBLC 90-112	90 W	12 VDC	7.5 A	90%
TBLC 90-124	90 W	24 VDC	3.75 A	90%

* Output voltage can be adjusted as indicated. However, output power has to be maintained at nominal value. This means the output nominal current has to be reduced in accordance with the increase of output voltage.



TBL | 15–150 W

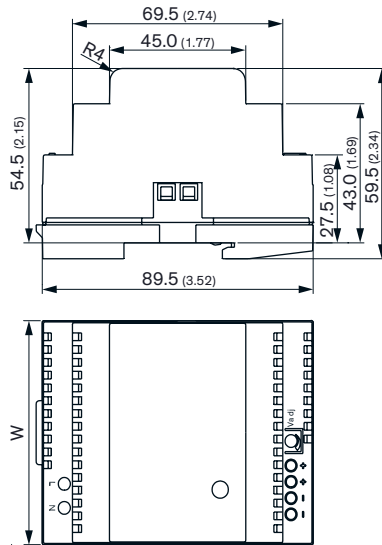

- Low profile case, module depth only 55 mm
- Fits into flat control panels used in building automation
- Safety class II product
- UL 1310 class II, NEC class 2 compliance (models up to 90 W)
- UL 508 listed
- 5 power ranges from 15 to 150 W
- Universal input range 85 to 264 VAC
- Operating temperature range: -25°C to +70°C max.
- Adjustable output voltage
- Short circuit and overload protection
- product warranty 3-year

Dimension Table		Weight
Model	Width [W]	[g]
TBL 015	26.3 mm (1.04)	100
TBL 030	52.5 mm (2.07)	160
TBL 060	70.0 mm (2.76)	230
TBL 090	105 mm (4.13)	340
TBL 150	175 mm (6.89)	625

Model	Output Power (max.)	Output Voltage* (nom.) (adjust.)	Output Current (max.)	Efficiency (typ.)
TBL 015-105	12 W	5.0 VDC	2.4 A	73%
TBL 015-112	15 W	12 VDC	1.25 A	79%
TBL 015-124	15 W	24 VDC	0.63 A	81%
TBL 030-112	30 W	12 VDC	2.5 A	81%
TBL 030-124	30 W	24 VDC	1.25 A	83%
TBL 060-112	54 W	12 VDC	4.5 A	83%
TBL 060-124	60 W	24 VDC	2.5 A	85%
TBL 090-112	72 W	12 VDC	6.0 A	84%
TBL 090-124	90 W	24 VDC	3.75 A	86%
TBL 150-112	120 W	12 VDC	10 A	84%
TBL 150-124	150 W	24 VDC	6.25 A	87%

TPC | 30–120 W

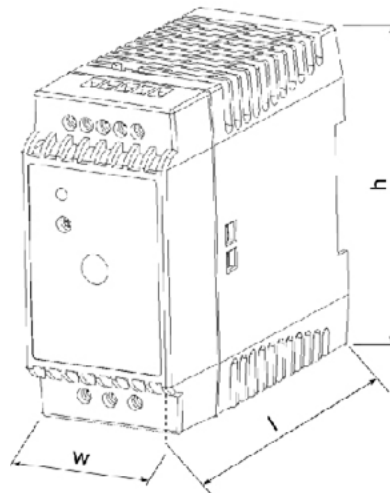

- For industrial, office and residential environments
- Meets European ErP directive (green mode), <0.3 W no load power consumption
- High efficiency across full load range
- Compact plastic case
- Reliable snap-on mounting on DIN-rails or with wall mounting bracket (not included)
- Output voltage adjustable
- Power good signal
- Low ripple and noise
- Overload and short-circuit protection
- Optional module for parallel and redundant operation
- product warranty 3-year

Dimension Table			
Model	Width [W]	Length [L]	Height [h]
TPC 30	26.5 mm (1.04)	96.5 mm (3.80)	90 mm (3.54)
TPC 55	45 mm (1.77)	96.5 mm (3.80)	90 mm (3.54)
TPC 80	63 mm (2.48)	96.5 mm (3.80)	90 mm (3.54)
TPC 120	72 mm (2.83)	110 mm (4.33)	90 mm (3.54)

Model	Input Voltage Ranges	Output Power max.	Output Voltage nom./ adj. range	Output Current (max.)
TPC 030-105	85–264 VAC	20 W	5.0 VDC/5.0–6.0 VDC	4.0 A
TPC 030-112		26 W	12 VDC/12–15 VDC	2.2 A
TPC 030-124		30 W	24 VDC/24–28.8 VDC	1.25 A
TPC 030-148		30 W	48 VDC/48–56 VDC	0.6 A
TPC 055-112	Universal Input	42 W	12 VDC/12–15 VDC	3.5 A
TPC 055-124		55 W	24 VDC/24–28.8 VDC	2.3 A
TPC 055-148	47/63 Hz	55 W	48 VDC/48–56 VDC	1.15 A
TPC 080-112		72 W	12 VDC/12–15 VDC	6.0 A
TPC 080-124		80 W	24 VDC/24–28.8 VDC	3.3 A
TPC 080-148		80 W	48 VDC/48–56 VDC	1.7 A
TPC 120-112	90–375 VDC	96 W	12 VDC/12–15 VDC	8.0 A
TPC 120-124		120 W	24 VDC/24–28.8 VDC	5.0 A
TPC 120-148		120 W	48 VDC/48–56 VDC	2.5 A



TCL | 24–240 W

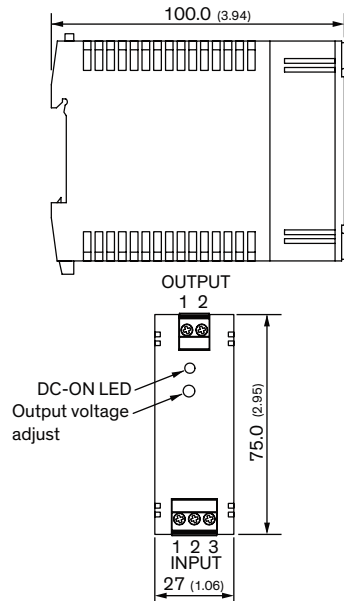

- For industrial, office and residential applications
- Ultracompact plastic housing
- Connection by spring clamp terminals or detachable screw terminal block
- Reliable snap-on mounting on DIN-rails
- Adaptor for wall mounting
- Universal input 85–264 VAC, 50/60 Hz
- Output voltage adjustable
- Power OK signal
- Low ripple and noise
- Overload and short-circuit protection
- product warranty 3-year

Dimension Table			
Model	Width [W]	Length [L]	Height [h]
TCL 024	27 mm (1.06)	100 mm (3.94)	75 mm (2.95)
TCL 60	45 mm (1.77)	100 mm (3.94)	75 mm (2.95)
TCL 120	85 mm (3.35)	100 mm (3.94)	75 mm (2.95)
TCL 240	85 mm (3.35)	125 mm (4.92)	110 mm (4.33)

Model	Input Voltage Ranges	Output Power max.	Output Voltage nom.	Output Current (max.)	Connection
TCL 024–105	85–264 VAC Universal Input 50/60 Hz	20 W	5 VDC	4.0 A	Detach-able screw terminal blocks
TCL 024–112		24 W	24 VDC	2.0 A	
TCL 024–124			1.0 A		
TCL 060–112	48 W	12 VDC	4.0 A		
TCL 060–124	60 W	24 VDC	2.5 A		
TCL 060–148	48 VDC	1.25 A			
TCL 120–112	85–375 VDC	96 W	12 VDC	8.0 A	Spring clamp terminals
TCL 120–124		120 W	24 VDC	5.0 A	
TCL 240–124		240 W	24 VDC	10.0 A	
TCL 024–124C	85–264 VAC Universal Input 50/60 Hz	24 W	24 VDC	1.0 A	
TCL 060–112C		48 W	12 VDC	4.0 A	
TCL 060–124C		60 W	24 VDC	2.5 A	
TCL 060–148C	48 VDC	1.25 A			
TCL 120–112C	85–375 VDC	96 W	12 VDC	8.0 A	
TCL 120–124C		120 W	24 VDC	5.0 A	

UPS SYSTEM | TSPC-240-124UPS | 240 W

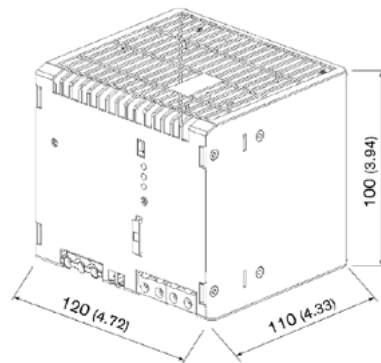

- Compact universal power supply for uninterruptable 24 VDC output voltage
- Battery protection for over voltage, deep discharge, short circuit and reverse connection
- Alarm outputs for input, output and battery condition
- Remote On/Off for UPS function and power supply
- Controlled end of charge voltage by battery temperature sensor
- International safety approval package
- Suitable for various external 12 VDC lead acid batteries
- 3-year product warranty

Model	Input Voltage Range	Output Current max.*	Back up Battery
TSPC 240-124 UPS	Low Line: 85–132 VAC	24 VDC / 12 A	12 V lead acid battery (to purchase on local market)
	High Line: 187–264 VAC		

* Maximum current at nominal Vout

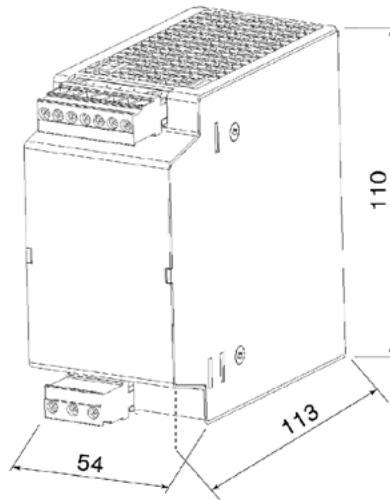
BATTERY CONTROLLER MODULES | TSP-BCMU | 360 W

- Battery controller module (BCM)
- Redundant inputs for two independent sources
- Alarm signals
- Input for 12 V battery
- Battery protection system
- Remote On/Off
- 3-year product warranty

Model	Inputs	Input Voltage Range	Output Current max.*	Back up Battery
TSP-BCMU360	2 x 360 W, for any single or two identical 24 VDC or 48 VDC sources	24–28 or 48–56 VDC (range selection with jumper)	24 VDC/15 A 48 VDC/7.5 A	12V lead acid battery (to purchase on local market, or TRACO POWER battery pack)

* Maximum current at nominal Vout

TRACO POWER dedicated to design and production of high quality, state-of-the-art DC/DC & AC/DC power conversion products. Our mission is to provide optimal power supply solutions for specific applications with regard to performance, quality, cost and functionality.

TRACO POWER stocks an average of USD 25+ million in available finished goods inventory for immediate shipment through our distribution partners.

TRACO POWER offers extended product life-cycles, typically 10+ years, and our products are supported by a 3 or 5 year product warranty. We understand our customers require a high quality solution as well as a diverse product offering, availability from stock, extended life-cycles and a strong commitment to quality in the form of extended warranty to support their business.

Our other selection guides / catalogues

Product Portfolio



Medical Power Solutions



Railway Power Solutions



Industrial Power Solutions



International Office

Traco Electronic AG
Sihlbruggstrasse 111
6340 Baar
Switzerland

P +41 43 311 45 11
F +41 43 311 45 45
info@tracopower.com

German Office

Traco Electronic GmbH
Oskar-Messter-Str. 20a
85737 Ismaning/München
Germany

P +49 89 96 11 82-0
F +49 89 96 11 82-20
info@tracopower.de

French Office

Traco Power France
2 rue du nouveau bercy
Bâtiment Le Levant
94220 Charenton Le Pont
France

P +33 (0)9 70 66 76 74
info@tracopower.fr

North America Office

Traco Power North America, Inc.
2025 Gateway Place #330
SAN JOSE, CA 95110
USA

P +1 (408) 916-4570
F +1 (408) 916-4571
salesusa@tracopower.com

Design & Development

Traco Power Solutions Ltd.
Whitemill Industrial Estate
Whitemill Road, Wexford
Y35 YH66, Ireland

P +353 53 9167 700
F +353 53 9167 701
info@tracopower.ie