

## Snubber MKP Capacitors for Pulse Applications with Double-Sided Metallized Electrodes, Schoopage Contacts and Internal Series Connection

### Special Features

- Pulse duty construction
- Self-healing
- Particularly reliable contact-configurations: 4-pin versions and screwable plate connections
- Internal series connection from 400 VAC
- Very low dissipation factor
- Negative capacitance change versus temperature
- According to RoHS 2011/65/EC

### Typical Applications

For high pulse and high frequency applications requiring extremely reliable contacts e.g.

- IGBT-applications

### Construction

#### Dielectric:

Polypropylene (PP) film

#### Capacitor electrodes:

Double-sided metallized plastic film

#### Internal construction:

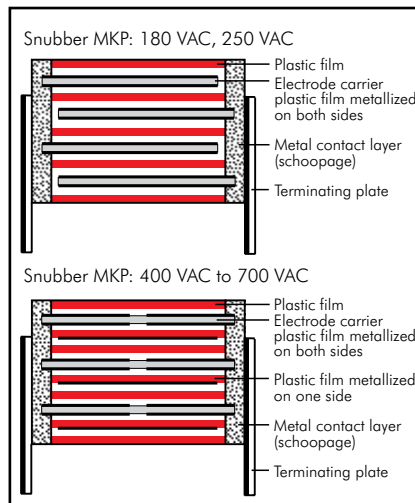

#### Encapsulation:

Solvent-resistant, flame-retardant plastic case with epoxy resin seal, UL 94 V-0

#### Terminations:

Tinned wire or plates.

#### Marking:

Colour: Red. Marking: Black.  
Epoxy resin seal: Red

### Electrical Data

**Capacitance range:** 0.047  $\mu$ F to 25  $\mu$ F

#### Rated voltages:

250 VDC, 400 VDC, 630 VDC, 1000 VDC, 1600 VDC, 2000 VDC, 3000 VDC

#### Capacitance tolerances:

$\pm 20\%$ ,  $\pm 10\%$ ,  $\pm 5\%$  (other tolerances are available subject to special enquiry)

#### Operating temperature range:

$-55^\circ\text{C}$  to  $+100^\circ\text{C}$

#### Insulation resistance at $+20^\circ\text{C}$ :

$C \leq 0.33 \mu\text{F}$ :  $\geq 1 \times 10^5 \text{ M}\Omega$

(mean value:  $5 \times 10^5 \text{ M}\Omega$ )

$C > 0.33 \mu\text{F}$ :  $\geq 30\,000 \text{ sec} (\text{M}\Omega \times \mu\text{F})$

(mean value: 100 000 sec)

Measuring voltage: 100 V/1 min.

#### Test voltage: 2 sec

L	$\leq 2000 \text{ VDC}$	3000 VDC
< 41.5	$1.6 U_r$	$1.2 U_r$
41.5	$1.4 U_r$	$1.2 U_r$
56	$1.2 U_r$	$1.2 U_r$

#### Climatic test category:

55/100/56 in accordance with IEC

#### Voltage derating:

A voltage derating factor of 1.35 % per K must be applied from  $+85^\circ\text{C}$  for DC voltages and from  $+75^\circ\text{C}$  for AC voltages

#### Reliability:

Operational life > 300 000 hours

Failure rate < 1 fit ( $0.5 \times U_r$  and  $40^\circ\text{C}$ )

#### Specific dissipation:

Box size* WxHxL in mm	Specific dissipation in Watts per K above the ambient temperature
19x31x56	0.068
23x34x56	0.079
27x37.5x56	0.092
33x48x56	0.122
37x54x56	0.142

\* other box sizes see page 10.

#### Dissipation factors at $+20^\circ\text{C}$ : $\tan \delta$

at f	$C \leq 0.1 \mu\text{F}$	$0.1 \mu\text{F} < C \leq 1.0 \mu\text{F}$	$C > 1.0 \mu\text{F}$
1 kHz	$\leq 3 \times 10^{-4}$	$\leq 3 \times 10^{-4}$	$\leq 3 \times 10^{-4}$
10 kHz	$\leq 4 \times 10^{-4}$	$\leq 6 \times 10^{-4}$	-
100 kHz	$\leq 15 \times 10^{-4}$	-	-

#### Maximum pulse rise time:

Capacitance $\mu\text{F}$	max. pulse rise time V/ $\mu\text{sec}$ at $T_A < 40^\circ\text{C}$						
	250 VDC	400 VDC	630 VDC	1000 VDC	1600 VDC	2000 VDC	3000 VDC
0.047 ... 0.22	500	500	900	1400	1400	1400	1400
0.33 ... 0.68	300	400	700	900	900	900	900
1.0 ... 2.2	200	200	400	400	500	500	500
2.5 ... 6.8	80	100	150	300	400	-	-
7.0 ... 10	50	70	75	-	-	-	-
15 ... 25	35	50	-	-	-	-	-

for pulses equal to the rated voltage

### Mounting Recommendation

Excessive mechanical strain, e.g. pressure or shock onto the capacitor body, is to be avoided during mounting and usage of the capacitors. When fixing the plates the screw torque is to be limited to max. 5 Nm.

For further details and graphs please refer to Technical Information.

### Packing

Packing units at the end of the catalogue.

Packing quantities may vary depending on the plate version.

## Continuation

### General Data

Capacitance	250 VDC/180 VAC*				400 VDC/250 VAC*				630 VDC/400 VAC*			
	W	H	L	Part number	W	H	L	Part number	W	H	L	Part number
0.1 $\mu$ F					7	14	18	SNMPG031004D	7	16.5	26.5	SNMPJ031005D
0.15 "					8	15	18	SNMPG031504F	8.5	18.5	26.5	SNMPJ031505F
0.22 "	7	14	18	SNMPF032204D	7	16.5	26.5	SNMPG032205D	10.5	19	26.5	SNMPJ032205G
0.33 "	8	15	18	SNMPF033304F	8.5	18.5	26.5	SNMPG033305F	11	21	26.5	SNMPJ033305I
0.47 "	7	16.5	26.5	SNMPF034705D	10.5	19	26.5	SNMPG034705G	11	21	31.5	SNMPJ034706B
0.68 "	8.5	18.5	26.5	SNMPF036805F	11	21	31.5	SNMPG036806B	15	26	31.5	SNMPJ036806F
									13	24	41.5	SNMPJ036807C
1.0 $\mu$ F	11	21	26.5	SNMPF041005I	13	24	31.5	SNMPG041006D	17	29	31.5	SNMPJ041006G
					13	24	41.5	SNMPG041007C	15	26	41.5	SNMPJ041007D
1.5 "	13	24	31.5	SNMPF041506D	17	29	31.5	SNMPG041506G	19	32	41.5	SNMPJ041507F
	11	22	41.5	SNMPF041507B	15	26	41.5	SNMPG041507D				
2.0 "	15	26	31.5	SNMPF042006F	17	29	41.5	SNMPG042007E	20	39.5	41.5	SNMPJ042007G
	13	24	41.5	SNMPF042007C								
2.2 "	15	26	31.5	SNMPF042206F	17	29	41.5	SNMPG042207E	20	39.5	41.5	SNMPJ042207G
	13	24	41.5	SNMPF042207C								
2.5 "	17	29	31.5	SNMPF042506G	19	32	41.5	SNMPG042507F	24	45.5	41.5	SNMPJ042507H
	15	26	41.5	SNMPF042507D								
3.0 "	17	34.5	31.5	SNMPF043006I	20	39.5	41.5	SNMPG043007G	24	45.5	41.5	SNMPJ043007H
	15	26	41.5	SNMPF043007D								
3.3 "	17	34.5	31.5	SNMPF043306I	20	39.5	41.5	SNMPG043307G	24	45.5	41.5	SNMPJ043307H
	15	26	41.5	SNMPF043307D								
4.0 "	19	32	41.5	SNMPF044007F	24	45.5	41.5	SNMPG044007H	31	46	41.5	SNMPJ044007I
4.7 "	19	32	41.5	SNMPF044707F	24	45.5	41.5	SNMPG044707H	31	46	41.5	SNMPJ044707I
5.0 "	20	39.5	41.5	SNMPF045007G	24	45.5	41.5	SNMPG045007H	31	46	41.5	SNMPJ045007I
6.0 "	20	39.5	41.5	SNMPF046007G	31	46	41.5	SNMPG046007I	35	50	41.5	SNMPJ046007J
6.8 "									33	48	56	SNMPJ046008J
									40	55	41.5	SNMPJ046807K
7.0 "	24	45.5	41.5	SNMPF047007H	31	46	41.5	SNMPG047007I	33	48	56	SNMPJ047008J
8.0 "	24	45.5	41.5	SNMPF048007H	33	48	56	SNMPG048008J	37	54	56	SNMPJ048008L
10.0 $\mu$ F	31	46	41.5	SNMPF051007I	35	50	41.5	SNMPG051007J				
					33	48	56	SNMPG051008J				
15.0 "	35	50	41.5	SNMPF051507J	40	55	41.5	SNMPG051507K				
	33	48	56	SNMPF051508J	37	54	56	SNMPG051508L				
20.0 "	37	54	56	SNMPF052008L								
25.0 "	37	54	56	SNMPF052508L								

\* AC voltage:  $f \leq 1000 \text{ Hz}$ ;  $1.4 \times U_{\text{rms}} + \text{UDC} \leq U_r$

     New box sizes

Dims in mm.

Ionisation inception level in isolated cases may be lower than admissible rated AC voltage.

Versions and dimensional drawings see page 93.

Rights reserved to amend design data without prior notification.

Part number completion:

Version codes see page 96.

Tolerance: 20 % = M

10 % = K

5 % = J

Packing: bulk = S

Pin length: 6-2 = SD

none = 00 (for plate versions)

Continuation page 88

## Continuation

### General Data

Capacitance	1000 VDC/600 VAC*				1600 VDC/650 VAC*			
	W	H	L	Part number	W	H	L	Part number
0.068 µF	7	16.5	26.5	SNMPO126805D_____	10.5	19	26.5	SNMPT026805G_____
0.1 µF	8.5	18.5	26.5	SNMPO131005F_____	11	21	26.5	SNMPT031005I_____
0.15 "	11	21	26.5	SNMPO131505I_____	13	24	31.5	SNMPT031506D_____
0.22 "	11	21	31.5	SNMPO132206B_____	11	22	41.5	SNMPT031507B_____
					15	26	31.5	SNMPT032206F_____
					13	24	41.5	SNMPT032207C_____
0.33 "	15	26	31.5	SNMPO133306F_____	17	34.5	31.5	SNMPT033306I_____
					13	24	41.5	SNMPT033307C_____
0.47 "	17	29	31.5	SNMPO134706G_____	15	26	41.5	SNMPT033307D_____
					19	32	41.5	SNMPT034707F_____
0.68 "	15	26	41.5	SNMPO134707D_____	17	29	41.5	SNMPT034707F_____
1.0 µF	20	39.5	41.5	SNMPO141007G_____	24	45.5	41.5	SNMPT041007H_____
	23	34	56	SNMPO141008E_____				
1.5 "	24	45.5	41.5	SNMPO141507H_____	31	46	41.5	SNMPT041507I_____
	23	34	56	SNMPO141508E_____				
2.0 "	31	46	41.5	SNMPO142007I_____	40	55	41.5	SNMPT042007K_____
	27	37.5	56	SNMPO142008H_____	33	48	56	SNMPT042008J_____
2.2 "	31	46	41.5	SNMPO142207I_____	40	55	41.5	SNMPT042207K_____
	27	37.5	56	SNMPO142208H_____	33	48	56	SNMPT042208J_____
2.5 "	35	50	41.5	SNMPO142507J_____	37	54	56	SNMPT042508L_____
	33	48	56	SNMPO142508J_____				
3.0 "	40	55	41.5	SNMPO143007K_____	37	54	56	SNMPT043008L_____
	33	48	56	SNMPO143008J_____				
3.3 "	40	55	41.5	SNMPO143307K_____				
	33	48	56	SNMPO143308J_____				
4.0 "	37	54	56	SNMPO144008L_____				
4.7 "	37	54	56	SNMPO144708L_____				
5.0 "	37	54	56	SNMPO145008L_____				

\* AC voltage:  $f \leq 1000 \text{ Hz}$ ;  $1.4 \times U_{\text{rms}} + \text{UDC} \leq U_r$

     New box sizes

Dims. in mm.

Ionisation inception level in isolated cases may be lower than admissible rated AC voltage.

Versions and dimensional drawings see page 93.

#### Part number completion:

Version codes see page 96.

Tolerance: 20 % = M

10 % = K

5 % = J

Packing: bulk = S

Pin length: 6-2 = SD

none = 00 (for plate versions)

Rights reserved to amend design data without prior notification.

Continuation page 89

## Continuation

### General Data

Capacitance	2000 VDC/700 VAC*				3000 VDC/700 VAC*			
	W	H	L	Part number	W	H	L	Part number
0.047 $\mu\text{F}$	10.5	19	26.5	SNMPU024705G	11	21	31.5	SNMPW024706B
0.068 "	11	21	26.5	SNMPU026805I	13	24	31.5	SNMPW026806D
					11	22	41.5	SNMPW026807B
0.1 $\mu\text{F}$	13	24	31.5	SNMPU031006D	15	26	31.5	SNMPW031006F
	11	22	41.5	SNMPU031007B	13	24	41.5	SNMPW031007C
0.15 "	15	26	31.5	SNMPU031506F	15	26	41.5	SNMPW031507D
	13	24	41.5	SNMPU031507C				
0.22 "	17	34.5	31.5	SNMPU032206I	19	32	41.5	SNMPW032207F
	15	26	41.5	SNMPU032207D				
0.33 "	19	32	41.5	SNMPU033307F	24	45.5	41.5	SNMPW033307H
					19	31	56	SNMPW033308D
0.47 "	20	39.5	41.5	SNMPU034707G	31	46	41.5	SNMPW034707I
					27	37.5	56	SNMPW034708H
0.68 "	24	45.5	41.5	SNMPU036807H	35	50	41.5	SNMPW036807J
					33	48	56	SNMPW036808J
1.0 $\mu\text{F}$	35	50	41.5	SNMPU041007J	40	55	41.5	SNMPW041007K
	33	48	56	SNMPU041008J	33	48	56	SNMPW041008J
1.5 "	40	55	41.5	SNMPU041507K	37	54	56	SNMPW041508L
	33	48	56	SNMPU041508J				
2.0 "	37	54	56	SNMPU042008L				

\* AC voltage:  $f \leq 1000 \text{ Hz}$ ;  $1.4 \times U_{\text{rms}} + U_{\text{DC}} \leq U_{\text{r}}$

     New box sizes

Dims. in mm.

Ionisation inception level in isolated cases may be lower than admissible rated AC voltage.

Versions and dimensional drawings see page 93.

Rights reserved to amend design data without prior notification.

Part number completion:

Version codes see page 96.

Tolerance: 20 % = M

10 % = K

5 % = J

Packing: bulk = S

Pin length: 6-2 = SD

none = 00 (for plate versions)

Permissible AC voltage in relation to frequency at 10° C internal temperature rise (general guide).

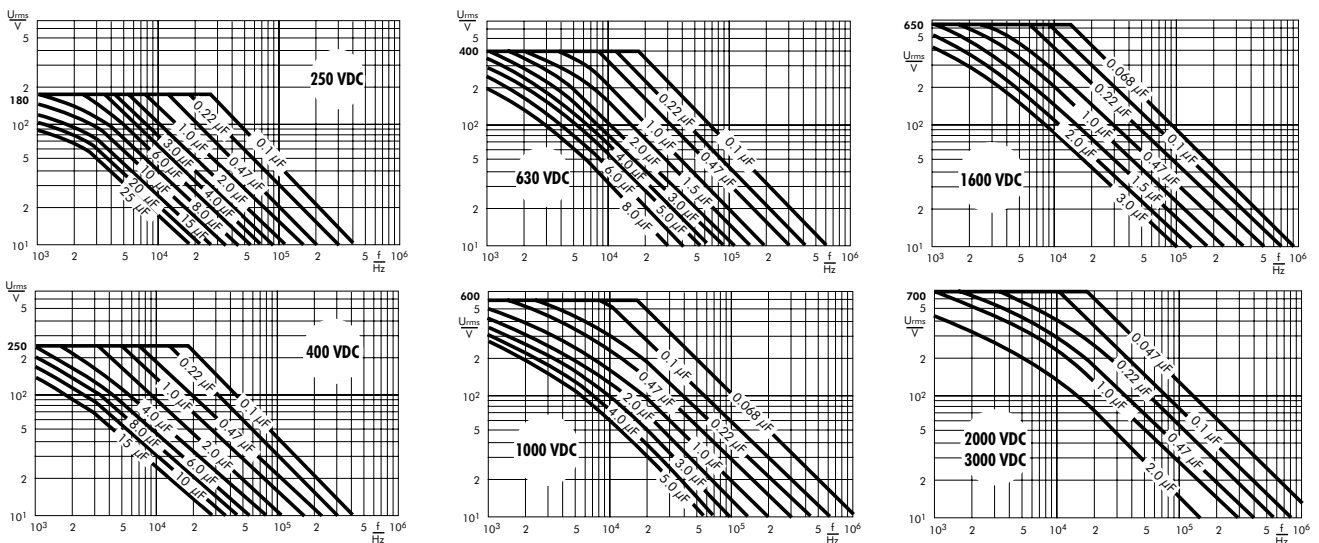

# Versions of WIMA Snubber Capacitors

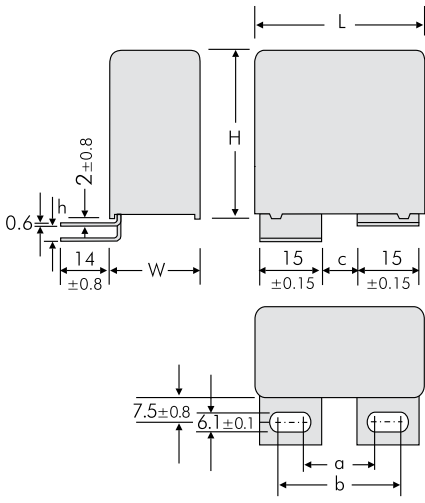

Version	L	a ±0.5	b ±0.5	c ±0.5	h ±0.8
<b>A1</b>	41.5	17.5	27.5	7.5	0
<b>A1.5</b>	41.5	17.5	27.5	7.5	3.5
<b>A1</b>	56	20	30	10	0
<b>A1.1.1</b>	56	28	38	18	0
<b>A1.4</b>	56	20	30	10	3.5
<b>A1.4.1</b>	56	28	38	18	3.5

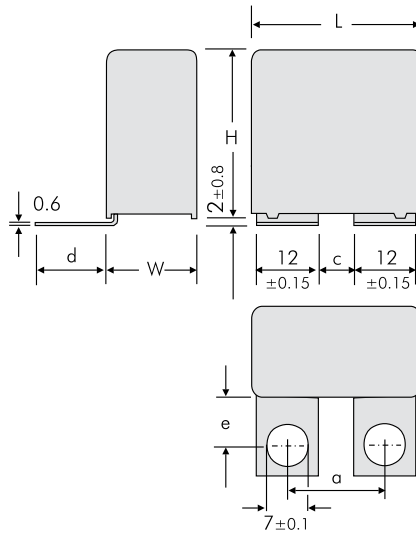

Version	L	a ±0.5	c ±0.5	d ±0.8	e ±0.8
<b>A1.6</b>	41.5	18	6	21.5	16
<b>A1.6.1</b>	41.5	22	10	18.5	13
<b>A1.6</b>	56	29	17	21.5	16

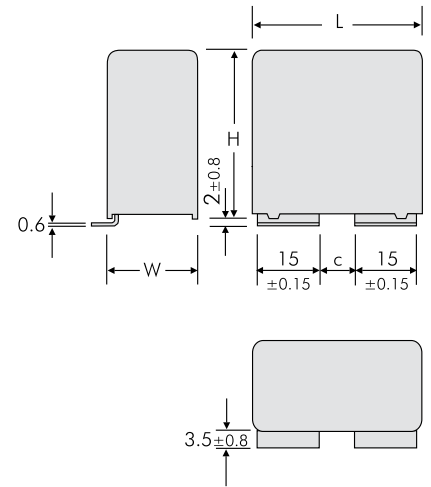

Version	L	c ±0.5
<b>A1.7</b>	41.5	7.5
<b>A1.7</b>	56	10
<b>A1.7.1</b>	56	18

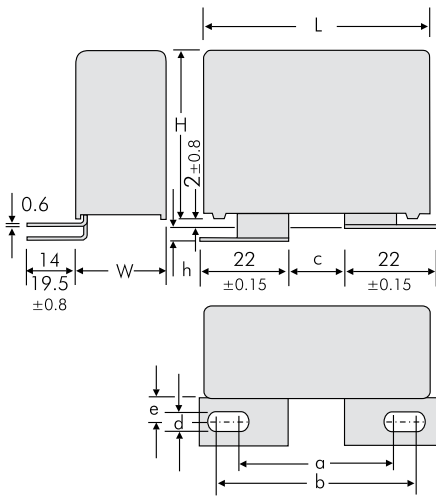

Version	L	a ±0.5	b ±0.5	c ±0.5	d ±0.1	e ±0.8	h ±0.8
<b>A2</b>	41.5	40.5	46.5	14.5	8.4	7.5	0
<b>A2.2</b>	41.5	31	37	5	8.4	7.5	3.5
<b>A2.3</b>	41.5	31	37	5	8.4	13	3.5
<b>A2.4</b>	41.5	33.5	39.5	7.5	8.4	13	3.5
<b>A2.4.1</b>	41.5	33.5	39.5	7.5	8.4	13	0
<b>A2.5</b>	41.5	29.5	39.5	5.5	6.1	7.5	3.5
<b>A2.6</b>	41.5	31.5	41.5	7.5	6.1	13	3.5
<b>A2.6.1</b>	41.5	31.5	41.5	14	6.1	13	3.5
<b>A2.6.2</b>	41.5	31.5	41.5	14	6.1	13	0
<b>A2.8</b>	41.5	40.5	46.5	14.5	8.4	7.5	3.5
<b>A2.1</b>	56	39.5	45.5	13.5	8.4	7.5	0
<b>A2.7</b>	56	39.5	45.5	13.5	8.4	7.5	3.5

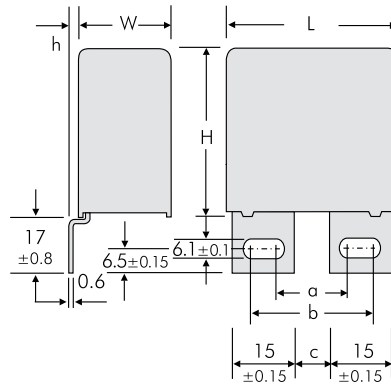

Version	L	a ±0.5	b ±0.5	c ±0.5	h ±0.8
<b>A3</b>	41.5	17.5	27.5	7.5	0
<b>A3.5</b>	41.5	17.5	27.5	7.5	3
<b>A3</b>	56	20	30	10	0
<b>A3.1</b>	56	28	38	18	0
<b>A3.5</b>	56	20	30	10	3
<b>A3.10</b>	56	28	38	18	3

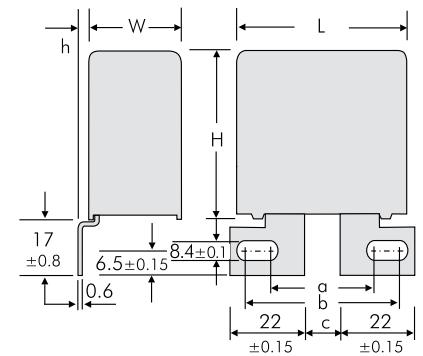

Version	L	a ±0.5	b ±0.5	c ±0.5	h ±0.8
<b>A3.9</b>	41.5	40.5	46.5	14.5	0
<b>A3.11</b>	41.5	40.5	46.5	14.5	3
<b>A3.2</b>	56	40.5	46.5	14.5	0
<b>A3.3</b>	56	40.5	46.5	14.5	3

# Versions of WIMA Snubber Capacitors

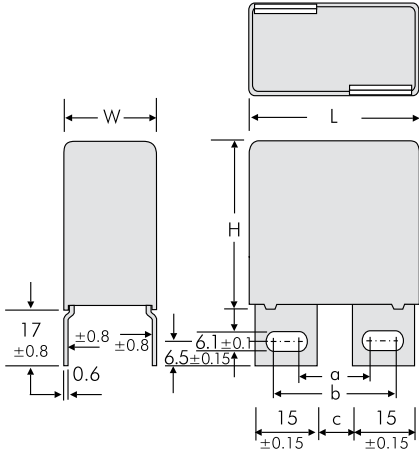

Version	L	a ±0.5	b ±0.5	c ±0.5
<b>A3.6</b>	41.5	17.5	27.5	7.5
<b>A3.7</b>	56	20	30	10

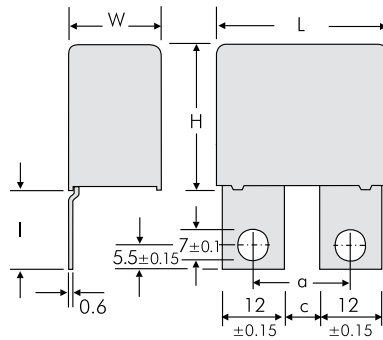

Version	L	a ±0.5	c ±0.5	I ±0.8
<b>A3.8</b>	41.5 W ≥ 17	18	6	23
<b>A3.8.1</b>	41.5 W ≥ 17	22	10	17.5

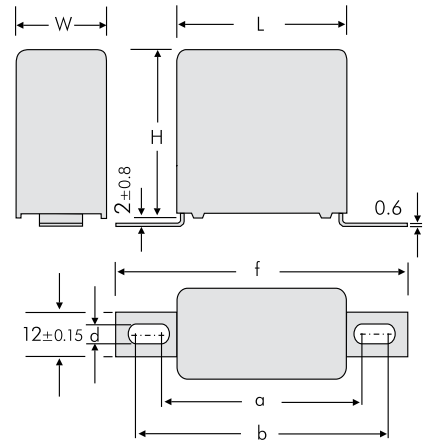

Version	L	a ±0.8	b ±0.8	f ±0.8	d ±0.1
<b>A4.9</b>	31.5 W ≥ 15	44	47	57	4.5
<b>A4.10</b>	31.5 W ≥ 15	43	59	69	6.1
<b>A4.2</b>	41.5 W ≥ 15	54	57	67	4.5
<b>A4</b>	41.5 W ≥ 15	53	69	79	6.1
<b>A4.7</b>	56	65	68	78	4.5
<b>A4</b>	56	64	80	90	6.1

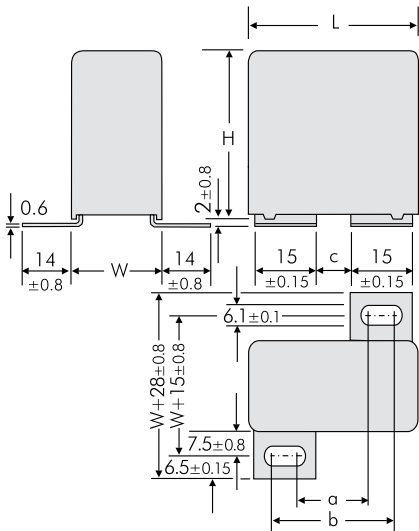

Version	L	a ±0.5	b ±0.5	c ±0.5
<b>A5</b>	41.5	17.5	27.5	7.5
<b>A5</b>	56	20	30	10

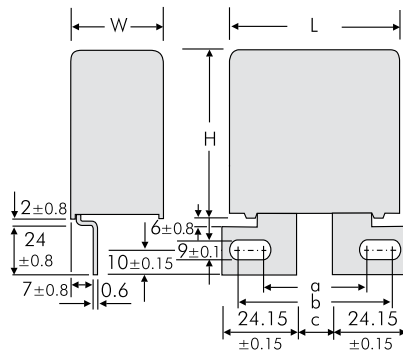

Version	L	a ±0.5	b ±0.5	c ±0.5
<b>A6</b>	56 W ≥ 23	41.5	45.5	15.5

# Versions of WIMA Snubber Capacitors



**Version FS 6.3**  
with slip-on terminals according to DIN 46244

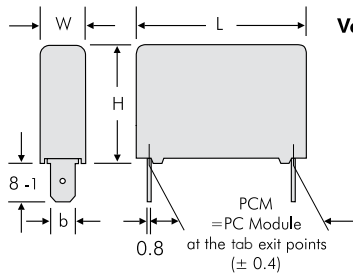

L	W	PCM	b ±0.15
26.5	≥ 11	23.5	6.3
31.5	≥ 11	28.5	6.3
41.5	≥ 11	38.5	6.3
56	≥ 11	49.5	6.3

**Version B\***

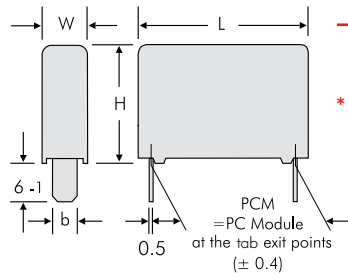

L	PCM	b ±0.15
18	16	5
26.5	23.5	5
31.5	28.5	8
41.5	38.5	8
56	49.5	8

\* Processing notification:  
Processing should be done within 3 month after manufacturing.

**2-pin version**

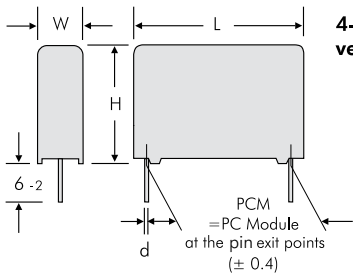

PCM	d
15	0.8
22.5	0.8
27.5	0.8
38.5	1.2
49.5	1.2

**4-pin version**

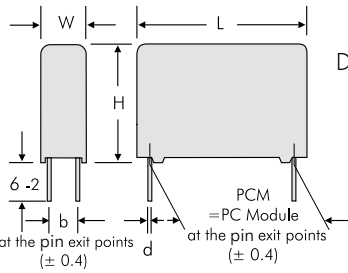

W	H	L	PCM	b	d
10.5	19	26.5	22.5	5	0.8
10.5	20.5	26.5	22.5	5	0.8
11	21	26.5	22.5	5	0.8
11	21	31.5	27.5	5	0.8
13	24	31.5	27.5	7.5	0.8
15	26	31.5	27.5	7.5	0.8
17	29	31.5	27.5	10	0.8
17	34.5	31.5	27.5	10	0.8
20	39.5	31.5	27.5	12.5	0.8
22	43.5	31.5	27.5	12.5	0.8
11	22	41.5	37.5	5	1
13	24	41.5	37.5	7.5	1
15	26	41.5	37.5	7.5	1
17	29	41.5	37.5	10	1
19	32	41.5	37.5	10	1
20	39.5	41.5	37.5	12.5	1
24	45.5	41.5	37.5	12.5	1
31	46	41.5	37.5	20	1
19	31	56	48.5	12.5	1
23	34	56	48.5	15	1
27	37.5	56	48.5	15	1
33	48	56	48.5	20	1
37	54	56	48.5	20	1

Dims. in mm.

Additional special versions can be realized. Please contact us with your specific needs.

# Versions of WIMA Snubber Capacitors



Version code		D2	D4	B5*	B8*	1A	1B	1F	1G	1H	1I	1J	1K	1L	2A	2B	2C	2D	2E	2F	2H	2I	2J	2K	2L	2M	3A	3C	3D	3E	3G	3I	3J	3K	3L	3N	3O	3P	
W x H x L	Size code	2-pin	4-pin	B5	B8	A1	A1.1.1	A1.4	A1.4.1	A1.5	A1.6	A1.6.1	A1.7	A1.7.1	A2	A2.1	A2.2	A2.3	A2.4	A2.4.1	A2.5	A2.6	A2.6.1	A2.6.2	A2.7	A2.8	A3	A3.1	A3.2	A3.3	A3.5	A3.6	A3.7	A3.8	A3.8.1	A3.9	A3.10	A3.11	
7 x 14 x 18	<b>4D</b>																																						
8 x 15 x 18	<b>4F</b>																																						
7 x 16.5 x 26.5	<b>5D</b>																																						
8.5 x 18.5 x 26.5	<b>5F</b>																																						
10.5 x 19 x 26.5	<b>5G</b>																																						
10.5 x 20.5 x 26.5	<b>5H</b>																																						
11 x 21 x 26.5	<b>5I</b>																																						
11 x 21 x 31.5	<b>6B</b>																																						
13 x 24 x 31.5	<b>6D</b>																																						
15 x 26 x 31.5	<b>6F</b>																																						
17 x 29 x 31.5	<b>6G</b>																																						
17 x 34.5 x 31.5	<b>6I</b>																																						
11 x 22 x 41.5	<b>7B</b>																																						
13 x 24 x 41.5	<b>7C</b>																																						
15 x 26 x 41.5	<b>7D</b>																																						
17 x 29 x 41.5	<b>7E</b>																																						
19 x 32 x 41.5	<b>7F</b>																																						
20 x 39.5 x 41.5	<b>7G</b>																																						
24 x 45.5 x 41.5	<b>7H</b>																																						
31 x 46 x 41.5	<b>7I</b>																																						
35 x 50 x 41.5	<b>7J</b>																																						
40 x 55 x 41.5	<b>7K</b>																																						
19 x 31 x 56	<b>8D</b>																																						
23 x 34 x 56	<b>8E</b>																																						
27 x 37.5 x 56	<b>8H</b>																																						
33 x 48 x 56	<b>8J</b>																																						

Version code		4A	4C	4J	4L	4M	5A	6A	FS
W x H x L	Size code	A4	A4.2	A4.7	A4.9	A4.10	A5	A6	FS 6.3
11 x 21 x 26.5	<b>5I</b>								
11 x 21 x 31.5	<b>6B</b>								
13 x 24 x 31.5	<b>6D</b>								
15 x 26 x 31.5	<b>6F</b>								
17 x 29 x 31.5	<b>6G</b>								
17 x 34.5 x 31.5	<b>6I</b>								
11 x 22 x 41.5	<b>7B</b>								
13 x 24 x 41.5	<b>7C</b>								
15 x 26 x 41.5	<b>7D</b>								
17 x 29 x 41.5	<b>7E</b>								
19 x 32 x 41.5	<b>7F</b>								
20 x 39.5 x 41.5	<b>7G</b>								
24 x 45.5 x 41.5	<b>7H</b>								
31 x 46 x 41.5	<b>7I</b>								
19 x 31 x 56	<b>8D</b>								
23 x 34 x 56	<b>8E</b>								
27 x 37.5 x 56	<b>8H</b>								
33 x 48 x 56	<b>8J</b>								

Possible connecting respective plate versions - depending on box size.

\* Processing notification:  
Processing should be done within 3 month after manufacturing.

# Typical Dimensions for Taping Configuration

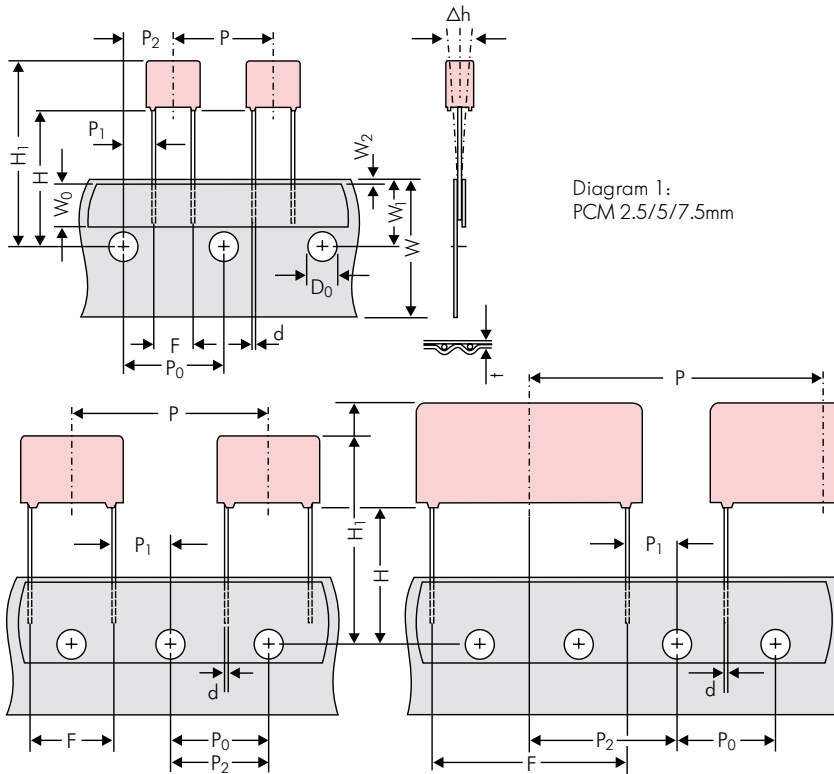

Diagram 2: PCM 10/15 mm

Diagram 3: PCM 22.5 and 27.5\*mm

\*PCM 27.5 tapping possible with two feed holes between components

Designation	Symbol	Dimensions for Radial Taping										
		PCM 2.5 tapping	PCM 5 tapping	PCM 7.5 tapping	PCM 10 tapping*	PCM 15 tapping*	PCM 22.5 tapping	PCM 27.5 tapping				
Carrier tape width	W	18.0 ±0.5	18.0 ±0.5	18.0 ±0.5	18.0 ±0.5	18.0 ±0.5	18.0 ±0.5	18.0 ±0.5				
Hold-down tape width	W <sub>0</sub>	6.0 for hot-sealing adhesive tape	6.0 for hot-sealing adhesive tape	12.0 for hot-sealing adhesive tape	12.0 for hot-sealing adhesive tape	12.0 for hot-sealing adhesive tape	12.0 for hot-sealing adhesive tape	12.0 for hot-sealing adhesive tape				
Hole position	W <sub>1</sub>	9.0 ±0.5	9.0 ±0.5	9.0 ±0.5	9.0 ±0.5	9.0 ±0.5	9.0 ±0.5	9.0 ±0.5				
Hold-down tape position	W <sub>2</sub>	0.5 to 3.0 max.	0.5 to 3.0 max.	0.5 to 3.0 max.	0.5 to 3.0 max.	0.5 to 3.0 max.	0.5 to 3.0 max.	0.5 to 3.0 max.				
Feed hole diameter	D <sub>0</sub>	4.0 ±0.2	4.0 ±0.2	4.0 ±0.2	4.0 ±0.2	4.0 ±0.2	4.0 ±0.2	4.0 ±0.2				
Pitch of component	P	12.7 ±1.0	12.7 ±1.0	12.7 ±1.0	25.4 ±1.0	25.4 ±1.0	38.1 ±1.5	38.1 ±1.5 or 50.8 ±1.5				
Feed hole pitch	P <sub>0</sub>	12.7 ±0.3 cumulative pitch error max. 1.0 mm/20 pitch	12.7 ±0.3 cumulative pitch error max. 1.0 mm/20 pitch	12.7 ±0.3 cumulative pitch error max. 1.0 mm/20 pitch	12.7 ±0.3 cumulative pitch error max. 1.0 mm/20 pitch	12.7 ±0.3 cumulative pitch error max. 1.0 mm/20 pitch	12.7 ±0.3 cumulative pitch error max. 1.0 mm/20 pitch	12.7 ±0.3 cumulative pitch error max. 1.0 mm/20 pitch				
Feed hole centre to pin	P <sub>1</sub>	5.1 ±0.5	3.85 ±0.7	2.6 ±0.7	7.7 ±0.7	5.2 ±0.7	7.8 ±0.7	5.3 ±0.7				
Hole centre to component centre	P <sub>2</sub>	6.35 ±1.3	6.35 ±1.3	6.35 ±1.3	12.7 ±1.3	12.7 ±1.3	19.05 ±1.3	19.05 ±1.3				
Feed hole centre to bottom edge of the component	H	16.5 ±0.3 18.5 ±0.5	16.5 ±0.3 18.5 ±0.5	16.5 ±0.5 18.5 ±0.5	16.5 ±0.5 18.5 ±0.5	16.5 ±0.5 18.5 ±0.5	16.5 ±0.5 18.5 ±0.5	16.5 ±0.5 18.5 ±0.5				
Feed hole centre to top edge of the component	H <sub>1</sub>	H+H <sub>component</sub> < H <sub>1</sub> 32.25 max.	H+H <sub>component</sub> < H <sub>1</sub> 32.25 max.	H+H <sub>component</sub> < H <sub>1</sub> 24.5 to 31.5	H+H <sub>component</sub> < H <sub>1</sub> 25.0 to 31.5	H+H <sub>component</sub> < H <sub>1</sub> 26.0 to 37.0	H+H <sub>component</sub> < H <sub>1</sub> 30.0 to 43.0	H+H <sub>component</sub> < H <sub>1</sub> 35.0 to 45.0				
Pin spacing at upper edge of carrier tape	F	2.5 ±0.5	5.0 <sup>+0.8</sup> <sub>-0.2</sub>	7.5 ±0.8	10.0 ±0.8	15 ±0.8	22.5 ±0.8	27.5 ±0.8				
Pin diameter	d	0.4 ±0.05	0.5 ±0.05	0.5 ±0.05 or 0.6 <sup>+0.06</sup> <sub>-0.05</sub>	0.5 ±0.05 or 0.6 <sup>+0.06</sup> <sub>-0.05</sub>	0.8 <sup>+0.08</sup> <sub>-0.05</sub>	0.8 <sup>+0.08</sup> <sub>-0.05</sub>	0.8 <sup>+0.08</sup> <sub>-0.05</sub>				
Component alignment	Δh	± 2.0 max.	± 2.0 max.	± 3.0 max.	± 3.0 max.	± 3.0 max.	± 3.0 max.	± 3.0 max.				
Total tape thickness	t	0.7 ±0.2	0.7 ±0.2	0.7 ±0.2	0.7 ±0.2	0.7 ±0.2	0.7 ±0.2	0.7 ±0.2				
Package (see also page 149)	ROLL/AMMO			AMMO								
	REEL	φ 360 max. φ 30 ±1	B 52 ±2 58 ±2	depending on comp. dimensions		REEL	φ 360 max. φ 30 ±1	52 ±2 58 ±2 or 66 ±2	REEL	φ 500 max. φ 25 ±1	54 ±2 60 ±2 68 ±2	depending on PCM and component dimensions
Unit	see details page 150.											

Dims in mm.

\* Diameter of pins see General Data.

\* PCM 10 and PCM 15 can be crimped to PCM 7.5.

Position of components according to PCM 7.5 (sketch 11). P<sub>0</sub> = 12.7 or 15.0 is possible

Please clarify customer-specific deviations with the manufacturer.

## Types of Tape Packaging of Capacitors for Automatic Radial Insertion

### ■ ROLL Packaging

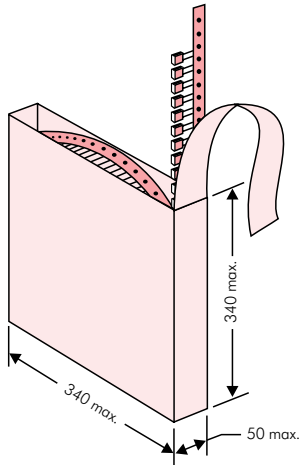

### ■ AMMO Packaging

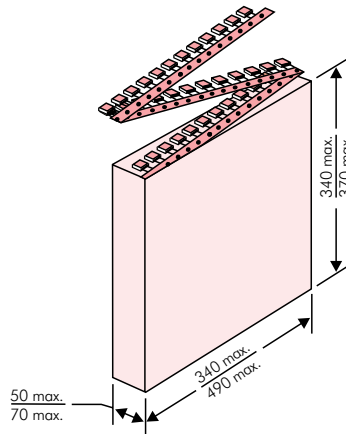

### ■ REEL Packaging

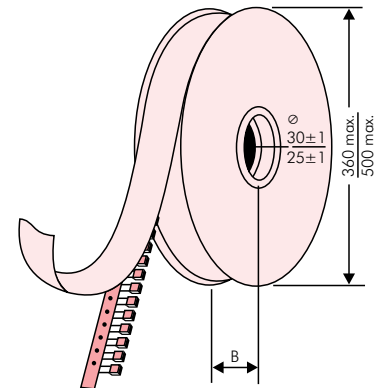

## BAR CODE (Labelling)

Labelling of package units in plain text and with alphanumerical Bar Code

Scanner decoding of

- WIMA supplier number
- Customer's P/O number
- Customer's part number
- WIMA confirmation number
- WIMA part number
- Lot number
- Date code
- Quantity

In addition part description of

- article
- capacitance value
- rated voltage
- dimensions
- capacitance tolerance
- packing

as well as gross weight and customer's name are indicated in plain text.

<b>WIMA</b> Best Capacitors Made in Germany		Werk Unna	
Supplier-ID: 123456789	<b>RoHS</b> 2011/65/EC	Date Code: 08.10.10	
Purchase Order No. (P/O): Bestellung xyz		Quantity: 5.000	
Customer Part No.: KUNDETEILENUMMER		Customer No.: 0000100002	
		Gross Weight [g]: 1870	
WIMA Confirmation No.: 0001004053000100	WIMA Part No.: MKS2C034701C00K88D		
Handling Unit: <b>MKS 2</b>	<b>QTY: 5.000</b>	<b>COO: DE</b>	
	<b>MKS 2 0.47 µF 63 VDC 3.5x8.5x7.2 RMS</b>		
<b>1000067326</b>	Standard 10% Loss - Standard	Drahte 6-2	Week 03/2011
	Vorlage Debitor Inland		

BARCODE „Code 39“



## Packing Quantities for Capacitors with Radial Pins in PCM 2.5 mm to 22.5 mm

PCM	Size				bulk	pcs. per packing unit								
						ROLL		REEL				AMMO		
	W	H	L	Codes		S	H16.5	H18.5	ø 360	ø 500	340 × 340	490 × 370		
					N	O	F	I	H	J	A	C	B	D
<b>2.5 mm</b>	2.5	7	4.6	<b>0B</b>	5000		2200	2500				2800		
	3	7.5	4.6	<b>0C</b>	5000		2000	2300				2300		
	3.8	8.5	4.6	<b>0D</b>	5000		1500	1800				1800		
	4.6	9	4.6	<b>0E</b>	5000		1200	1500				1500		
	5.5	10	4.6	<b>0F</b>	5000		900	1200				1200		
<b>5 mm</b>	2.5	6.5	7.2	<b>1A</b>	5000		2200	2500				2800		
	3	7.5	7.2	<b>1B</b>	5000		2000	2300				2300		
	3.5	8.5	7.2	<b>1C</b>	5000		1600	2000				2000		
	4.5	6	7.2	<b>1D</b>	6000		1300	1500				1500		
	4.5	9.5	7.2	<b>1E</b>	4000		1300	1500				1500		
	5	10	7.2	<b>1F</b>	3500		1100	1400				1400		
	5.5	7	7.2	<b>1G</b>	4000		1000	1200				1200		
	5.5	11.5	7.2	<b>1H</b>	2500		1000	1200				1200		
	6.5	8	7.2	<b>1I</b>	2500		800	1000				1000		
	7.2	8.5	7.2	<b>1J</b>	2500		700	1000				1000		
	7.2	13	7.2	<b>1K</b>	2000		700	950				1000		
	8.5	10	7.2	<b>1L</b>	2000		600	800				800		
	8.5	14	7.2	<b>1M</b>	1500		600	800				800		
11	16	7.2	<b>1N</b>	1000		500	600				400			
<b>7.5 mm</b>	2.5	7	10	<b>2A</b>	5000			2500	4400		2500			
	3	8.5	10	<b>2B</b>	5000			2200	4300		2300		4150	
	4	9	10	<b>2C</b>	4000			1700	3200		1700		3100	
	4.5	9.5	10.3	<b>2D</b>	3500			1500	2900		1400		2800	
	5	10.5	10.3	<b>2E</b>	3000			1300	2500		1300			
	5.7	12.5	10.3	<b>2F</b>	2000			1000	2200		1100			
	7.2	12.5	10.3	<b>2G</b>	1500			900	1800		1000			
<b>10 mm</b>	3	9	13	<b>3A</b>	3000			1100	2200				1900	
	4	8.5	13.5	<b>FA</b>	3000			900	1600				1450	
	4	9	13	<b>3C</b>	3000			900	1600				1450	
	4	9.5	13	<b>3D</b>	3000			900	1600				1400	
	5	10	13.5	<b>FB</b>	2000			700	1300				1200	
	5	11	13	<b>3F</b>	3000			700	1300				1200	
	6	12	13	<b>3G</b>	2400			550	1100				1000	
	6	12.5	13	<b>3H</b>	2400			550	1100				1000	
8	12	13	<b>3I</b>	2000			400	800				740		
<b>15 mm</b>	5	11	18	<b>4B</b>	2400			600	1200				1150	
	5	13	19	<b>FC</b>	1000			600	1200				1200	
	6	12.5	18	<b>4C</b>	2000			500	1000				1000	
	6	14	19	<b>FD</b>	1000			500	1000				1000	
	7	14	18	<b>4D</b>	1600			450	900				850	
	7	15	19	<b>FE</b>	1000			450	900				850	
	8	15	18	<b>4F</b>	1200			400	800				740	
	8	17	19	<b>FF</b>	500			400	800				740	
	9	14	18	<b>4H</b>	1200			350	700				650	
	9	16	18	<b>4J</b>	900			350	700				650	
	10	18	19	<b>FG</b>	500			300	650				590	
11	14	18	<b>4M</b>	1000			300	600				540		
<b>22.5 mm</b>	5	14	26.5	<b>5A</b>	1200				800				770	
	6	15	26.5	<b>5B</b>	1000				700				640	
	7	16.5	26.5	<b>5D</b>	760				600				550	
	8	20	28	<b>FH</b>	500				500				480	
	8.5	18.5	26.5	<b>5F</b>	500				480				450	
	10	22	28	<b>FI</b>	540*				420				380	
	10.5	19	26.5	<b>5G</b>	680*				400				360	
	10.5	20.5	26.5	<b>5H</b>	680*				400				360	
	11	21	26.5	<b>5I</b>	680*				380				350	
	12	24	28	<b>FJ</b>	450*				350				310	

\* TPS (Tray-Packing-System). Plate versions may have different packing units. Samples and pre-production needs on request.

■ Moulded versions.

Rights reserved to amend design data without prior notification.

## Packing Quantities for Capacitors with Radial Pins in PCM 27.5 mm to 52.5 mm



PCM	Size				bulk	pcs. per packing unit									
						ROLL		REEL				AMMO			
	W	H	L	Codes		S	N	O	ø 360		ø 500		340 × 340		490 × 370
								H16.5	H18.5	H16.5	H18.5	H16.5	H18.5	H16.5	H18.5
								F	I	H	J	A	C	B	D
<b>27.5 mm</b>	9	19	31.5	<b>6A</b>	640*	–	–	–	–	460/340*	–	–	420		
	11	21	31.5	<b>6B</b>	544*	–	–	–	–	380/280*	–	–	350		
	13	24	31.5	<b>6D</b>	448*	–	–	–	–	300	–	–	290		
	13	25	33	<b>6K</b>	336*	–	–	–	–	–	–	–	–		
	15	26	31.5	<b>6F</b>	384*	–	–	–	–	270	–	–	250		
	15	26	33	<b>6L</b>	288*	–	–	–	–	–	–	–	–		
	17	29	31.5	<b>6G</b>	176*	–	–	–	–	–	–	–	–		
	17	34.5	31.5	<b>6I</b>	176*	–	–	–	–	–	–	–	–		
	20	32	33	<b>6M</b>	216*	–	–	–	–	–	–	–	–		
	20	39.5	31.5	<b>6J</b>	144*	–	–	–	–	–	–	–	–		
<b>37.5 mm</b>	9	19	41.5	<b>7A</b>	480*	–	–	–	–	–	–	–	–		
	11	22	41.5	<b>7B</b>	408*	–	–	–	–	–	–	–	–		
	13	24	41.5	<b>7C</b>	252*	–	–	–	–	–	–	–	–		
	15	26	41.5	<b>7D</b>	144*	–	–	–	–	–	–	–	–		
	17	29	41.5	<b>7E</b>	132*	–	–	–	–	–	–	–	–		
	19	32	41.5	<b>7F</b>	108*	–	–	–	–	–	–	–	–		
	20	39.5	41.5	<b>7G</b>	108*	–	–	–	–	–	–	–	–		
	24	45.5	41.5	<b>7H</b>	84*	–	–	–	–	–	–	–	–		
	31	46	41.5	<b>7I</b>	72*	–	–	–	–	–	–	–	–		
	35	50	41.5	<b>7J</b>	35*	–	–	–	–	–	–	–	–		
40	55	41.5	<b>7K</b>	28*	–	–	–	–	–	–	–	–			
<b>48.5 mm</b>	19	31	56	<b>8D</b>	50*	–	–	–	–	–	–	–	–		
	23	34	56	<b>8E</b>	72*	–	–	–	–	–	–	–	–		
	27	37.5	56	<b>8H</b>	60*	–	–	–	–	–	–	–	–		
	33	48	56	<b>8J</b>	48*	–	–	–	–	–	–	–	–		
	37	54	56	<b>8L</b>	25*	–	–	–	–	–	–	–	–		
<b>52.5 mm</b>	35	50	57	<b>9F</b>	25*	–	–	–	–	–	–	–	–		
	45	55	57	<b>9H</b>	20*	–	–	–	–	–	–	–	–		
	45	65	57	<b>9J</b>	20*	–	–	–	–	–	–	–	–		

\* for 2-inch transport pitches.

\* TPS (Tray-Packing-System). Plate versions may have different packing units. Samples and pre-production needs on request.

■ Moulded versions. Rights reserved to amend design data without prior notification.



A WIMA part number consists of 18 digits and is composed as follows:

- Field 1 - 4: Type description
- Field 5 - 6: Rated voltage
- Field 7 - 10: Capacitance
- Field 11 - 12: Size and PCM
- Field 13 - 14: Version code (e.g. Snubber versions)
- Field 15: Capacitance tolerance
- Field 16: Packing
- Field 17 - 18: Pin length (untaped)

1	2	3	4	5	6	7	8	9	10	11	12	13	14	15	16	17	18
<b>M</b>	<b>K</b>	<b>S</b>	<b>2</b>	<b>C</b>	<b>0</b>	<b>2</b>	<b>1</b>	<b>0</b>	<b>0</b>	<b>1</b>	<b>A</b>	<b>0</b>	<b>0</b>	<b>M</b>	<b>S</b>	<b>S</b>	<b>D</b>
MKS 2				63 VDC		0.01 µF			2.5x6.5x7.2		-		20%	bulk	6-2		

<p><b>Type description:</b></p> <p>SMD-PET = SMDT              SMD-PPS = SMDI              FKP 02 = FKP0              MKS 02 = MKS0              FKS 2 = FKS2              FKP 2 = FKP2              MKS 2 = MKS2              MKP 2 = MKP2              FKS 3 = FKS3              FKP 3 = FKP3              MKS 4 = MKS4              MKP 4 = MKP4              MKP 10 = MKP1              FKP 4 = FKP4              FKP 1 = FKP1              MKP-X2 = MKX2              MKP-X2 R = MKXR              MKP-Y2 = MKY2              MP 3-X2 = MPX2              MP 3-X1 = MPX1              MP 3-Y2 = MPY2              MP 3R-Y2 = MPRY              Snubber MKP = SNMP              Snubber FKP = SNFP              GTO MKP = GTOM              DC-LINK MKP 3 = DCP3              DC-LINK MKP 4 = DCP4              DC-LINK MKP 4S = DCPS              DC-LINK MKP 5 = DCP5              DC-LINK MKP 6 = DCP6              DC-LINK HC = DCH_              DC-LINK HY = DCHY              SuperCap C = SCSC              SuperCap MC = MC_              SuperCap C60 = SCSC              SuperCap R = SCSR              SuperCap MR = MRPP</p>	<p><b>Rated voltage:</b></p> <p>2.5 VDC = A1              4 VDC = A2              14 VDC = A3              28 VDC = A4              40 VDC = A5              5 VDC = A6              50 VDC = B0              63 VDC = C0              100 VDC = D0              160 VDC = E0              250 VDC = F0              400 VDC = G0              450 VDC = H0              600 VDC = I0              630 VDC = J0              700 VDC = K0              800 VDC = L0              850 VDC = M0              900 VDC = N0              1000 VDC = O1              1100 VDC = P0              1200 VDC = Q0              1250 VDC = R0              1500 VDC = S0              1600 VDC = T0              2000 VDC = U0              2500 VDC = V0              3000 VDC = W0              4000 VDC = X0              6000 VDC = Y0              250 VAC = 0W              275 VAC = 1W              300 VAC = 2W              400 VAC = 3W              440 VAC = 4W              500 VAC = 5W              ...</p>	<p><b>Capacitance:</b></p> <p>22 pF = 0022              47 pF = 0047              100 pF = 0100              150 pF = 0150              220 pF = 0220              330 pF = 0330              470 pF = 0470              680 pF = 0680              1000 pF = 1100              1500 pF = 1150              2200 pF = 1220              3300 pF = 1330              4700 pF = 1470              6800 pF = 1680              0.01 µF = 2100              0.022 µF = 2220              0.047 µF = 2470              0.1 µF = 3100              0.22 µF = 3220              0.47 µF = 3470              1 µF = 4100              2.2 µF = 4220              4.7 µF = 4470              10 µF = 5100              22 µF = 5220              47 µF = 5470              100 µF = 6100              220 µF = 6220              1 F = A010              2.5 F = A025              50 F = A500              100 F = B100              110 F = B110              600 F = B600              1200 F = C120              ...</p>	<p><b>Size:</b></p> <p>4.8x3.3x3 Size 1812 = KA              4.8x3.3x4 Size 1812 = KB              5.7x5.1x3.5 Size 2220 = QA              5.7x5.1x4.5 Size 2220 = QB              7.2x6.1x3 Size 2824 = TA              7.2x6.1x5 Size 2824 = TB              10.2x7.6x5 Size 4030 = VA              12.7x10.2x6 Size 5040 = XA              15.3x13.7x7 Size 6054 = YA              2.5x7x4.6 PCM 2.5 = 0B              3x7.5x4.6 PCM 2.5 = 0C              2.5x6.5x7.2 PCM 5 = 1A              3x7.5x7.2 PCM 5 = 1B              2.5x7x10 PCM 7.5 = 2A              3x8.5x10 PCM 7.5 = 2B              3x9x13 PCM 10 = 3A              4x9x13 PCM 10 = 3C              5x11x18 PCM 15 = 4B              6x12.5x18 PCM 15 = 4C              5x14x26.5 PCM 22.5 = 5A              6x15x26.5 PCM 22.5 = 5B              9x19x31.5 PCM 27.5 = 6A              11x21x31.5 PCM 27.5 = 6B              9x19x41.5 PCM 37.5 = 7A              11x22x41.5 PCM 37.5 = 7B              94x49x182 DCH_ = H0              94x77x182 DCH_ = H1              ...</p> <p><b>Version code:</b></p> <p>Standard = 00              Version A1 = 1A              Version A1.1.1 = 1B              Version A2 = 2A              ...</p>	<p><b>Tolerance:</b></p> <p>20% = M              10% = K              5% = J              2.5% = H              1% = E              ...</p> <p><b>Packing:</b></p> <p>AMMO H16.5 340x340 = A              AMMO H16.5 490x370 = B              AMMO H18.5 340x340 = C              AMMO H18.5 490x370 = D              REEL H16.5 360 = F              REEL H16.5 500 = H              REEL H18.5 360 = I              REEL H18.5 500 = J              ROLL H16.5 = N              ROLL H18.5 = O              BLISTER W12 180 = P              BLISTER W12 330 = Q              BLISTER W16 330 = R              BLISTER W24 330 = T              Bulk/TPS Standard = S              ...</p> <p><b>Pin length (untaped)</b></p> <p>3.5 ±0.5 = C9              6-2 = SD              16 ±1 = P1              ...</p>
---	---	---	--	---

The data on this page is not complete and serves only to explain the part number system. Part number information is listed on the pages of the respective WIMA range.