

Snubber MKP Capacitors for Pulse Applications with Double-Sided Metallized Electrodes, Schoopage Contacts and Internal Series Connection

Special Features

- Pulse duty construction
- Self-healing
- Particularly reliable contact-configurations: 4-lead versions and screwable plate connections
- Internal series connection from 400 VAC
- Very low dissipation factor
- Negative capacitance change versus temperature
- According to RoHS 2002/95/EC

Typical Applications

- For high pulse and high frequency applications requiring extremely reliable contacts e.g.
- IGBT-applications

Construction

Dielectric:

Polypropylene (PP) film

Capacitor electrodes:

Double-sided metallized plastic film

Internal construction:

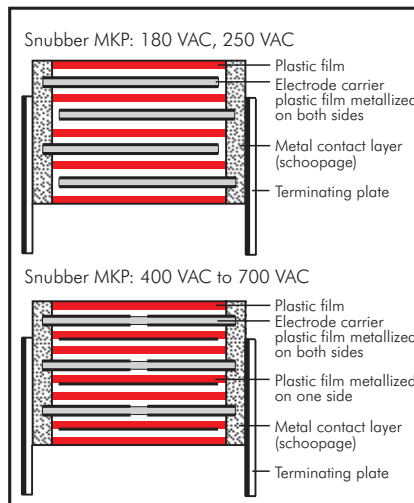

Encapsulation:

Solvent-resistant, flame-retardent plastic case with epoxy resin seal, UL 94 V-0

Terminations:

Tinned wire or plates.

Marking:

Colour: Red. Marking: Black.
Epoxy resin seal: Red

Electrical Data

Capacitance range:

0.047 μ F to 25 μ F

Rated voltages:

250 VDC, 400 VDC, 630 VDC, 1000 VDC, 1600 VDC, 2000 VDC, 3000 VDC

Capacitance tolerances:

$\pm 20\%$, $\pm 10\%$, $\pm 5\%$ (other tolerances are available subject to special enquiry)

Operating temperature range:

-55° C to $+100^{\circ}$ C

Climatic test category:

55/100/56 in accordance with IEC

Insulation resistance at $+20^{\circ}$ C:

$C \leq 0.33 \mu\text{F}$: $\geq 1 \times 10^5 \text{ M}\Omega$

(mean value: $5 \times 10^5 \text{ M}\Omega$)

$C > 0.33 \mu\text{F}$: $\geq 30\,000 \text{ sec (M}\Omega \times \mu\text{F)}$

(mean value: 100 000 sec)

Measuring voltage: 100 V/1 min.

Dissipation factors at $+20^{\circ}$ C: $\tan \delta$

at f	$C \leq 0.1 \mu\text{F}$	$0.1 \mu\text{F} < C \leq 1.0 \mu\text{F}$	$C > 1.0 \mu\text{F}$
1 kHz	$\leq 3 \times 10^{-4}$	$\leq 3 \times 10^{-4}$	$\leq 3 \times 10^{-4}$
10 kHz	$\leq 4 \times 10^{-4}$	$\leq 6 \times 10^{-4}$	-
100 kHz	$\leq 15 \times 10^{-4}$	-	-

Maximum pulse rise time:

Capacitance μF	max. pulse rise time V/ μsec at $T_A < 40^{\circ}$ C						
	250 VDC	400 VDC	630 VDC	1000 VDC	1600 VDC	2000 VDC	3000 VDC
0.047 ... 0.22	500	500	900	1400	1400	1400	1400
0.33 ... 0.68	300	400	700	900	900	900	900
1.0 ... 2.2	200	200	400	400	500	500	500
2.5 ... 6,0	80	100	150	300	400	-	-
7.0 ... 10	50	70	75	-	-	-	-
15 ... 25	10	20	-	-	-	-	-

for pulses equal to the rated voltage

Mounting Recommendation

Excessive mechanical strain, e.g. pressure or shock onto the capacitor body, is to be avoided during mounting and usage of the capacitors. When fixing the plates the screw torque is to be limited to max. 5 Nm.

Packing

Transportation-safe packing in cardboard boxes.

For further details and graphs please refer to Technical Information.

Continuation

General Data

Capacitance	250 VDC/180 VAC*			400 VDC/250 VAC*			630 VDC/400 VAC*			1000 VDC/600 VAC*			1600 VDC/650 VAC*			2000 VDC/700 VAC*			3000 VDC/700 VAC*					
	W	H	L	W	H	L	W	H	L	W	H	L	W	H	L	W	H	L	W	H	L			
0.047 μF										7	16.5	26.5	10.5	19	26.5	10.5	19	26.5	11	21	31.5	11	21	31.5
0.068 "																						11	22	41.5
0.1 μF	5	11	18	7	14	18	7	16.5	26.5	8.5	18.5	26.5	11	21	26.5	13	24	31.5	15	26	31.5	15	26	31.5
0.15 "	6	12.5	18	8	15	18	8.5	18.5	26.5	11	21	26.5	13	24	31.5	15	26	31.5	15	26	31.5	15	26	31.5
0.22 "	7	14	18	7	16.5	26.5	10.5	19	26.5	11	21	31.5	15	26	31.5	17	34.5	31.5	19	32	41.5	19	32	41.5
0.33 "	8	15	18	8.5	18.5	26.5	11	21	26.5	15	26	31.5	17	34.5	31.5	19	32	41.5	19	31	56			
0.47 "	7	16.5	26.5	10.5	19	26.5	11	21	31.5	17	29	31.5	19	32	41.5	20	39.5	41.5	27	37.5	56			
0.68 "	8.5	18.5	26.5	11	21	31.5	15	26	31.5	17	29	41.5	20	39.5	41.5	24	45.5	41.5	33	48	56			
1.0 μF	11	21	26.5	13	24	31.5	17	29	31.5	20	39.5	41.5	24	45.5	41.5	33	48	56	33	48	56			
1.5 "	13	24	31.5	17	29	31.5	19	32	41.5	24	45.5	41.5	31	46	41.5	33	48	56	37	54	56			
2.0 "	15	26	31.5	17	29	41.5	20	39.5	41.5	31	46	41.5	33	48	56	37	54	56						
2.2 "	15	26	31.5	17	29	41.5	20	39.5	41.5	31	46	41.5	33	48	56									
2.5 "	17	29	31.5	19	32	41.5	24	45.5	41.5	33	48	56	37	54	56									
3.0 "	15	26	41.5																					
3.3 "	17	34.5	31.5	20	39.5	41.5	24	45.5	41.5	33	48	56	37	54	56									
4.0 "	15	26	41.5																					
4.7 "	19	32	41.5	24	45.5	41.5	31	46	41.5	37	54	56												
5.0 "	19	32	41.5	24	45.5	41.5	31	46	41.5	37	54	56												
6.0 "	20	39.5	41.5	24	45.5	41.5	31	46	41.5	37	54	56												
7.0 "	20	39.5	41.5	31	46	41.5	33	48	56															
8.0 "	24	45.5	41.5	31	46	41.5	33	48	56															
10.0 μF	31	46	41.5	33	48	56																		
15.0 "	33	48	56	37	54	56																		
20.0 "	37	54	56																					
25.0 "	37	54	56																					

* AC voltage:
 $f \leq 1000 \text{ Hz}; 1.4 \times U_{\text{rms}} + \text{UDC} \leq U_r$

On ordering please state the required version and box size.

Versions and dimensional drawings see page 80.

Dims. in mm.

Ionisation inception level in isolated cases may be lower than admissible rated AC voltage.

Rights reserved to amend design data without prior notification.

Permissible AC voltage in relation to frequency at 10° C internal temperature rise (general guide).

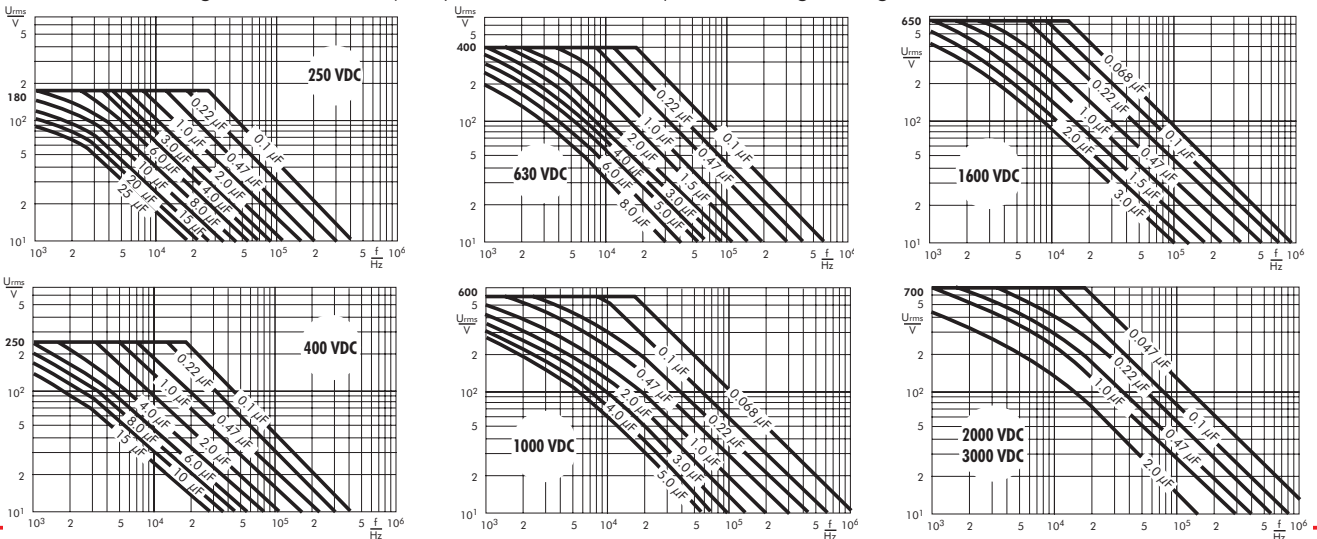

Snubber FKP Capacitors for High Pulse Applications with Metal Foil Electrodes, Schoopage Contacts and Self-Healing Internal Series Connection

Special Features

- High pulse duty
- Self-healing
- Particularly reliable contact-configurations: 4-lead versions and screwable plate connections
- Internal series connection
- Very low dissipation factor
- Negative capacitance change versus temperature
- According to RoHS 2002/95/EC

Typical Applications

- For high pulse and high frequency applications requiring extremely reliable contacts e.g.
- IGBT-applications

Construction

Dielectric:

Polypropylene (PP) film

Capacitor electrodes:

Aluminium foil and single-sided metallized plastic film

Internal construction:

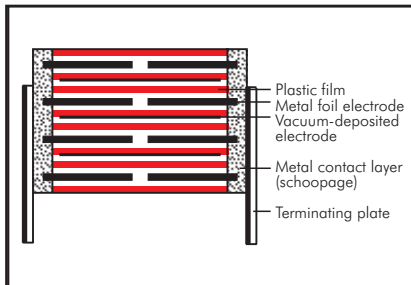

Encapsulation:

Solvent-resistant, flame-retardent plastic case with epoxy resin seal, UL 94 V-0

Terminations:

Tinned wire or plates.

Marking:

Colour: Red. Marking: Black.
Epoxy resin seal: Red

Electrical Data

Capacitance range:

0.01 μF to 2.2 μF

Rated voltages:

630 VDC, 1000 VDC, 1600 VDC, 2000 VDC, 3000 VDC, 4000 VDC

Capacitance tolerances:

$\pm 20\%$, $\pm 10\%$, $\pm 5\%$ (other tolerances are available subject to special enquiry)

Operating temperature range:

-55°C to $+100^\circ\text{C}$

Climatic test category:

55/100/56 in accordance with IEC

Insulation resistance at $+20^\circ\text{C}$:

$C \leq 0.33 \mu\text{F}$: $\geq 1 \times 10^5 \text{ M}\Omega$

(mean value: $5 \times 10^5 \text{ M}\Omega$)

$C > 0.33 \mu\text{F}$: $\geq 30\,000 \text{ sec (M}\Omega \times \mu\text{F)}$

(mean value: 100 000 sec)

Measuring voltage: 100 V/1 min.

Dissipation factors at $+20^\circ\text{C}$: $\tan \delta$

at f	$C \leq 0.1 \mu\text{F}$	$0.1 \mu\text{F} < C \leq 1.0 \mu\text{F}$	$C > 1.0 \mu\text{F}$
1 kHz	$\leq 3 \times 10^{-4}$	$\leq 3 \times 10^{-4}$	$\leq 3 \times 10^{-4}$
10 kHz	$\leq 4 \times 10^{-4}$	$\leq 6 \times 10^{-4}$	–
100 kHz	$\leq 10 \times 10^{-4}$	–	–

Maximum pulse rise time:

Capacitance μF	max. pulse rise time V/ μsec at $T_A < 40^\circ\text{C}$					
	630 VDC	1000 VDC	1600 VDC	2000 VDC	3000 VDC	4000 VDC
0.01 ... 0.022	–	11000	11000	11000	11000	11000
0.033 ... 0.068	9000	9000	9000	9000	9000	9000
0.1 ... 0.22	9000	9000	9000	9000	9000	9000
0.33 ... 0.68	5000	5000	5000	5000	5000	5000
1.0 ... 2.2	1600	2000	–	–	–	–

for pulses equal to the rated voltage

Mounting Recommendation

Excessive mechanical strain, e.g. pressure or shock onto the capacitor body, is to be avoided during mounting and usage of the capacitors. When fixing the plates the screw torque is to be limited to max. 5 Nm.

Packing

Transportation-safe packing in cardboard boxes.

For further details and graphs please refer to Technical Information.

Continuation

General Data

Capacitance	630 VDC/400 VAC*			1000 VDC/600 VAC*			1600 VDC/650 VAC*			2000 VDC/700 VAC*			3000 VDC/700 VAC*			4000 VDC/700 VAC*		
	W	H	L	W	H	L	W	H	L	W	H	L	W	H	L	W	H	L
0.01 μF							7	16.5	26.5	10.5	20.5	26.5	11	21	26.5	11	21	31.5
0.015 "							8.5	18.5	26.5	11	21	26.5	11	21	31.5	11	22	41.5
0.022 "				7	16.5	26.5	10.5	20.5	26.5	11	21	31.5	13	24	31.5	13	24	41.5
										11	22	41.5						
0.033 "				8.5	18.5	26.5	11	21	31.5	13	24	41.5	13	24	41.5	15	26	41.5
0.047 "	7	16.5	26.5	10.5	20.5	26.5	11	22	41.5	15	26	41.5	15	26	41.5	17	29	41.5
0.068 "	8.5	18.5	26.5	11	21	31.5	15	26	41.5	17	29	41.5	17	29	41.5	19	32	41.5
0.1 μF	10.5	20.5	26.5	11	22	41.5	17	29	41.5	17	29	41.5	19	32	41.5	20	39.5	41.5
0.15 "	11	21	26.5	15	26	41.5	19	32	41.5	20	39.5	41.5	20	39.5	41.5	24	45.5	41.5
0.22 "	13	24	31.5	17	29	41.5	20	39.5	41.5	24	45.5	41.5	24	45.5	41.5	27	37.5	56
0.33 "	15	26	31.5	19	32	41.5	24	45.5	41.5	27	37.5	56	27	37.5	56	33	48	56
0.47 "	17	29	41.5	20	39.5	41.5	27	37.5	56	27	37.5	56	33	48	56			
0.68 "	19	32	41.5	23	34	56	27	37.5	56									
1.0 μF	20	39.5	41.5	27	37.5	56												
1.5 "	24	45.5	41.5															
2.2 "	27	37.5	56															

* AC voltage: $f \leq 1000 \text{ Hz}$; $1.4 \times U_{\text{rms}} + \text{UDC} \leq U_r$

On ordering please state the required version and box size.

Versions and dimensional drawings see page 80.

Dims in mm.

Ionisation inception level in isolated cases may be lower than admissible rated AC voltage.

Rights reserved to amend design data without prior notification.

Permissible AC voltage in relation to frequency at 10° C internal temperature rise (general guide).

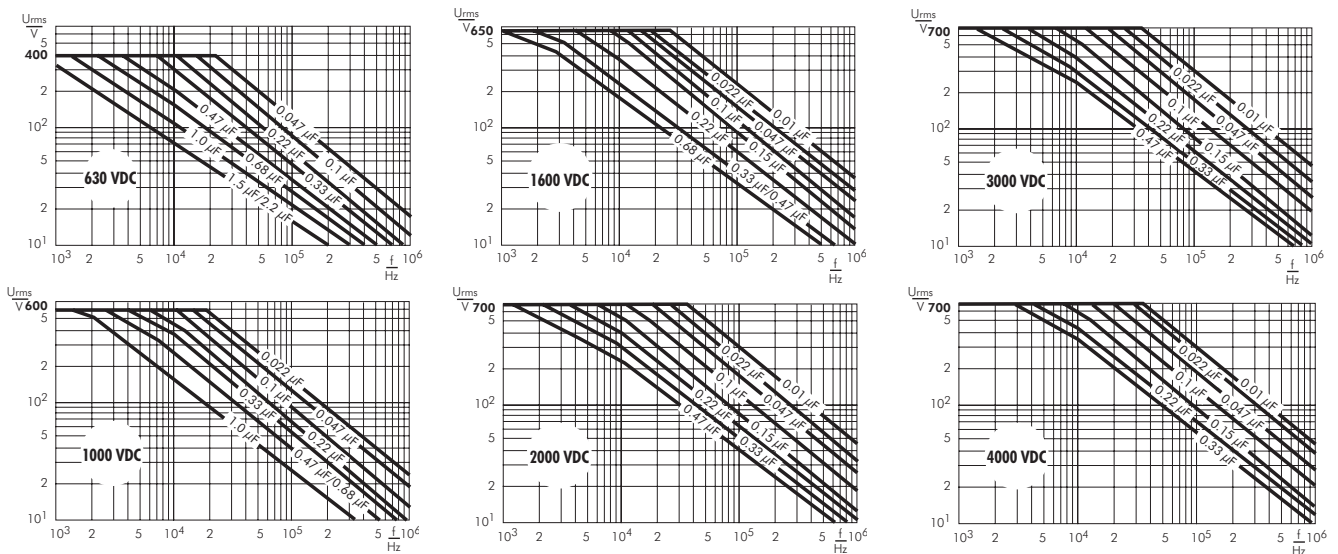

Versions of WIMA Snubber Capacitors

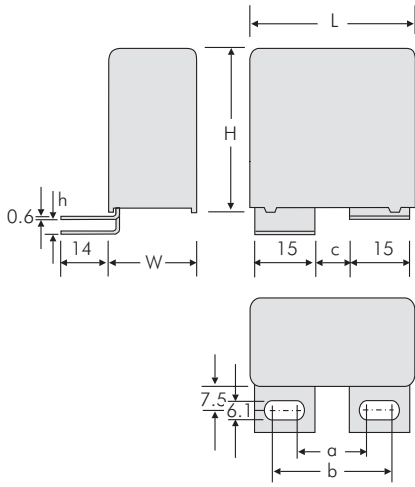

Version	L	a	b	c	h
A1	41.5	17.5	27.5	7.5	0
A1.5	41.5	17.5	27.5	7.5	3.5
A1	56	20	30	10	0
A1.4	56	20	30	10	3.5

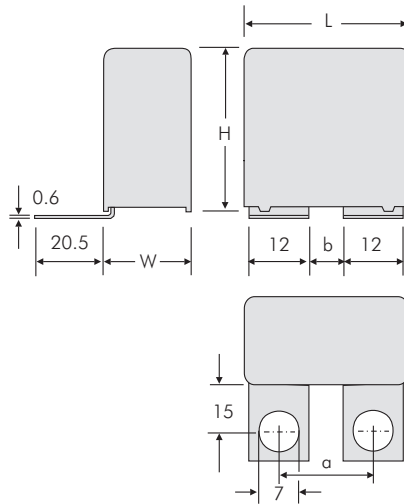

Version	L	a	b
A1.6	41.5	18	6
A1.6	56	29	17

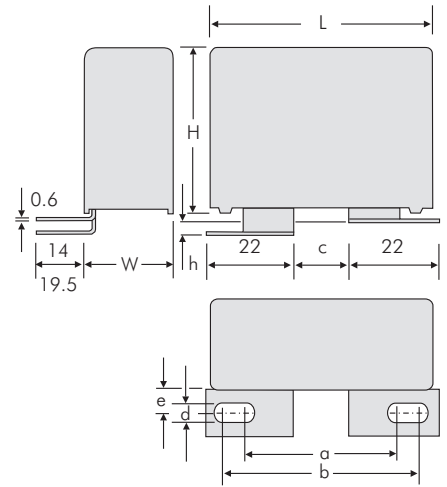

Version	L	a	b	c	d	e	h
A2	41.5	40.5	46.5	14.5	8.4	7.5	0
A2.1	56	39.5	45.5	13.5	8.4	7.5	0
A2.2	41.5	31	37	5	8.4	7.5	3.5
A2.3	41.5	31	37	5	8.4	13	3.5
A2.4	41.5	33.5	39.5	7.5	8.4	13	3.5
A2.5	41.5	29.5	39.5	5.5	6.1	7.5	3.5
A2.6	41.5	31.5	41.5	7.5	6.1	13	3.5
A2.7	56	39.5	45.5	13.5	8.4	7.5	3.5
A2.8	41.5	40.5	46.5	14.5	8.4	7.5	3.5

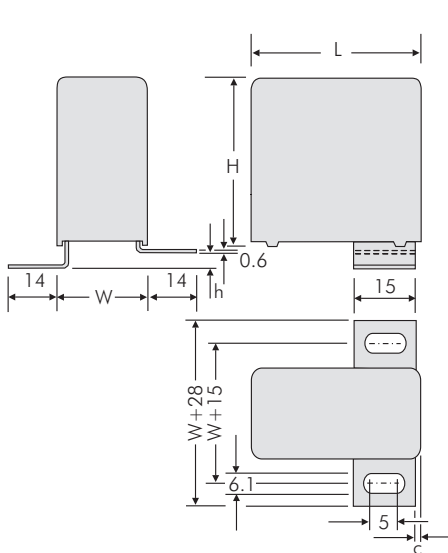

Version	L	c	h
A1.8	41.5	2	0
A1.2	41.5	2	3.5
A1.9	56	8	0
A1.1	56	8	3.5

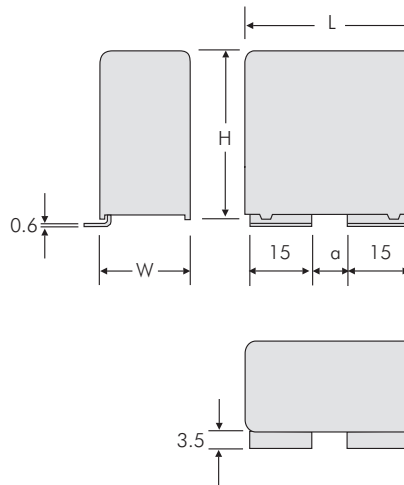

Version	L	a
A1.7	41.5	7.5
A1.7	56	10

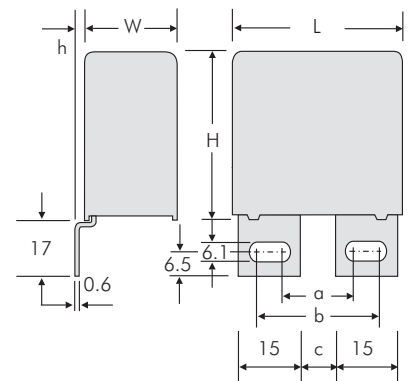

Version	L	a	b	c	h
A3	41.5	17.5	27.5	7.5	0
A3	56	20	30	10	0
A3.1	56	28	38	18	0
A3.5	41.5	17.5	27.5	7.5	3
A3.5	56	20	30	10	3
A3.10	56	28	38	18	3

Versions of WIMA Snubber Capacitors

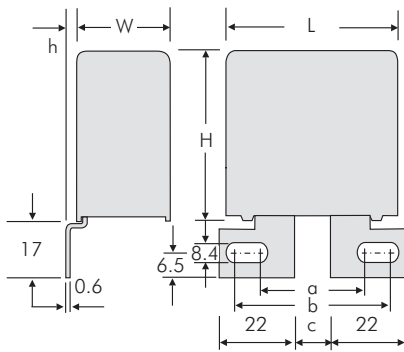

Version	L	a	b	c	h
A3.9	41.5	40.5	46.5	14.5	0
A3.2	56	39.5	45.5	13.5	0
A3.11	41.5	40.5	46.5	14.5	3
A3.3	56	39.5	45.5	13.5	3

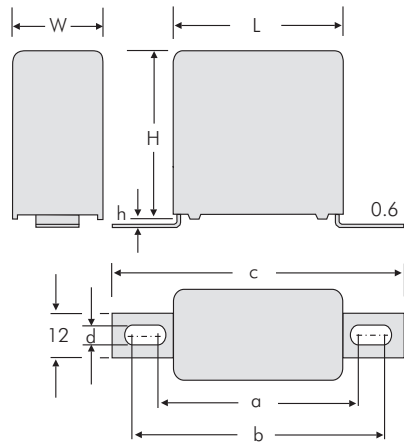

Version	L	a	b	c	d	h
A4.9	31.5 $W \geq 15$	44	47	57	4.5	2
A4.10	31.5 $W \geq 15$	43	59	69	6.1	2
A4.2	41.5 $W \geq 15$	54	57	67	4.5	2
A4	41.5 $W \geq 15$	53	69	79	6.1	2
A4.7	56	65	68	78	4.5	2
A4	56	64	80	90	6.1	2

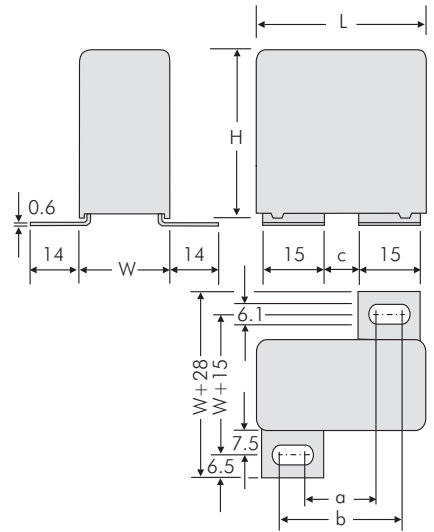

Version	L	a	b	c
A5	41.5	17.5	27.5	7.5
A5	56	20	30	10

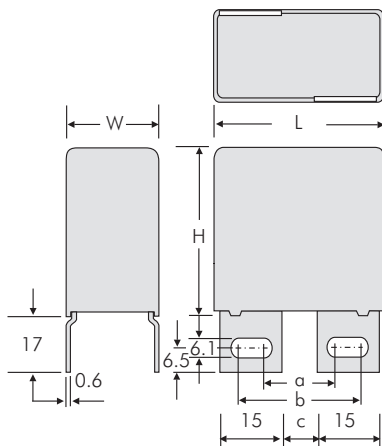

Version	L	a	b	c
A3.6	41.5	17.5	27.5	7.5
A3.7	56	20	30	10

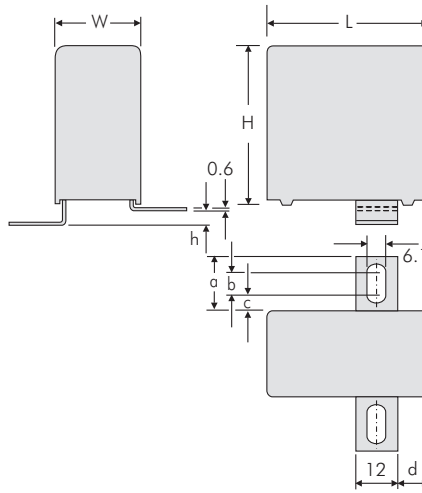

Version	L	a	b	c	d	h	W
A4.1	41.5	18	8	5	6	3.5	19
A4.3	31.5	19	8	6	1	3.5	19
A4.4	31.5	19	8	6	1	0	19
A4.5	41.5	18	8	5	6	0	19
A4.6	31.5	12.8	1.5	6.3	1	3.5	19
A4.8	31.5	12.8	1.5	6.3	1	0	19

4-lead version

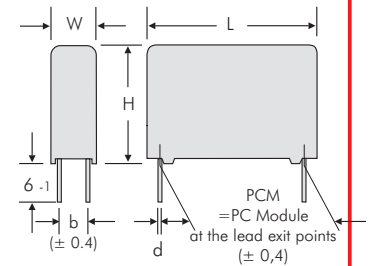

W	H	L	PCM	b	d
10.5	19	26.5	22.5	5	0.8
10.5	20.5	26.5	22.5	5	0.8
11	21	26.5	22.5	5	0.8
11	21	31.5	27.5	5	0.8
13	24	31.5	27.5	7.5	0.8
15	26	31.5	27.5	7.5	0.8
17	29	31.5	27.5	10	1
19	30	31.5	27.5	10	1
17	34.5	31.5	27.5	10	1
20	39.5	31.5	27.5	12.5	1
22	43.5	31.5	27.5	12.5	1
11	22	41.5	37.5	5	1
13	24	41.5	37.5	7.5	1
15	26	41.5	37.5	7.5	1
17	29	41.5	37.5	10	1
19	32	41.5	37.5	10	1
20	39.5	41.5	37.5	12.5	1
24	45.5	41.5	37.5	12.5	1
31	46	41.5	37.5	20	1
19	31	56	48.5	12.5	1
23	34	56	48.5	15	1
27	37.5	56	48.5	15	1
33	48	56	48.5	20	1
37	54	56	48.5	20	1

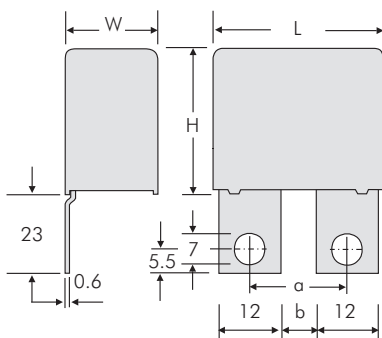

Version	L	a	b
A3.8	41.5	18	6

