

## IC-Fassung / IC-Leiste - Standardversion - Bauhöhe 4,2mm

IC Socket / IC-Strip - Standard Version - Height 4,2mm

### Technische Daten / Technical Data

Gehäuse/Abdeckung/Hebel	Thermoplastischer Kunststoff, nach UL94 V-0
Case/Cover/Actuator	Thermoplastic, rated UL94 V-0
Kontaktmaterial	Hülse: Messing gedreht Feder: 4-Lamellen-Clip, Beryllium-Kupfer
Contact Material	Sleeve: screw machined brass Clip: 4 Finger-Clip, Beryllium-Copper
Kontaktoberfläche	Lt. Oberflächenoptionen, über Ni (2 ... 3µm)
Contact Surface	Acc. to options (see below), over Ni (2 ... 3µm)
Lötbarkeit	IEC512-12A
Solderability	IEC512-12A
Durchgangswiderstand	< 10mΩ
Contact Resistance	< 10mΩ
Isolationswiderstand	> 10 <sup>10</sup> Ω
Insulation Resistance	> 10 <sup>10</sup> Ω
Spannungsfestigkeit	1000V <sub>RMS</sub>
Test Voltage	1000V <sub>RMS</sub>
Betriebsspannung	100V <sub>RMS</sub> / 150V <sub>DC</sub>
Operating Voltage	100V <sub>RMS</sub> / 150V <sub>DC</sub>
Nennstrom	1A
Current Rating	1A
Temperaturbereich	-25°C ... +85°C
Temperature Range	-25°C ... +85°C
Verarbeitung	Reflow-Lötverfahren; weitere Informationen in Kapitel T
Processing	Reflow-soldering, detailed information in ch. T

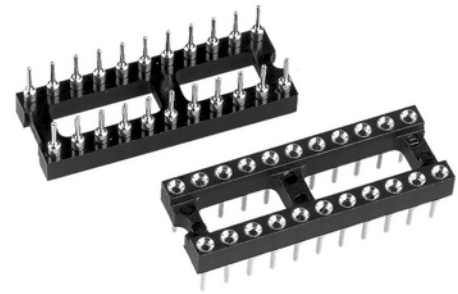

© W+P PRODUCTS

Für Rundstifte Ø 0,4 ... 0,56mm  
oder Vierkantstift 0,25 x 0,45mm.  
For round pin Ø 0,4 ... 0,56mm  
or square pin 0,25 x 0,45mm.

IC-Fassung Serie 169  
IC-Socket Series 169

IC-Leiste Serie 182  
IC-Strip Series 182

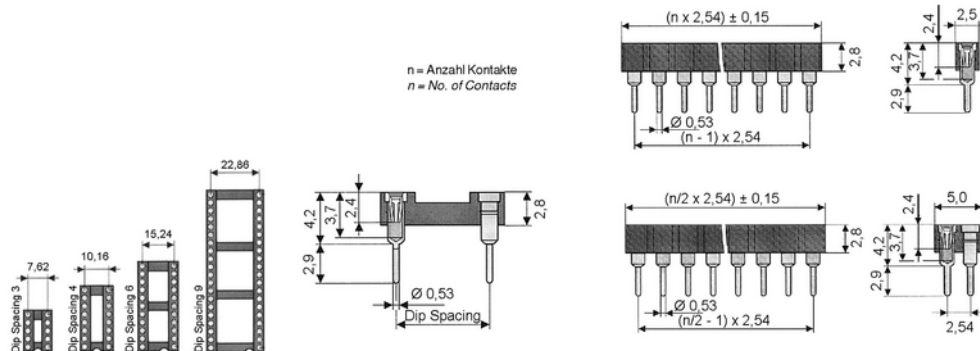

Series	Contacts *	DIP *	Sleeve Plating	Clip Plating *
<b>169</b>	<b>14</b>	<b>3</b>	<b>50</b>	<b>00</b>
169 IC-Fassung IC-Socket	08/14/16/18/ 20/22/24/28 22/24 24/28/32/40 50/52/64	3 7,62mm 4 10,16mm 6 15,24mm 9 22,86mm	50 Verzinkt (Standard) Tin plated (Standard)	00 Vergoldet (Standard) Gold plated (Standard) 10 Vergoldet 0,25µm 0,25µm gold plated 30 Vergoldet 0,75µm 0,75µm gold plated

Series	Contacts *	Rows *	Sleeve Plating	Clip Plating
<b>182</b>	<b>14</b>	<b>1</b>	<b>50</b>	<b>10</b>
182 IC-Leiste IC-Strip	01-64 Einreihig Single row 02-64 Zweireihig Double row	1 Einreihig Single row 2 Zweireihig Double row	50 Verzinkt (Standard) Tin plated (Standard)	10 Vergoldet 0,25µm 0,25µm gold plated

(\* Bestellbeispiel - Bitte durch Ihre Spezifikationen ersetzen.)

(\* Order example - To be replaced by your specifications.)

TEL.: +49 5223 98507-0  
FAX.: +49 5223 98507-50

# W+P PRODUCTS

E-MAIL: sales@wpro.com  
INTERNET: www.wpro.com

# Informationen zum Reflow-Lötverfahren

## Reflow-Soldering Information

### Reflow-Lötverfahren Reflow-Soldering

Bauteile sollten gemäß folgendem Temperatur-Profil in Anlehnung an die IPC/JEDEC J-STD-020C für bleifreies Löten im Reflowverfahren verarbeitet werden (Maximalwerte)

Profil Eigenschaft	Bleifreies Löten
Durchschnitts-Ramp-Up Rate ( $T_{S_{max}}$ to $T_p$ )	3°C / Sek. Max.
Vorheizen - Temperatur Min ( $T_{S_{min}}$ ) - Temperatur Max ( $T_{S_{max}}$ ) - Zeit ( $t_{S_{min}}$ auf $t_{S_{max}}$ )	150°C 200°C 60-180 Sekunden
Verbleiben oberhalb: - Temperatur ( $T_L$ ) - Zeit ( $t_L$ )	217°C 60-180 Sekunden
Peak/Klassifizierung Temperatur ( $T_p$ )	260°C +/- 5°C
Zeit innerhalb von 5°C um die Peak-Temperatur ( $t_p$ )	20-40 Sekunden
Ramp-Down Rate	6°C / Sekunde max.
Zeit von 25°C bis zur Peak-Temperatur	8 Minuten max.

Items should be soldered according to IPC/JEDEC J-STD-020C temperature-profile for leadfree reflow-soldering (maximum values):

Profile Feature	PB-Free assembly
Average Ramp-Up Rate ( $T_{S_{max}}$ to $T_p$ )	3°C / second max.
Preheat - Temperature Min ( $T_{S_{min}}$ ) - Temperature Max ( $T_{S_{max}}$ ) - Time ( $t_{S_{min}}$ auf $t_{S_{max}}$ )	150°C 200°C 60-180 seconds
Time maintained above: - Temperature ( $T_L$ ) - Time ( $t_L$ )	217°C 60-180 seconds
Peak/Classification Temperature ( $T_p$ )	260°C +/- 5°C
Time within 5°C of actual Peak-Temperature ( $t_p$ )	20-40 seconds
Ramp-Down Rate	6°C / second max.
Time 25°C to Peak Temperature	8 minutes max.

Empfohlenes Reflow-Lötprofil:

Recommended Reflow-Soldering profile:

