

## Wirewound Rheostat/Potentiometer



### FEATURES

- 12 W at 25 °C
- CCTU 05-03B (PA9)
- Vitreous style
- Compliant to RoHS directive 2002/95/EC



### DIMENSIONS in millimeters

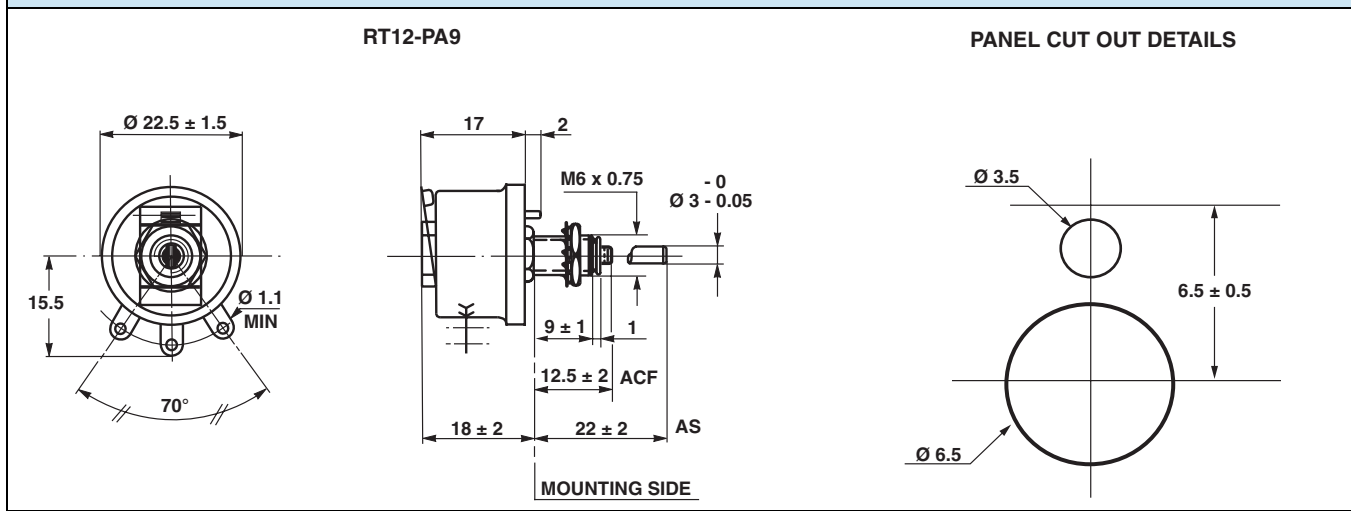

### MECHANICAL SPECIFICATIONS

Mechanical Protection	Vitreous
Mechanical Travel	290° + 15° - 10°
Operating Torque	1 Ncm to 10 Ncm
End Stop Torque	25 Ncm
Unit Weight	18.3 g

### ENVIRONMENTAL SPECIFICATIONS

Temperature Range	- 55 °C + 320 °C
Climatic Category	CCTU 454 CEI 55/200/56

ELECTRICAL SPECIFICATIONS	
Ohmic Range	1 Ω to 2.2 kΩ
Tolerance Standard	± 10 %
Power Rating	12 W at 25 °C
Variation Law	Linear
Limiting Element Voltage	300 V
Dielectric Strength	1000 V <sub>RMS</sub>
Insulation Resistance	10 <sup>3</sup> MΩ (500 V <sub>CC</sub> )

### LOCKING DEVICE

The spindle locking device can be fitted only to special units equipped with a slotted bushing.  
Order reference: B

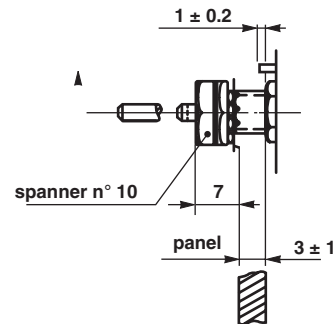

SPINDLES			
Ø mm	DISTANCE TO MOUNTING PLATE mm	SCREW DRIVER SLOT	CODE
3	12.5	With	ACF
3	22	Without	AS

### Note

- For any special requirement on request: spindle flats, etc. Please supply detailed drawing.

PARTICULAR CHARACTERISTICS		
NOMINAL RESISTANCE $\Omega$	MAX. SERVICE VOLTAGE V	MAX. CURRENT THROUGH WIPER mA
1	3.46	3460
1.5	4.24	2830
2.2	5.14	2340
3.3	6.29	1910
4.7	7.51	1600
6.8	9.03	1330
10	11	1100
15	13.4	900
22	16.3	740
33	19.9	603
47	23.7	505
68	28.6	420
100	34.6	346
150	42.4	283
220	51.4	234
330	62.9	191
470	75.1	160
680	90.3	133
1K	110	110
1.5K	134	90
2.2K	163	74

COMMAND KNOB: 20JF (OPTION)

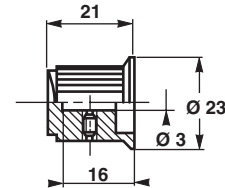

DIAL: CG45 (OPTION)

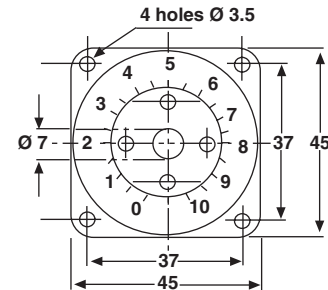

**MARKING**

Vishay Sfernice trademark, series, style, ohmic value (in  $\Omega$  or  $k\Omega$ ), tolerance (in %), maximum current in A, manufacturing date

ORDERING INFORMATION						
RT	012	AS	1501	K	B	XXX
MODEL	STYLE	SPINDLE	OHMIC VALUE	TOLERANCE	PACKAGING	SPECIAL DESIGN

GLOBAL PART NUMBER INFORMATION								
<div style="display: flex; justify-content: space-around; font-weight: bold; font-size: 1.2em;"> <span>R</span> <span>T</span> <span>0</span> <span>1</span> <span>2</span> <span>A</span> <span>S</span> <span>4</span> <span>7</span> <span>0</span> <span>1</span> <span>K</span> <span>B</span> </div>								
GLOBAL MODEL	SIZE	LOCKING DEVICE (OPT.)	WINDING (OPT.)	COMMAND SHAFT	OHMIC VALUE	TOLERANCE	PACKAGING	SPECIAL
RT	012	D	BXXX or BXXXX As applicable xxx(x) = Internal number	AS = Standard (Diam: 3 mm) ACF	The three first digits are significant figures and the last digit specifies the number of zeros to follow. R designates decimal point.  2002 = 20 k $\Omega$ 4701 = 4.7 k $\Omega$ 48R0 = 48 $\Omega$ 0R01 = 0.01 $\Omega$	J = 5 % K = 10 %	B = Bulk BO10  No standard packaging: N = Bulk, qty. open	As applicable Ex = DXxx



## Disclaimer

ALL PRODUCT, PRODUCT SPECIFICATIONS AND DATA ARE SUBJECT TO CHANGE WITHOUT NOTICE TO IMPROVE RELIABILITY, FUNCTION OR DESIGN OR OTHERWISE.

Vishay Intertechnology, Inc., its affiliates, agents, and employees, and all persons acting on its or their behalf (collectively, "Vishay"), disclaim any and all liability for any errors, inaccuracies or incompleteness contained in any datasheet or in any other disclosure relating to any product.

Vishay makes no warranty, representation or guarantee regarding the suitability of the products for any particular purpose or the continuing production of any product. To the maximum extent permitted by applicable law, Vishay disclaims (i) any and all liability arising out of the application or use of any product, (ii) any and all liability, including without limitation special, consequential or incidental damages, and (iii) any and all implied warranties, including warranties of fitness for particular purpose, non-infringement and merchantability.

Statements regarding the suitability of products for certain types of applications are based on Vishay's knowledge of typical requirements that are often placed on Vishay products in generic applications. Such statements are not binding statements about the suitability of products for a particular application. It is the customer's responsibility to validate that a particular product with the properties described in the product specification is suitable for use in a particular application. Parameters provided in datasheets and/or specifications may vary in different applications and performance may vary over time. All operating parameters, including typical parameters, must be validated for each customer application by the customer's technical experts. Product specifications do not expand or otherwise modify Vishay's terms and conditions of purchase, including but not limited to the warranty expressed therein.

Except as expressly indicated in writing, Vishay products are not designed for use in medical, life-saving, or life-sustaining applications or for any other application in which the failure of the Vishay product could result in personal injury or death. Customers using or selling Vishay products not expressly indicated for use in such applications do so at their own risk and agree to fully indemnify and hold Vishay and its distributors harmless from and against any and all claims, liabilities, expenses and damages arising or resulting in connection with such use or sale, including attorneys fees, even if such claim alleges that Vishay or its distributor was negligent regarding the design or manufacture of the part. Please contact authorized Vishay personnel to obtain written terms and conditions regarding products designed for such applications.

No license, express or implied, by estoppel or otherwise, to any intellectual property rights is granted by this document or by any conduct of Vishay. Product names and markings noted herein may be trademarks of their respective owners.

## Material Category Policy

**Vishay Intertechnology, Inc. hereby certifies that all its products that are identified as RoHS-Compliant fulfill the definitions and restrictions defined under Directive 2011/65/EU of The European Parliament and of the Council of June 8, 2011 on the restriction of the use of certain hazardous substances in electrical and electronic equipment (EEE) - recast, unless otherwise specified as non-compliant.**

**Please note that some Vishay documentation may still make reference to RoHS Directive 2002/95/EC. We confirm that all the products identified as being compliant to Directive 2002/95/EC conform to Directive 2011/65/EU.**