

## Power Resistor for Mounting onto a Heatsink Thick Film Technology



### FEATURES

- 300 W at 85 °C bottom case temperature
- Wide resistance range: 0.3 Ω to 900 kΩ E24 series
- Non inductive
- Easy mounting
- Low thermal radiation of the case
- Compliant to RoHS directive 2002/95/EC

**RoHS**  
COMPLIANT

### DIMENSIONS in millimeters

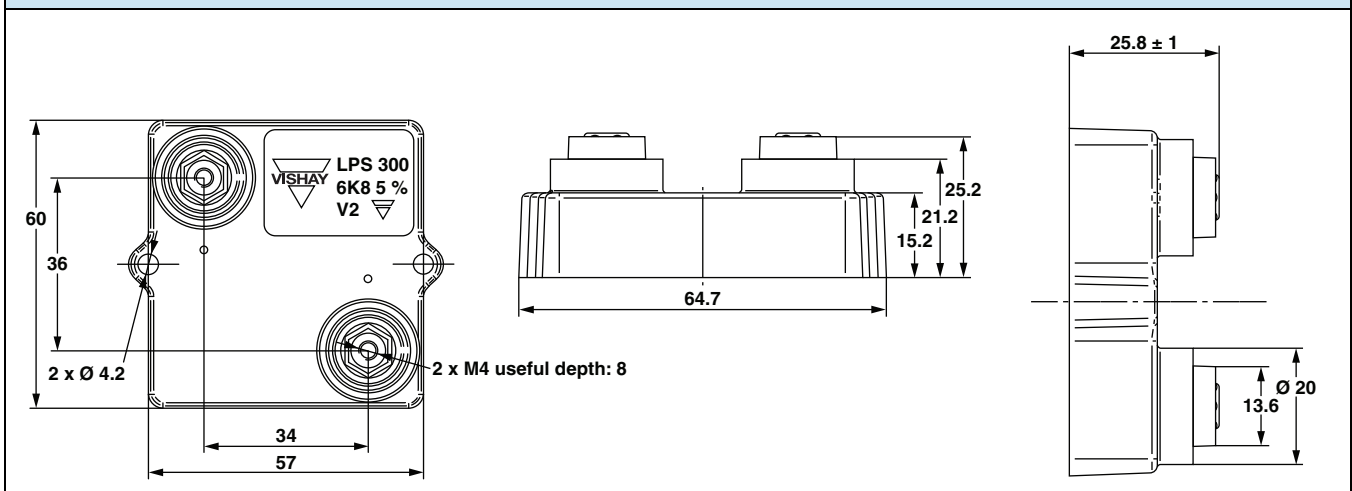

#### Note

- Tolerances unless stated: ± 0.2 mm

### MECHANICAL SPECIFICATIONS

<b>Mechanical Protection</b>	Insulated case UL 94 V-0
<b>Resistive Element</b>	Thick film
<b>Substrate</b>	Alumina
<b>End Connections</b>	Screws M4
<b>Tightening Torque</b>	
- On Connections	2 Nm
- On Heatsink	2 Nm
<b>Maximum Torque</b>	2.5 Nm
<b>Weight</b>	83 g ± 10 %

### ENVIRONMENTAL SPECIFICATIONS

<b>Temperature Range</b>	- 55 °C to 120 °C
<b>Climatic Category</b>	55/120/56

### ELECTRICAL SPECIFICATIONS

<b>Resistance Range</b>	0.3 Ω to 900 kΩ
<b>Tolerances (Standard)</b>	± 1 % to ± 10 %
<b>Power Rating and Thermal Resistance</b>	300 W at + 85 °C bottom case temperature $R_{TH(j-c)}$ : 0.112 °C/W
<b>Temperature Coefficient</b>	$R \leq 1 U$ : ± 500 ppm/°C $1 U < R \leq 10 U$ : ± 300 ppm/°C $10 U < R$ : ± 150 ppm/°C
<b>- 55 °C/120 °C IEC 60115-1 Standard</b>	
<b>Limiting Element Voltage <math>U_L</math></b>	5 kV
<b>Dielectric Strength IEC 60115-1, 1 min, 10 mA max.</b>	7 kV <sub>RMS</sub> or 12 kV <sub>RMS</sub>
<b>Insulation Resistance</b>	≥ 10 <sup>4</sup> MΩ
<b>Inductance</b>	≤ 0.1 μH
<b>Critical Resistance</b>	83.33 kΩ



PERFORMANCE		
TESTS	CONDITIONS	REQUIREMENTS
Momentary Overload	IEC 60115-1 4 x P <sub>r</sub> /10 s U <sub>max.</sub> ≤ U <sub>L</sub> = 5000 V	± (0.25 % + 0.05 Ω)
Rapid Temperature Change	IEC 60115-1/IEC 60068-2-14 Test Na 5 cycles - 55 °C to + 120 °C	± (0.5 % + 0.05 Ω)
Load Life	IEC 60115-1 1000 h (90/30) P <sub>r</sub> at 85 °C	± (0.5 % + 0.05 Ω)
Humidity (Steady State)	IEC 60115-1 56 days RH 95 %/40 °C	± (0.5 % + 0.05 Ω)
Vibration	MIL STD 202 Method 204 Cond. D (10 g; 5/500 Hz)	± (0.25 % + 0.05 Ω)
Climatic Sequence	IEC 60115-1 (55/120/56)	± (1 % + 0.05 Ω)

## RECOMMENDATIONS FOR MOUNTING ONTO A HEATSINK

- Surfaces in contact must be carefully cleaned.
- The heatsink must have an acceptable flatness: From 0.05 mm to 0.1 mm/100 mm.
- Roughness of the heatsink must be around 6.3 μm. In order to improve thermal conductivity, surfaces in contact (alumina, heatsink) should be coated with a silicone grease (type SI 340 from Rhône-Poulenc or Dow 340 from Dow Corning) or a thermal film (type Q Pad II) easier and faster to install than the grease.
- The fastening of the resistor to the heatsink is under pressure control of two screws tightened at 2 Nm for full power availability.

Tightening Torque on Heatsink	LPS 300
	2 Nm

- The following accessories are supplied with each product: 2 screws CHC M4 x 25 class 8.8 and 2 M4 contact lock washers for heatsink mounting,  
2 screws TH M4 x 6/6 and 2 M4 contact lock washers for connections. 2 off CHC M4 x 16/16 class 8.

## CHOICE OF THE HEATSINK

The user must choose the heatsink according to the working conditions of the component (power, room temperature). Maximum working temperature must not exceed 120 °C. The dissipated power is simply calculated by the following ratio:

$$P = \frac{\Delta T}{[R_{TH(j-c)} + R_{TH(c-a)}]}$$

- P: Expressed in W
- ΔT: Difference between maximum working temperature and room temperature
- R<sub>TH(j-c)</sub>: Thermal resistance value measured between resistive layer and outer side of the resistor. It is the thermal resistance of the component: (see specifications environmental paragraph).
- R<sub>TH(c-a)</sub>: Thermal resistance value measured between outer side of the resistor and room temperature. It is the thermal resistance of the thermal interface, the heatsink (type, shape) and the quality of the fastening device.

### Example:

R<sub>TH(c-a)</sub> for LPS 300 power dissipation 180 W at + 50 °C room temperature.

$$\Delta T \leq 120 \text{ °C} - 50 \text{ °C} = 70 \text{ °C}$$

$$R_{TH(j-c)} + R_{TH(c-a)} = \frac{\Delta T}{P} = \frac{70}{180} = 0.388 \text{ °C/W}$$

$$R_{TH(j-c)} = 0.112 \text{ °C/W}$$

$$R_{TH(c-a)} = 0.388 \text{ °C/W} - 0.112 \text{ °C/W} = 0.276 \text{ °C/W}$$

**OVERLOADS**

In any case the applied voltage must be lower than  $U_L = 5000$  V.

**Short time overload:**  $4 \times P_n / 10$  s

**Accidental overload:** The values indicated on the following graph are applicable to resistors in air or mounted onto a heatsink.

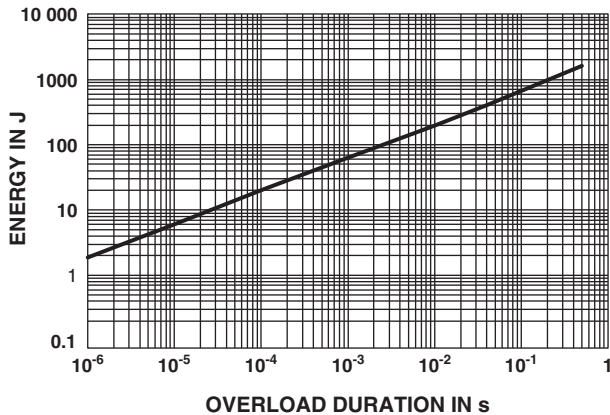
**ENERGY CURVE**

**POWER RATING**

The temperature of the case should be maintained within the limits specified in the following figure.

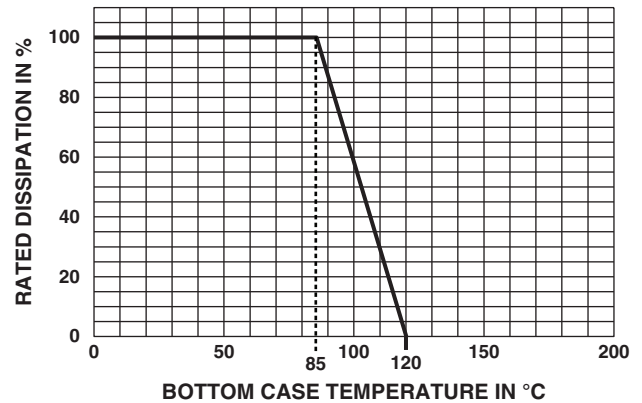
To optimize the thermal conduction, contacting surfaces should be coated with silicone grease or thermal film, and heatsink mounting screws tightened to 2 Nm.

**MARKING**

Series, style, ohmic value (in  $\Omega$ ), tolerance (in %), manufacturing date, Vishay Sfernice trademark.

**PACKAGING**

Box of 15 units

**ORDERING INFORMATION**

<b>LPS</b>	<b>300</b>	<b>100 k<math>\Omega</math></b>	<b><math>\pm 1</math> %</b>	<b>xxx</b>	<b>BO15</b>	<b>e</b>
MODEL	STYLE	RESISTANCE VALUE	TOLERANCE	CUSTOM DESIGN Optional on request: Special TCR, shape etc.	PACKAGING	LEAD (Pb)-FREE
			$\pm 1$ % $\pm 2$ % $\pm 5$ % $\pm 10$ %			

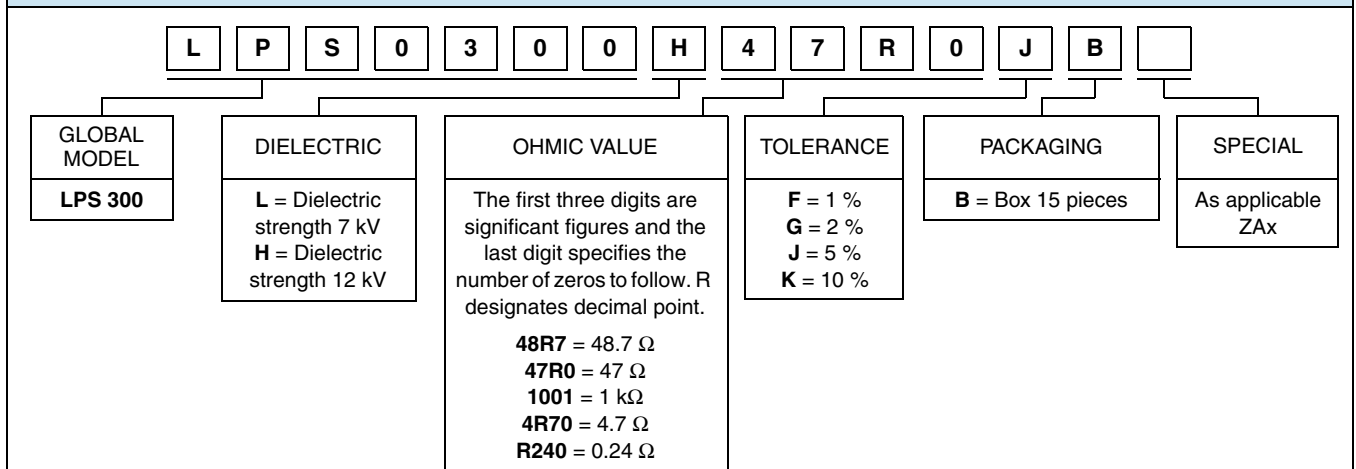
**GLOBAL PART NUMBER INFORMATION**



## Disclaimer

ALL PRODUCT, PRODUCT SPECIFICATIONS AND DATA ARE SUBJECT TO CHANGE WITHOUT NOTICE TO IMPROVE RELIABILITY, FUNCTION OR DESIGN OR OTHERWISE.

Vishay Intertechnology, Inc., its affiliates, agents, and employees, and all persons acting on its or their behalf (collectively, "Vishay"), disclaim any and all liability for any errors, inaccuracies or incompleteness contained in any datasheet or in any other disclosure relating to any product.

Vishay makes no warranty, representation or guarantee regarding the suitability of the products for any particular purpose or the continuing production of any product. To the maximum extent permitted by applicable law, Vishay disclaims (i) any and all liability arising out of the application or use of any product, (ii) any and all liability, including without limitation special, consequential or incidental damages, and (iii) any and all implied warranties, including warranties of fitness for particular purpose, non-infringement and merchantability.

Statements regarding the suitability of products for certain types of applications are based on Vishay's knowledge of typical requirements that are often placed on Vishay products in generic applications. Such statements are not binding statements about the suitability of products for a particular application. It is the customer's responsibility to validate that a particular product with the properties described in the product specification is suitable for use in a particular application. Parameters provided in datasheets and/or specifications may vary in different applications and performance may vary over time. All operating parameters, including typical parameters, must be validated for each customer application by the customer's technical experts. Product specifications do not expand or otherwise modify Vishay's terms and conditions of purchase, including but not limited to the warranty expressed therein.

Except as expressly indicated in writing, Vishay products are not designed for use in medical, life-saving, or life-sustaining applications or for any other application in which the failure of the Vishay product could result in personal injury or death. Customers using or selling Vishay products not expressly indicated for use in such applications do so at their own risk and agree to fully indemnify and hold Vishay and its distributors harmless from and against any and all claims, liabilities, expenses and damages arising or resulting in connection with such use or sale, including attorneys fees, even if such claim alleges that Vishay or its distributor was negligent regarding the design or manufacture of the part. Please contact authorized Vishay personnel to obtain written terms and conditions regarding products designed for such applications.

No license, express or implied, by estoppel or otherwise, to any intellectual property rights is granted by this document or by any conduct of Vishay. Product names and markings noted herein may be trademarks of their respective owners.

## Material Category Policy

**Vishay Intertechnology, Inc. hereby certifies that all its products that are identified as RoHS-Compliant fulfill the definitions and restrictions defined under Directive 2011/65/EU of The European Parliament and of the Council of June 8, 2011 on the restriction of the use of certain hazardous substances in electrical and electronic equipment (EEE) - recast, unless otherwise specified as non-compliant.**

**Please note that some Vishay documentation may still make reference to RoHS Directive 2002/95/EC. We confirm that all the products identified as being compliant to Directive 2002/95/EC conform to Directive 2011/65/EU.**