

Wirewound and Fusible Wirewound Resistors in Ceramic Case

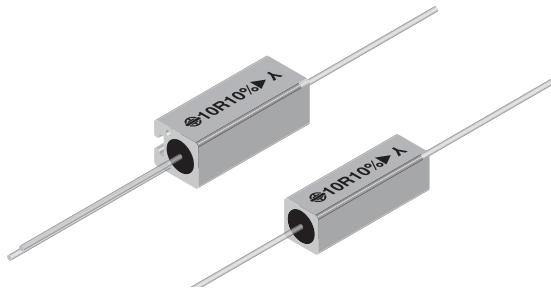

FEATURES

- Fiberglass core, ceramic case
- Fireproof inorganic construction
- Axial or radial leaded
- Fusing styles available as style KKE.. Si
- Pure tin plating provides compatibility with lead (Pb)-free and lead containing soldering processes
- Material categorization: for definitions of compliance please see www.vishay.com/doc?99912



RoHS
COMPLIANT
HALOGEN
FREE
GREEN
(5-2008)

STANDARD ELECTRICAL SPECIFICATIONS						
GLOBAL MODEL	POWER RATING W $P_{70^{\circ}\text{C}}$	LIMITING VOLTAGE V	RESISTANCE RANGE ⁽¹⁾ Ω TCR +400 \pm 50 ppm/K	RESISTANCE RANGE ⁽¹⁾ Ω TCR +0 \pm 40 ppm/K	RESISTANCE RANGE ⁽¹⁾ Ω TCR +0 \pm 10 ppm/K	TOLERANCE \pm %
KKA4	4	125	0.056 to 0.20	0.22 to 300	330 to 9.1K	10
	4		0.10 to 0.20	0.22 to 300	330 to 9.1K	5
KKA5	5	185	0.075 to 0.30	0.33 to 470	510 to 15K	10
	5		0.15 to 0.30	0.33 to 470	510 to 15K	5
KKA7	7	250	0.11 to 0.68	0.75 to 910	1 to 33K	10
	7		0.33 to 0.68	0.75 to 910	1 to 33K	5
KKA9	9	250	0.11 to 0.68	0.75 to 910	1K to 33K	10
	9		0.33 to 0.68	0.75 to 910	1K to 33K	5
KKA11	11	350	0.15 to 1.0	1.1 to 1.3 K	1.5K to 47K	10
	11		0.51 to 1.0	1.1 to 1.3 K	1.5K to 47K	5
KKA17	17	500	0.27 to 1.6	1.8 to 2.4K	2.7K to 82K	10
	17		0.91 to 1.6	1.8 to 2.4K	2.7K to 82K	5
KKE4	4	125	0.056 to 0.20	0.22 to 300	330 to 9.1K	10
	4		0.10 to 0.20	0.22 to 300	330 to 9.1K	5
KKE7	7	250	0.075 to 0.30	0.33 to 470	510 to 15K	10
	7		0.15 to 0.30	0.33 to 470	510 to 15K	5
KKE9	9	250	0.11 to 0.68	0.75 to 910	1K to 33K	10
	9		0.33 to 0.68	0.75 to 910	1K to 33K	5
KKE11	11	350	0.15 to 1.0	1.1 to 1.3 K	1.5K to 47K	10
	11		0.51 to 1.0	1.1 to 1.3 K	1.5K to 47K	5
KKE17	17	500	0.27 to 1.6	1.8 to 2.4K	2.7K to 82K	10
	17		0.91 to 1.6	1.8 to 2.4K	2.7K to 82K	5
KKE7 Si ⁽²⁾	4	165	0.075 to 0.13	-	-	10
	4		-	0.15 to 12K	-	5
KKE9 Si ⁽²⁾	5.5	250	0.11 to 0.30	-	-	10
	5.5		-	0.33 to 33K	-	5
KKE11 Si ⁽²⁾	7	350	0.28 to 0.47	-	-	10
	7		-	0.51 to 47K	-	5

Notes

⁽¹⁾ Resistance value to be selected for \pm 10 % tolerance from E12 and for \pm 5 % from E24.

⁽²⁾ Power rating at $P_{40^{\circ}\text{C}}$.



PART NUMBER AND PRODUCT DESCRIPTION																
Part Number: KKA040B1009KG1000																
K	K	A	0	4	0	B	1	0	0	9	K	G	1	0	0	0
MODEL	VARIANT	TCR/MATERIAL	VALUE	TOLERANCE CODE	PACKAGING CODE	SPECIAL										
KKA04 = KKA4 KKA05 = KKA5 KKA07 = KKA7 KKA09 = KKA9 KKA11 = KKA11 KKA17 = KKA17 KKE04 = KKE4 KKE07 = KKE7 KKE09 = KKE9 KKE11 = KKE11 KKE17 = KKE17	0 = Neutral L = Si	0 = SWI per BV A = 400 ± 50 ppm/K B = 0 ± 40 ppm/K C = 0 ± 10 ppm/K D = +200... +1200 ppm/K	3 digit value 1 digit multiplier MULTIPLIER F = 10^{-4} 7 = 10^{-3} 8 = 10^{-2} 9 = 10^{-1} 0 = 10^0 1 = 10^1 2 = 10^2	J = $\pm 5.0\%$ K = $\pm 10.0\%$	(See Packaging table)	The 5 digit BV number will be encoded using a 36 character code. This code contains numbers 0 to 9 and letters A to Z (36 characters total) and allows to encode at least 46 655 five digit BV numbers. 000 = Standard										
Product Description: KKA4 10R 10% 0+40 -80 R1																
KKA4	10R	10%	0 ± 40	R1												
MODEL (1)	VALUE (1)	TOLERANCE CODE (1)	TCR/MATERIAL (1)	PACKAGING DESCRIPTION (2)												

Notes

- (1) See "Part Number" above.
- (2) See "Packaging Table".

PACKAGING TABLE						
MODEL	REEL (3)			LOOSE		
	PIECES	PACKAGING CODE	PACKAGING DESCRIPTION	PIECES	PACKAGING CODE	PACKAGING DESCRIPTION
KKA4	1000	G1	R1	200	LJ	LJ
KKA5	1000	G1	R1	200	LJ	LJ
KKA7				200	LJ	LJ
KKA9				100	LA	LA
KKA11				100	LA	LA
KKA17				100	LA	LA
KKE4				200	LJ	LJ
KKE7				200	LJ	LJ
KKE9				200	LJ	LJ
KKE11				200	LJ	LJ
KKE17				100	LA	LA
KKE7 Si				200	LJ	LJ
KKE9 Si				200	LJ	LJ
KKE11 Si				200	LJ	LJ

Note

- (3) Tape length for KKA4 and KKA5 = 80 mm.

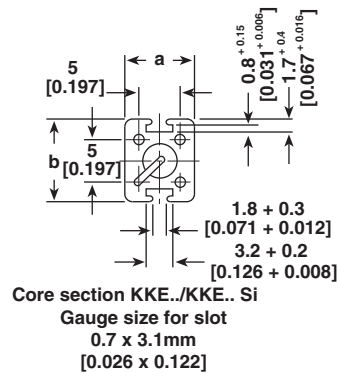
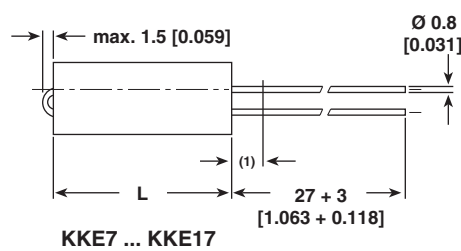
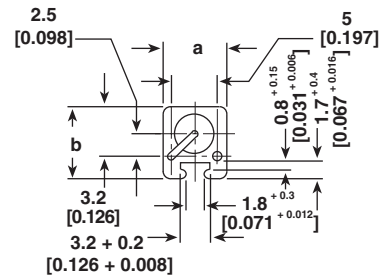
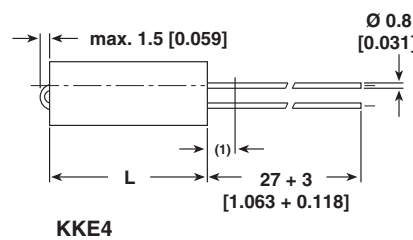
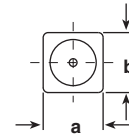
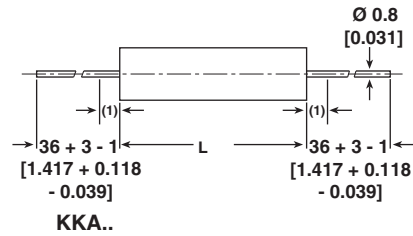
DIMENSIONS in millimeters [inches]

MODEL	a	b	L	MASS (g)
KKA4	6.4 [0.256]	6.4 [0.256]	20 [0.787]	1.8
KKA5	6.4 [0.256]	6.4 [0.256]	25 [0.984]	5.5
KKA7	6.4 [0.256]	6.4 [0.256]	38 [1.496]	3.2
KKA9	9 [0.354]	9 [0.354]	38 [1.496]	7
KKA11	9 [0.354]	9 [0.354]	50 [1.969]	9
KKA17	9 [0.354]	9 [0.354]	75 [2.953]	13
KKE4	7 [0.276]	7.8 [0.307]	19.5 [0.768]	2
KKE7	9 [0.354]	10.5 [0.413]	25 [0.984]	4
KKE9	9 [0.354]	10.5 [0.413]	38 [1.496]	7.5
KKE11	9 [0.354]	10.5 [0.413]	50 [1.969]	9.5
KKE17	9 [0.354]	10.5 [0.413]	75 [2.953]	13.5

Note

(1) In this section confined solderability 6 mm [0.157].

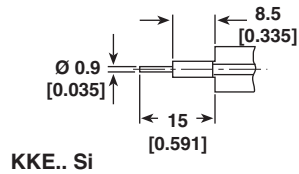
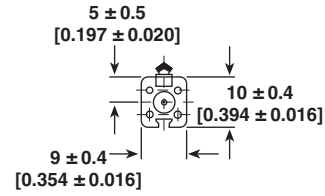
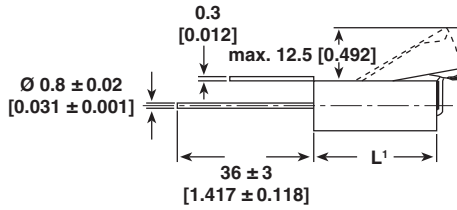
DIMENSIONS in millimeters [inches] (continued)

KKE.. Si

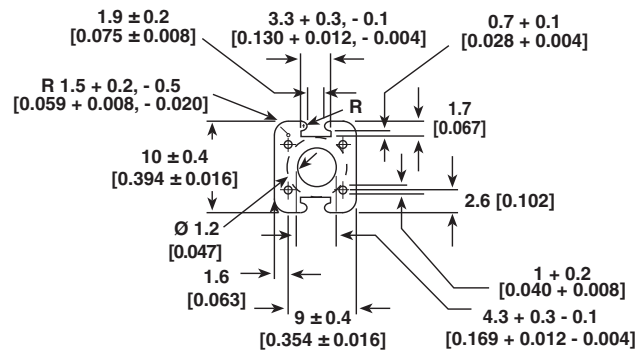

Profile dimensions

MODEL	a	b	L	MASS (g)
KKE7 Si	9 [0.354]	10.5 [0.413]	25 [0.984]	5.5
KKE9 Si	9 [0.354]	10.5 [0.413]	38 [1.496]	8
KKE11 Si	9 [0.354]	10.5 [0.413]	50 [1.969]	9.8

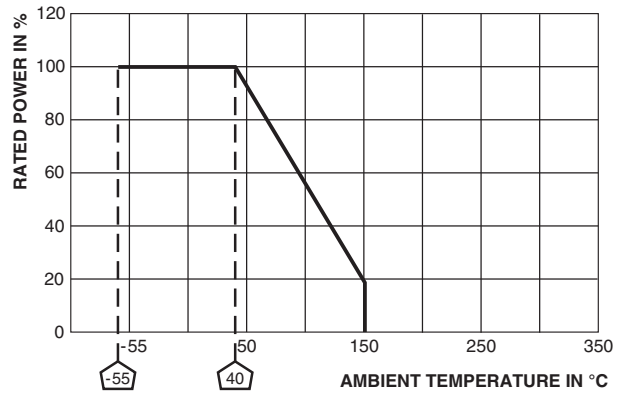
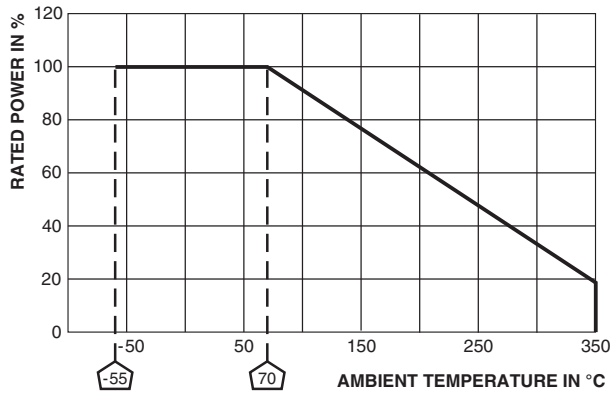

Derating KKA, KKE

Derating KKE.. Si

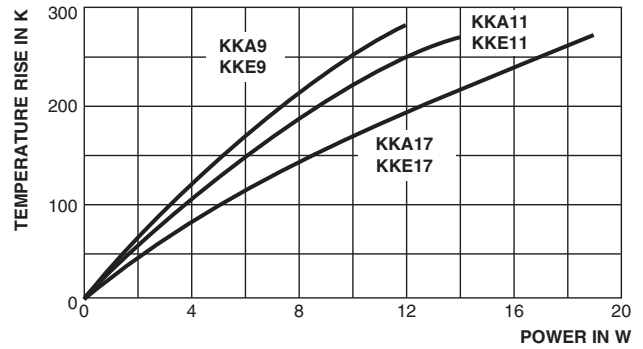
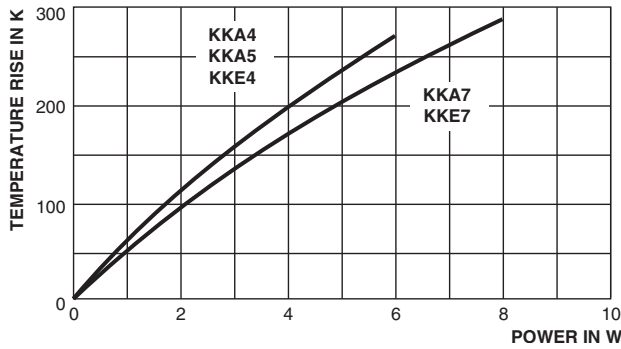

Temperature Rise

Temperature Rise

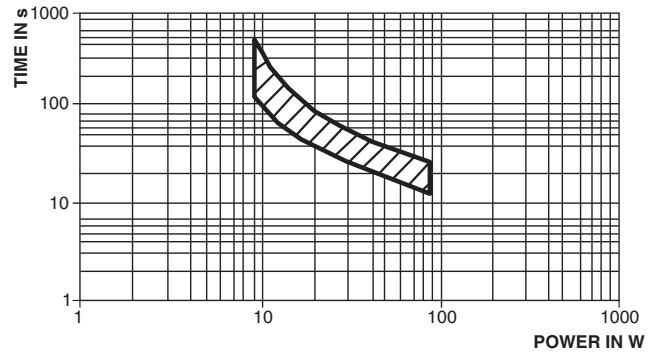
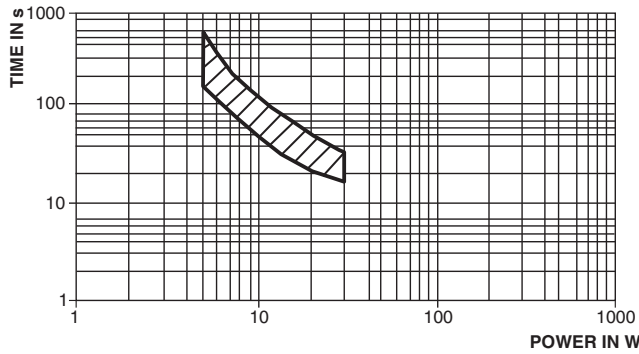

Fusing Characteristics KKE7 Si

Fusing Characteristics KKE11 Si

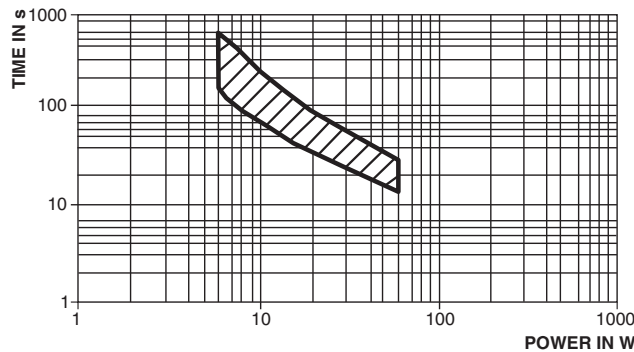

Fusing Characteristics KKE9 Si



PERFORMANCE	
TEST	TEST RESULTS
Load Life P_{70} , 70 °C, 1000 h	$\leq \pm 3.0 \% \Delta R$ average
Climatic Sequence IEC 60115-1 4.23	$\leq \pm 2.0 \% \Delta R$
Damp Heat, Steady State (40 ± 2) °C, 56 days, (93 ± 3) % RH	$\leq \pm 2.0 \% \Delta R$
Resistance to Solder Heat (260 ± 5) °C, (10 ± 1) s	$\leq \pm 0.2 \% \Delta R$ typical



Disclaimer

ALL PRODUCT, PRODUCT SPECIFICATIONS AND DATA ARE SUBJECT TO CHANGE WITHOUT NOTICE TO IMPROVE RELIABILITY, FUNCTION OR DESIGN OR OTHERWISE.

Vishay Intertechnology, Inc., its affiliates, agents, and employees, and all persons acting on its or their behalf (collectively, "Vishay"), disclaim any and all liability for any errors, inaccuracies or incompleteness contained in any datasheet or in any other disclosure relating to any product.

Vishay makes no warranty, representation or guarantee regarding the suitability of the products for any particular purpose or the continuing production of any product. To the maximum extent permitted by applicable law, Vishay disclaims (i) any and all liability arising out of the application or use of any product, (ii) any and all liability, including without limitation special, consequential or incidental damages, and (iii) any and all implied warranties, including warranties of fitness for particular purpose, non-infringement and merchantability.

Statements regarding the suitability of products for certain types of applications are based on Vishay's knowledge of typical requirements that are often placed on Vishay products in generic applications. Such statements are not binding statements about the suitability of products for a particular application. It is the customer's responsibility to validate that a particular product with the properties described in the product specification is suitable for use in a particular application. Parameters provided in datasheets and/or specifications may vary in different applications and performance may vary over time. All operating parameters, including typical parameters, must be validated for each customer application by the customer's technical experts. Product specifications do not expand or otherwise modify Vishay's terms and conditions of purchase, including but not limited to the warranty expressed therein.

Except as expressly indicated in writing, Vishay products are not designed for use in medical, life-saving, or life-sustaining applications or for any other application in which the failure of the Vishay product could result in personal injury or death. Customers using or selling Vishay products not expressly indicated for use in such applications do so at their own risk. Please contact authorized Vishay personnel to obtain written terms and conditions regarding products designed for such applications.

No license, express or implied, by estoppel or otherwise, to any intellectual property rights is granted by this document or by any conduct of Vishay. Product names and markings noted herein may be trademarks of their respective owners.

Material Category Policy

Vishay Intertechnology, Inc. hereby certifies that all its products that are identified as RoHS-Compliant fulfill the definitions and restrictions defined under Directive 2011/65/EU of The European Parliament and of the Council of June 8, 2011 on the restriction of the use of certain hazardous substances in electrical and electronic equipment (EEE) - recast, unless otherwise specified as non-compliant.

Please note that some Vishay documentation may still make reference to RoHS Directive 2002/95/EC. We confirm that all the products identified as being compliant to Directive 2002/95/EC conform to Directive 2011/65/EU.

Vishay Intertechnology, Inc. hereby certifies that all its products that are identified as Halogen-Free follow Halogen-Free requirements as per JEDEC JS709A standards. Please note that some Vishay documentation may still make reference to the IEC 61249-2-21 definition. We confirm that all the products identified as being compliant to IEC 61249-2-21 conform to JEDEC JS709A standards.