

"Half-Bridge" IGBT INT-A-PAK (Standard Speed IGBT), 200 A



INT-A-PAK

FEATURES

- Generation 4 IGBT technology
- Standard: Optimized for hard switching speed DC to 1 kHz
- Very low conduction losses
- Industry standard package
- UL approved file E78996 
- Compliant to RoHS directive 2002/95/EC
- Designed and qualified for industrial level

RoHS
COMPLIANT

BENEFITS

- Increased operating efficiency
- Direct mounting to heatsink
- Performance optimized as output inverter stage for TIG welding machines

PRODUCT SUMMARY

V_{CES}	600 V
I_C DC	480 A
$V_{CE(on)}$ at 200 A, 25 °C	1.13 V

ABSOLUTE MAXIMUM RATINGS

PARAMETER	SYMBOL	TEST CONDITIONS	MAX.	UNITS
Collector to emitter voltage	V_{CES}		600	V
Continuous collector current	I_C	$T_C = 25\text{ °C}$	480	A
		$T_C = 116\text{ °C}$	200	
Pulsed collector current	I_{CM}		800	
Peak switching current	I_{LM}		800	
Gate to emitter voltage	V_{GE}		± 20	V
RMS isolation voltage	V_{ISOL}	Any terminal to case, t = 1 minute	2500	
Maximum power dissipation	P_D	$T_C = 25\text{ °C}$	830	W
		$T_C = 85\text{ °C}$	430	

ELECTRICAL SPECIFICATIONS ($T_J = 25\text{ °C}$ unless otherwise specified)

PARAMETER	SYMBOL	TEST CONDITIONS	MIN.	TYP.	MAX.	UNITS
Collector to emitter breakdown voltage	$V_{BR(CES)}$	$V_{GE} = 0\text{ V}, I_C = 1\text{ mA}$	600	-	-	V
Collector to emitter voltage	$V_{CE(on)}$	$V_{GE} = 15\text{ V}, I_C = 200\text{ A}$	-	1.13	1.21	
		$V_{GE} = 15\text{ V}, I_C = 200\text{ A}, T_J = 125\text{ °C}$	-	1.08	1.18	
Gate threshold voltage	$V_{GE(th)}$	$I_C = 0.25\text{ mA}$	3	4.5	6	
Collector to emitter leakage current	I_{CES}	$V_{GE} = 0\text{ V}, V_{CE} = 600\text{ V}$	-	0.025	1	mA
		$V_{GE} = 0\text{ V}, V_{CE} = 600\text{ V}, T_J = 125\text{ °C}$	-	-	10	
Gate to emitter leakage current	I_{GES}	$V_{GE} = \pm 20\text{ V}$	-	-	± 250	nA

SWITCHING CHARACTERISTICS ($T_J = 25\text{ }^\circ\text{C}$ unless otherwise specified)						
PARAMETER	SYMBOL	TEST CONDITIONS	MIN.	TYP.	MAX.	UNITS
Total gate charge	Q_g	$I_C = 200\text{ A}$ $V_{CC} = 400\text{ V}$ $V_{GE} = 15\text{ V}$	-	1600	1700	nC
Gate to emitter charge	Q_{ge}		-	260	340	
Gate to collector charge	Q_{gc}		-	580	670	
Turn-on switching loss	E_{on}	$I_C = 200\text{ A}$, $V_{CC} = 480\text{ V}$, $V_{GE} = 15\text{ V}$ $R_g = 10\ \Omega$ Freewheeling diode: 30EPH06, $T_J = 25\text{ }^\circ\text{C}$	-	30	-	mJ
Turn-off switching loss	E_{off}		-	50	-	
Total switching loss	E_{ts}		-	80	-	
Turn-on switching loss	E_{on}	$I_C = 200\text{ A}$, $V_{CC} = 480\text{ V}$, $V_{GE} = 15\text{ V}$ $R_g = 10\ \Omega$ Freewheeling diode: 30EPH06, $T_J = 125\text{ }^\circ\text{C}$	-	34	-	mJ
Turn-off switching loss	E_{off}		-	104	-	
Total switching loss	E_{ts}		-	138	151	
Input capacitance	C_{ies}	$V_{GE} = 0\text{ V}$ $V_{CC} = 30\text{ V}$ $f = 1.0\text{ MHz}$	-	32 500	-	pF
Output capacitance	C_{oes}		-	2080	-	
Reverse transfer capacitance	C_{res}		-	380	-	

THERMAL AND MECHANICAL SPECIFICATIONS					
PARAMETER	SYMBOL	MIN.	TYP.	MAX.	UNITS
Operating junction temperature range	T_J	- 40	-	150	$^\circ\text{C}$
Storage temperature range	T_{Stg}	- 40	-	125	
Junction to case per leg	R_{thJC}	-	-	0.15	$^\circ\text{C/W}$
Case to sink	R_{thCS}	-	0.1	-	
Mounting torque	case to heatsink	-	-	4	Nm
	case to terminal 1, 2, 3	-	-	3	
Weight		-	185	-	g

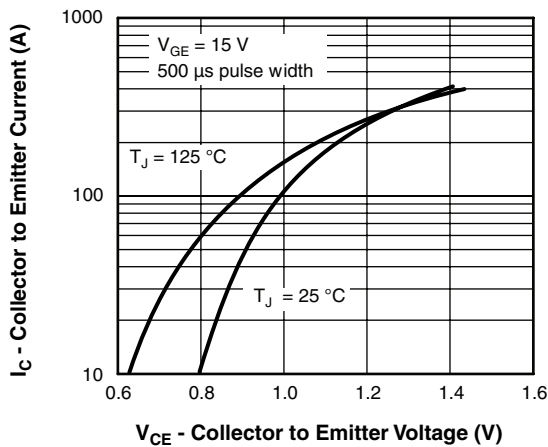

Fig. 1 - Typical Output Characteristics

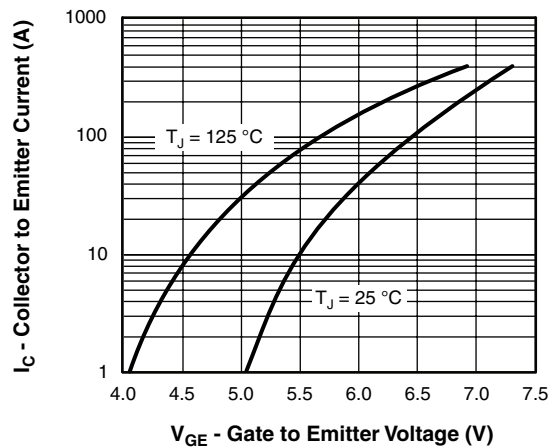

Fig. 2 - Typical Transfer Characteristics

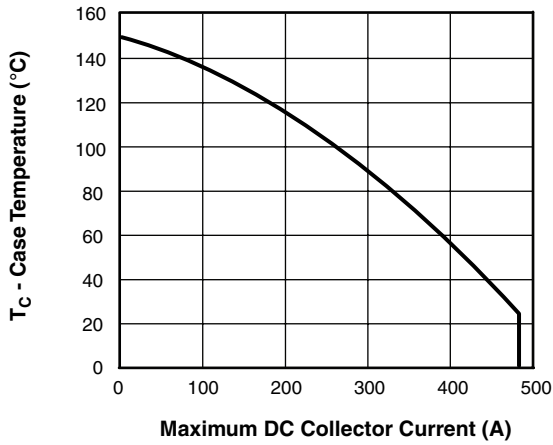

Fig. 3 - Case Temperature vs. Maximum Collector Current

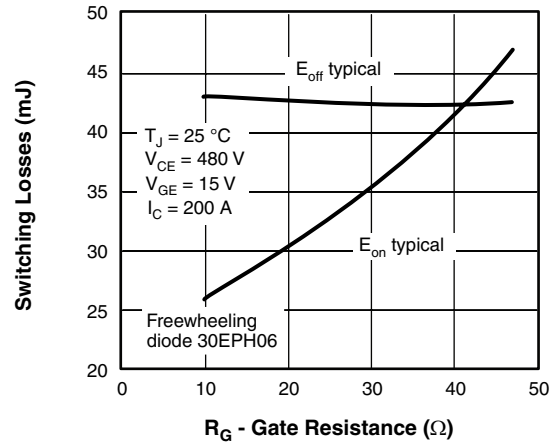

Fig. 6 - Typical Switching Losses vs. Gate Resistance

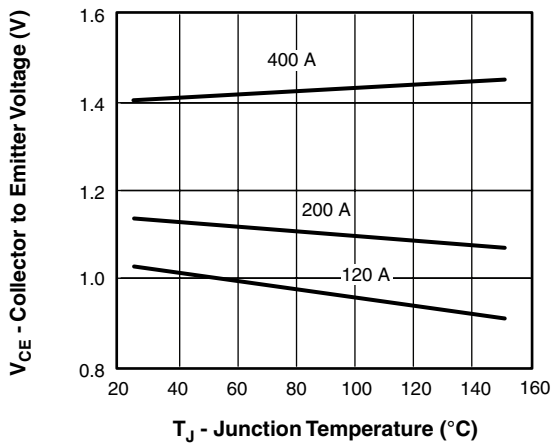

Fig. 4 - Typical Collector to Emitter Voltage vs. Junction Temperature

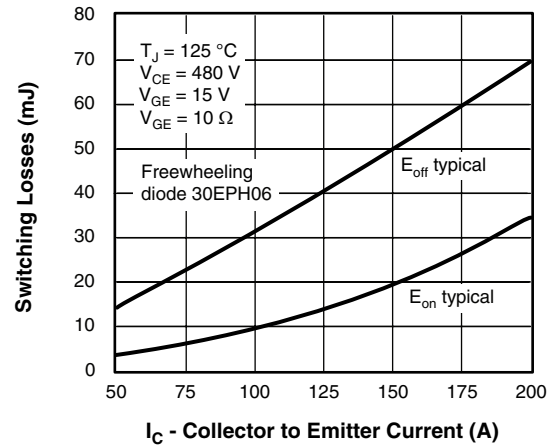

Fig. 7 - Typical Switching Losses vs. Collector to Emitter Current

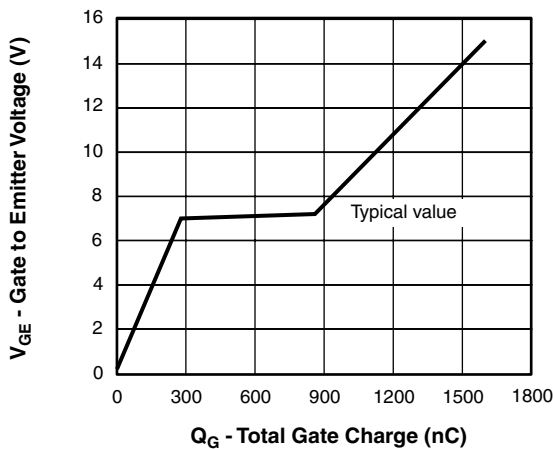
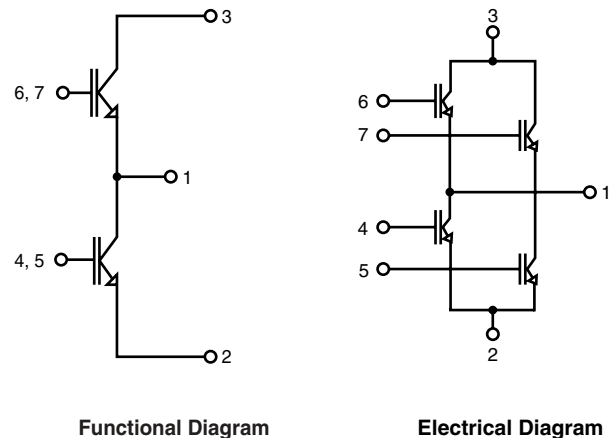

Fig. 5 - Typical Gate Charge vs. Gate to Emitter Voltage



Functional Diagram

Electrical Diagram

GA200HS60S1PbF



Vishay High Power Products "Half-Bridge" IGBT INT-A-PAK
(Standard Speed IGBT), 200 A

ORDERING INFORMATION TABLE

Device code	GA	200	H	S	60	S	1	PbF
	①	②	③	④	⑤	⑥	⑦	⑧
	1	-	Essential part number IGBT modules					
	2	-	Current rating (200 = 200 A)					
	3	-	Circuit configuration (H = Half bridge without f/w diode)					
	4	-	INT-A-PAK					
	5	-	Voltage code (60 = 600 V)					
	6	-	Speed/type (S = Standard speed IGBT)					
	7	-	Assy location Italy					
	8	-	PbF = Lead (Pb)-free					

LINKS TO RELATED DOCUMENTS	
Dimensions	www.vishay.com/doc?95067

INT-A-PAK IGBT/Thyristor

DIMENSIONS in millimeters (inches)

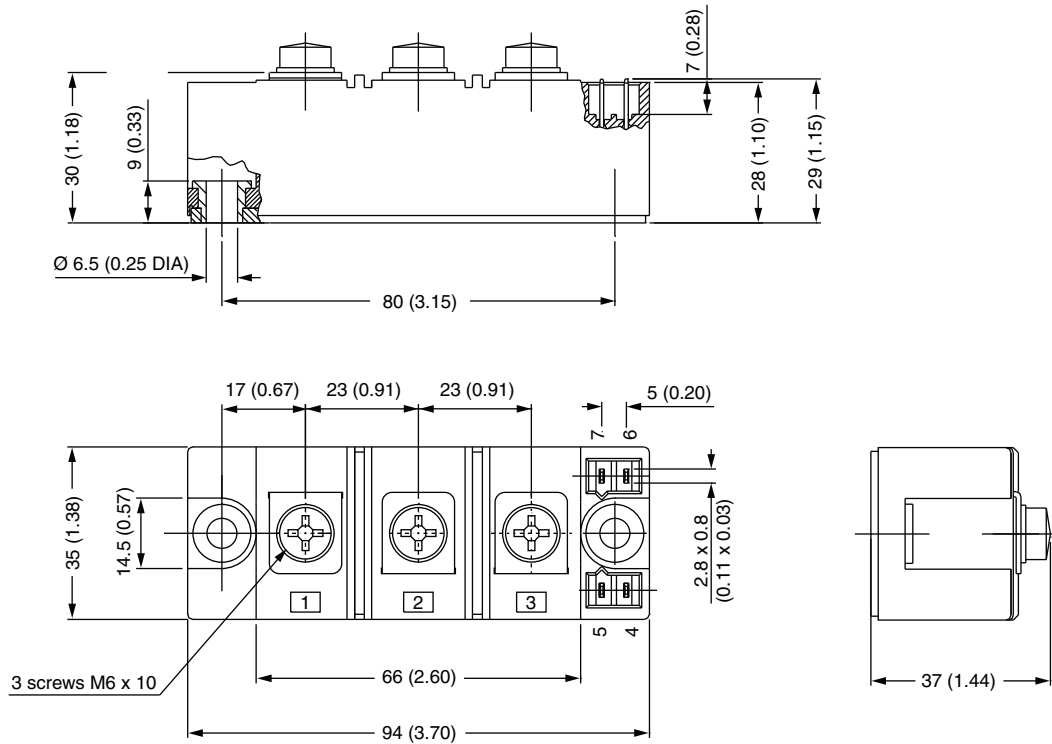



Disclaimer

ALL PRODUCT, PRODUCT SPECIFICATIONS AND DATA ARE SUBJECT TO CHANGE WITHOUT NOTICE TO IMPROVE RELIABILITY, FUNCTION OR DESIGN OR OTHERWISE.

Vishay Intertechnology, Inc., its affiliates, agents, and employees, and all persons acting on its or their behalf (collectively, "Vishay"), disclaim any and all liability for any errors, inaccuracies or incompleteness contained in any datasheet or in any other disclosure relating to any product.

Vishay makes no warranty, representation or guarantee regarding the suitability of the products for any particular purpose or the continuing production of any product. To the maximum extent permitted by applicable law, Vishay disclaims (i) any and all liability arising out of the application or use of any product, (ii) any and all liability, including without limitation special, consequential or incidental damages, and (iii) any and all implied warranties, including warranties of fitness for particular purpose, non-infringement and merchantability.

Statements regarding the suitability of products for certain types of applications are based on Vishay's knowledge of typical requirements that are often placed on Vishay products in generic applications. Such statements are not binding statements about the suitability of products for a particular application. It is the customer's responsibility to validate that a particular product with the properties described in the product specification is suitable for use in a particular application. Parameters provided in datasheets and/or specifications may vary in different applications and performance may vary over time. All operating parameters, including typical parameters, must be validated for each customer application by the customer's technical experts. Product specifications do not expand or otherwise modify Vishay's terms and conditions of purchase, including but not limited to the warranty expressed therein.

Except as expressly indicated in writing, Vishay products are not designed for use in medical, life-saving, or life-sustaining applications or for any other application in which the failure of the Vishay product could result in personal injury or death. Customers using or selling Vishay products not expressly indicated for use in such applications do so at their own risk and agree to fully indemnify and hold Vishay and its distributors harmless from and against any and all claims, liabilities, expenses and damages arising or resulting in connection with such use or sale, including attorneys fees, even if such claim alleges that Vishay or its distributor was negligent regarding the design or manufacture of the part. Please contact authorized Vishay personnel to obtain written terms and conditions regarding products designed for such applications.

No license, express or implied, by estoppel or otherwise, to any intellectual property rights is granted by this document or by any conduct of Vishay. Product names and markings noted herein may be trademarks of their respective owners.

Material Category Policy

Vishay Intertechnology, Inc. hereby certifies that all its products that are identified as RoHS-Compliant fulfill the definitions and restrictions defined under Directive 2011/65/EU of The European Parliament and of the Council of June 8, 2011 on the restriction of the use of certain hazardous substances in electrical and electronic equipment (EEE) - recast, unless otherwise specified as non-compliant.

Please note that some Vishay documentation may still make reference to RoHS Directive 2002/95/EC. We confirm that all the products identified as being compliant to Directive 2002/95/EC conform to Directive 2011/65/EU.