

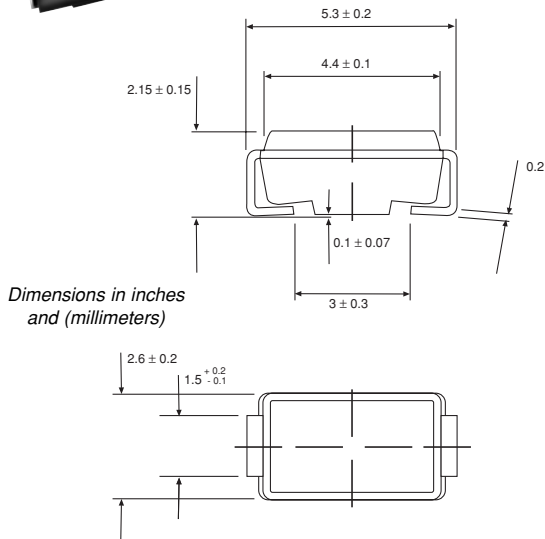

**DO-214AC
(SMA)**

Schottky Barrier Rectifiers

**Reverse Voltage 90
Forward Current 1.0A**



Mounting Pad Layout

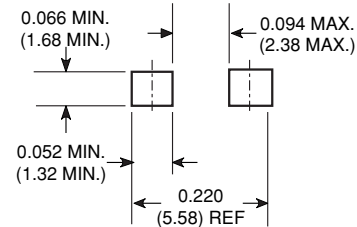

Mechanical Data

Case: JEDEC DO-214AC molded plastic body
Terminals: Solder plated, solderable per MIL-STD-750, Method 2026
High temperature soldering guaranteed: 250°C/10 seconds at terminals
Polarity: Color band denotes cathode end
Weight: 0.002oz., 0.064g

Features

- Low power loss, high efficiency
- Low profile surface mount package
- Built-in strain relief
- Very low switching losses
- Low reverse current
- High surge capability
- Guardring for overvoltage protection
- Plastic package has Underwriters Laboratory Flammability Classification 94V-0

Maximum Ratings and Thermal Characteristics (T_A = 25°C unless otherwise noted)

Parameter	Symbol	BYS12-90	Unit
Device marking code		BYS 209	
Maximum repetitive peak reverse voltage	V _{RRM}	90	V
Maximum average forward rectified current	I _{F(AV)}	1.5	A
Peak forward surge current single half sine-wave superimposed on rated load	I _{FSM}	40 30	A
Maximum Thermal Resistance – Junction Ambient	R _{θJA}	150 ⁽¹⁾ 125 ⁽²⁾ 100 ⁽³⁾	°C/W
Voltage rate of change (V _R)	dv/dt	10,000	V/μs
Junction and storage temperature range	T _J , T _{STG}	-55 to +150	°C

Electrical Characteristics (T_A = 25°C unless otherwise noted)

Maximum instantaneous forward voltage at: ⁽⁴⁾	I _F = 1A I _F = 15mA	V _F	750 360	mV
Maximum DC reverse current at V _{RRM} ⁽⁴⁾	T _J = 25°C T _J = 100°C	I _R	100 1	μA mA

Notes: (1) Mounted on epoxy-glass hard tissue
 (2) Mounted on epoxy-glass hard tissue, 50 mm² 35 μm Cu
 (3) Mounted on Al-oxide-ceramic (Al₂O₃), 50 mm² 35 μm Cu
 (4) Pulse test: 300μs pulse width, 1% duty cycle



Ratings and Characteristic Curves ($T_A = 25^\circ\text{C}$ unless otherwise noted)

Fig. 1 – Forward Current vs. Forward Voltage

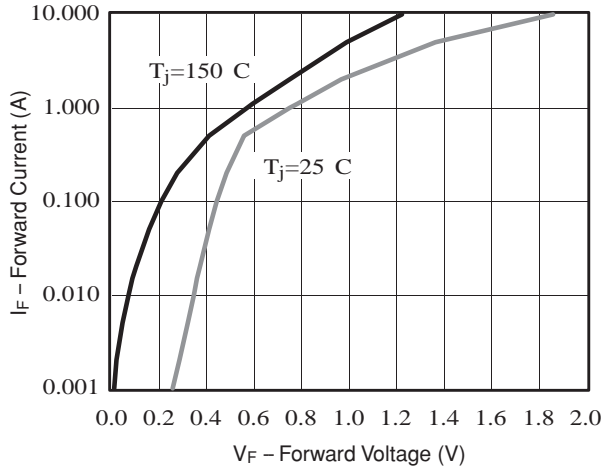

Fig. 4 – Reverse Current vs. Junction Temperature

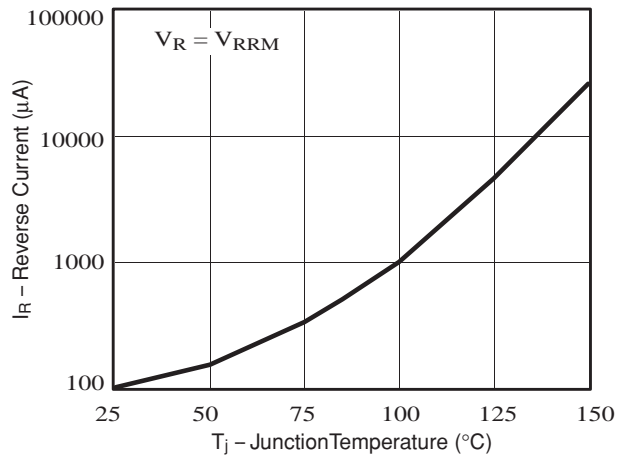

Fig. 2 – Max. Average Forward Current vs. Ambient Temperature

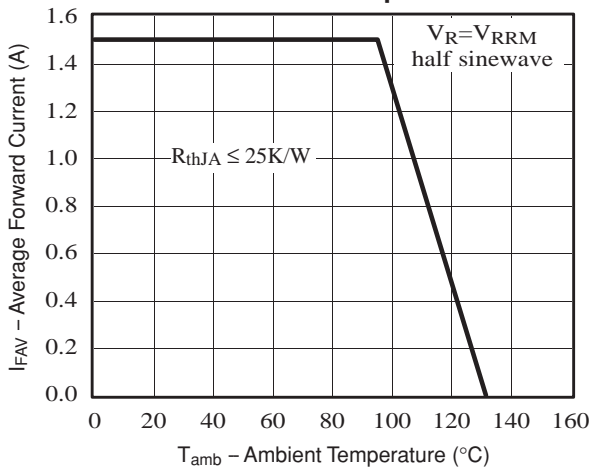

Fig. 5 – Max. Reverse Power Dissipation vs. Junction Temperature

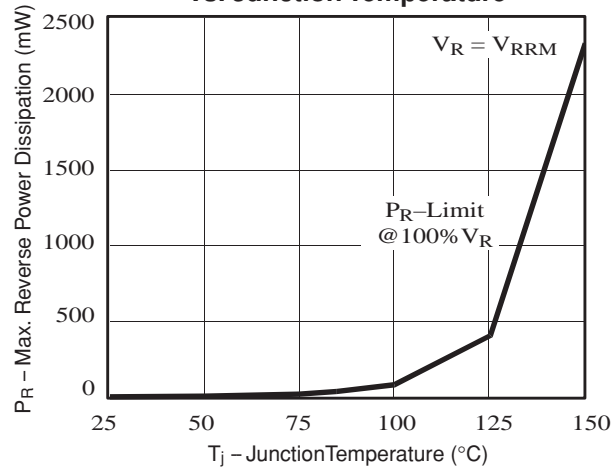

Fig. 3 – Max. Average Forward Current vs. Ambient Temperature

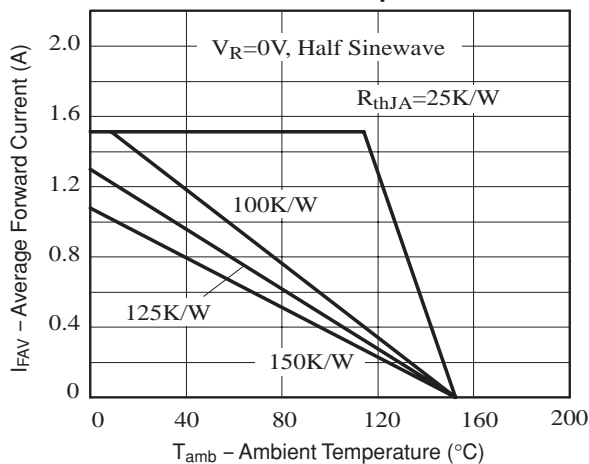
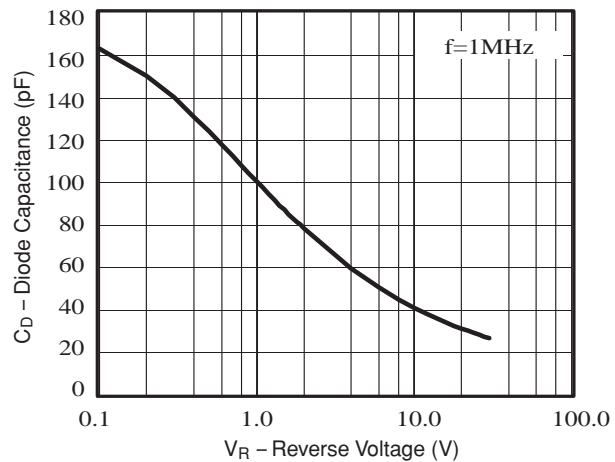

Fig. 6 – Diode Capacitance vs. Reverse Voltage





Notice

Specifications of the products displayed herein are subject to change without notice. Vishay Intertechnology, Inc., or anyone on its behalf, assumes no responsibility or liability for any errors or inaccuracies.

Information contained herein is intended to provide a product description only. No license, express or implied, by estoppel or otherwise, to any intellectual property rights is granted by this document. Except as provided in Vishay's terms and conditions of sale for such products, Vishay assumes no liability whatsoever, and disclaims any express or implied warranty, relating to sale and/or use of Vishay products including liability or warranties relating to fitness for a particular purpose, merchantability, or infringement of any patent, copyright, or other intellectual property right.

The products shown herein are not designed for use in medical, life-saving, or life-sustaining applications. Customers using or selling these products for use in such applications do so at their own risk and agree to fully indemnify Vishay for any damages resulting from such improper use or sale.