

## Silicon Epitaxial Planar Z-Diodes

### Features

- Zener voltage specified at 50  $\mu\text{A}$
- Maximum delta  $V_Z$  given from 10  $\mu\text{A}$  to 100  $\mu\text{A}$
- Very high stability
- Low noise

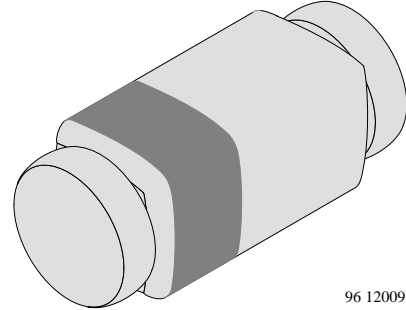

96 12009

### Applications

Voltage stabilization

### Order Instruction

Type	Ordering Code	Remarks
TZS4678	TZS4678-GS08	Tape and Reel

### Absolute Maximum Ratings

 $T_j = 25^\circ\text{C}$ 

Parameter	Test Conditions	Type	Symbol	Value	Unit
Power dissipation	$R_{thJA} \leq 300\text{K/W}$		$P_V$	500	mW
Z-current			$I_Z$	$P_V/V_Z$	mA
Junction temperature			$T_j$	175	$^\circ\text{C}$
Storage temperature range			$T_{stg}$	-65...+175	$^\circ\text{C}$

### Maximum Thermal Resistance

 $T_j = 25^\circ\text{C}$ 

Parameter	Test Conditions	Symbol	Value	Unit
Junction ambient	on PC board 50 mmx50 mmx1.6 mm	$R_{thJA}$	500	K/W

### Electrical Characteristics

 $T_j = 25^\circ\text{C}$ 

Parameter	Test Conditions	Type	Symbol	Min	Typ	Max	Unit
Forward voltage	$I_F=100\text{mA}$		$V_F$			1.5	V

Type <sup>1)</sup>	Zener Voltage $V_Z$ @ $I_Z = 50\mu A$			Max. Reverse Current	Test Voltage	Max. Zener Current	Max. Voltage Change
	Typ. <sup>1)</sup>	Min.	Max.	$I_R$ <sup>3)</sup>	$V_R$ <sup>3)</sup>	$I_{ZM}$ <sup>2)</sup>	$\Delta V_Z$ <sup>4)</sup>
	V	V	V	$\mu A$	V	mA	V
TZS4678	1.8	1.710	1.890	7.5	1.0	120	0.70
TZS4679	2.0	1.900	2.100	5.0	1.0	110	0.70
TZS4680	2.2	2.090	2.310	4.0	1.0	100	0.75
TZS4681	2.4	2.280	2.520	2.0	1.0	95	0.80
TZS4682	2.7	2.565	2.835	1.0	1.0	90	0.85
TZS4683	3.0	2.850	3.150	0.8	1.0	85	0.90
TZS4684	3.3	3.135	3.465	7.5	1.5	80	0.95
TZS4685	3.6	3.420	3.780	7.5	2.0	75	0.95
TZS4686	3.9	3.705	4.095	5.0	2.0	70	0.97
TZS4687	4.3	4.085	4.515	4.0	2.0	65	0.99
TZS4688	4.7	4.465	4.935	10	3.0	60	0.99
TZS4689	5.1	4.845	5.355	10	3.0	55	0.97
TZS4690	5.6	5.320	5.880	10	4.0	50	0.96
TZS4691	6.2	5.890	6.510	10	5.0	45	0.95
TZS4692	6.8	6.460	7.140	10	5.1	35	0.90
TZS4693	7.5	7.125	7.875	10	5.7	31.8	0.75
TZS4694	8.2	7.790	8.610	1.0	6.2	29.0	0.50
TZS4695	8.7	8.265	9.135	1.0	6.6	27.4	0.10
TZS4696	9.1	8.645	9.555	1.0	6.9	26.2	0.08
TZS4697	10	9.500	10.50	1.0	7.6	24.8	0.10
TZS4698	11	10.45	11.55	0,05	8.4	21.6	0.11
TZS4699	12	11.40	12.60	0.05	9.1	20.4	0.12
TZS4700	13	12.35	13.65	0.05	9.8	19.0	0.13
TZS4701	14	13.30	14.70	0.05	10.6	17.5	0.14
TZS4702	15	14.25	15.75	0.05	11.4	16.3	0.15
TZS4703	16	15.20	16.80	0.05	12.1	15.4	0.16
TZS4704	17	16.15	17.85	0.05	12.9	14.5	0.17
TZS4705	18	17.10	18.90	0.05	13.6	13.2	0.18
TZS4706	19	18.05	19.95	0.05	14.4	12.5	0.19
TZS4707	20	19.00	21.00	0.01	15.2	11.9	0.20
TZS4708	22	20.90	23.10	0.01	16.7	10.8	0.22
TZS4709	24	22.80	25.20	0.01	18.2	9.9	0.24
TZS4710	25	23.75	26.25	0.01	19.0	9.5	0.25
TZS4711	27	25.65	28.35	0.01	20.4	8.8	0.27
TZS4712	28	26.60	29.40	0.01	21.2	8.5	0.28
TZS4713	30	28.50	31.50	0.01	22.8	7.9	0.30
TZS4714	33	31.35	34.65	0.01	25.0	7.2	0.33
TZS4715	36	34.20	37.80	0.01	27.3	6.6	0.36
TZS4716	39	37.05	40.95	0.01	29.6	6.1	0.39
TZS4717	43	40.85	45.15	0.01	32.6	5.5	0.43

- 1.) Tolerancing and voltage designation ( $V_Z$ ).  
The type numbers shown have a standard tolerance of  $\pm 5\%$  on the nominal zener voltage.
- 2.) Maximum zener current ratings ( $I_{ZM}$ ).  
Maximum zener current ratings are based on maximum zener voltage of the individual units.
- 3.) Reverse leakage current ( $I_R$ ).  
Reverse leakage currents are guaranteed and measured at  $V_R$  as shown on the table.
- 4.) Maximum voltage change ( $\Delta V_Z$ ).  
Voltage change is equal to the difference between  $V_Z$  at  $100\mu A$  and  $V_Z$  at  $10\mu A$ .

## Characteristics ( $T_j = 25^\circ C$ unless otherwise specified)

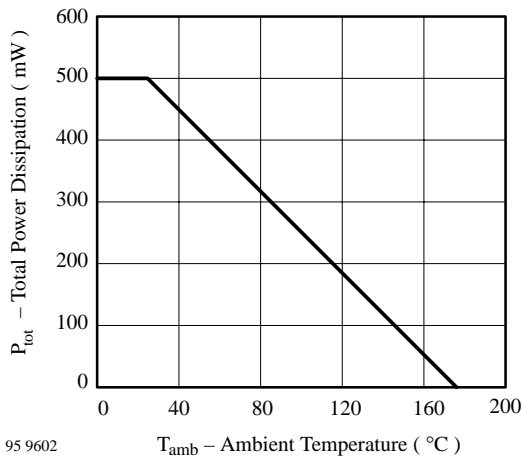

Figure 1. Total Power Dissipation vs. Ambient Temperature

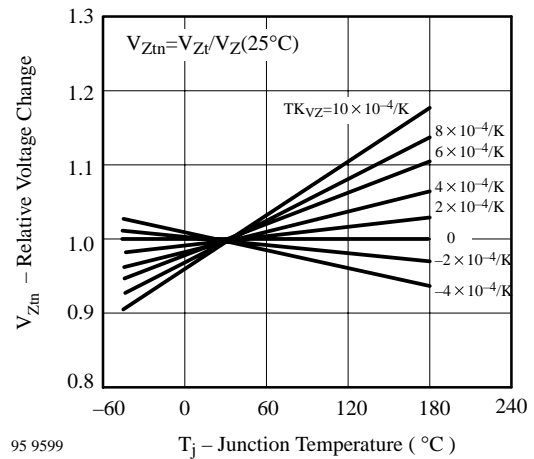

Figure 3. Typical Change of Working Voltage vs. Junction Temperature

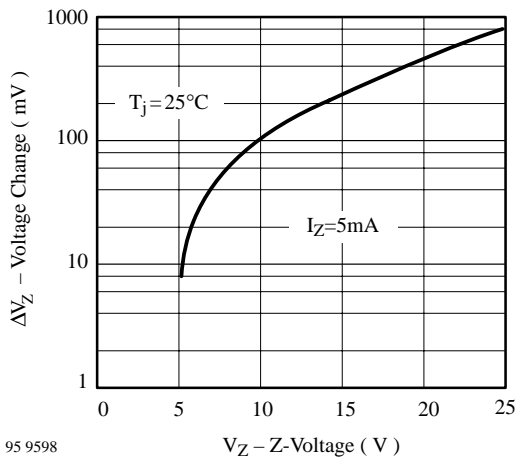

Figure 2. Typical Change of Working Voltage under Operating Conditions at  $T_{amb}=25^\circ C$

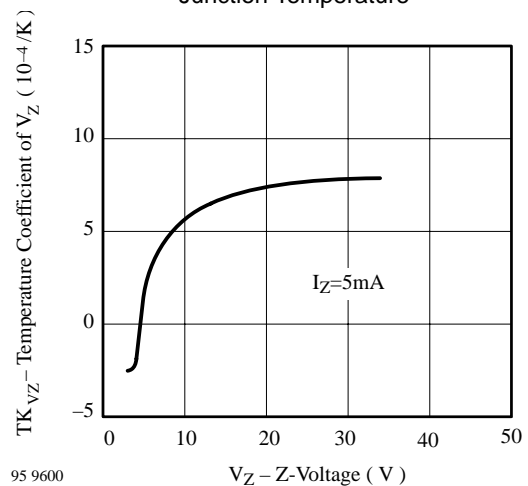

Figure 4. Temperature Coefficient of  $V_Z$  vs. Z-Voltage

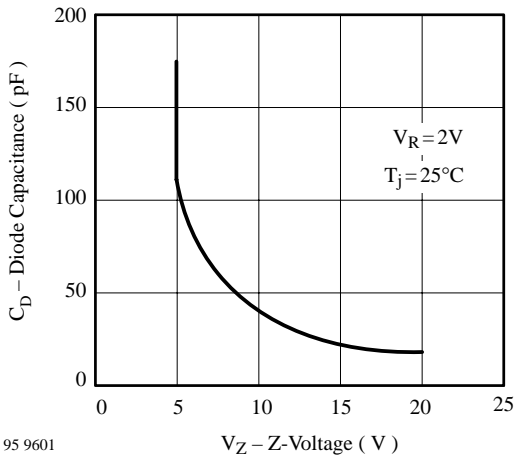

Figure 5. Diode Capacitance vs. Z-Voltage

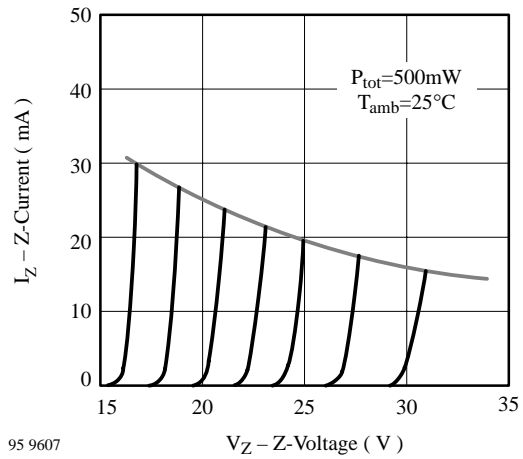

Figure 8. Z-Current vs. Z-Voltage

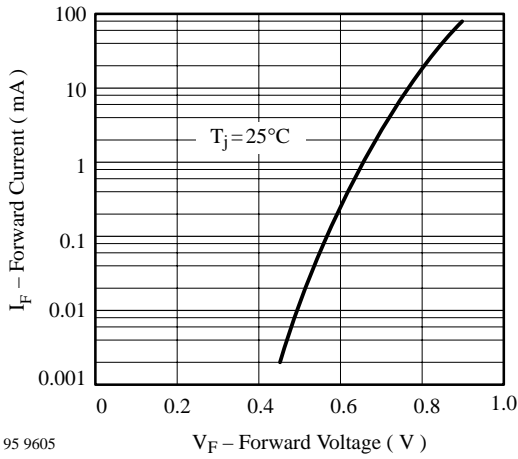

Figure 6. Forward Current vs. Forward Voltage

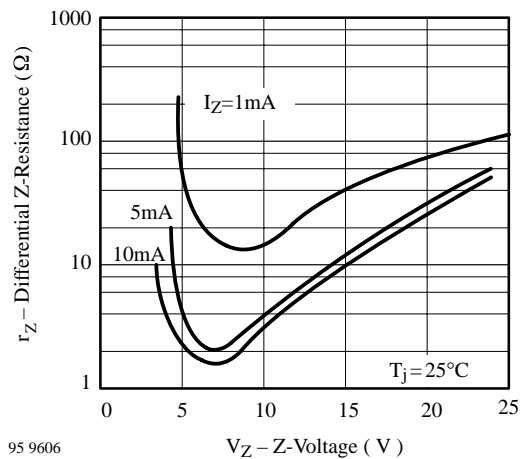

Figure 9. Differential Z-Resistance vs. Z-Voltage

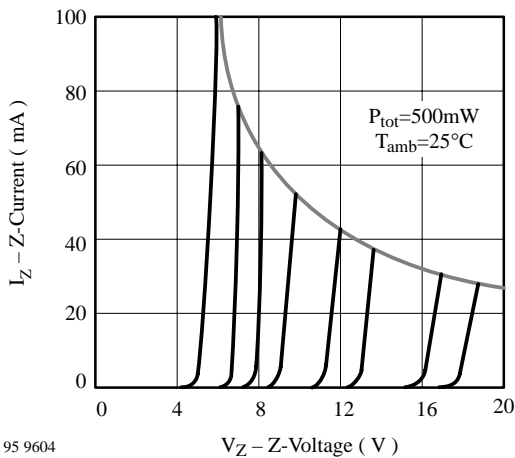

Figure 7. Z-Current vs. Z-Voltage

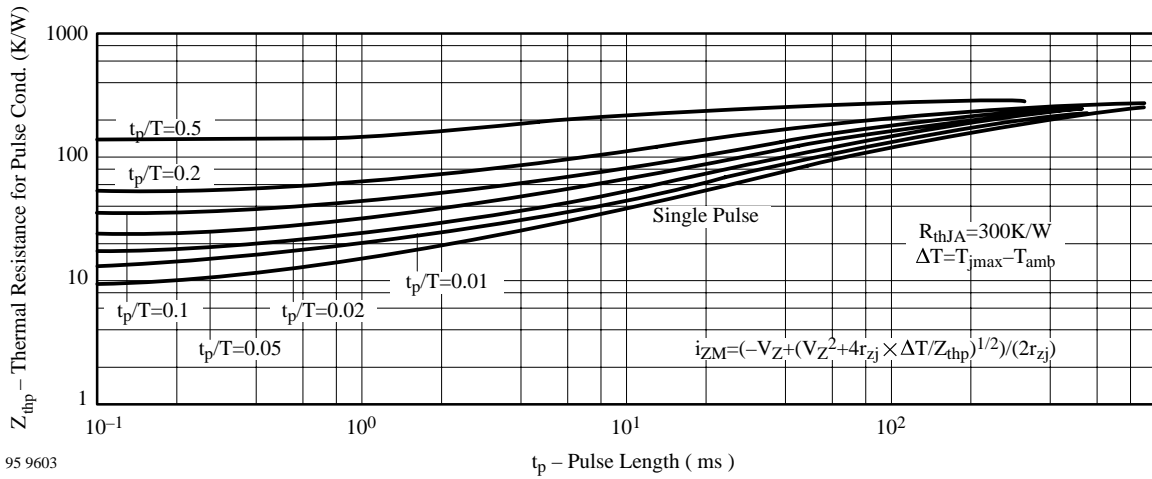
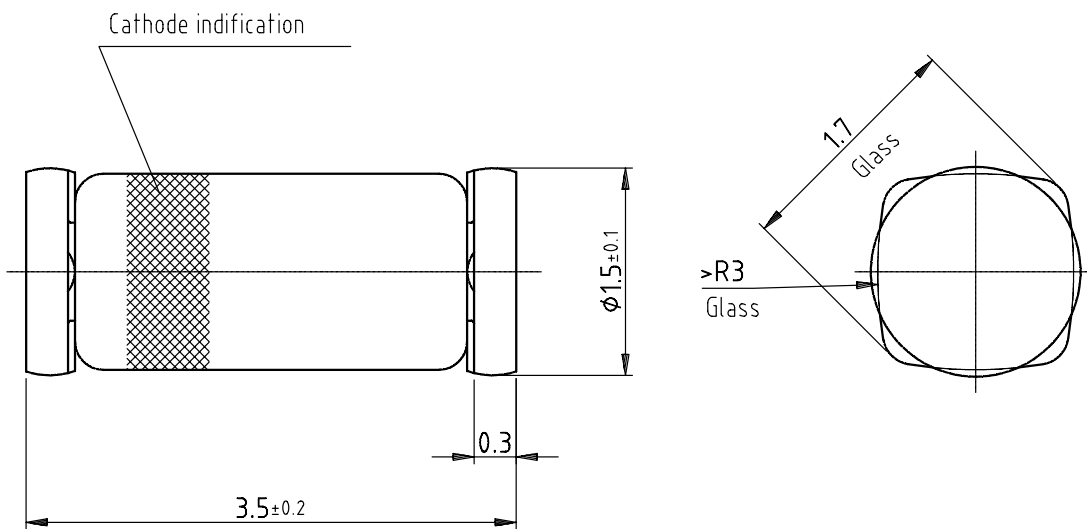

Figure 10. Thermal Response

## Dimensions in mm



Glass case  
Quadro MELF / SOD80  
similar to JEDEC 213 AA

96 12071  
technical drawings  
according to DIN  
specifications

### Ozone Depleting Substances Policy Statement

It is the policy of **Vishay Semiconductor GmbH** to

1. Meet all present and future national and international statutory requirements.
2. Regularly and continuously improve the performance of our products, processes, distribution and operating systems  
with respect to their impact on the health and safety of our employees and the public, as well as their impact on the environment.

It is particular concern to control or eliminate releases of those substances into the atmosphere which are known as ozone depleting substances (ODSs).

The Montreal Protocol (1987) and its London Amendments (1990) intend to severely restrict the use of ODSs and forbid their use within the next ten years. Various national and international initiatives are pressing for an earlier ban on these substances.

**Vishay Semiconductor GmbH** has been able to use its policy of continuous improvements to eliminate the use of ODSs listed in the following documents.

1. Annex A, B and list of transitional substances of the Montreal Protocol and the London Amendments respectively
2. Class I and II ozone depleting substances in the Clean Air Act Amendments of 1990 by the Environmental Protection Agency (EPA) in the USA
3. Council Decision 88/540/EEC and 91/690/EEC Annex A, B and C (transitional substances) respectively.

**Vishay Semiconductor GmbH** can certify that our semiconductors are not manufactured with ozone depleting substances and do not contain such substances.

**We reserve the right to make changes to improve technical design and may do so without further notice.**

Parameters can vary in different applications. All operating parameters must be validated for each customer application by the customer. Should the buyer use Vishay Semiconductors products for any unintended or unauthorized application, the buyer shall indemnify Vishay Semiconductors against all claims, costs, damages, and expenses, arising out of, directly or indirectly, any claim of personal damage, injury or death associated with such unintended or unauthorized use.

Vishay Semiconductor GmbH, P.O.B. 3535, D-74025 Heilbronn, Germany  
Telephone: 49 (0)7131 67 2831, Fax number: 49 (0)7131 67 2423