

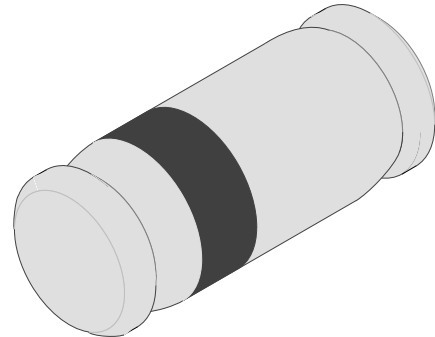

Silicon Z-Diodes

Features

- Very sharp reverse characteristic
- Very high stability
- Electrical data identical with the devices 1N5221B...1N5267B
- Low reverse current level
- V_Z -tolerance $\pm 5\%$



94 9371

Applications

Voltage stabilization

Order Instruction

Type	Ordering Code	Remarks
TZM5221B	TZM5221B-GS08	Tape and Reel (2.500 pcs)
	TZM5221B-GS18	Tape and Reel (10.000 pcs)

Absolute Maximum Ratings

$T_j = 25^\circ\text{C}$

Parameter	Test Conditions	Type	Symbol	Value	Unit
Power dissipation	$R_{thJA} < 300\text{K/W}$, $T_{amb} = 25^\circ\text{C}$		P_V	500	mW
Z-current			I_Z	P_V/V_Z	mA
Junction temperature			T_j	175	$^\circ\text{C}$
Storage temperature range			T_{stg}	-65...+175	$^\circ\text{C}$

Maximum Thermal Resistance

$T_j = 25^\circ\text{C}$

Parameter	Test Conditions	Symbol	Value	Unit
Junction ambient	on PC board 50 mmx50 mmx1.6 mm	R_{thJA}	500	K/W

Electrical Characteristics

$T_j = 25^\circ\text{C}$

Parameter	Test Conditions	Type	Symbol	Min	Typ	Max	Unit
Forward voltage	$I_F = 200\text{mA}$		V_F			1.1	V

TZM5221B...TZM5267B



Vishay Semiconductors

Type	$V_{Znom}^{1)}$	I_{ZT} for r_{zIT}		r_{zIK} at I_{ZK}		I_R at V_R		TK_{VZ}
	V	mA	Ω	Ω	mA	μA	V	%/K
TZM5221B	2.4	20	< 30	< 1200	0.25	< 100	1.0	< -0.085
TZM5222B	2.5	20	< 30	< 1250	0.25	< 100	1.0	< -0.085
TZM5223B	2.7	20	< 30	< 1300	0.25	< 75	1.0	< -0.080
TZM5224B	2.8	20	< 30	< 1400	0.25	< 75	1.0	< -0.080
TZM5225B	3.0	20	< 29	< 1600	0.25	< 50	1.0	< -0.075
TZM5226B	3.3	20	< 28	< 1600	0.25	< 25	1.0	< -0.070
TZM5227B	3.6	20	< 24	< 1700	0.25	< 15	1.0	< -0.065
TZM5228B	3.9	20	< 23	< 1900	0.25	< 10	1.0	< -0.060
TZM5229B	4.3	20	< 22	< 2000	0.25	< 5	1.0	< ± 0.055
TZM5230B	4.7	20	< 19	< 1900	0.25	< 5	2.0	< ± 0.030
TZM5231B	5.1	20	< 17	< 1600	0.25	< 5	2.0	< ± 0.030
TZM5232B	5.6	20	< 11	< 1600	0.25	< 5	3.0	< +0.038
TZM5233B	6.0	20	< 7	< 1600	0.25	< 5	3.5	< +0.038
TZM5234B	6.2	20	< 7	< 1000	0.25	< 5	4.0	< +0.045
TZM5235B	6.8	20	< 5	< 750	0.25	< 3	5.0	< +0.050
TZM5236B	7.5	20	< 6	< 500	0.25	< 3	6.0	< +0.058
TZM5237B	8.2	20	< 8	< 500	0.25	< 3	6.5	< +0.062
TZM5238B	8.7	20	< 8	< 600	0.25	< 3	6.5	< +0.065
TZM5239B	9.1	20	< 10	< 600	0.25	< 3	7.0	< +0.068
TZM5240B	10	20	< 17	< 600	0.25	< 3	8.0	< +0.075
TZM5241B	11	20	< 22	< 600	0.25	< 2	8.4	< +0.076
TZM5242B	12	20	< 30	< 600	0.25	< 1	9.1	< +0.077
TZM5243B	13	9.5	< 13	< 600	0.25	< 0.5	9.9	< +0.079
TZM5244B	14	9.0	< 15	< 600	0.25	< 0.1	10	< +0.082
TZM5245B	15	8.5	< 16	< 600	0.25	< 0.1	11	< +0.082
TZM5246B	16	7.8	< 17	< 600	0.25	< 0.1	12	< +0.083
TZM5247B	17	7.4	< 19	< 600	0.25	< 0.1	13	< +0.084
TZM5248B	18	7.0	< 21	< 600	0.25	< 0.1	14	< +0.085
TZM5249B	19	6.6	< 23	< 600	0.25	< 0.1	14	< +0.086
TZM5250B	20	6.2	< 25	< 600	0.25	< 0.1	15	< +0.086
TZM5251B	22	5.6	< 29	< 600	0.25	< 0.1	17	< +0.087
TZM5252B	24	5.2	< 33	< 600	0.25	< 0.1	18	< +0.088
TZM5253B	25	5.0	< 35	< 600	0.25	< 0.1	19	< +0.089
TZM5254B	27	4.6	< 41	< 600	0.25	< 0.1	21	< +0.090
TZM5255B	28	4.5	< 44	< 600	0.25	< 0.1	21	< +0.091
TZM5256B	30	4.2	< 49	< 600	0.25	< 0.1	23	< +0.091
TZM5257B	33	3.8	< 58	< 700	0.25	< 0.1	25	< +0.092
TZM5258B	36	3.4	< 70	< 700	0.25	< 0.1	27	< +0.093
TZM5259B	39	3.2	< 80	< 800	0.25	< 0.1	30	< +0.094
TZM5260B	43	3.0	< 93	< 900	0.25	< 0.1	33	< +0.095
TZM5261B	47	2.7	< 105	< 1000	0.25	< 0.1	36	< +0.095
TZM5262B	51	2.5	< 125	< 1100	0.25	< 0.1	39	< +0.096
TZM5263B	56	2.2	< 150	< 1300	0.25	< 0.1	43	< +0.096
TZM5264B	60	2.1	< 170	< 1400	0.25	< 0.1	46	< +0.097
TZM5265B	62	2.0	< 185	< 1400	0.25	< 0.1	47	< +0.097
TZM5266B	68	1.8	< 230	< 1600	0.25	< 0.1	52	< +0.097
TZM5267B	75	1.7	< 270	< 1700	0.25	< 0.1	56	< +0.098

¹⁾ Based on dc-measurement at thermal equilibrium; case temperature maintained at 30°C ± 2°C.

Dimensions in mm

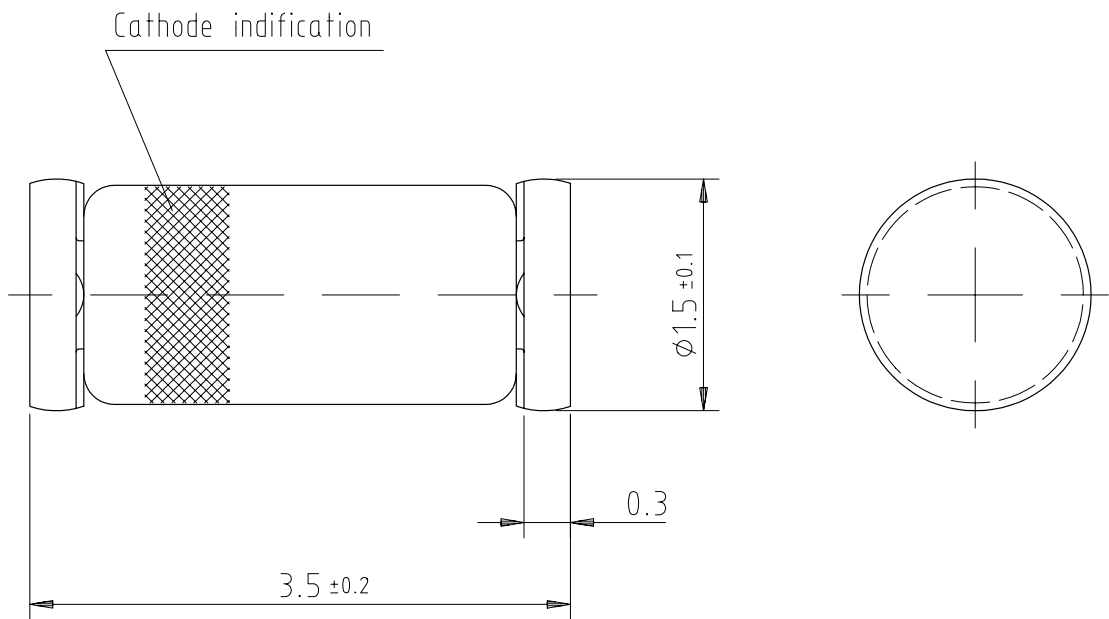

Glass case
Mini MELF / SOD 80
JEDEC DO 213 AA

96 12070

technical drawings
according to DIN
specifications

Ozone Depleting Substances Policy Statement

It is the policy of **Vishay Semiconductor GmbH** to

1. Meet all present and future national and international statutory requirements.
2. Regularly and continuously improve the performance of our products, processes, distribution and operating systems with respect to their impact on the health and safety of our employees and the public, as well as their impact on the environment.

It is particular concern to control or eliminate releases of those substances into the atmosphere which are known as ozone depleting substances (ODSs).

The Montreal Protocol (1987) and its London Amendments (1990) intend to severely restrict the use of ODSs and forbid their use within the next ten years. Various national and international initiatives are pressing for an earlier ban on these substances.

Vishay Semiconductor GmbH has been able to use its policy of continuous improvements to eliminate the use of ODSs listed in the following documents.

1. Annex A, B and list of transitional substances of the Montreal Protocol and the London Amendments respectively
2. Class I and II ozone depleting substances in the Clean Air Act Amendments of 1990 by the Environmental Protection Agency (EPA) in the USA
3. Council Decision 88/540/EEC and 91/690/EEC Annex A, B and C (transitional substances) respectively.

Vishay Semiconductor GmbH can certify that our semiconductors are not manufactured with ozone depleting substances and do not contain such substances.

We reserve the right to make changes to improve technical design and may do so without further notice.

Parameters can vary in different applications. All operating parameters must be validated for each customer application by the customer. Should the buyer use Vishay Semiconductors products for any unintended or unauthorized application, the buyer shall indemnify Vishay Semiconductors against all claims, costs, damages, and expenses, arising out of, directly or indirectly, any claim of personal damage, injury or death associated with such unintended or unauthorized use.

Vishay Semiconductor GmbH, P.O.B. 3535, D-74025 Heilbronn, Germany
Telephone: 49 (0)7131 67 2831, Fax number: 49 (0)7131 67 2423