

Silicon PIN Photodiode

Description

TEMD1000 series are high speed silicon PIN photodiodes molded in SMT package with dome lens.

Due to integrated Daylight filter devices are sensitive for IR radiation only.

High on axis sensitivity is provided by a viewing angle of $\pm 15^\circ$.

Features

- Extra fast response times
- Radiant sensitive area $A = 0.25 \text{ mm}^2$
- Daylight filter
- Versatile terminal configurations
- Package matched to IR Emitter series TSMF1000 and TSML1000
- Angle of half sensitivity $\phi = \pm 15^\circ$

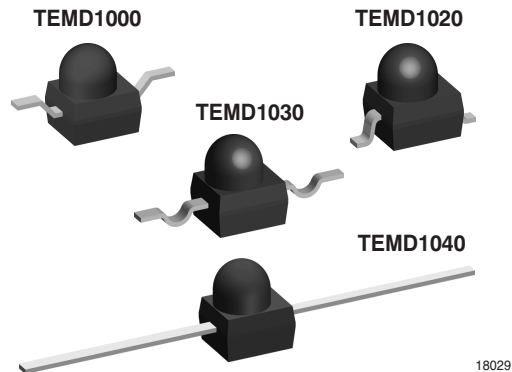

Applications

High speed detector for SMT

IR Detector for Daylight application

Absolute Maximum Ratings

$T_{\text{amb}} = 25^\circ\text{C}$, unless otherwise specified

Parameter	Test condition	Symbol	Value	Unit
Reverse Voltage		V_R	60	V
Power Dissipation	$T_{\text{amb}} \leq 25^\circ\text{C}$	P_V	75	mW
Junction Temperature		T_J	100	$^\circ\text{C}$
Storage Temperature Range		T_{stg}	- 40 to + 100	$^\circ\text{C}$
Operating Temperature Range		T_{stg}	- 40 to + 85	$^\circ\text{C}$
Soldering Temperature	$t \leq 5 \text{ s}$	T_{sd}	<260	$^\circ\text{C}$

Basic Characteristics

$T_{\text{amb}} = 25^\circ\text{C}$, unless otherwise specified

Parameter	Test condition	Symbol	Min	Typ.	Max	Unit
Forward Voltage	$I_F = 50 \text{ mA}$	V_F		1.0	1.3	V
Breakdown Voltage	$I_R = 100 \mu\text{A}$, $E = 0$	$V_{(BR)}$	60			V
Reverse Dark Current	$V_R = 10 \text{ V}$, $E = 0$	I_{ro}		1	10	nA
Diode Capacitance	$V_R = 5 \text{ V}$, $f = 1 \text{ MHz}$, $E = 0$	C_D		1.8		pF
Reverse Light Current	$E_e = 1 \text{ mW/cm}^2$, $\lambda = 870 \text{ nm}$, $V_R = 5 \text{ V}$	I_{ra}		10		μA
	$E_e = 1 \text{ mW/cm}^2$, $\lambda = 950 \text{ nm}$, $V_R = 5 \text{ V}$	I_{ra}	5	12		μA
Temp. Coefficient of I_{ra}	$V_R = 5 \text{ V}$, $\lambda = 870 \text{ nm}$	TK_{Ira}		0.2		%/K
Absolute Spectral Sensitivity	$V_R = 5 \text{ V}$, $\lambda = 870 \text{ nm}$	$s(\lambda)$		0.60		A/W
	$V_R = 5 \text{ V}$, $\lambda = 950 \text{ nm}$	$s(\lambda)$		0.55		A/W
Angle of Half Sensitivity		ϕ		± 15		deg
Wavelength of Peak Sensitivity		λ_p		900		nm

Parameter	Test condition	Symbol	Min	Typ.	Max	Unit
Range of Spectral Bandwidth		$\lambda_{0.5}$		840 to 1050		nm
Rise Time	$V_R = 10\text{ V}$, $R_L = 50\ \Omega$, $\lambda = 820\text{ nm}$	t_r		4		ns
Fall Time	$V_R = 10\text{ V}$, $R_L = 50\ \Omega$, $\lambda = 820\text{ nm}$	t_f		4		ns

Typical Characteristics ($T_{amb} = 25\text{ }^\circ\text{C}$ unless otherwise specified)

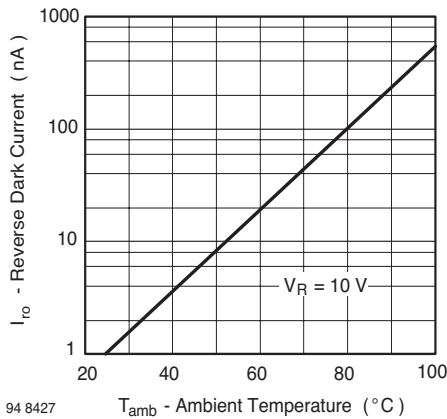

Figure 1. Reverse Dark Current vs. Ambient Temperature

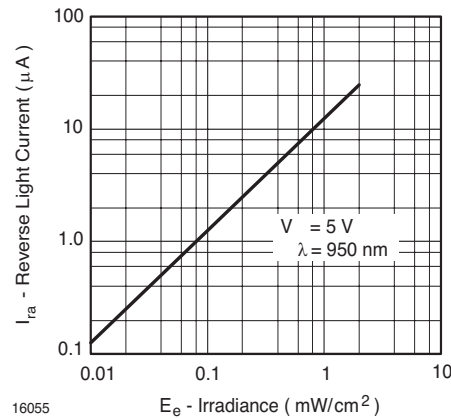

Figure 3. Reverse Light Current vs. Irradiance

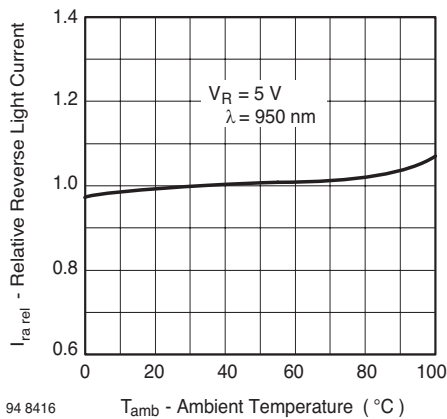

Figure 2. Relative Reverse Light Current vs. Ambient Temperature

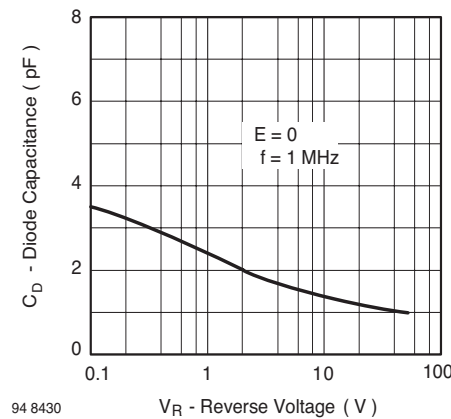

Figure 4. Diode Capacitance vs. Reverse Voltage

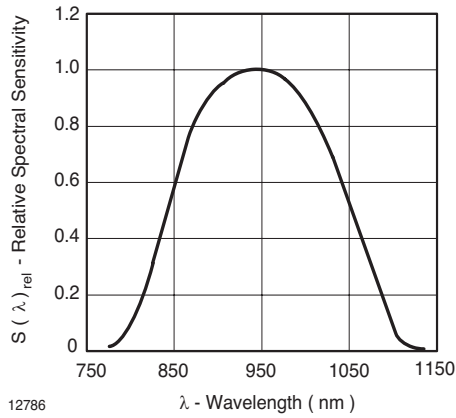

Figure 5. Relative Spectral Sensitivity vs. Wavelength

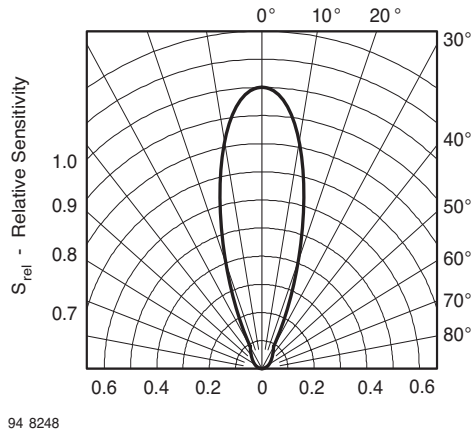

Figure 6. Relative Radiant Sensitivity vs. Angular Displacement

TEMD1000/1020/1030/1040



Vishay Semiconductors

Package Dimensions in mm TEMD1000

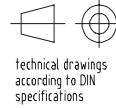
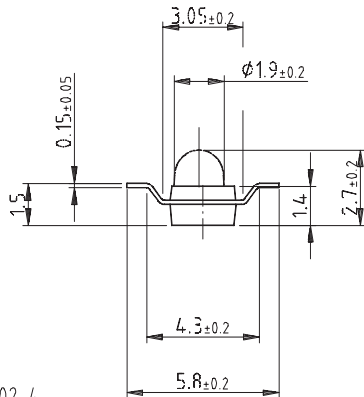

technical drawings
according to DIN
specifications

All dimensions in mm

Drawing-No.: 6.544-5326.02-4
Issue: 3; 02.04.03

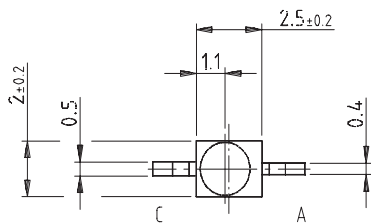

Solder pad proposal

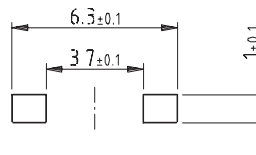

16159

Package Dimensions in mm TEMD1020

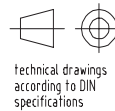
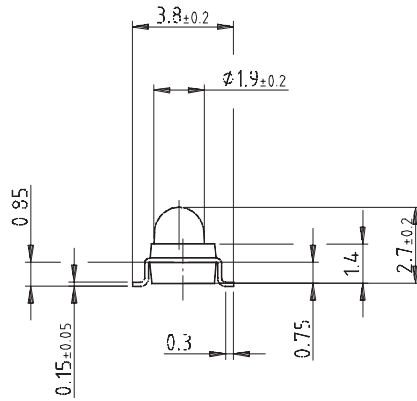

technical drawings
according to DIN
specifications

All dimensions in mm

Drawing-No.: 6.544-5325.02-4
Issue: 3; 02.04.03

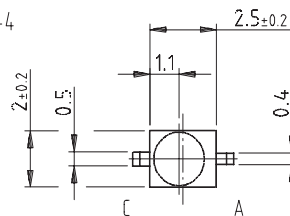

Solder pad proposal

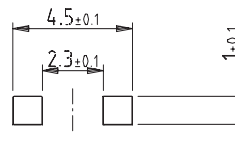

16160

Package Dimensions in mm
TEMD1030

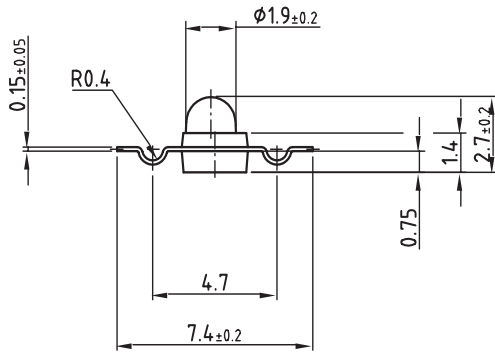

Drawing-No.: 6.544-5329.01-4
Issue: 4; 08.05.03

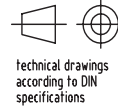

All dimensions in mm

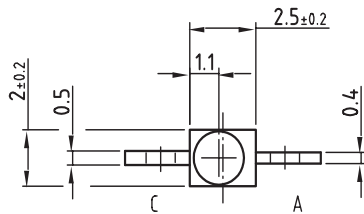

Solder pad proposal

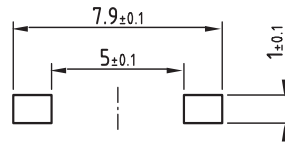

16228

Package Dimensions in mm
TEMD1040

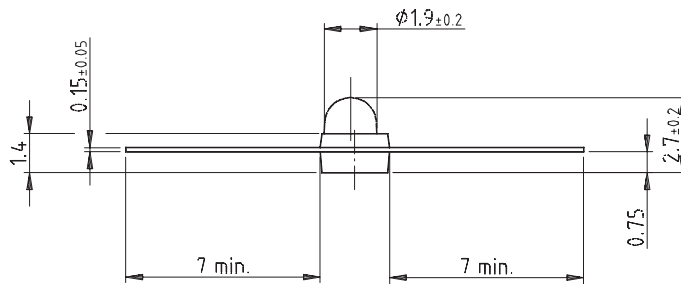

Drawing-No.: 6.544-5339.02-4
Issue: 3; 02.04.03

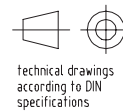

All dimensions in mm

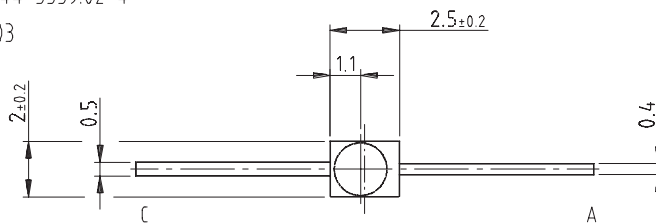

16760

Reel Dimensions

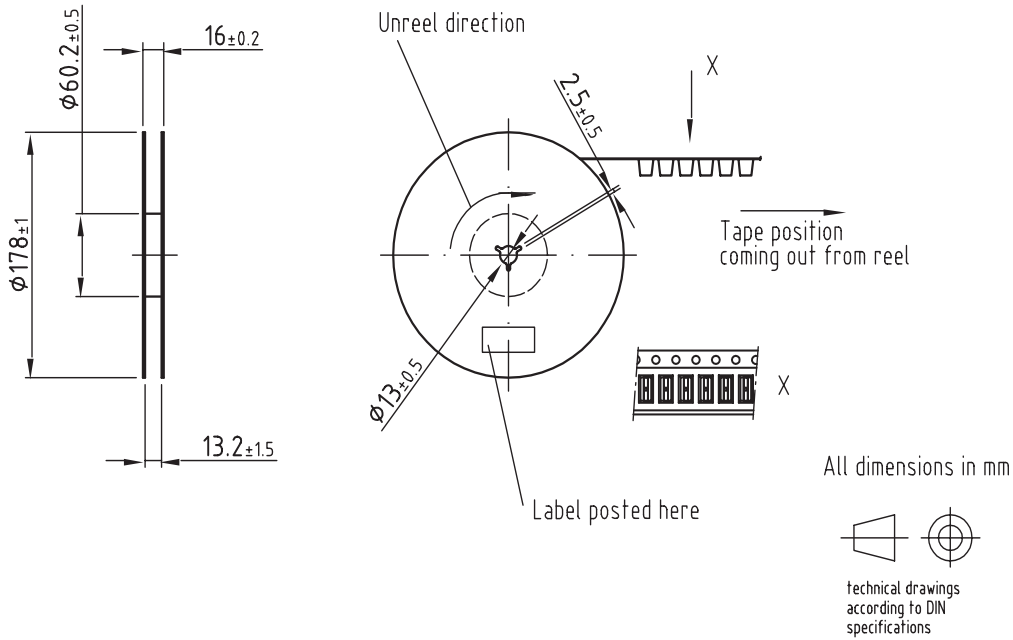

Leader and trailer tape:

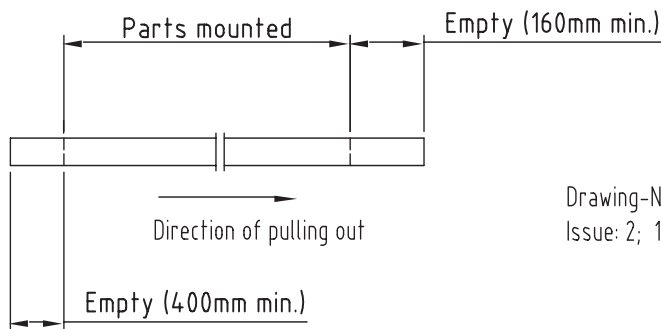

Drawing-No.: 9.800-5080.01-4
Issue: 2; 18.11.02

18033

Taping TEMD1000

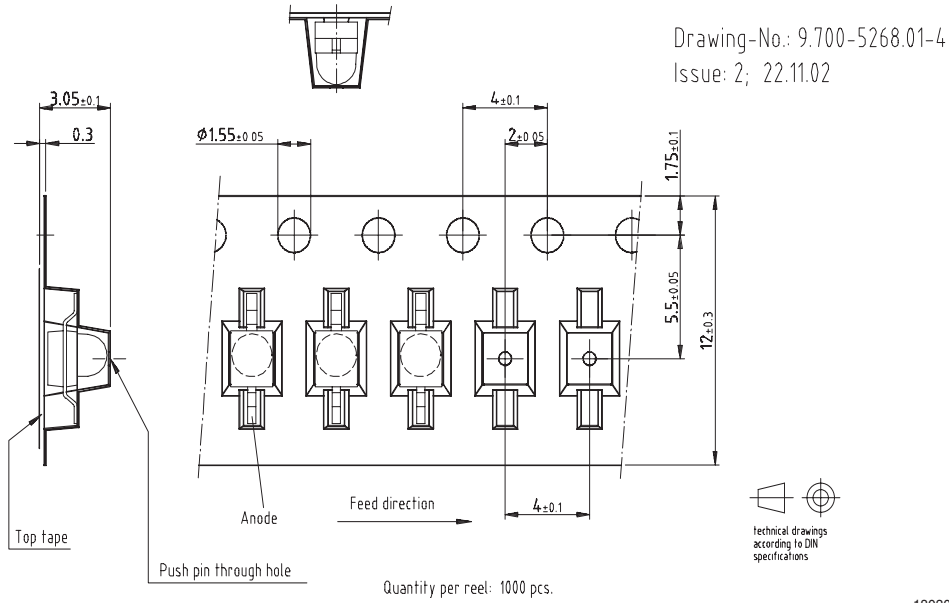

18030

Taping TEMD1020

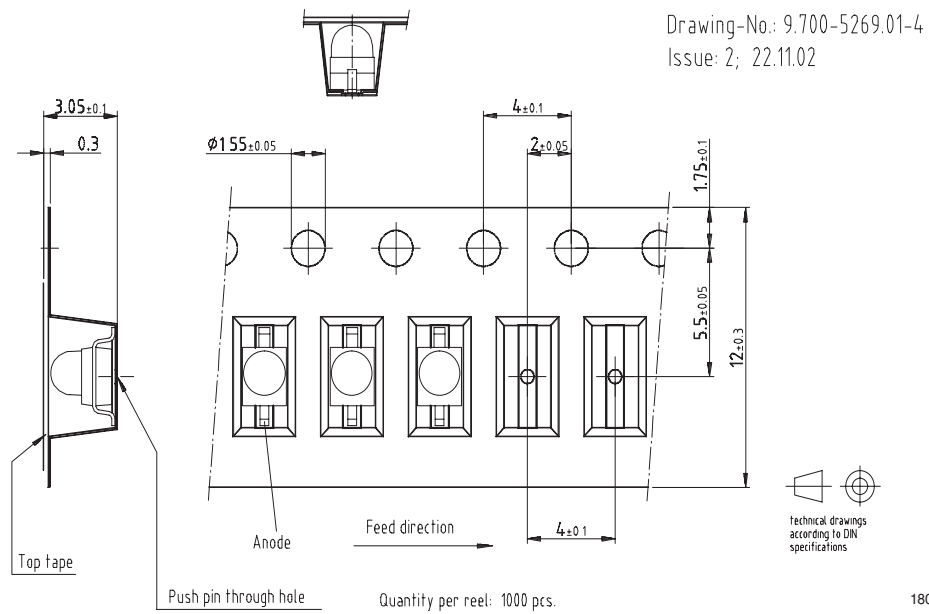

18031

Taping TEMD1030

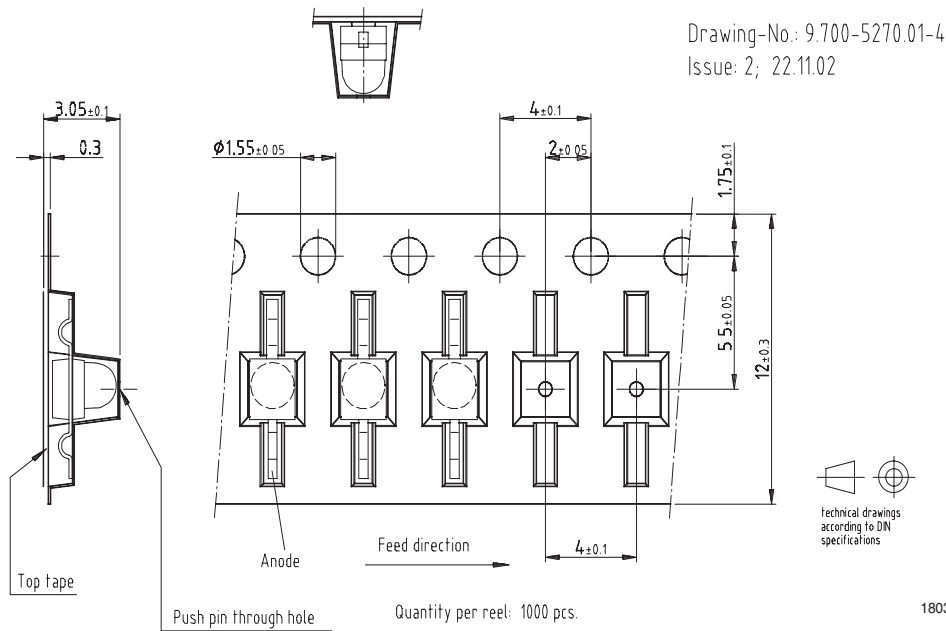

Precautions For Use

1. Over-current-proof

Customer must apply resistors for protection, otherwise slight voltage shift will cause big current change (Burn out will happen).

2. Storage

2.1 Storage temperature and rel. humidity conditions are: 5°C to 35°C , R.H. 60%

2.2 Floor life must not exceed 168 h, acc. to JEDEC level 3, J-STD-020.

Once the package is opened, the products should be used within a week. Otherwise, they should be kept in a damp proof box with desiccant.

Considering tape life, we suggest to use products within one year from production date.

2.3 If opened more than one week in an atmosphere 5°C to 35°C , R.H. 60%, devices should be treated at $60^{\circ}\text{C} \pm 5^{\circ}\text{C}$ for 15 hrs.

2.4 If humidity indicator in the package shows pink color (normal blue), then devices should be treated with the same conditions as 2.3

Reflow Solder Profile

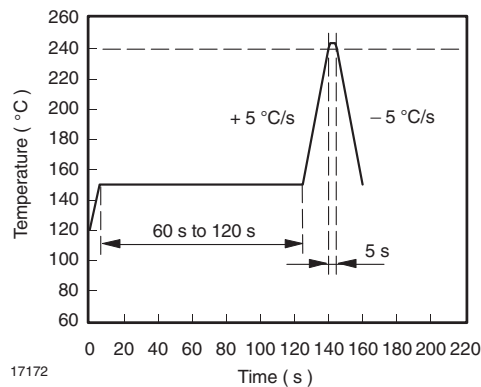



Ozone Depleting Substances Policy Statement

It is the policy of **Vishay Semiconductor GmbH** to

1. Meet all present and future national and international statutory requirements.
2. Regularly and continuously improve the performance of our products, processes, distribution and operating systems with respect to their impact on the health and safety of our employees and the public, as well as their impact on the environment.

It is particular concern to control or eliminate releases of those substances into the atmosphere which are known as ozone depleting substances (ODSs).

The Montreal Protocol (1987) and its London Amendments (1990) intend to severely restrict the use of ODSs and forbid their use within the next ten years. Various national and international initiatives are pressing for an earlier ban on these substances.

Vishay Semiconductor GmbH has been able to use its policy of continuous improvements to eliminate the use of ODSs listed in the following documents.

1. Annex A, B and list of transitional substances of the Montreal Protocol and the London Amendments respectively
2. Class I and II ozone depleting substances in the Clean Air Act Amendments of 1990 by the Environmental Protection Agency (EPA) in the USA
3. Council Decision 88/540/EEC and 91/690/EEC Annex A, B and C (transitional substances) respectively.

Vishay Semiconductor GmbH can certify that our semiconductors are not manufactured with ozone depleting substances and do not contain such substances.

**We reserve the right to make changes to improve technical design
and may do so without further notice.**

Parameters can vary in different applications. All operating parameters must be validated for each customer application by the customer. Should the buyer use Vishay Semiconductors products for any unintended or unauthorized application, the buyer shall indemnify Vishay Semiconductors against all claims, costs, damages, and expenses, arising out of, directly or indirectly, any claim of personal damage, injury or death associated with such unintended or unauthorized use.

Vishay Semiconductor GmbH, P.O.B. 3535, D-74025 Heilbronn, Germany
Telephone: 49 (0)7131 67 2831, Fax number: 49 (0)7131 67 2423