

Small Signal Schottky Barrier Diodes

Features

- Integrated protection ring against static discharge
- Low capacitance
- Low leakage current
- Low forward voltage drop

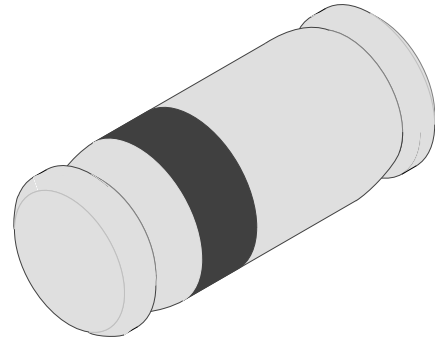

94 9371

Applications

HF–Detector
 Protection circuit
 Diode for low currents with a low supply voltage
 Small battery charger
 Power supplies
 DC / DC converter for notebooks

Order Instruction

Type	Type Differentiation	Ordering Code	Remarks
LL101A	$V_R=60\text{ V}$, $V_F@I_F1\text{mA max. } 0.41\text{ V}$	LL101A–GS08	Tape and Reel
LL101B	$V_R=50\text{ V}$, $V_F@I_F1\text{mA max. } 0.4\text{ V}$	LL101B–GS08	
LL101C	$V_R=40\text{ V}$, $V_F@I_F1\text{mA max. } 0.39\text{ V}$	LL101C–GS08	

Absolute Maximum Ratings

$T_j = 25^\circ\text{C}$

Parameter	Test Conditions	Type	Symbol	Value	Unit
Reverse voltage		LL101A	V_R	60	V
		LL101B	V_R	50	V
		LL101C	V_R	40	V
Peak forward surge current	$t_p=10\mu\text{s}$		I_{FSM}	2	A
Repetitive peak forward current			I_{FRM}	150	mA
Forward current			I_F	30	mA
Junction temperature			T_j	125	$^\circ\text{C}$
Storage temperature range			T_{stg}	–65...+150	$^\circ\text{C}$

Maximum Thermal Resistance

$T_j = 25^\circ\text{C}$

Parameter	Test Conditions	Symbol	Value	Unit
Junction ambient	on PC board 50 mmx50 mmx1.6 mm	R_{thJA}	320	K/W

Electrical Characteristics

$T_j = 25^\circ\text{C}$

Parameter	Test Conditions	Type	Symbol	Min	Typ	Max	Unit
Reverse Breakdown Voltage	$I_R = 10\mu\text{A}$	LL101A	$V_{(BR)R}$	60			V
		LL101B	$V_{(BR)R}$	50			V
		LL101C	$V_{(BR)R}$	40			V
Leakage current	$V_R = 50\text{ V}$	LL101A	I_R			200	nA
	$V_R = 40\text{ V}$	LL101B	I_R			200	nA
	$V_R = 30\text{ V}$	LL101C	I_R			200	nA
Forward voltage drop	$I_F = 1\text{mA}$	LL101A	V_F			0.41	V
		LL101B	V_F			0.4	V
		LL101C	V_F			0.39	V
	$I_F = 15\text{mA}$	LL101A	V_F			1	V
		LL101B	V_F			0.95	V
		LL101C	V_F			0.9	V
Diode capacitance	$V_R = 0\text{ V}, f = 1\text{MHz}$	LL101A	C_D			2.0	pF
		LL101B	C_D			2.1	pF
		LL101C	C_D			2.2	pF

Characteristics ($T_j = 25^\circ\text{C}$ unless otherwise specified)

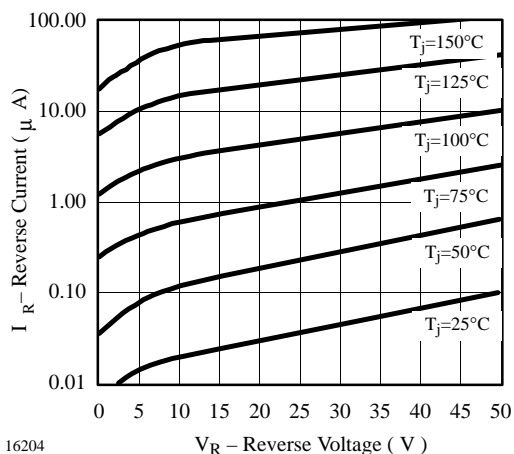

Figure 1. Reverse Current vs. Reverse Voltage

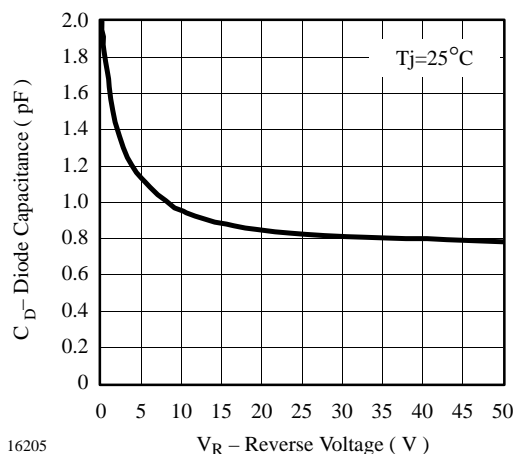

Figure 2. Diode Capacitance vs. Reverse Voltage

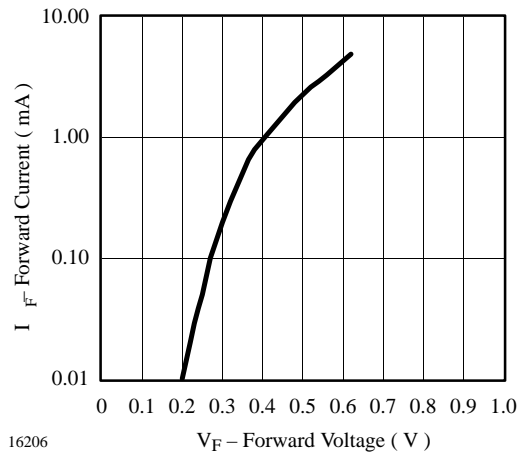
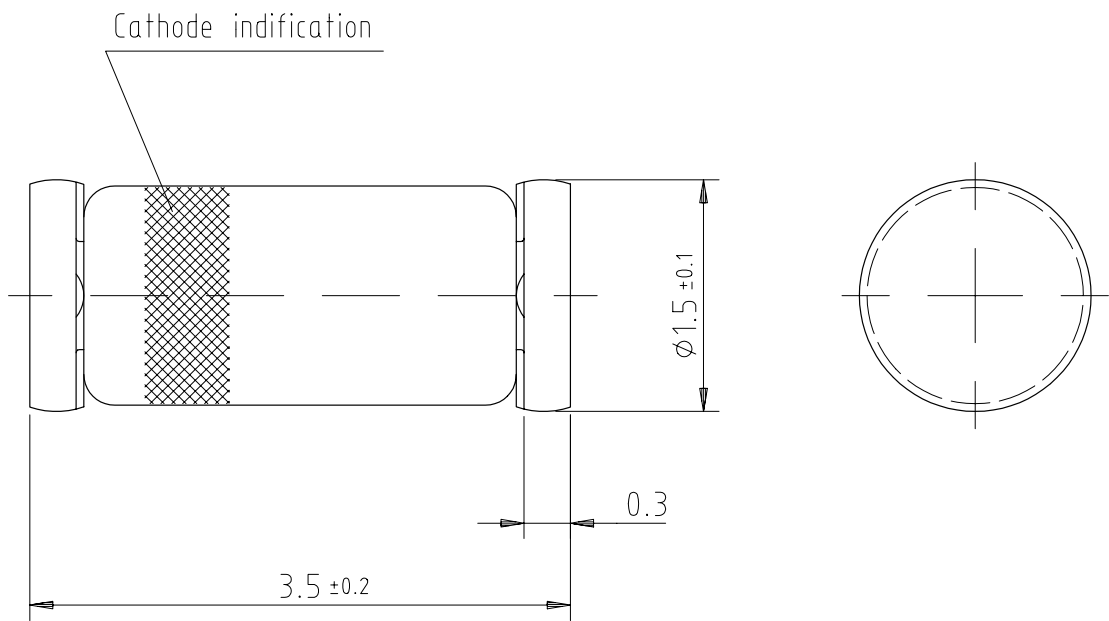

Figure 3. Forward Current vs. Forward Voltage

Dimensions in mm



Glass case
 Mini MELF / SOD 80
 JEDEC DO 213 AA

96 12070

technical drawings
 according to DIN
 specifications

Ozone Depleting Substances Policy Statement

It is the policy of **Vishay Semiconductor GmbH** to

1. Meet all present and future national and international statutory requirements.
2. Regularly and continuously improve the performance of our products, processes, distribution and operating systems with respect to their impact on the health and safety of our employees and the public, as well as their impact on the environment.

It is particular concern to control or eliminate releases of those substances into the atmosphere which are known as ozone depleting substances (ODSs).

The Montreal Protocol (1987) and its London Amendments (1990) intend to severely restrict the use of ODSs and forbid their use within the next ten years. Various national and international initiatives are pressing for an earlier ban on these substances.

Vishay Semiconductor GmbH has been able to use its policy of continuous improvements to eliminate the use of ODSs listed in the following documents.

1. Annex A, B and list of transitional substances of the Montreal Protocol and the London Amendments respectively
2. Class I and II ozone depleting substances in the Clean Air Act Amendments of 1990 by the Environmental Protection Agency (EPA) in the USA
3. Council Decision 88/540/EEC and 91/690/EEC Annex A, B and C (transitional substances) respectively.

Vishay Semiconductor GmbH can certify that our semiconductors are not manufactured with ozone depleting substances and do not contain such substances.

We reserve the right to make changes to improve technical design and may do so without further notice.

Parameters can vary in different applications. All operating parameters must be validated for each customer application by the customer. Should the buyer use Vishay-Semiconductors products for any unintended or unauthorized application, the buyer shall indemnify Vishay-Semiconductors against all claims, costs, damages, and expenses, arising out of, directly or indirectly, any claim of personal damage, injury or death associated with such unintended or unauthorized use.

Vishay Semiconductor GmbH, P.O.B. 3535, D-74025 Heilbronn, Germany
Telephone: 49 (0)7131 67 2831, Fax number: 49 (0)7131 67 2423