

1 Form B Solid State Relay

Features

- Isolation Test Voltage 3750 V_{RMS}
- Typical R_{ON} 20 Ω
- Load Voltage 350 V
- Clean Bounce Free Switching
- Low Power Consumption
- SMD Lead Available on Tape and Reel
- Lead (Pb)-free component
- Component in accordance to RoHS 2002/95/EC and WEEE 2002/96/EC

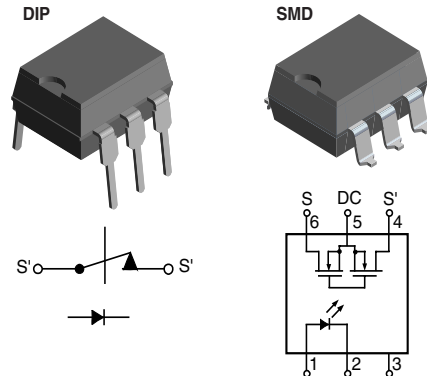

Agency Approvals

- UL1577, File No. E52744 System Code H or J, Double Protection
- CSA - Certification 093751

Applications

- General Telecom Switching
- Security Equipment
- Instrumentation
- Industrial Controls

Description

The LH1501 relays are SPST normally closed switches (1 Form B) that can replace electromechanical relays in many applications. The relays are constructed as a mult.-chip hybrid device. Actuation control is via an Infrared LED. The output switch is a combination of a photodiode array with MOSFET switches and control circuitry. The relays can be configured for AC/DC or DC only operation.

Order Information

Part	Remarks
LH1501BAB	Tubes, SMD-6
LH1501BABTR	Tape and Reel, SMD-6
LH1501BT	Tubes, DIP-6

Absolute Maximum Ratings, T_{amb} = 25 °C

Stresses in excess of the absolute Maximum Ratings can cause permanent damage to the device. Functional operation of the device is not implied at these or any other conditions in excess of those given in the operational sections of this document. Exposure to absolute Maximum Ratings for extended periods of time can adversely affect reliability.

SSR

Parameter	Test condition	Symbol	Value	Unit
LED continuous forward current		I _F	50	mA
LED reverse voltage	I _R ≤ 10 μA	V _R	5.0	V
DC or peak AC load voltage	I _L ≤ 50 μA	V _L	350	V
Continuous DC load current - bidirectional operation		I _L	150	mA
Continuous DC load current - unidirectional operation		I _L	200	mA
Peak load current (single shot)	t = 100 ms	I _P	350	mA

Parameter	Test condition	Symbol	Value	Unit
Ambient temperature range		T_{amb}	- 40 to + 85	°C
Storage temperature range		T_{stg}	- 40 to + 125	°C
Pin soldering temperature	$t = 10 \text{ s max}$	T_{sld}	260	°C
Input/output isolation voltage	$t = 1.0 \text{ s}, I_{ISO} = 10 \mu\text{A max}$	V_{ISO}	3750	V_{RMS}
Output power dissipation (continuous)		P_{diss}	550	mW

Electrical Characteristics, $T_{amb} = 25 \text{ °C}$

Minimum and maximum values are testing requirements. Typical values are characteristics of the device and are the result of engineering evaluations. Typical values are for information only and are not part of the testing requirements.

Input

Parameter	Test condition	Symbol	Min	Typ.	Max	Unit
LED forward current, switch turn-on	$I_L = \pm 150 \text{ mA}, t = 10 \text{ ms}$	I_{Fon}	0.2	0.9		mA
LED forward current, switch turn-off	$V_L = \pm 300 \text{ V}$	I_{Foff}		1.0	2.0	mA
LED forward voltage	$I_F = 10 \text{ mA}$	V_F	1.15	1.26	1.45	V

Output

Parameter	Test condition	Symbol	Min	Typ.	Max	Unit
ON-resistance ac/dc: Pin 4, 6 (+) to 5 (-)	$I_F = 0 \text{ mA}, I_L = 50 \text{ mA}$	R_{ON}		20	25	Ω
ON-resistance dc: Pin 4, 6 (+) to 5 (-)	$I_F = 0 \text{ mA}, I_L = 100 \text{ mA}$	R_{ON}		5.0	6.25	Ω
OFF-resistance	$I_F = 5.0 \text{ mA}, V_L = \pm 100 \text{ V}$	R_{OFF}	0.1	1.4		$G\Omega$
Off-state leakage current	$I_F = 5.0 \text{ mA}, V_L = \pm 350 \text{ V}$	I_O		0.08	1.0	μA
Output capacitance	$I_F = 5.0 \text{ mA}, V_L = 50 \text{ V}$	C_O		35		pF

Transfer

Parameter	Test condition	Symbol	Min	Typ.	Max	Unit
Capacitance (input-output)	$V_{ISO} = 1.0 \text{ V}$	C_{IO}		3.0		pF
Turn-on time	$I_F = 5.0 \text{ mA}, I_L = 50 \text{ mA}$	t_{on}		2.0	3.0	ms
Turn-off time	$I_F = 5.0 \text{ mA}, I_L = 50 \text{ mA}$	t_{off}		1.0	3.0	ms

Typical Characteristics (Tamb = 25 °C unless otherwise specified)

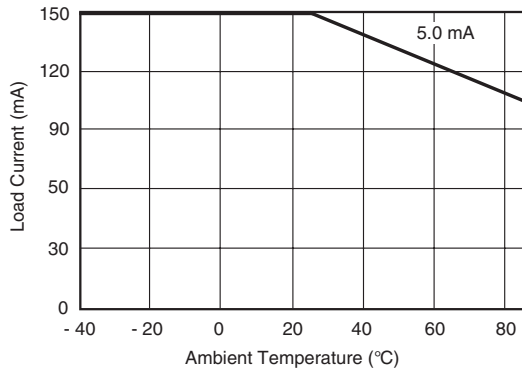

ih1501bt_00

Figure 1. Recommended Operating Conditions

Package Dimensions in Inches (mm)

DIP

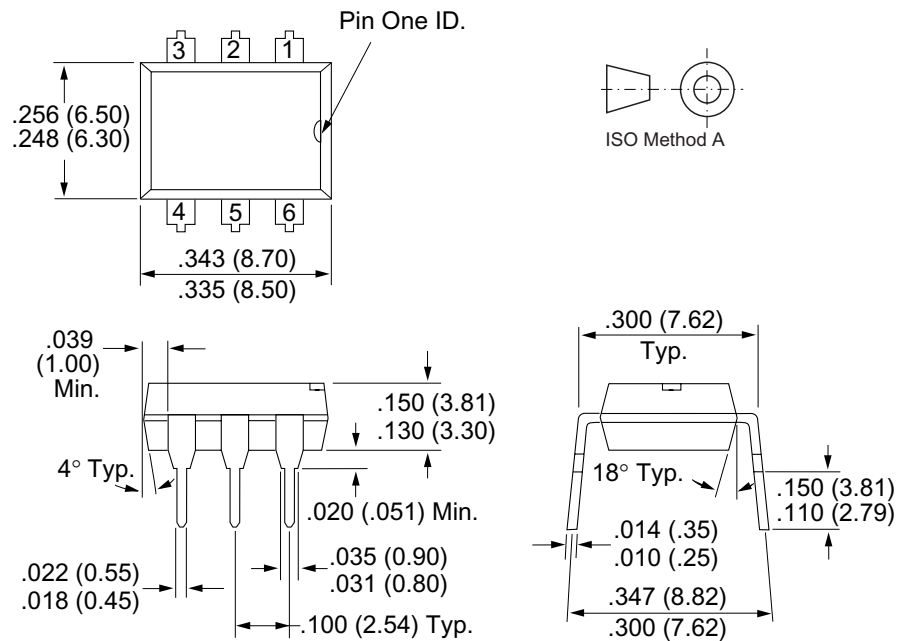

LH1501BAB/ BABTR/ BT



Vishay Semiconductors

Package Dimensions in Inches (mm)

SMD

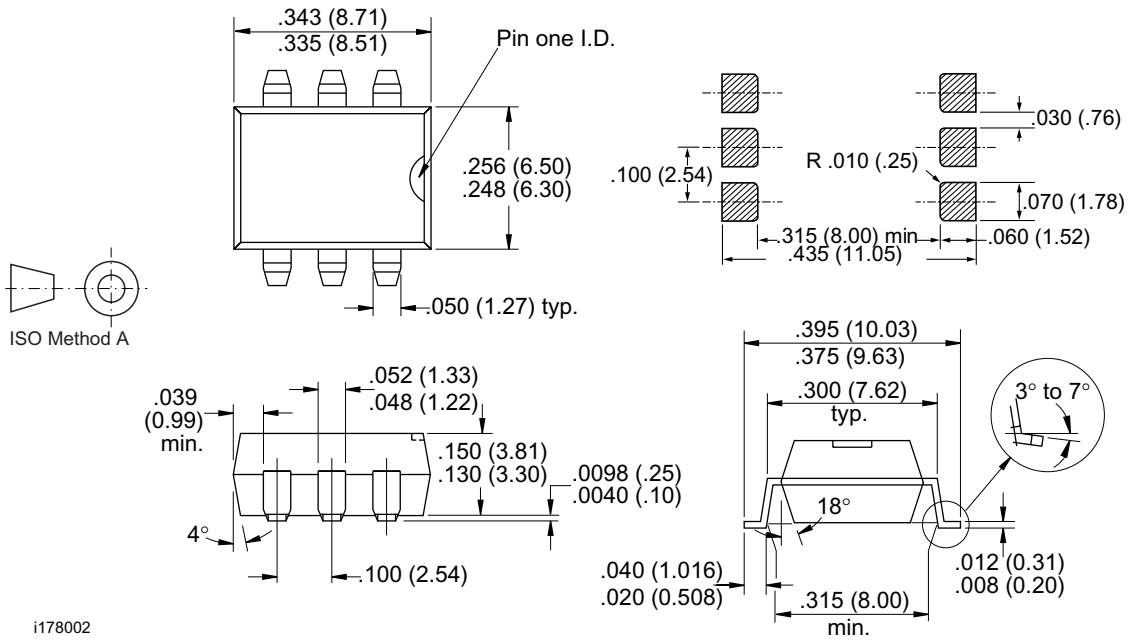



Ozone Depleting Substances Policy Statement

It is the policy of Vishay Semiconductor GmbH to

1. Meet all present and future national and international statutory requirements.
2. Regularly and continuously improve the performance of our products, processes, distribution and operating systems with respect to their impact on the health and safety of our employees and the public, as well as their impact on the environment.

It is particular concern to control or eliminate releases of those substances into the atmosphere which are known as ozone depleting substances (ODSs).

The Montreal Protocol (1987) and its London Amendments (1990) intend to severely restrict the use of ODSs and forbid their use within the next ten years. Various national and international initiatives are pressing for an earlier ban on these substances.

Vishay Semiconductor GmbH has been able to use its policy of continuous improvements to eliminate the use of ODSs listed in the following documents.

1. Annex A, B and list of transitional substances of the Montreal Protocol and the London Amendments respectively
2. Class I and II ozone depleting substances in the Clean Air Act Amendments of 1990 by the Environmental Protection Agency (EPA) in the USA
3. Council Decision 88/540/EEC and 91/690/EEC Annex A, B and C (transitional substances) respectively.

Vishay Semiconductor GmbH can certify that our semiconductors are not manufactured with ozone depleting substances and do not contain such substances.

We reserve the right to make changes to improve technical design and may do so without further notice.

Parameters can vary in different applications. All operating parameters must be validated for each customer application by the customer. Should the buyer use Vishay Semiconductors products for any unintended or unauthorized application, the buyer shall indemnify Vishay Semiconductors against all claims, costs, damages, and expenses, arising out of, directly or indirectly, any claim of personal damage, injury or death associated with such unintended or unauthorized use.

Vishay Semiconductor GmbH, P.O.B. 3535, D-74025 Heilbronn, Germany



Disclaimer

All product specifications and data are subject to change without notice.

Vishay Intertechnology, Inc., its affiliates, agents, and employees, and all persons acting on its or their behalf (collectively, "Vishay"), disclaim any and all liability for any errors, inaccuracies or incompleteness contained herein or in any other disclosure relating to any product.

Vishay disclaims any and all liability arising out of the use or application of any product described herein or of any information provided herein to the maximum extent permitted by law. The product specifications do not expand or otherwise modify Vishay's terms and conditions of purchase, including but not limited to the warranty expressed therein, which apply to these products.

No license, express or implied, by estoppel or otherwise, to any intellectual property rights is granted by this document or by any conduct of Vishay.

The products shown herein are not designed for use in medical, life-saving, or life-sustaining applications unless otherwise expressly indicated. Customers using or selling Vishay products not expressly indicated for use in such applications do so entirely at their own risk and agree to fully indemnify Vishay for any damages arising or resulting from such use or sale. Please contact authorized Vishay personnel to obtain written terms and conditions regarding products designed for such applications.

Product names and markings noted herein may be trademarks of their respective owners.