



# Multichannel Optocoupler with Phototransistor Output

## Description

The CNY74-2H and CNY74-4H consist of a phototransistor optically coupled to a gallium arsenide infrared-emitting diode in an 8-lead, resp. 16-lead plastic dual in line package.

The elements are mounted on one leadframe using a **coplanar technique**, providing a fixed distance between input and output for highest safety requirements.

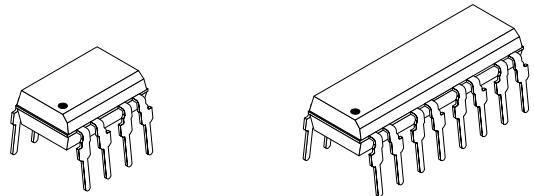

14926

## Applications

Galvanically separated circuits, non-interacting switches

## Features

- CNY74-2H includes 2 isolater channels
- CNY74-4H includes 4 isolater channels
- Isolation test voltage  $V_{IO} = 5 \text{ kV}$
- Test class 25/100/21 DIN 40 045
- Low coupling capacitance of typical 0.3 pF
- **Current Transfer Ratio (CTR)** of typical 100%
- Low temperature coefficient of CTR
- Wide ambient temperature range
- **Underwriters Laboratory (UL) 1577** recognized, file number E-76222
- **CSA (C-UL) 1577** recognized, file number E-76222 – Double Protection
- Coupling System U

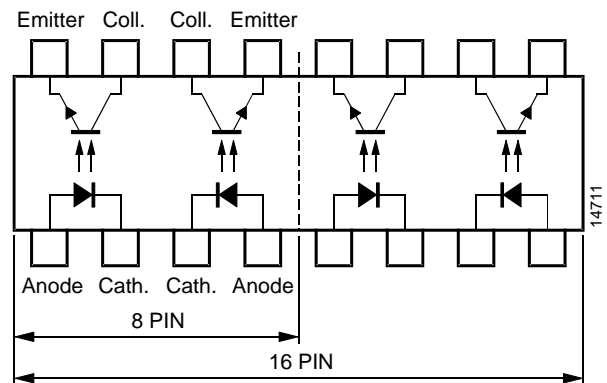

## Order Instruction

Ordering Code	CTR Ranking	Remarks
CNY74-2H	50 to 600%	8 Pin = Dual channel
CNY74-4H	50 to 600%	16 Pin = Quad channel



### Absolute Maximum Ratings

#### Input (Emitter)

Parameter	Test Conditions	Symbol	Value	Unit
Reverse voltage		$V_R$	6	V
Forward current		$I_F$	60	mA
Forward surge current	$t_p \leq 10\mu\text{s}$	$I_{FSM}$	1.5	A
Power dissipation	$T_{amb} \leq 25^\circ\text{C}$	$P_V$	100	mW
Junction temperature		$T_j$	125	$^\circ\text{C}$

#### Output (Detector)

Parameter	Test Conditions	Symbol	Value	Unit
Collector emitter voltage		$V_{CEO}$	70	V
Emitter collector voltage		$V_{ECO}$	7	V
Collector current		$I_C$	50	mA
Peak collector current	$t_p/T = 0.5, t_p \leq 10\text{ ms}$	$I_{CM}$	100	mA
Power dissipation	$T_{amb} \leq 25^\circ\text{C}$	$P_V$	150	mW
Junction temperature		$T_j$	125	$^\circ\text{C}$

#### Coupler

Parameter	Test Conditions	Symbol	Value	Unit
AC isolation test voltage (RMS)	$t = 1\text{ min}$	$V_{IO}^{1)}$	5	kV
Total power dissipation	$T_{amb} \leq 25^\circ\text{C}$	$P_{tot}$	250	mW
Ambient temperature range		$T_{amb}$	-40 to +100	$^\circ\text{C}$
Storage temperature range		$T_{stg}$	-55 to +125	$^\circ\text{C}$
Soldering temperature	2 mm from case, $t \leq 10\text{ s}$	$T_{sd}$	260	$^\circ\text{C}$

<sup>1)</sup> Related to standard climate 23/50 DIN 50014



**Electrical Characteristics** ( $T_{amb} = 25^{\circ}\text{C}$ )

Input (Emitter)

Parameter	Test Conditions	Symbol	Min.	Typ.	Max.	Unit
Forward voltage	$I_F = 50 \text{ mA}$	$V_F$		1.25	1.6	V

Output (Detector)

Parameter	Test Conditions	Symbol	Min.	Typ.	Max.	Unit
Collector emitter voltage	$I_C = 1 \text{ mA}$	$V_{CEO}$	70			V
Emitter collector voltage	$I_E = 100 \mu\text{A}$	$V_{ECO}$	7			V
Collector dark current	$V_{CE} = 20 \text{ V}, I_F = 0, E = 0$	$I_{CEO}$			100	nA

Coupler

Parameter	Test Conditions	Symbol	Min.	Typ.	Max.	Unit
DC isolation test voltage	$t = 2 \text{ s}$	$V_{IO}^{1)}$	5			kV
Isolation resistance	$V_{IO} = 1000 \text{ V},$ 40% relative humidity	$R_{IO}^{1)}$		$10^{12}$		$\Omega$
Collector emitter saturation voltage	$I_F = 10 \text{ mA}, I_C = 1 \text{ mA}$	$V_{CEsat}$			0.3	V
Cut-off frequency	$V_{CE} = 5 \text{ V}, I_F = 10 \text{ mA},$ $R_L = 100 \Omega$	$f_c$		100		kHz
Coupling capacitance	$f = 1 \text{ MHz}$	$C_k$		0.3		pF

<sup>1)</sup> Related to standard climate 23/50 DIN 50014

Current Transfer Ratio (CTR)

Parameter	Test Conditions	Type	Symbol	Min.	Typ.	Max.	Unit
$I_C/I_F$	$V_{CE} = 5 \text{ V}, I_F = 5 \text{ mA}$		CTR	0.5	1.0	6.0	
	$V_{CE} = 5 \text{ V}, I_F = 10 \text{ mA}$		CTR	0.6	1.2		

## Switching Characteristics

Parameter	Test Conditions	Symbol	Typ.	Unit
Delay time	$V_S = 5\text{ V}$ , $I_C = 2\text{ mA}$ , $R_L = 100\ \Omega$ (see figure 1)	$t_d$	3.0	$\mu\text{s}$
Rise time		$t_r$	3.0	$\mu\text{s}$
Fall time		$t_f$	4.7	$\mu\text{s}$
Storage time		$t_s$	0.3	$\mu\text{s}$
Turn-on time	$V_S = 5\text{ V}$ , $I_F = 10\text{ mA}$ , $R_L = 1\text{ k}\Omega$ (see figure 2)	$t_{on}$	6.0	$\mu\text{s}$
Turn-off time		$t_{off}$	5.0	$\mu\text{s}$
Turn-on time	$V_S = 5\text{ V}$ , $I_F = 10\text{ mA}$ , $R_L = 1\text{ k}\Omega$ (see figure 2)	$t_{on}$	9.0	$\mu\text{s}$
Turn-off time		$t_{off}$	18.0	$\mu\text{s}$

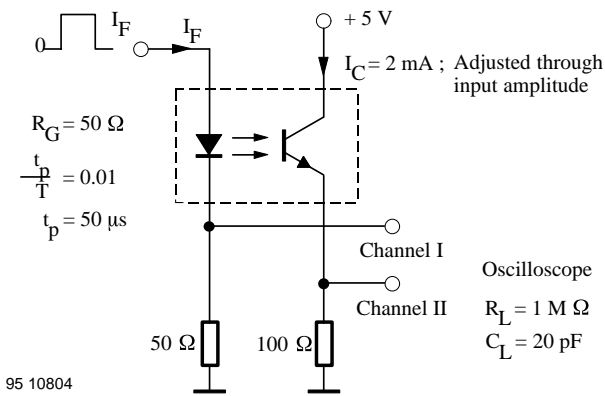

Figure 1. Test circuit, non-saturated operation

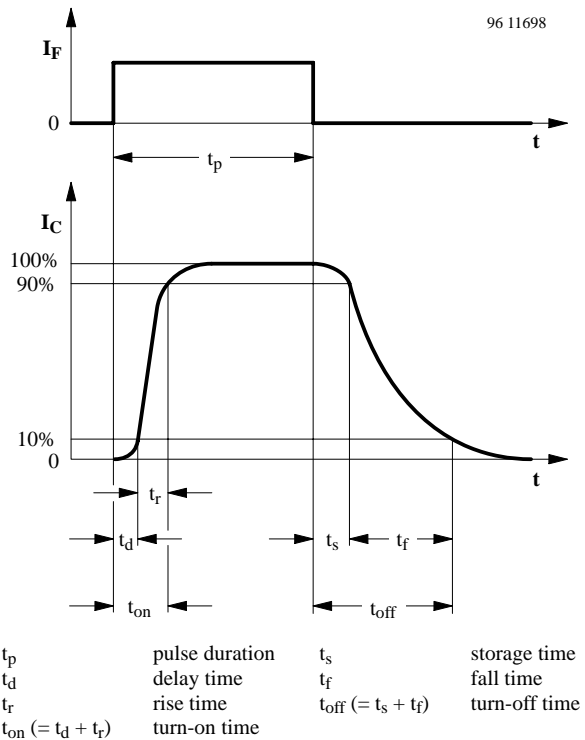

Figure 3. Switching times

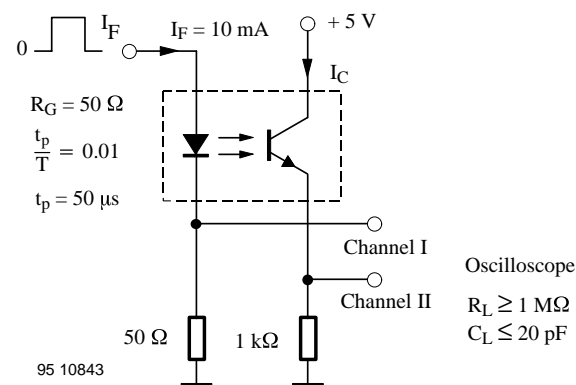

Figure 2. Test circuit, saturated operation



**Typical Characteristics** ( $T_{amb} = 25^{\circ}\text{C}$ , unless otherwise specified)

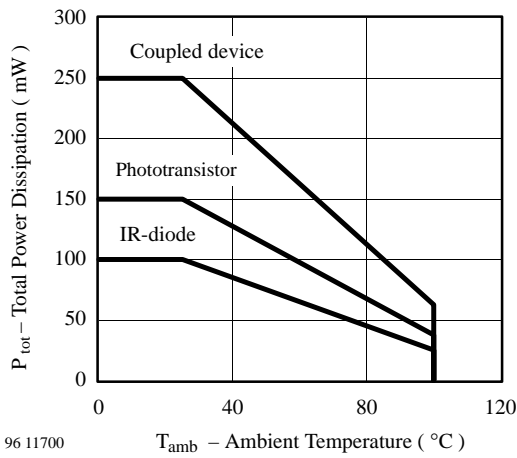

Figure 4. Total Power Dissipation vs. Ambient Temperature

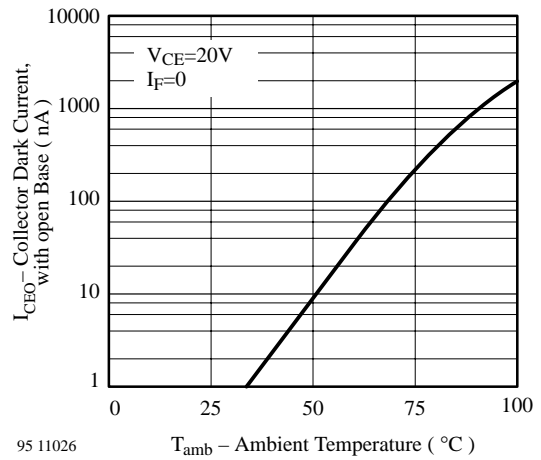

Figure 7. Collector Dark Current vs. Ambient Temperature

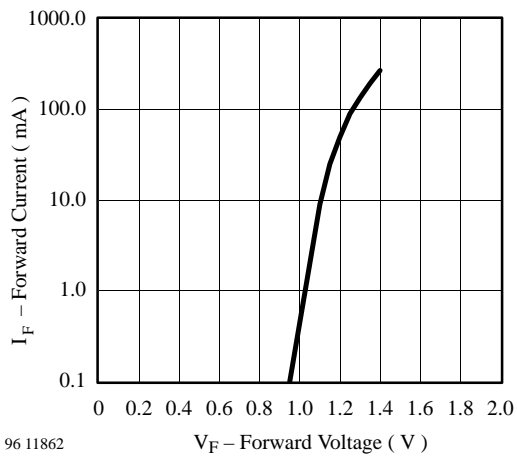

Figure 5. Forward Current vs. Forward Voltage

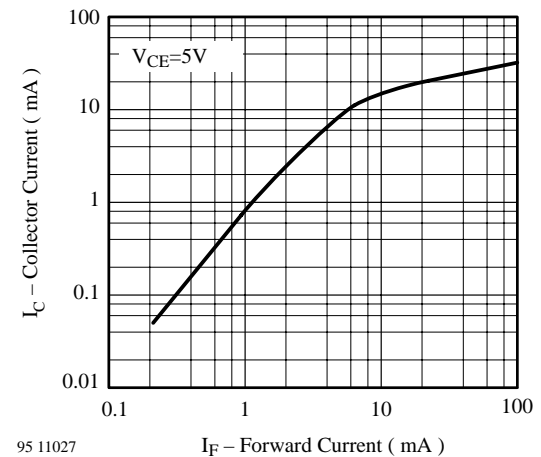

Figure 8. Collector Current vs. Forward Current

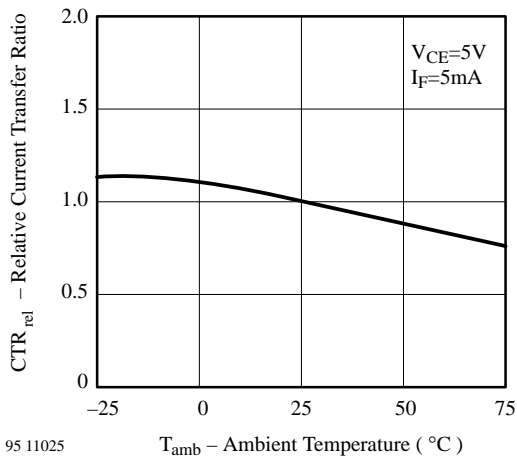

Figure 6. Relative Current Transfer Ratio vs. Ambient Temperature

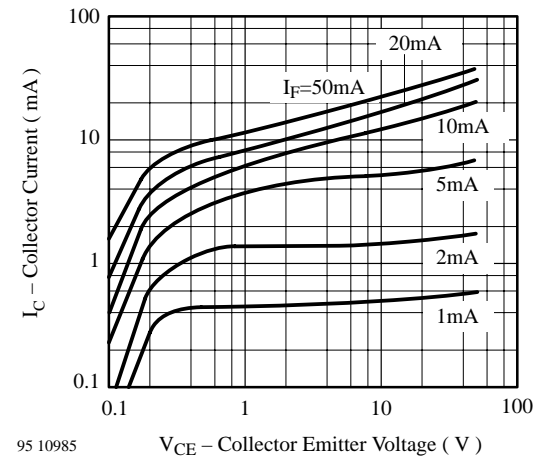

Figure 9. Collector Current vs. Collector Emitter Voltage

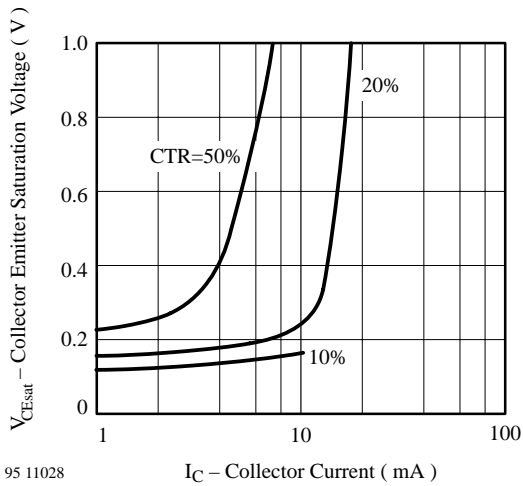

Figure 10. Collector Emitter Saturation Voltage vs. Collector Current

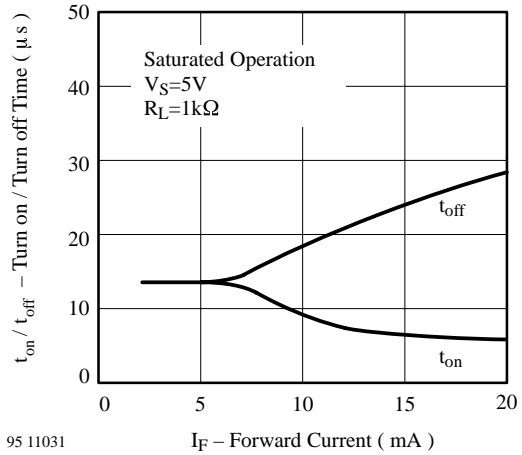

Figure 12. Turn on / off Time vs. Forward Current

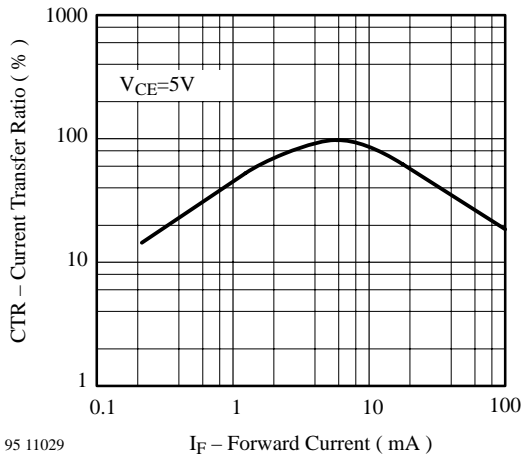

Figure 11. Current Transfer Ratio vs. Forward Current

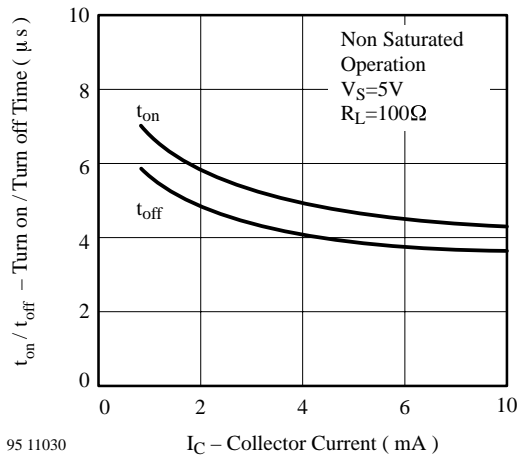
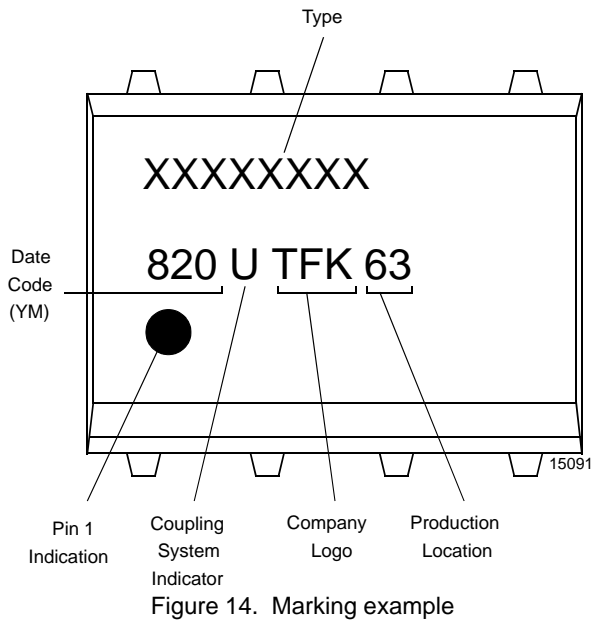
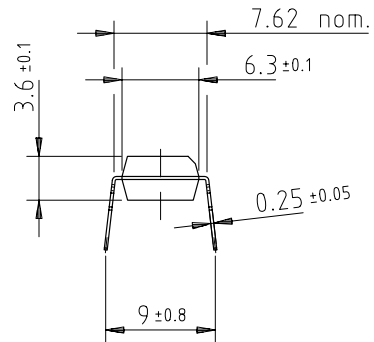
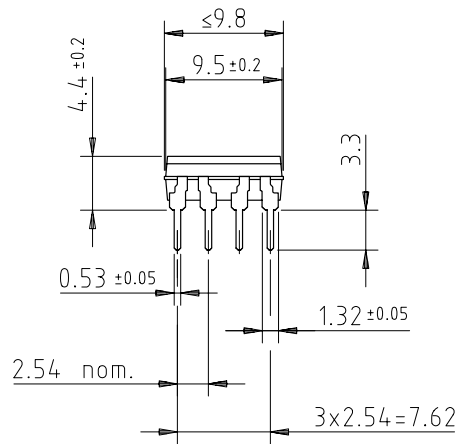

Figure 13. Turn on / off Time vs. Collector Current



## Dimensions of CNY74-2 in mm



weight: ca. 0.55 g  
 creepage distance:  $\geq 6$  mm  
 air path:  $\geq 6$  mm

after mounting on PC board

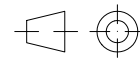
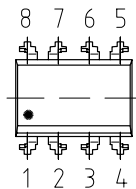

technical drawings  
 according to DIN  
 specifications

14784

# CNY74-2H/ CNY74-4H

Vishay Semiconductors



## Dimensions of CNY74-4 in mm

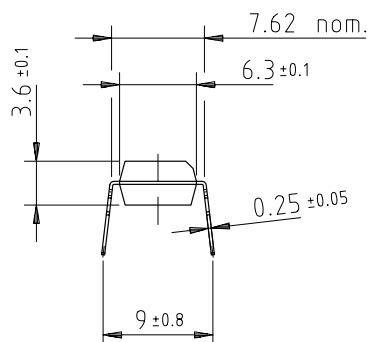
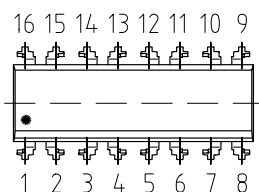
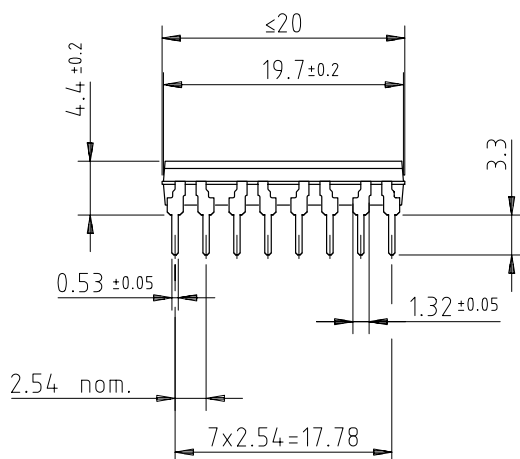

weight: ca. 1.0 g  
creepage distance:  $\cong 6$  mm  
air path:  $\cong 6$  mm

after mounting on PC board

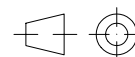

technical drawings  
according to DIN  
specifications

14783



## **Ozone Depleting Substances Policy Statement**

It is the policy of **Vishay Semiconductor GmbH** to

1. Meet all present and future national and international statutory requirements.
2. Regularly and continuously improve the performance of our products, processes, distribution and operating systems with respect to their impact on the health and safety of our employees and the public, as well as their impact on the environment.

It is particular concern to control or eliminate releases of those substances into the atmosphere which are known as ozone depleting substances (ODSs).

The Montreal Protocol (1987) and its London Amendments (1990) intend to severely restrict the use of ODSs and forbid their use within the next ten years. Various national and international initiatives are pressing for an earlier ban on these substances.

**Vishay Semiconductor GmbH** has been able to use its policy of continuous improvements to eliminate the use of ODSs listed in the following documents.

1. Annex A, B and list of transitional substances of the Montreal Protocol and the London Amendments respectively
2. Class I and II ozone depleting substances in the Clean Air Act Amendments of 1990 by the Environmental Protection Agency (EPA) in the USA
3. Council Decision 88/540/EEC and 91/690/EEC Annex A, B and C (transitional substances) respectively.

**Vishay Semiconductor GmbH** can certify that our semiconductors are not manufactured with ozone depleting substances and do not contain such substances.

**We reserve the right to make changes to improve technical design and may do so without further notice.**

Parameters can vary in different applications. All operating parameters must be validated for each customer application by the customer. Should the buyer use Vishay Semiconductors products for any unintended or unauthorized application, the buyer shall indemnify Vishay Semiconductors against all claims, costs, damages, and expenses, arising out of, directly or indirectly, any claim of personal damage, injury or death associated with such unintended or unauthorized use.

Vishay Semiconductor GmbH, P.O.B. 3535, D-74025 Heilbronn, Germany  
Telephone: 49 (0) 7131 67 2831, Fax number: 49 (0) 7131 67 2423