



BYM12-50 thru BYM12-400, EGL41A thru EGL41G

Vishay Semiconductors
formerly General Semiconductor

Surface Mount Glass Passivated Ultrafast Rectifier

Reverse Voltage 50 to 400V
Forward Current 1.0A



DO-213AB

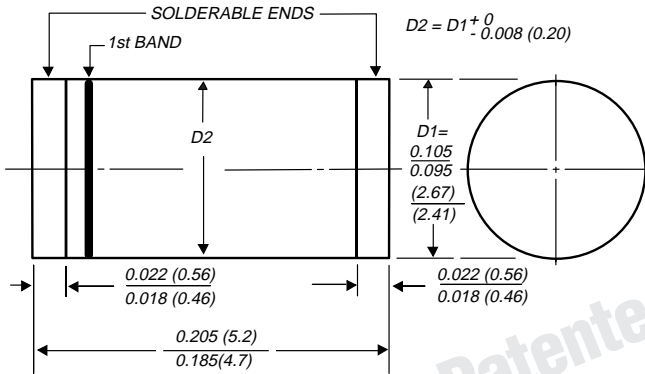

1st band denotes type and positive end (cathode)



Patented*

Dimensions in inches and (millimeters)

* Glass-plastic encapsulation is covered by Patent No. 3,996,602 and brazed-lead assembly to Patent No. 3,930,306

Features

- Plastic package has Underwriters Laboratories Flammability Classification 94V-0
- Capable of meeting environmental standards of MIL-S-19500
- High temperature metallurgically bonded construction
- Cavity-free glass passivated junction
- Fast switching for high efficiency
- High temperature soldering guaranteed: 450°C/5 seconds at terminals. Complete device submersible temperature of 260°C for 10 seconds in solder bath

Mechanical Data

Case: JEDEC DO-213AB, molded plastic over glass body

Terminals: Plated terminals, solderable per MIL-STD-750, Method 2026

Polarity: Two bands indicate cathode end – 1st band denotes device type and 2nd band denotes repetitive peak reverse voltage rating

Mounting Position: Any **Weight:** 0.0046 oz., 0.13 g

Maximum Ratings & Thermal Characteristics Ratings at 25°C ambient temperature unless otherwise specified.

Parameter	Symbol	BYM12-50	BYM12-100	BYM12-150	BYM12-200	BYM12-300	BYM12-400	Unit
Fast efficient device: 1st band is Green		EGL41A	EGL41B	EGL41C	EGL41D	EGL41F	EGL41G	
Polarity color bands (2nd Band)		Gray	Red	Pink	Orange	Brown	Yellow	
Maximum repetitive peak reverse voltage	V _{RRM}	50	100	150	200	300	400	V
Maximum RMS voltage	V _{RMS}	35	70	105	140	210	280	V
Maximum DC blocking voltage	V _{DC}	50	100	150	200	300	400	V
Maximum average forward rectified current at T _T = 75°C	I _{F(AV)}	1.0						A
Peak forward surge current 8.3ms single half sine-wave superimposed on rated load (JEDEC Method)	I _{FSM}	30						A
Maximum thermal resistance (Note 1, 2)	R _{θJA} R _{θJT}	60 30						°C/W
Operating junction and storage temperature range	T _J , T _{STG}	-65 to +175						°C

Electrical Characteristics Ratings at 25°C ambient temperature unless otherwise specified.

Parameter	Symbol	BYM12-50	BYM12-100	BYM12-150	BYM12-200	BYM12-300	BYM12-400	Unit
		EGL41A	EGL41B	EGL41C	EGL41D	EGL41F	EGL41G	
Maximum instantaneous forward voltage at 1.0A	V _F	1.0				1.25		V
Maximum DC reverse current at rated DC blocking voltage T _A = 25°C T _A = 125°C	I _R	5.0 50						μA
Max. reverse recovery time at I _F = 0.5A, I _R = 1.0A, I _r = 0.25A	t _{rr}	50						ns
Typical junction capacitance at 4.0V, 1MHz	C _J	20				14		pF

Notes: (1) Thermal resistance from junction to ambient, 0.24 x 0.24" (6.0 x 6.0mm) copper pads to each terminal
(2) Thermal resistance from junction to terminal, 0.24 x 0.24" (6.0 x 6.0mm) copper pads to each terminal

Vishay Semiconductors
formerly General Semiconductor

Ratings and Characteristic Curves ($T_A = 25^\circ\text{C}$ unless otherwise noted)

Fig. 1 – Maximum Forward Current Derating Curve

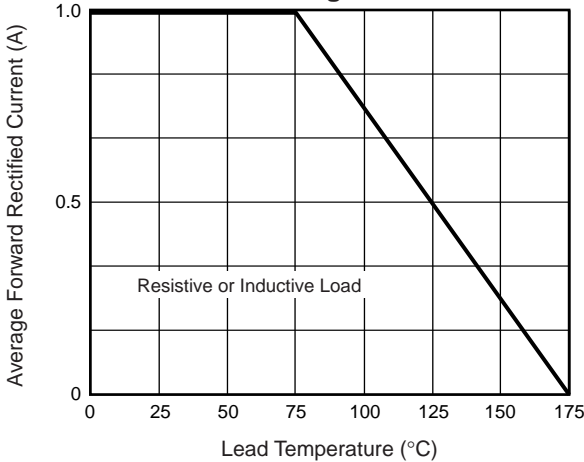

Fig. 2 – Maximum Non-Repetitive Peak Forward Surge Current

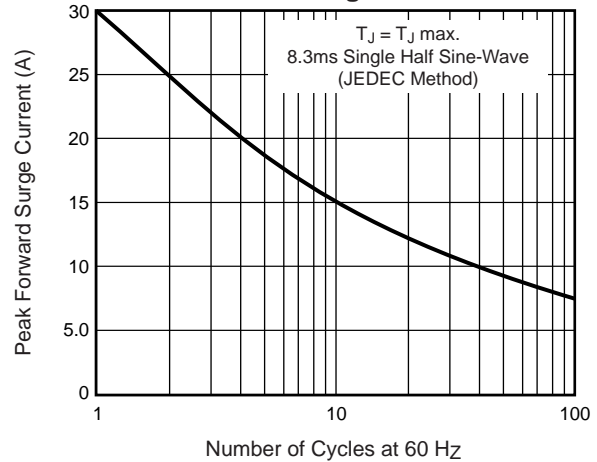

Fig. 3 – Typical Instantaneous Forward Characteristics

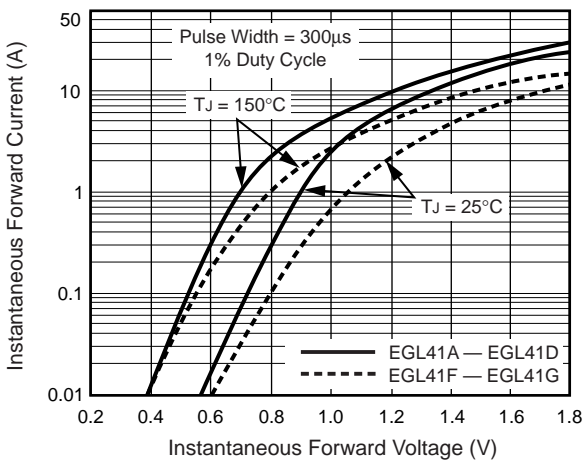

Fig. 4 – Typical Reverse Leakage Characteristics

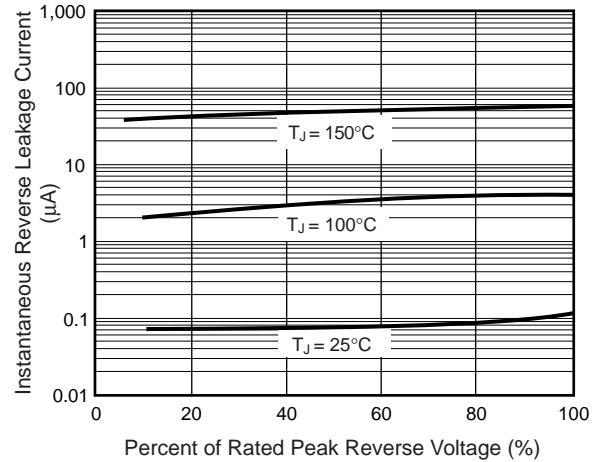

Fig. 5 – Typical Junction Capacitance

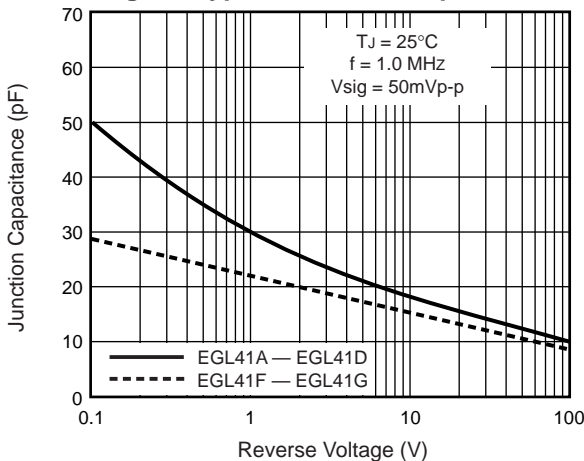

Fig. 6 – Typical Transient Thermal Impedance

