

Switching Diode

Features

- Silicon Epitaxial Planar Diodes
- Saving space
- Hermetic sealed parts
- Fits onto SOD 323 / SOT 23 footprints
- Electrical data identical with the devices BAV100...BAV103 / BAV200...BAV203

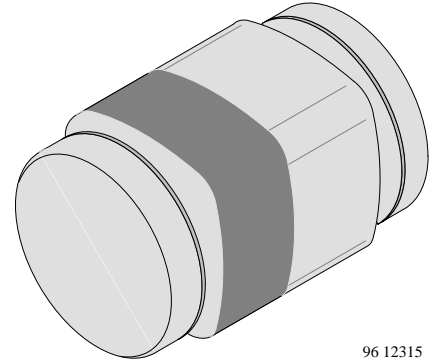

96 12315

Applications

General purposes

Order Instruction

Type	Type Differentiation	Ordering Code	Remarks
BAV300	$V_{RRM} = 60 \text{ V}$	BAV300-TR	Tape and Reel
BAV301	$V_{RRM} = 120 \text{ V}$	BAV301-TR	Tape and Reel
BAV302	$V_{RRM} = 200 \text{ V}$	BAV302-TR	Tape and Reel
BAV303	$V_{RRM} = 250 \text{ V}$	BAV303-TR	Tape and Reel

Absolute Maximum Ratings

$T_j = 25^\circ\text{C}$

Parameter	Test Conditions	Type	Symbol	Value	Unit
Peak reverse voltage		BAV300	V_{RRM}	60	V
		BAV301		120	V
		BAV302		200	V
		BAV303		250	V
Reverse voltage		BAV300	V_R	50	V
		BAV301		100	V
		BAV302		150	V
		BAV303		200	V
Forward current			I_F	250	mA
Peak forward surge current	$t_p=1\text{s}, T_j=25^\circ\text{C}$		I_{FSM}	1	A
Forward peak current	$f=50\text{Hz}$		I_{FM}	625	mA
Junction temperature			T_j	175	$^\circ\text{C}$
Storage temperature range			T_{stg}	-65...+175	$^\circ\text{C}$

Maximum Thermal Resistance

$T_j = 25^\circ\text{C}$

Parameter	Test Conditions	Symbol	Value	Unit
Junction ambient	mounted on epoxy-glass hard tissue, Fig. 1 35 μm copper clad, 0.9 mm ² copper area per electrode	R_{thJA}	500	K/W

Electrical Characteristics

$T_j = 25^\circ\text{C}$

Parameter	Test Conditions	Type	Symbol	Min	Typ	Max	Unit
Forward voltage	$I_F=100\text{mA}$		V_F			1	V
Reverse current	$V_R=50\text{ V}$	BAV300	I_R			100	nA
	$V_R=100\text{ V}$	BAV301	I_R			100	nA
	$V_R=150\text{ V}$	BAV302	I_R			100	nA
	$V_R=200\text{ V}$	BAV303	I_R			100	nA
	$T_j=100^\circ\text{C}, V_R=50\text{ V}$	BAV300	I_R			15	μA
	$T_j=100^\circ\text{C}, V_R=100\text{ V}$	BAV301	I_R			15	μA
	$T_j=100^\circ\text{C}, V_R=150\text{ V}$	BAV302	I_R			15	μA
	$T_j=100^\circ\text{C}, V_R=200\text{ V}$	BAV303	I_R			15	μA
Breakdown voltage	$I_R=100\mu\text{A}, t_p/T=0.01, t_p=0.3\text{ms}$	BAV300	$V_{(BR)}$	60			V
		BAV301		120			V
		BAV302		200			V
		BAV303		250			V
Diode capacitance	$V_R=0, f=1\text{MHz}$		C_D		1.5		pF
Differential forward resistance	$I_F=10\text{mA}$		r_f		5		Ω
Reverse recovery time	$I_F=I_R=30\text{mA}, i_R=3\text{mA}, R_L=100\Omega$		t_{rr}			50	ns

Characteristics ($T_j = 25^\circ\text{C}$ unless otherwise specified)

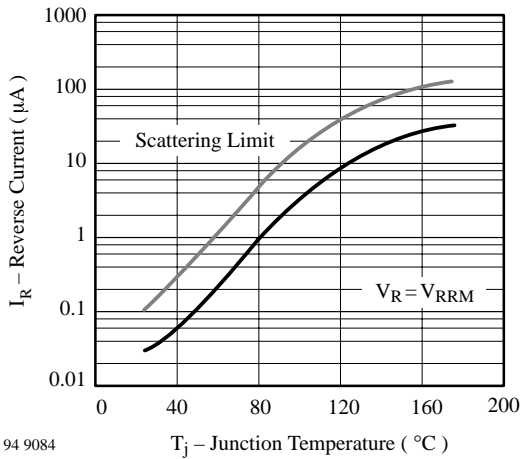

Figure 1. Reverse Current vs. Junction Temperature

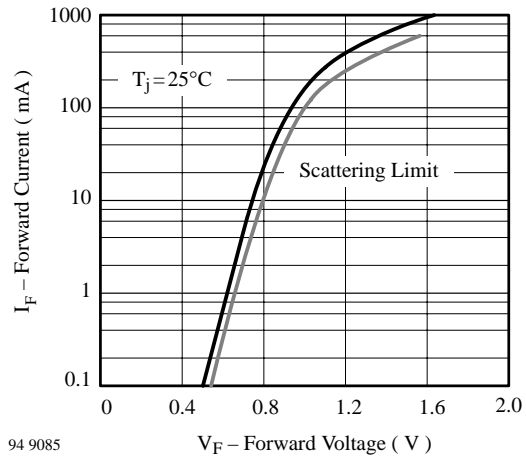

Figure 2. Forward Current vs. Forward Voltage

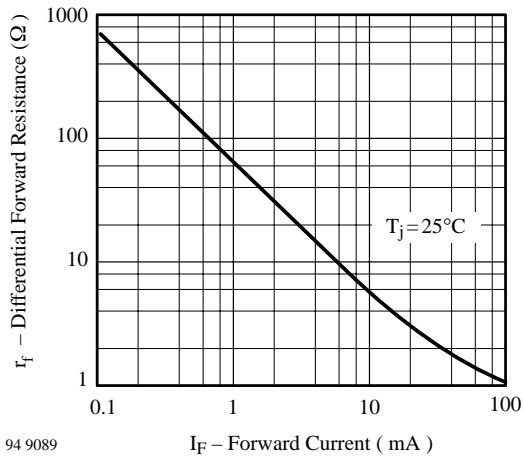

Figure 3. Differential Forward Resistance vs. Forward Current

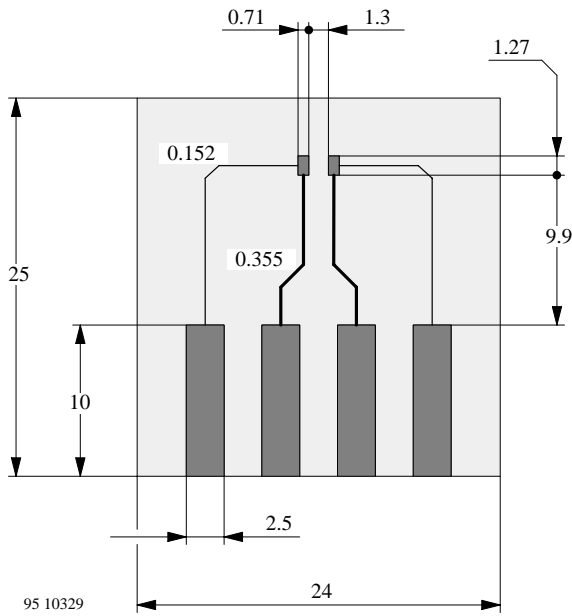

Figure 4. Board for R_{thJA} definition (in mm)

Reflow Soldering

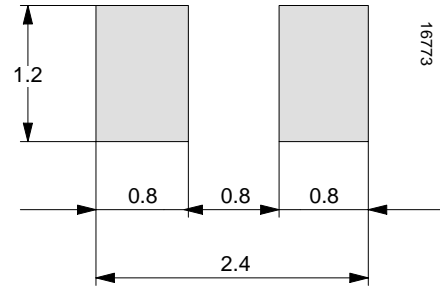

Figure 5.

Wave Soldering

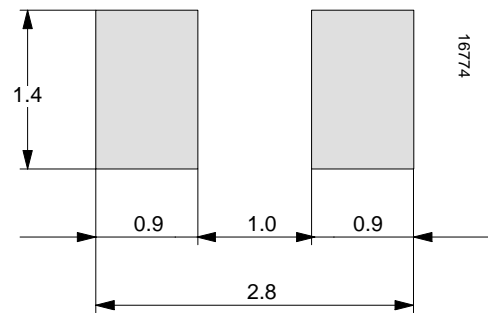
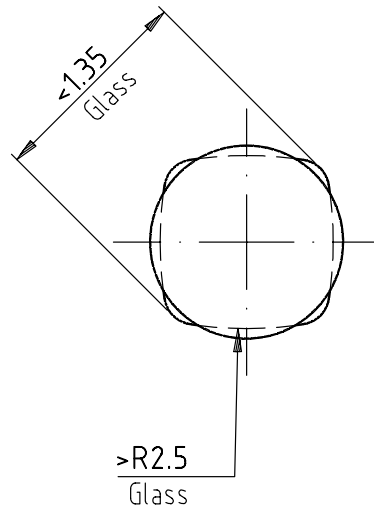
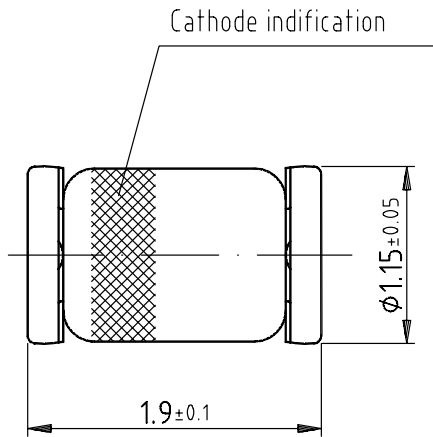

Figure 6.

Dimensions in mm



Glass case
Micro MELF

Drawing-No.: 6.560-5007.01-4
Issue: 5; 06.06.01

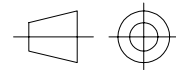

technical drawings
according to DIN
specifications

96 12072



Ozone Depleting Substances Policy Statement

It is the policy of **Vishay Semiconductor GmbH** to

1. Meet all present and future national and international statutory requirements.
2. Regularly and continuously improve the performance of our products, processes, distribution and operating systems with respect to their impact on the health and safety of our employees and the public, as well as their impact on the environment.

It is particular concern to control or eliminate releases of those substances into the atmosphere which are known as ozone depleting substances (ODSs).

The Montreal Protocol (1987) and its London Amendments (1990) intend to severely restrict the use of ODSs and forbid their use within the next ten years. Various national and international initiatives are pressing for an earlier ban on these substances.

Vishay Semiconductor GmbH has been able to use its policy of continuous improvements to eliminate the use of ODSs listed in the following documents.

1. Annex A, B and list of transitional substances of the Montreal Protocol and the London Amendments respectively
2. Class I and II ozone depleting substances in the Clean Air Act Amendments of 1990 by the Environmental Protection Agency (EPA) in the USA
3. Council Decision 88/540/EEC and 91/690/EEC Annex A, B and C (transitional substances) respectively.

Vishay Semiconductor GmbH can certify that our semiconductors are not manufactured with ozone depleting substances and do not contain such substances.

We reserve the right to make changes to improve technical design and may do so without further notice.

Parameters can vary in different applications. All operating parameters must be validated for each customer application by the customer. Should the buyer use Vishay-Semiconductors products for any unintended or unauthorized application, the buyer shall indemnify Vishay-Semiconductors against all claims, costs, damages, and expenses, arising out of, directly or indirectly, any claim of personal damage, injury or death associated with such unintended or unauthorized use.

Vishay Semiconductor GmbH, P.O.B. 3535, D-74025 Heilbronn, Germany
Telephone: 49 (0)7131 67 2831, Fax number: 49 (0)7131 67 2423