

7/8" (22.2 mm) Three Turn Wirewound Upper Grade Precision Potentiometer



FEATURES

- Large range of ohmic values: 5 Ω to 20 kΩ
- Bushing mount or servo mount designs are available
- Gangable up to 3 sections
- Extra taps available upon request

QUICK REFERENCE DATA

Sensor type	ROTATIONAL, multi turn wirewound
Output type	Output by turrets
Market appliance	Professional
Dimensions	7/8" (22.2 mm)

ELECTRICAL SPECIFICATIONS

PARAMETER	STANDARD RANGE	SPECIAL
Total resistance	5 Ω to 20 kΩ	45 kΩ
Tolerance 50 Ω and above	± 3 %	± 1 %
Below 50 Ω	± 5 %	± 3 %
Linearity (independent)	STANDARD	BEST PRACTICAL
Total resistance		
5 Ω to 500 Ω	± 0.25 %	± 0.25 %
500 Ω to 2 kΩ	± 0.25 %	± 0.20 %
2 kΩ and above	± 0.25 %	± 0.125 %
Noise	100 Ω ENR	
Electrical rotation	1080° + 4° - 0°	
Power rating	1.0 W at 70 °C ambient to zero at 125 °C	
Section 1	75 % of the rating of section 1 (0.75 W at 70 °C)	
Additional section		
Insulation resistance	1000 MΩ minimum, 500 V _{DC}	
Dielectric strength	1000 V _{RMS} minimum, 60 Hz	
Absolute minimum resistance	Linearity x total resistance or 0.5 Ω, whichever is greater	
End voltage	Linearity x total applied voltage for total resistance above 20 Ω, 2.0 % of total applied voltage for 20 Ω and below	
Phasing (CCW end points)	Additional sections phased to section 1 within ± 2°	
Taps (extra)	16 available as special, standard tolerance ± 2°	

ORDERING INFORMATION/DESCRIPTION

The model 552 can be ordered from this datasheet with a variety of alternate characteristics, as shown. For most rapid service on your order, please state:

552	B	1	10K	BO1
MODEL	MOUNTING	NUMBER OF SECTIONS	OHMIC VALUE OF SECTION N° 1	PACKAGING
	B: Bushing S: Servo	From 1 up to 3		Box of 1 piece

Other characteristics will be standard as described on this datasheet. If special characteristics are required, such as: special linearity tolerance, special resistance tolerance, extra taps, non-linear functions, etc., please state these on your order and allow additional lead time for delivery.

SAP PART NUMBERING GUIDELINES

552	B	1	103	B01
MODEL	STYLE	NUMBER OF SECTIONS	OHMIC VALUE OF SECTION N° 1	PACKAGING

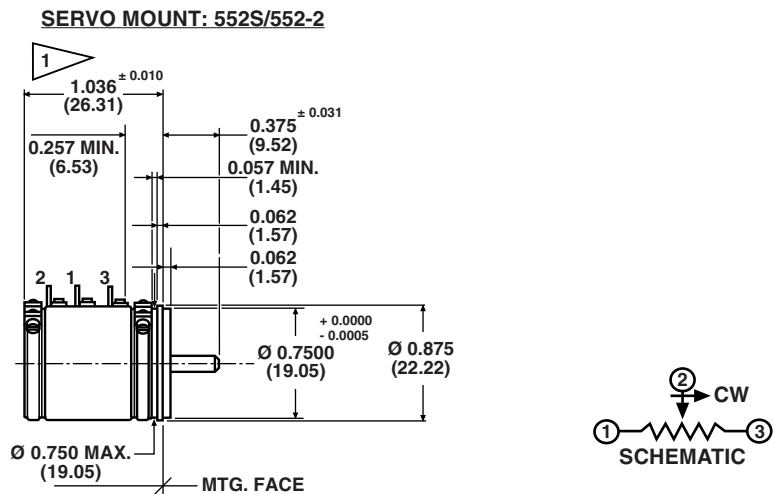
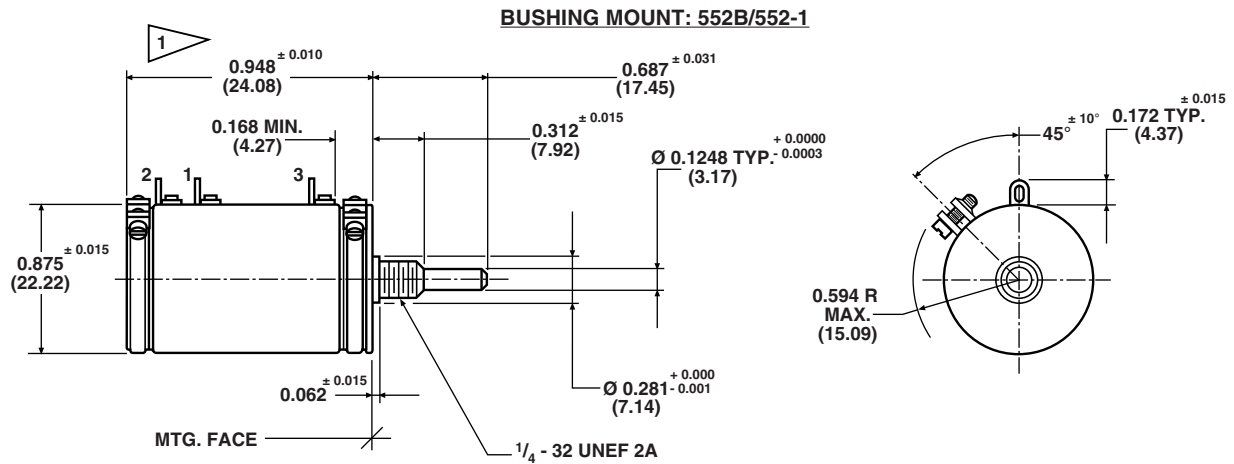
DIMENSIONS in inches (millimeters)

TOLERANCES: UNLESS OTHERWISE NOTED.
DECIMALS ± 0.005 ANGLES ± 2°

1 ADD 0.782 ± 0.002 (19.86) FOR EACH ADDITIONAL SECTION

MECHANICAL SPECIFICATIONS

PARAMETER		
Mechanical rotation	1080° + 10° - 0°	
Bearing type: servo mount	Ball bearing	
Bushing mount	Sleeve bearing	
Torque (maximum)	STARTING	RUNNING
Servo: 1 section	0.4 oz. - in (28.8 g - cm)	0.3 oz. - in (21.6 g - cm)
Bushing: 1 section	0.5 oz. - in (36.0 g - cm)	0.4 oz. - in (28.8 g - cm)
Each additional section	0.3 oz. - in (21.6 g - cm)	0.2 oz. - in (14.4 g - cm)
Mechanical runouts (maximum)	SERVO	BUSHING
Shaft runout (TIR/in)	0.002" (0.05 cm)	0.002" (0.05 cm)
Pilot dia. runout (TIR)	0.002" (0.05 cm)	0.002" (0.05 cm)
Lateral runout (TIR)	0.002" (0.05 cm)	0.005" (0.13 cm)
Shaft end play	0.005" (0.13 cm)	0.005" (0.13 cm)
Shaft radial play	0.002" (0.05 cm)	0.003" (0.08 cm)
Weight (maximum): single section	0.75 oz. (21.7 g)	
Additional section	0.60 oz. (17.0 g)	
Stop strength	100 oz. - in static (7.2 kg - cm)	
Ganging	3 sections maximum, terminal alignment added sections within ± 10° of section 1 terminals	
Moment of inertia	0.30 g - cm ² per section maximum	



MATERIAL SPECIFICATIONS	
Housing	Glass filled phenolic (black)
Lids	Aluminum, anodized
Shaft	Stainless steel, non magnetic, non-passivated
Terminals	Brass, gold plated
Clamp ring	Stainless steel
Bushing mount hardware Lockwasher internal tooth: Panel nut:	Steel, nickel plated Brass, nickel plated

ENVIRONMENTAL SPECIFICATIONS	
Vibration	15 g thru 2000 Hz
Shock	50 g
Salt spray	96 h
Rotational life	600 000 shaft revolutions
Load life	900 h
Operating temperature range	- 65 °C to + 125 °C

MARKING	
Unit identification	Units will be marked with Vishay Spectrol name and model no, resistance and resistance tolerance, linearity, terminal identification, and date code. Example of a marking for a standard part: 552-22102502

POWER RATING CHART

(Ratings for cup N° 1. Additional cups 75 % of values shown)

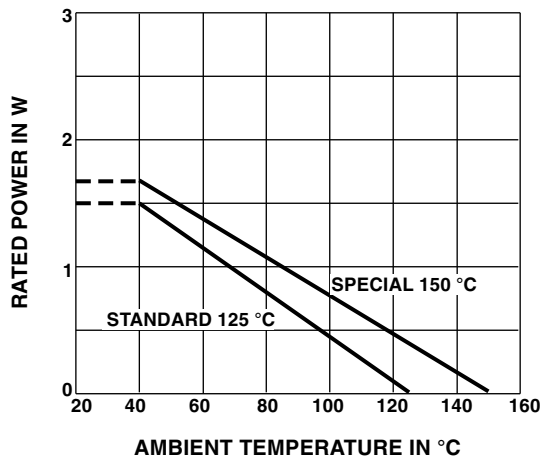

RESISTANCE ELEMENT DATA					
STANDARD RESISTANCE VALUES (Ω)	RESOLUTION (%)	OHMS PER TURN	MAXIMUM CURRENT AT 70 °C AMBIENT (mA)	MAXIMUM VOLTAGE ACROSS COIL (V)	WIRE TEMP. COEF. (ppm/°C)
5	0.265	0.013	447	2.24	800
10	0.182	0.018	316	3.16	800
20	0.155	0.031	224	4.48	800
50	0.150	0.075	141	7.05	180
100	0.125	0.125	100	10.0	20
200	0.116	0.232	70.7	14.1	20
500	0.103	0.517	44.7	22.4	20
1K	0.089	0.886	31.6	31.6	20
2K	0.071	1.411	22.4	44.8	20
5K	0.057	2.828	14.1	70.5	20
10K	0.044	4.381	10.0	100	20
20K	0.036	7.199	7.07	141	20
45K	0.031	14.170	4.71	212	20



Disclaimer

ALL PRODUCT, PRODUCT SPECIFICATIONS AND DATA ARE SUBJECT TO CHANGE WITHOUT NOTICE TO IMPROVE RELIABILITY, FUNCTION OR DESIGN OR OTHERWISE.

Vishay Intertechnology, Inc., its affiliates, agents, and employees, and all persons acting on its or their behalf (collectively, "Vishay"), disclaim any and all liability for any errors, inaccuracies or incompleteness contained in any datasheet or in any other disclosure relating to any product.

Vishay makes no warranty, representation or guarantee regarding the suitability of the products for any particular purpose or the continuing production of any product. To the maximum extent permitted by applicable law, Vishay disclaims (i) any and all liability arising out of the application or use of any product, (ii) any and all liability, including without limitation special, consequential or incidental damages, and (iii) any and all implied warranties, including warranties of fitness for particular purpose, non-infringement and merchantability.

Statements regarding the suitability of products for certain types of applications are based on Vishay's knowledge of typical requirements that are often placed on Vishay products in generic applications. Such statements are not binding statements about the suitability of products for a particular application. It is the customer's responsibility to validate that a particular product with the properties described in the product specification is suitable for use in a particular application. Parameters provided in datasheets and/or specifications may vary in different applications and performance may vary over time. All operating parameters, including typical parameters, must be validated for each customer application by the customer's technical experts. Product specifications do not expand or otherwise modify Vishay's terms and conditions of purchase, including but not limited to the warranty expressed therein.

Except as expressly indicated in writing, Vishay products are not designed for use in medical, life-saving, or life-sustaining applications or for any other application in which the failure of the Vishay product could result in personal injury or death. Customers using or selling Vishay products not expressly indicated for use in such applications do so at their own risk. Please contact authorized Vishay personnel to obtain written terms and conditions regarding products designed for such applications.

No license, express or implied, by estoppel or otherwise, to any intellectual property rights is granted by this document or by any conduct of Vishay. Product names and markings noted herein may be trademarks of their respective owners.

Material Category Policy

Vishay Intertechnology, Inc. hereby certifies that all its products that are identified as RoHS-Compliant fulfill the definitions and restrictions defined under Directive 2011/65/EU of The European Parliament and of the Council of June 8, 2011 on the restriction of the use of certain hazardous substances in electrical and electronic equipment (EEE) - recast, unless otherwise specified as non-compliant.

Please note that some Vishay documentation may still make reference to RoHS Directive 2002/95/EC. We confirm that all the products identified as being compliant to Directive 2002/95/EC conform to Directive 2011/65/EU.

Vishay Intertechnology, Inc. hereby certifies that all its products that are identified as Halogen-Free follow Halogen-Free requirements as per JEDEC JS709A standards. Please note that some Vishay documentation may still make reference to the IEC 61249-2-21 definition. We confirm that all the products identified as being compliant to IEC 61249-2-21 conform to JEDEC JS709A standards.