

Dual PTC Thermistors For Degaussing

a. Dual PTC degaussing.

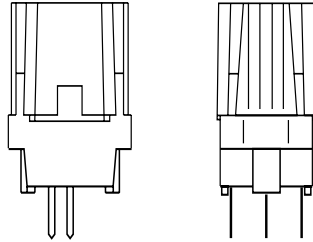

FEATURES

- Residual currents as low as 2 mA
- Long decay time > 110 ms
- Stable performance over a long time (> 40,000 operations)
- Self-extinguishing white plastic case ("UL 94. V.0")
- IEC 60065 certified and UL 1434 approved
- Old part number was 2322 662 96...
- Component in accordance to RoHS 2002/95/EC and WEEE 2002/96/EC

QUICK REFERENCE DATA		
PARAMETER	VALUE	UNIT
Resistance of degaussing PTC (R_s) at 25 °C	3 to 30	Ω
Resistance of heater PTC (R_p) at 25 °C	3000	Ω
Standard tolerance on resistance of heater PTC (R_p) at 25 °C	75	%
Maximum AC voltage (RMS value)	145 to 276	V
Minimum inrush current (peak-to-peak value)	11 to 30	A
Temperature range (at maximum voltage)	0 to 60	°C
Available pitch:		
4e/1e	10.16 to 2.54	mm
4e/2e	10.16 to 5.08	mm
Standard pin length	4.2	mm
Detailed specifications based on	CECC 44000/ IEC 60738	

APPLICATIONS

- Color televisions
- Color monitors

DESCRIPTION

For good picture definition, colour televisions and monitors must be degaussed by a strong alternating magnetic field which gradually and symmetrically decays to a small value of residual current. This can be achieved by connecting a PTC thermistor in the degaussing circuit.

The new generation of flat-screen, high-definition colour televisions and monitors require an excellent picture quality with high colour purity. This can only be achieved by a dual PTC device housing two PTC thermistors in intimate thermal contact, one being used to heat the other and so further reduce the residual current.

DUAL RANGE

ELECTRICAL DATA AND ORDERING INFORMATION												
MINIMUM PEAK-TO-PEAK ⁽²⁾⁽⁵⁾ INRUSH CURRENT (A)	MAXIMUM PEAK-TO-PEAK ⁽²⁾ RESIDUAL CURRENT (mA)			R_{25} Ω		$R_{coil}^{(4)}$ Ω		TYPICAL DECAY PERFORMANCE		TYPE ⁽⁶⁾	CATALOG NUMBER ⁽¹⁾ 2381662	
	after 5 s	after 30 s	after 180 s	R_s	$\pm\%$	MIN.	TYP.	DECAY TIME ⁽³⁾⁽⁴⁾ (ms)	ALPHA MAX. ⁽⁴⁾ (%)		4e/1e pitch	4e/2e pitch
$U_R = 220 \text{ TO } 240 \text{ V}_{RMS} (U_{MAX} = 276 \text{ V}_{RMS})$												
11	50	5	2	30	25	17	25	60	36	-	96209	96309
14	50	5	2	26	25	14	17	40	43	-	96211	96311
16	80	8	4	22	25	14	17	40	44	-	96216	96316
16	80	8	2	22	25	10	17	65	33	LD	96616	96716
20	80	8	2	18	25	10	13	50	38	-	96624	96724
18	80	15	2	18	25	10	17	75	29	LD	96626	96726
25	80	10	4	14	25	10	10	40	45	-	96602	96702
25	80	10	4	14	25	10	10	45	40	LD	96642	96742
21	80	10	5	12	20	10	17	70	36	LT	96606	96706
21	100	20	5	12	20	10	17	80	30	LD/LT	96646	96746
20	100	40	5	9	20	13	20	95	33	LT	96608	96708
20	100	25	10	9	20	13	20	115	26	LD/LT	96648	96748
21	100	40	10	7	20	20	20	110	33	LD/LT	-	96709



ELECTRICAL DATA AND ORDERING INFORMATION												
MINIMUM PEAK-TO-PEAK ⁽²⁾⁽⁵⁾ INRUSH CURRENT (A)	MAXIMUM PEAK-TO-PEAK ⁽²⁾ RESIDUAL CURRENT (mA)			R ₂₅ Ω		R _{coil} ⁽⁴⁾ Ω		TYPICAL DECAY PERFORMANCE		TYPE ⁽⁶⁾	CATALOG NUMBER ⁽¹⁾ 2381662	
	after 5 s	after 30 s	after 180 s	R _s	±%	MIN.	TYP.	DECAY TIME ⁽³⁾⁽⁴⁾ (ms)	ALPHA MAX. ⁽⁴⁾ (%)		4e/1e pitch	4e/2e pitch
U_R = 100 TO 120 V_{RMS} (U_{MAX} = 145 V_{RMS})												
19	200	20	10	7	20	5	7	80	31	LT	96213	96313
27	200	50	14	5	30/15	5	6	85	30	-	96605	96705
30	200	20	10	5	20	4	5	85	31	LD/LT	96645	96745
30	200	20	10	3	30/15	4	6	115	29	LD	96643	96743

Notes

1. Electrical data and catalog numbers. The shading indicates preferred types.
2. All peak-to-peak currents are measured at typical resistance of the coil, at 50 Hz (AC), at 25°C and at 220 Vrms for the 276V types, and 110Vrms for the 145V types.
3. Decay time is the time from the moment of maximum peak current until the half of the maximum peak inrush current.
4. Alpha maximum is the maximum decrease in current expressed in percent between two successive peaks.
5. Inrush currents and decay times at other voltage coil combinations can be derived from Figures 8 to 14, see section 'Introduction, PTC thermistors for degaussing'.
6. LT = low tolerance; LD = long decay.

INRUSH CURRENT

Minimum inrush current as a percentage of mains voltage.

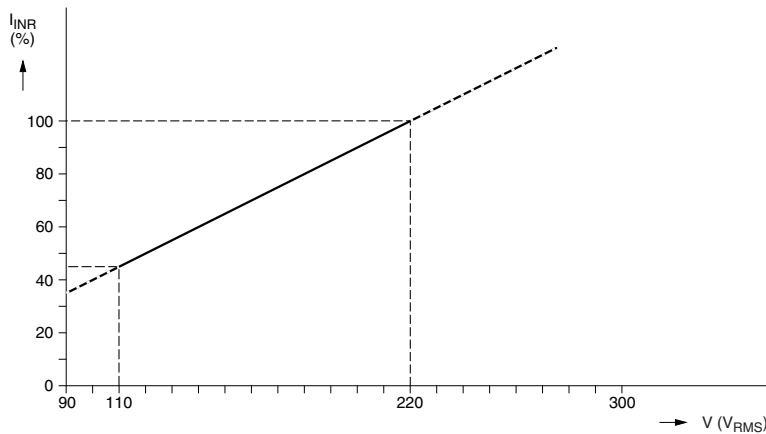

APPLICATION SPECIFIC DATA

The data shown in the above tables is obtained from measurements at reference parameters. If these parameters do not correspond to the application parameters required, refer to Figures 8 to 14 in the "Introduction, PTC thermistors for degaussing", *datasheet*.

COMPONENT OUTLINE, PACKING AND CATALOG NUMBERS		
CODE NUMBER	PACKAGING	OUTLINE
	S.P.Q.	PITCH
2381 662 962..	600	4e / 1e
2381 662 963..	600	4e / 2e
2381 662 966..	600	4e / 1e
2381 662 967..	600	4e / 2e

DIMENSIONS in millimeters

Dual PTC pin configuration 4e/1e pitch.

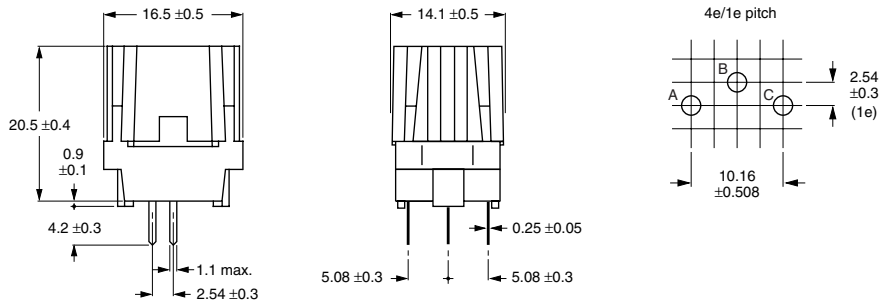

Dual PTC pin configuration 4e/2e pitch.

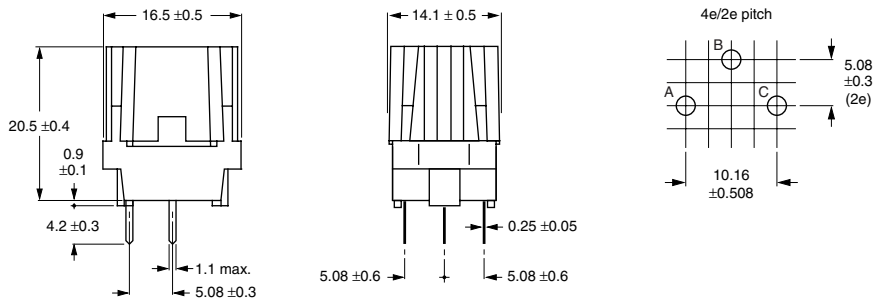

MEASURING CIRCUITS

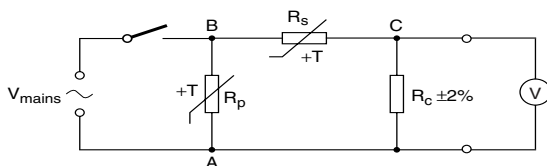

a. Dual cased PTC degaussing.

V = A/D converter or oscilloscope.

R_s = resistance of series PTC or degaussing PTC.

R_p = resistance of parallel PTC or heater PTC.

R_c = replaces the degaussing coil.

V_{mains} = AC power source with high output current capability; frequency = 50 Hz ± 1%; total harmonic distortion < 2%.

For residual current measurement the R_c resistor can be increased to 100 Ω 1%, 30 s after inrush.

PIN CONFIGURATIONS	
CONNECTION	DUAL
MAINS	POINTS A AND B
COIL(S)	POINTS A AND B

DUAL CASED PTC DEGAUSSING

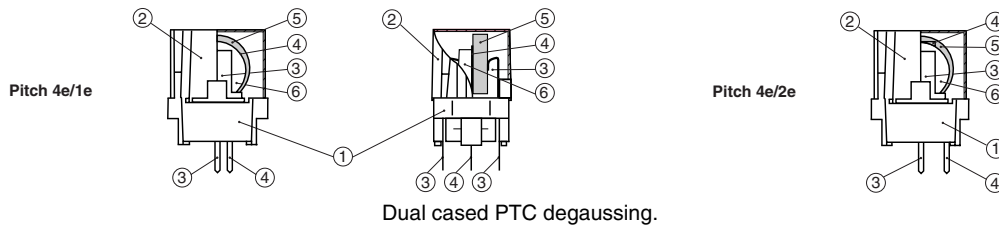

CONSTRUCTION		
NUMBER	DESCRIPTION	MATERIAL AND REMARKS
1	base	glass fibre reinforced polybutyleneterephthalate (PBTP); self-extinguishing according to "UL 94 V-0", UL number E69578(M) or equivalent
2	cap	
3	spring contact (outer)	corrosion resisting steel with nickel/silver flash; pin termination in Sn60Pb40 coated
4	central contact	
5	degaussing PTC thermistor (Rs)	BaTiO ₃ doped
6	heater PTC thermistor (Rp)	

PACKING in millimeters

The thermistors are supplied in cardboard boxes containing 5 trays of 120 items per tray; each box containing 600 units.

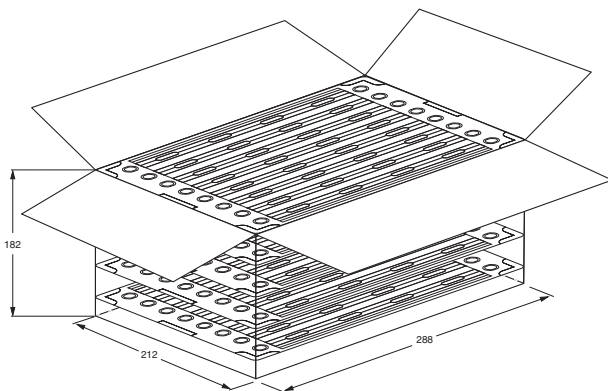

Outer box dimensions.

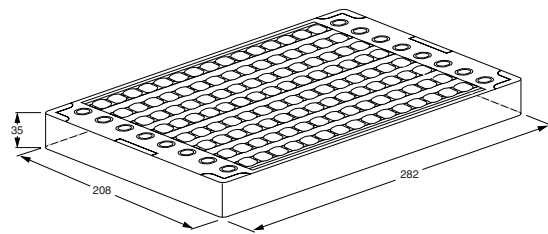

Tray dimensions.