

# NTC Thermistors, High Temperature Sensors



## FEATURES

- Small diameter
- Quick response to temperature change
- High stability over a long life
- Wide temperature range from  $-40$  to  $+200$  °C
- Resistant to corrosive atmospheres and harsh environments

## APPLICATIONS

- High temperature measurement control:
  - Domestic appliances
  - Automotive systems
  - Industrial process control

## DESCRIPTION

These thermistors have a negative temperature coefficient and are mounted in a glass envelope:

2322 633 5.... (SOD80) without leads and suitable for surface mounting

2322 633 8.... (SOD27) with tinned copper-clad iron leads

2322 633 3.... is the bandolier version of 2322 633 8.... series

## MOUNTING

By soldering

QUICK REFERENCE DATA		
PARAMETER	VALUE	
	2322 633 5....	2322 633 8....
Temperature range	$-40$ to $+200$ °C	
Resistance value at 25 °C ( $R_{25}$ )	10 to 100 k $\Omega$	
Tolerance on $R_{25}$ -value	$\pm 5\%$ and $\pm 10\%$	
$B_{25/85}$ -value	3977 K	
Tolerance on $B_{25/85}$ -value	$\pm 1.3\%$	
Deviation in resistance value due to B-tolerance	see Resistance Values at Intermediate Temperatures table for 2322 633 5.... series	see Resistance Values at Intermediate Temperatures table for 2322 633 8.... series
Ratio $R_T/R_{25}$		
Rated dissipation	100 mW	
Dissipation factor	2.5 mW/K	
Response time	0.9 s	
Thermal time constant $\tau$	6 s	
Temperature coefficient	see Resistance Values at Intermediate Temperatures table for 2322 633 5.... series	see Resistance Values at Intermediate Temperatures table for 2322 633 8.... series
Climatic category	40/155/56	40/200/56
Mass	$\approx 0.03$ g	$\approx 0.14$ g

## ELECTRICAL DATA AND ORDERING INFORMATION

$R_{25}$ (k $\Omega$ )	$B_{25/85}$ -VALUE	CATALOG NUMBER 2322 633 .....			
		SOD27 (leaded)		SOD80 (MELF) <sup>(1)</sup>	
		8.... tinned-copper		5....	
		$R_{25} \pm 10\%$	$R_{25} \pm 5\%$	$R_{25} \pm 10\%$	$R_{25} \pm 5\%$
10	3977 K $\pm 1.3\%$	2103	3103	2103	3103
20	3977 K $\pm 1.3\%$	2203	3203	2203	3203
30	3977 K $\pm 1.3\%$	2303	3303	2303	3303
100	3977 K $\pm 1.3\%$	2104	3104	2104	3104
220	3977 K $\pm 1.3\%$	2224	3224	2224	3224

### Note

1. Only available in blister tape.

**DIMENSIONS** in millimeters

Component outline for 2322 633 8.... (SOD27).

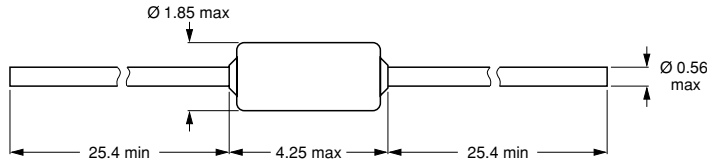

Component outline for 2322 633 5.... (SOD80).

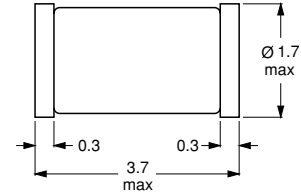

**DERATING**

Derating curve for 2322 633 5.... series.

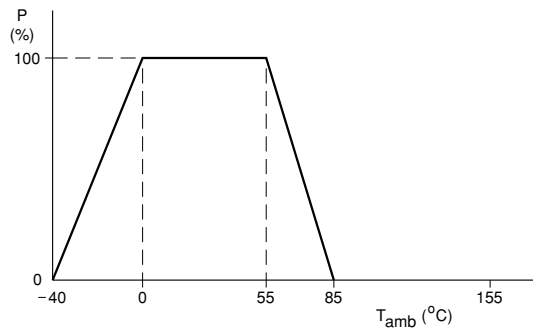

Derating curve for 2322 633 8.... series.

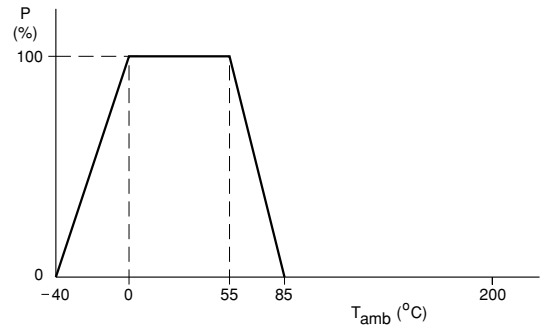

**STABILITY AND R-T CHARACTERISTICS**

Stability of glass encapsulated NTCs after thermal shock test.

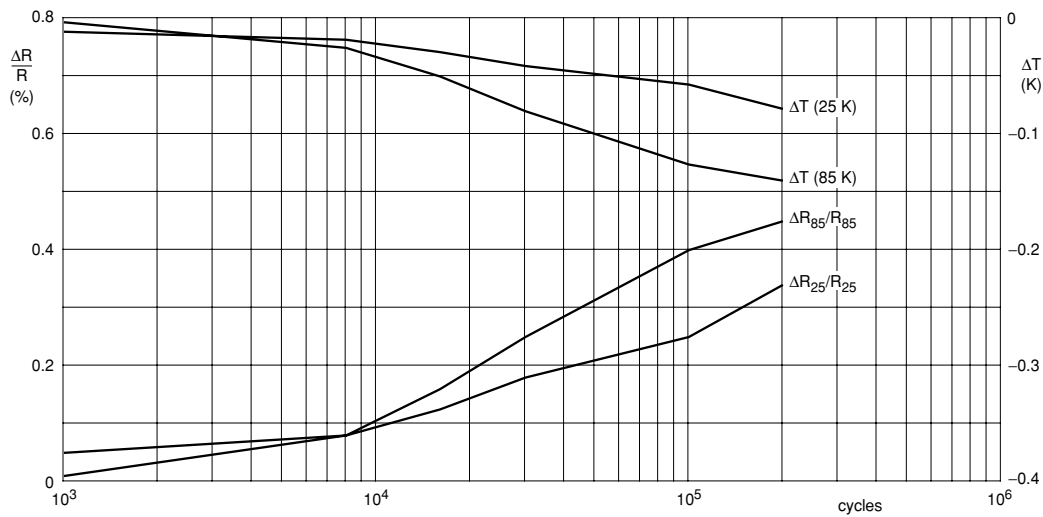



**STABILITY AND R-T CHARACTERISTICS**

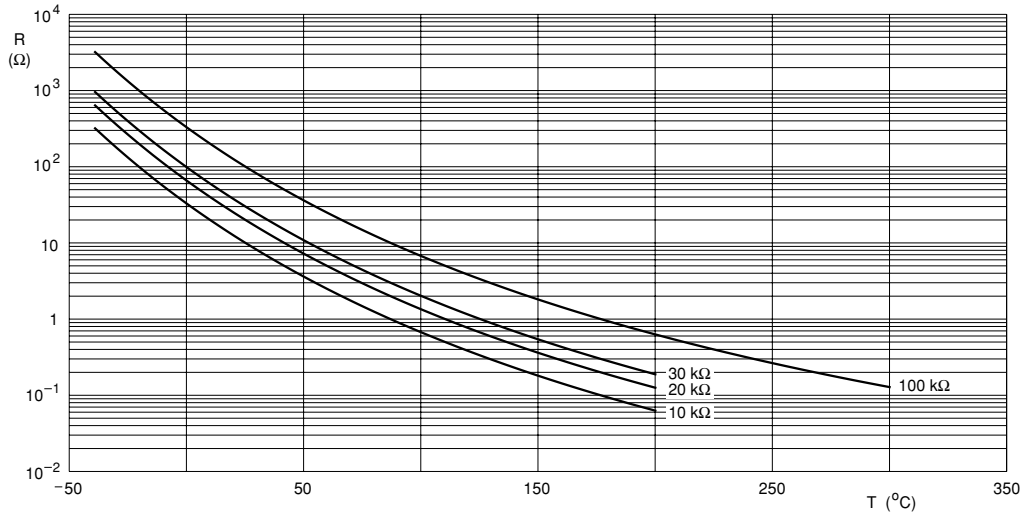

RESISTANCE VALUES AT INTERMEDIATE TEMPERATURES FOR 2322 633 5.... SERIES								
T <sub>oper</sub> (°C)	R <sub>T</sub> /R <sub>25</sub>	ΔR DUE TO B-TOLERANCE (%)	TC (%/K)	R <sub>25</sub>				
				2322 633 ..... (see note 1)				
				5.103	5.203	5.303	5.104	5.224
-40	33.06	4.65	6.59	330.6	661.2	991.8	3306	-
-35	23.90	4.21	6.37	239.0	478.1	717.1	2390	-
-30	17.47	3.79	6.16	174.7	349.4	524.1	1747	-
-25	12.90	3.38	5.96	129.0	258.0	387.0	1290	-
-20	9.621	2.99	5.77	96.21	192.4	288.6	962.1	-
-15	7.242	2.61	5.59	72.42	144.8	217.3	724.2	-
-10	5.501	2.24	5.41	55.01	110.0	165.0	550.1	-
-5	4.214	1.89	5.24	42.14	84.28	126.4	421.4	-
0	3.255	1.55	5.08	32.55	65.09	97.64	325.5	-
5	2.534	1.22	4.93	25.34	50.67	76.01	253.4	-
10	1.987	0.90	4.78	19.87	39.74	59.62	198.7	-
15	1.570	0.59	4.64	15.70	31.40	47.10	157.0	-
20	1.249	0.29	4.51	12.49	24.98	37.46	124.9	-
25	1.000	0.00	4.38	10.00	20.00	30.00	100.0	220000
30	0.8059	0.28	4.25	8.059	16.12	24.18	80.59	179500
35	0.6534	0.55	4.13	6.534	13.07	19.60	65.34	-
40	0.5329	0.82	4.02	5.329	10.66	15.99	53.29	121300
45	0.4371	1.08	3.91	4.371	8.742	13.11	43.71	-
50	0.3604	1.34	3.80	3.604	7.209	10.81	36.04	83630
55	0.2988	1.58	3.70	2.988	5.976	8.963	29.88	-
60	0.2489	1.82	3.60	2.489	4.978	7.467	24.89	58710
65	0.2084	2.06	3.51	2.084	4.168	6.251	20.84	-
70	0.1753	2.29	3.42	1.753	3.505	5.258	17.53	41920
75	0.1481	2.51	3.33	1.481	2.961	4.442	14.81	-
80	0.1256	2.73	3.24	1.256	2.512	3.769	12.56	30410
85	0.1070	2.95	3.16	1.070	2.141	3.211	10.70	-
90	0.09156	3.16	3.08	0.9156	1.831	2.747	9.156	22390
95	0.07862	3.36	3.01	0.7862	1.572	2.359	7.862	-
100	0.06777	3.56	2.93	0.6777	1.355	2.033	6.777	16720
105	0.05863	3.76	2.86	0.5863	1.173	1.759	5.863	-
110	0.05089	3.95	2.79	0.5089	1.018	1.527	5.089	12630
115	0.04433	4.13	2.73	0.4433	0.8865	1.330	4.433	-
120	0.03873	4.32	2.66	0.3873	0.7747	1.162	3.873	9663
125	0.03395	4.50	2.60	0.3395	0.6791	1.019	3.395	-
130	0.02985	4.67	2.54	0.2985	0.5971	0.8956	2.985	7478
135	0.02633	4.84	2.49	0.2633	0.5265	0.7898	2.633	-
140	0.02328	5.01	2.43	0.2328	0.4656	0.6984	2.328	5851
145	0.02065	5.17	2.38	0.2065	0.4129	0.6194	2.065	-
150	0.01836	5.33	2.32	0.1836	0.3671	0.5507	1.836	4625



RESISTANCE VALUES AT INTERMEDIATE TEMPERATURES FOR 2322 633 8.... SERIES								
T <sub>oper</sub> (°C)	R <sub>T</sub> /R <sub>25</sub>	ΔR DUE TO B-TOLERANCE (%)	TC (%/K)	R <sub>25</sub> (kΩ)				
				2322 633 ..... (see note 1)				
				8.103	8.203	8.303	8.104	8.224
-40	33.06	4.65	6.59	330.6	661.2	991.8	3306	-
-35	23.90	4.21	6.37	239.0	478.1	717.1	2390	-
-30	17.47	3.79	6.16	174.7	349.4	524.1	1747	-
-25	12.90	3.38	5.96	129.0	258.0	387.0	1290	-
-20	9.621	2.99	5.77	96.21	192.4	288.6	962.1	-
-15	7.242	2.61	5.59	72.42	144.8	217.3	724.2	-
-10	5.501	2.24	5.41	55.01	110.0	165.0	550.1	-
-5	4.214	1.89	5.24	42.14	84.28	126.4	421.4	-
0	3.255	1.55	5.08	32.55	65.09	97.64	325.5	-
5	2.534	1.22	4.93	25.34	50.67	76.01	253.4	-
10	1.987	0.90	4.78	19.87	39.74	59.62	198.7	-
15	1.570	0.59	4.64	15.70	31.40	47.10	157.0	-
20	1.249	0.29	4.51	12.49	24.98	37.46	124.9	-
25	1.000	0.00	4.38	10.00	20.00	30.00	100.0	220000
30	0.8059	0.28	4.25	8.059	16.12	24.18	80.59	179500
35	0.6534	0.55	4.13	6.534	13.07	19.60	65.34	-
40	0.5329	0.82	4.02	5.329	10.66	15.99	53.29	121300
45	0.4371	1.08	3.91	4.371	8.742	13.11	43.71	-
50	0.3604	1.34	3.80	3.604	7.209	10.81	36.04	83630
55	0.2988	1.58	3.70	2.988	5.976	8.963	29.88	-
60	0.2489	1.82	3.60	2.489	4.978	7.467	24.89	58710
65	0.2084	2.06	3.51	2.084	4.168	6.251	20.84	-
70	0.1753	2.29	3.42	1.753	3.505	5.258	17.53	41920
75	0.1481	2.51	3.33	1.481	2.961	4.442	14.81	-
80	0.1256	2.73	3.24	1.256	2.512	3.769	12.56	30410
85	0.1070	2.95	3.16	1.070	2.141	3.211	10.70	-
90	0.09156	3.16	3.08	0.9156	1.831	2.747	9.156	22390
95	0.07862	3.36	3.01	0.7862	1.572	2.359	7.862	-
100	0.06777	3.56	2.93	0.6777	1.355	2.033	6.777	16720
105	0.05863	3.76	2.86	0.5863	1.173	1.759	5.863	-
110	0.05089	3.95	2.79	0.5089	1.018	1.527	5.089	12630
115	0.04433	4.13	2.73	0.4433	0.8865	1.330	4.433	-
120	0.03873	4.32	2.66	0.3873	0.7747	1.162	3.873	9663
125	0.03395	4.50	2.60	0.3395	0.6791	1.019	3.395	-
130	0.02985	4.67	2.54	0.2985	0.5971	0.8956	2.985	7478
135	0.02633	4.84	2.49	0.2633	0.5265	0.7898	2.633	-
140	0.02328	5.01	2.43	0.2328	0.4656	0.6984	2.328	5851
145	0.02065	5.17	2.38	0.2065	0.4129	0.6194	2.065	-
150	0.01836	5.33	2.32	0.1836	0.3671	0.5507	1.836	4625
155	0.01636	5.49	2.27	0.1636	0.3273	0.4909	1.636	-
160	0.01455	5.65	2.23	0.1455	0.2910	0.4365	1.455	3691
165	0.01303	5.80	2.18	0.1303	0.2606	0.3909	1.303	-
170	0.01169	5.95	2.14	0.1169	0.2339	0.3508	1.169	2973
175	0.01052	6.10	2.09	0.1052	0.2104	0.3156	1.052	-
180	0.00948	6.24	2.05	0.09484	0.1897	0.2845	0.9484	2415
185	0.00857	6.38	2.01	0.08569	0.1714	0.2571	0.8569	-
190	0.00776	6.52	1.97	0.07757	0.1551	0.2327	0.7757	1978
195	0.00704	6.66	1.93	0.07037	0.1407	0.2111	0.7037	-
200	0.00640	6.79	1.89	0.06396	0.1279	0.1919	0.6396	1632

**Note**

1. Replace dot in last 5-digits of catalog number by a number according to the following list and depending on tolerance on required R<sub>25</sub>-value:
  - a) 3 for a tolerance of ±5%.
  - b) 2 for a tolerance of ±10%.

**PACKAGING**

**BLISTER TAPE AND REEL (2322 633 5....)**

Blister tape

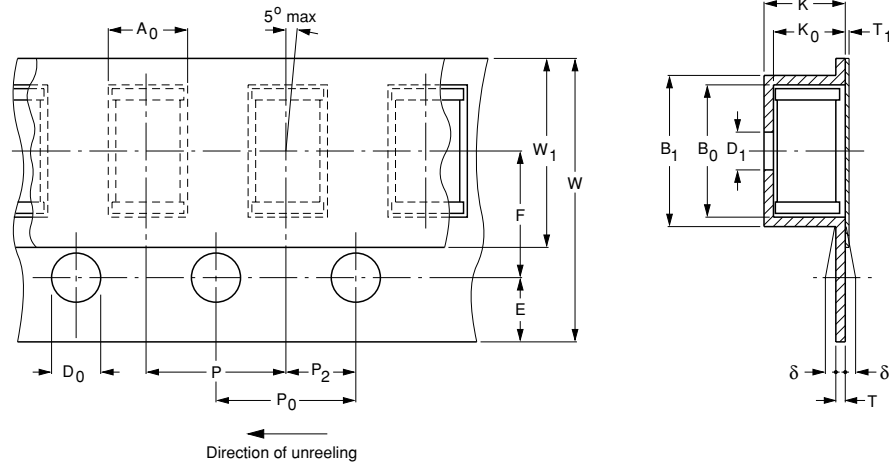

Reel

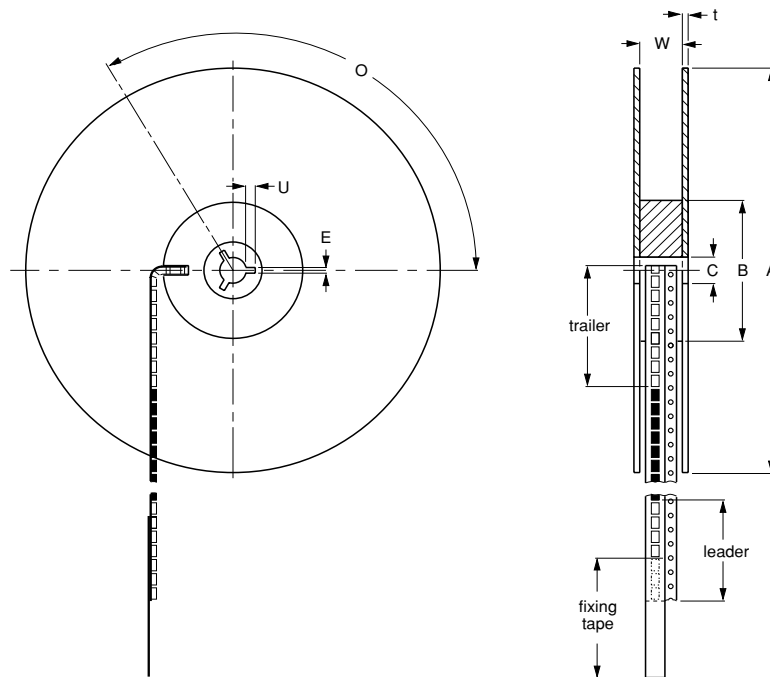

BLISTER TAPE AND REEL DIMENSIONS				
SYMBOL	PARAMETER	NOMINAL DIMENSIONS	TOLERANCE	UNIT
<b>Blister tape</b>				
K	overall thickness	<2.5	-	mm
<b>POCKET</b>				
A <sub>0</sub>	length	2.1	+0.3	mm
B <sub>0</sub>	width	>3.8	-	mm
K <sub>0</sub>	depth	2.1	+0.3	mm

SYMBOL	PARAMETER	NOMINAL DIMENSIONS	TOLERANCE	UNIT
B <sub>1</sub>	outside width	<4.5	–	mm
P	pitch	4.0	±0.1	mm
D <sub>1</sub>	hole diameter	1.0	±0.1	mm
FEED-HOLE				
D <sub>0</sub>	diameter	1.5	±0.1	mm
P <sub>0</sub>	pitch	4.0	±0.1	mm
E	distance	1.75	±0.1	mm
	cumulative pitch error over 10 positions	0	±0.1	mm
CENTRE LINE				
P <sub>2</sub>	length	2.0	±0.05	mm
F	width	3.5	±0.1	mm
FIXING TAPE				
W <sub>1</sub>	width	<5.5	–	mm
T <sub>1</sub>	thickness	<0.1	–	mm
CARRIER TAPE				
W	thickness	8.0	±0.2	mm
δ	bending	<0.3	–	mm
T	thickness	<0.4	–	mm
<b>Reel</b>				
FLANGE				
A	diameter	180	+0	mm
t	thickness	1.5	+0.5	mm
W	space between flanges	9.5	±0.5	mm
HUB				
B	diameter	62.0	±1.5	mm
C	spindle hole	12.75	+0.15/–0	mm
KEY SLIT				
E	width	2.0	±0.5	mm
U	depth	4.0	±0.5	mm
O	location	120	–	°

### THERMISTORS ON BANDOLIER (2322 633 3....)

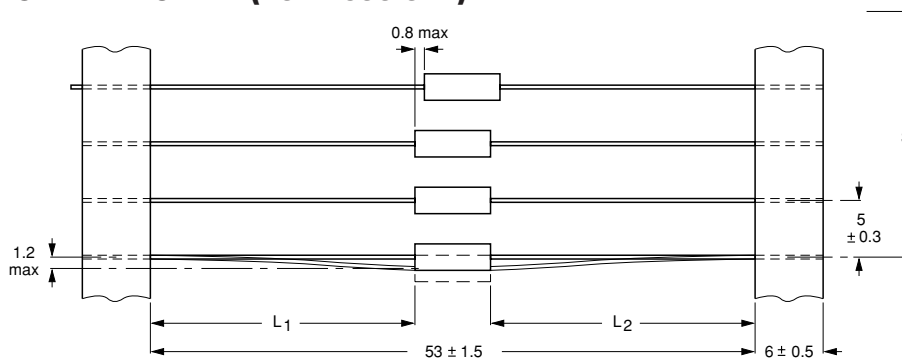

The components are centred so that  $|L_1 - L_2| = 1.2 \text{ mm max.}$   
 The cumulative space (S) measured over 10 spacings =  $50 \pm 2 \text{ mm.}$

#### Note

The bandolier of a 180 mm reel contains at least 2500 devices with no more than 0.5% empty positions. Three consecutive empty places may be found provided this gap is followed by 6 consecutive devices. The carrier tape starts (leader) and ends (trailer) with at least 75 empty positions (equivalent to 300 mm); the covering foil is at least 300 mm. In order to fix the carrier tape a self-adhesive tape of 20 to 50 mm width is applied.