

Aluminum Capacitors

Power Long Life Printed Wiring

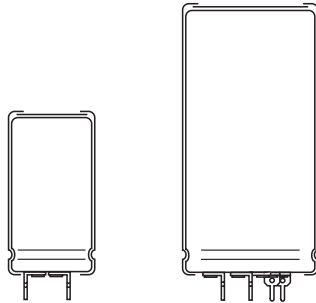
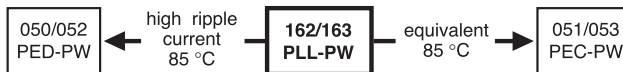

Fig. 1 Component outlines.

FEATURES

- Polarized aluminum electrolytic capacitors, non-solid electrolyte
- Large types, minimized dimensions, cylindrical aluminum case, insulated with a blue sleeve
- Provided with keyed polarity
- Very long useful life: 5000 hours at 105 °C
- Low ESR, high ripple current capability
- Temperature range up to 105 °C
- High resistance to shock and vibration.

RoHS*
COMPLIANT

APPLICATIONS

- Computer, telecommunication and industrial systems
- Smoothing and filtering
- Standard and switched mode power supplies
- Energy storage in pulse systems.

MARKING

The capacitors are marked (where possible) with the following information:

- Rated capacitance (in μF).
- Tolerance on rated capacitance, code letter in accordance with IEC 60062 (M for $\pm 20\%$).
- Rated voltage (in V).
- Date code (YYMM).
- Name of manufacturer.
- Code for factory of origin.
- Polarity of the terminals and '-' sign to indicate the negative terminal, visible from the top and/or side of the capacitor.
- Code number.
- Climatic category in accordance with IEC 60068.

| QUICK REFERENCE DATA | | |
|---|-----------------------------|--------------------------|
| DESCRIPTION | VALUE | |
| | 162 | 163 |
| Nominal case size ($\varnothing D \times L$ in mm) | 25 × 30 to 40 × 100 | |
| Rated capacitance range (E6 series), C_R | 470 to 150000 μF | 68 to 3300 μF |
| Tolerance on C_R | $\pm 20\%$ | |
| Rated voltage range, U_R | 10 to 100 V | 200 to 400 V |
| Category temperature range | -40 to +105 °C | |
| Endurance test at 105 °C | 2000 hours | |
| Useful life at 105 °C | 5000 hours | |
| Useful life at 40 °C, $1.9 \times I_R$ applied | 150000 hours | |
| Shelf life at 0 V, 105 °C | 500 hours | |
| Based on sectional specification | IEC 60384-4/EN130300 | |
| Climatic category IEC 60068 | 40/105/56 | |

| SELECTION CHART FOR C_R , U_R AND RELEVANT NOMINAL CASE SIZES FOR 162 SERIES ($\varnothing D \times L$ in mm) | | | | | | |
|--|-----------|----------|----------|----------|----------|----------|
| C_R (μF) | U_R (V) | | | | | |
| | 10 | 16 | 25 | 40 | 63 | 100 |
| 470 | - | - | - | - | - | 25 × 30 |
| 680 | - | - | - | - | - | 25 × 40 |
| 1000 | - | - | - | - | 25 × 30 | 30 × 40 |
| 1500 | - | - | - | - | 25 × 40 | 35 × 40 |
| 2200 | - | - | - | 25 × 30 | 30 × 40 | 35 × 50 |
| | | | | | | 40 × 40 |
| 3300 | - | - | - | 25 × 40 | 35 × 40 | 40 × 50 |
| 4700 | - | - | 25 × 30 | 30 × 40 | 35 × 50 | 40 × 70 |
| | | | | | 40 × 40 | |
| 6800 | - | 25 × 30 | 25 × 40 | 35 × 40 | 40 × 50 | 40 × 100 |
| 10000 | 25 × 30 | 25 × 40 | 30 × 40 | 35 × 50 | 40 × 70 | - |
| | | | | 40 × 40 | | |
| 15000 | 25 × 40 | 30 × 40 | 35 × 40 | 40 × 50 | 40 × 100 | - |
| 22000 | 30 × 40 | 35 × 40 | 35 × 50 | 40 × 70 | - | - |
| | | | 40 × 40 | | | |
| 33000 | 35 × 40 | 35 × 50 | 40 × 50 | 40 × 100 | - | - |
| | | 40 × 40 | | | | |
| 47000 | 35 × 50 | 40 × 50 | 40 × 70 | - | - | - |
| | 40 × 40 | | | | | |
| 68000 | 40 × 50 | 40 × 70 | 40 × 100 | - | - | - |
| 100000 | 40 × 70 | 40 × 100 | - | - | - | - |
| 150000 | 40 × 100 | - | - | - | - | - |

* Pb containing terminations are not RoHS compliant, exemptions may apply

| C _R (μF) | U _R (V) | | | |
|------------------------|--------------------|----------|----------|----------|
| | 200 | 250 | 385 | 400 |
| 68 | – | – | 25 × 30 | 25 × 30 |
| 100 | – | 25 × 30 | 25 × 40 | 25 × 40 |
| 150 | 25 × 30 | 25 × 40 | 30 × 40 | 30 × 40 |
| 220 | 25 × 40 | 30 × 40 | 35 × 40 | 35 × 40 |
| 330 | 30 × 40 | 35 × 40 | 35 × 50 | 35 × 50 |
| | – | – | 40 × 40 | 40 × 40 |
| 470 | 35 × 40 | 35 × 50 | 40 × 50 | 40 × 50 |
| | – | 40 × 40 | – | – |
| 680 | 35 × 50 | 40 × 50 | 40 × 70 | 40 × 70 |
| | 40 × 50 | – | – | – |
| 1000 | 40 × 50 | 40 × 70 | 40 × 100 | 40 × 100 |
| 1500 | 40 × 70 | 40 × 100 | – | – |
| 2200 | 40 × 100 | – | – | – |

DIMENSIONS in millimeters AND AVAILABLE FORMS

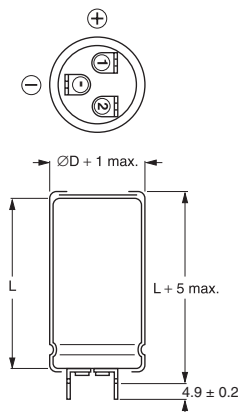

Case ØD = 25 mm.

Fig.2 Printed wiring pin version.

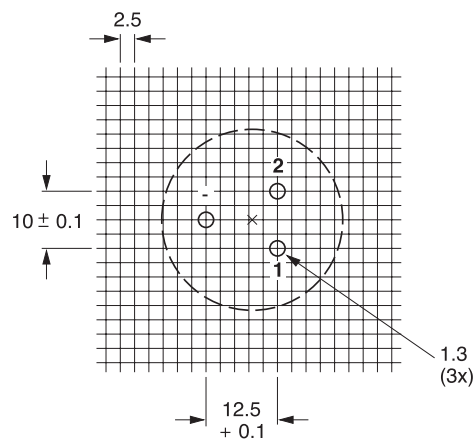

Case ØD = 25 mm.

Fig.3 Mounting hole diagram viewed from component side.

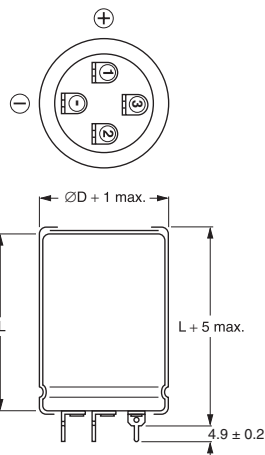

Case ØD = 30 mm.

Fig.4 Printed wiring pin version.

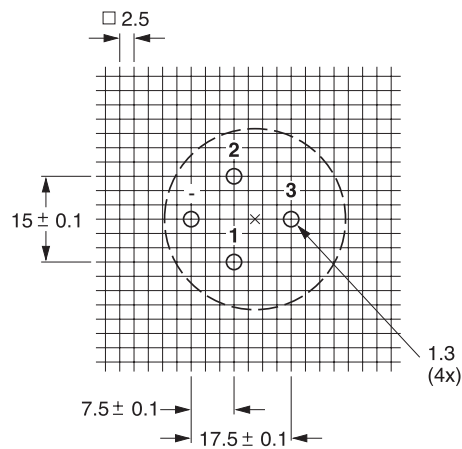

Case ØD = 30 mm.

Fig.5 Mounting hole diagram viewed from component side.



 Case $\varnothing D = 35$ mm.

Fig.6 Printed wiring pin version.

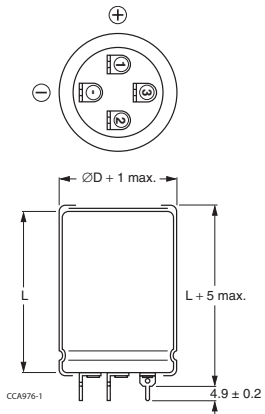

 Case $\varnothing D = 35$ mm.

Fig.7 Mounting hole diagram viewed from component side.

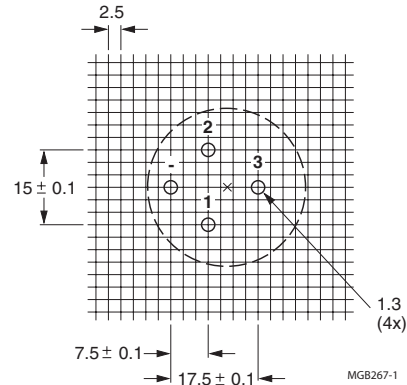

 Case $\varnothing D = 40$ mm.

Fig.8 Printed wiring pin version.

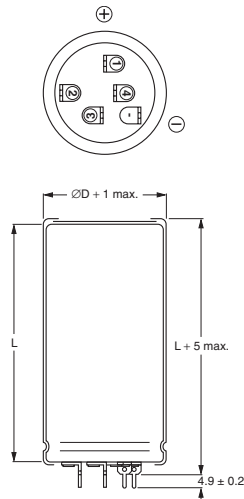

 Case $\varnothing D = 40$ mm.

Fig.9 Mounting hole diagram viewed from component side.

Table 1

| DIMENSIONS in millimeters, MASS AND PACKAGING QUANTITIES PW versions | | | | | |
|--|-----------------------|-----------|-------------|---|---|
| NOMINAL CASE SIZE $\varnothing D \times L$ | $\varnothing D_{MAX}$ | L_{MAX} | MASS (g) | PACKAGING QUANTITIES (units per box) | CARDBOARD BOX DIMENSIONS $L \times W \times H$ |
| 25 × 30 | 26 | 35 | ≈24 | 100 | 290 × 280 × 50 |
| 25 × 40 | 26 | 45 | ≈28 | 100 | 290 × 280 × 60 |
| 30 × 40 | 31 | 45 | ≈38 | 100 | 340 × 330 × 60 |
| 35 × 40 | 36 | 45 | ≈51 | 50 | 390 × 198 × 60 |
| 35 × 50 | 36 | 55 | ≈66 | 50 | 390 × 198 × 70 |
| 40 × 40 | 41 | 45 | ≈78 | 50 | 440 × 223 × 60 |
| 40 × 50 | 41 | 55 | ≈82 | 50 | 440 × 223 × 70 |
| 40 × 70 | 41 | 75 | ≈110 | 25 | 230 × 230 × 90 |
| 40 × 100 | 41 | 105 | ≈176 | 25 | 230 × 230 × 120 |

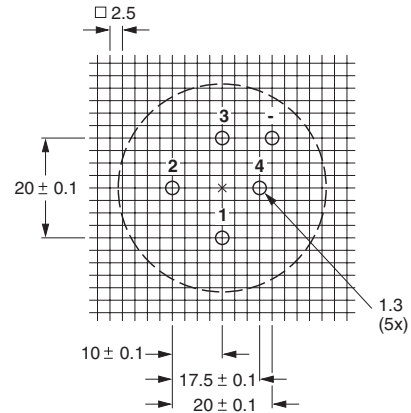
MOUNTING

When a number of capacitors are connected in a bank, they must not be closer together than 15 mm, when no derating of ripple current and/or temperature is applied.

Pin numbers 2, 3 and 4 (if present) must be free from the electrical circuit.

| ELECTRICAL DATA | |
|-----------------|--|
| SYMBOL | DESCRIPTION |
| C _R | rated capacitance at 100 Hz |
| I _R | rated RMS ripple current at 100 Hz and 105 °C |
| I _{L1} | max. leakage current after 1 minute at U _R |
| I _{L5} | max. leakage current after 5 minutes at U _R |
| ESR | max. equivalent series resistance at 100 Hz |
| Z | max. impedance at 10 kHz |

ORDERING EXAMPLE*

Electrolytic capacitor 162 series

10000 µF/25 V; ± 20 %

Nominal case size: Ø30 × 40 mm

Catalog number: 2222 162 56103.

* Note: To ensure delivery of lead (Pb)-free parts during the transition period, please contact your Vishay sales agent.

Note

1. Unless otherwise specified, all electrical values in Tables 2 and 3 apply at T_{amb} = 20 °C, P = 86 to 106 kPa, RH = 45 to 75%.

Table 2

| ELECTRICAL DATA AND ORDERING INFORMATION FOR 162 SERIES | | | | | | | | |
|---|----------------------------------|--|---|----------------------------------|----------------------------------|-----------------------|---------------------|----------------------------------|
| U _R (V) | C _R 100 Hz (µF) | NOMINAL CASE SIZE ØD × L (mm) | I _R 100 Hz 105 °C (A) | I _{L1} 1 min (mA) | I _{L5} 5 min (mA) | ESR 100 Hz (mΩ) | Z 10 kHz (mΩ) | CATALOG NUMBER 2222 |
| 10 | 10000 | 25 × 30 | 3.17 | 0.60 | 0.20 | 48 | 37 | 162 54103 |
| | 15000 | 25 × 40 | 4.21 | 0.90 | 0.30 | 34 | 27 | 162 54153 |
| | 22000 | 30 × 40 | 5.05 | 1.32 | 0.44 | 29 | 23 | 162 54223 |
| | 33000 | 35 × 40 | 5.63 | 1.98 | 0.66 | 27 | 22 | 162 54333 |
| | 47000 | 35 × 50 | 6.19 | 2.82 | 0.94 | 26 | 21 | 162 54473 |
| | 47000 | 40 × 40 | 6.19 | 2.82 | 0.94 | 26 | 21 | 162 44473 |
| | 68000 | 40 × 50 | 7.64 | 4.08 | 1.36 | 21 | 18 | 162 54683 |
| | 100000 | 40 × 70 | 10.0 | 6.00 | 2.00 | 16 | 15 | 162 54104 |
| 150000 | 40 × 100 | 12.9 | 9.00 | 3.00 | 13 | 12 | 162 54154 | |
| 16 | 6800 | 25 × 30 | 3.11 | 0.65 | 0.22 | 50 | 37 | 162 55682 |
| | 10000 | 25 × 40 | 4.09 | 0.96 | 0.32 | 36 | 27 | 162 55103 |
| | 15000 | 30 × 40 | 4.97 | 1.44 | 0.48 | 30 | 23 | 162 55153 |
| | 22000 | 35 × 40 | 5.53 | 2.12 | 0.71 | 29 | 22 | 162 55223 |
| | 33000 | 35 × 50 | 6.08 | 3.17 | 1.06 | 28 | 21 | 162 55333 |
| | 33000 | 40 × 40 | 6.08 | 3.17 | 1.06 | 28 | 21 | 162 45333 |
| | 47000 | 40 × 50 | 7.46 | 4.52 | 1.51 | 22 | 18 | 162 55473 |
| | 68000 | 40 × 70 | 9.70 | 6.53 | 2.18 | 17 | 15 | 162 55683 |
| 100000 | 40 × 100 | 12.90 | 9.60 | 3.20 | 13 | 12 | 162 55104 | |
| 25 | 4700 | 25 × 30 | 2.94 | 0.71 | 0.24 | 56 | 37 | 162 56472 |
| | 6800 | 25 × 40 | 3.93 | 1.02 | 0.34 | 39 | 27 | 162 56682 |
| | 10000 | 30 × 40 | 4.81 | 1.50 | 0.50 | 32 | 23 | 162 56103 |
| | 15000 | 35 × 40 | 5.43 | 2.25 | 0.75 | 30 | 22 | 162 56153 |
| | 22000 | 35 × 50 | 5.98 | 3.30 | 1.10 | 29 | 21 | 162 56223 |
| | 22000 | 40 × 40 | 5.98 | 3.30 | 1.10 | 29 | 21 | 162 46223 |
| | 33000 | 40 × 50 | 7.30 | 4.95 | 1.65 | 23 | 18 | 162 56333 |
| | 47000 | 40 × 70 | 9.43 | 7.05 | 2.35 | 18 | 15 | 162 56473 |
| 68000 | 40 × 100 | 12.44 | 10.20 | 3.40 | 14 | 12 | 162 56683 | |
| 40 | 2200 | 25 × 30 | 2.36 | 0.53 | 0.18 | 87 | 54 | 162 57222 |
| | 3300 | 25 × 40 | 3.17 | 0.79 | 0.27 | 60 | 38 | 162 57332 |
| | 4700 | 30 × 40 | 3.93 | 1.13 | 0.38 | 48 | 33 | 162 57472 |
| | 6800 | 35 × 40 | 4.59 | 1.63 | 0.55 | 42 | 31 | 162 57682 |
| | 10000 | 35 × 50 | 5.03 | 2.40 | 0.80 | 41 | 29 | 162 57103 |
| | 10000 | 40 × 40 | 5.03 | 2.40 | 0.80 | 41 | 29 | 162 47103 |
| | 15000 | 40 × 50 | 6.09 | 3.60 | 1.20 | 33 | 24 | 162 57153 |
| | 22000 | 40 × 70 | 8.34 | 5.28 | 1.76 | 23 | 18 | 162 57223 |
| 33000 | 40 × 100 | 10.97 | 7.92 | 2.64 | 18 | 15 | 162 57333 | |
| 63 | 1000 | 25 × 30 | 1.55 | 0.38 | 0.13 | 202 | 155 | 162 58102 |
| | 1500 | 25 × 40 | 2.10 | 0.57 | 0.19 | 137 | 109 | 162 58152 |
| | 2200 | 30 × 40 | 2.72 | 0.83 | 0.28 | 100 | 79 | 162 58222 |
| | 3300 | 35 × 40 | 3.44 | 1.25 | 0.42 | 75 | 61 | 162 58332 |
| | 4700 | 35 × 50 | 4.09 | 1.78 | 0.60 | 62 | 53 | 162 58472 |
| | 4700 | 40 × 40 | 4.09 | 1.78 | 0.60 | 62 | 53 | 162 48472 |
| | 6800 | 40 × 50 | 5.10 | 2.57 | 0.86 | 47 | 40 | 162 58682 |
| | 10000 | 40 × 70 | 6.86 | 3.78 | 1.26 | 34 | 29 | 162 58103 |
| 15000 | 40 × 100 | 9.31 | 5.67 | 1.89 | 25 | 21 | 162 58153 | |
| 100 | 470 | 25 × 30 | 1.42 | 0.28 | 0.10 | 240 | 155 | 162 59471 |
| | 680 | 25 × 40 | 1.90 | 0.41 | 0.14 | 167 | 109 | 162 59681 |
| | 1000 | 30 × 40 | 2.48 | 0.60 | 0.20 | 120 | 79 | 162 59102 |
| | 1500 | 35 × 40 | 3.17 | 0.90 | 0.30 | 88 | 61 | 162 59152 |
| | 2200 | 35 × 50 | 3.79 | 1.32 | 0.44 | 72 | 53 | 162 59222 |
| | 2200 | 40 × 40 | 3.79 | 1.32 | 0.44 | 72 | 53 | 162 49222 |
| | 3300 | 40 × 50 | 4.81 | 1.98 | 0.66 | 53 | 40 | 162 59332 |
| | 4700 | 40 × 70 | 6.49 | 2.82 | 0.94 | 38 | 29 | 162 59472 |
| 6800 | 40 × 100 | 8.80 | 4.08 | 1.36 | 28 | 21 | 162 59682 | |



Table 3

| ELECTRICAL DATA AND ORDERING INFORMATION FOR 163 SERIES | | | | | | | | |
|---|----------------------------------|--|---|----------------------------------|----------------------------------|-----------------------|---------------------|----------------------------------|
| U _R (V) | C _R 100 Hz (MF) | NOMINAL CASE SIZE ØD × L (mm) | I _R 100 Hz 105 °C (A) | I _{L1} 1 min (mA) | I _{L5} 5 min (mA) | ESR 100 Hz (mΩ) | Z 10 kHz (mΩ) | CATALOG NUMBER 2222 |
| 200 | 150 | 25 × 30 | 0.72 | 0.18 | 0.06 | 950 | 710 | 163 52151 |
| | 220 | 25 × 40 | 0.96 | 0.26 | 0.09 | 650 | 485 | 163 52221 |
| | 330 | 30 × 40 | 1.29 | 0.40 | 0.14 | 442 | 330 | 163 52331 |
| | 470 | 35 × 40 | 1.66 | 0.57 | 0.19 | 321 | 240 | 163 52471 |
| | 680 | 35 × 50 | 2.09 | 0.82 | 0.28 | 237 | 185 | 163 52681 |
| | 680 | 40 × 40 | 2.09 | 0.82 | 0.28 | 237 | 185 | 163 42681 |
| | 1000 | 40 × 50 | 2.71 | 1.20 | 0.40 | 167 | 133 | 163 52102 |
| | 1500 | 40 × 70 | 3.75 | 1.80 | 0.60 | 114 | 90 | 163 52152 |
| 250 | 2200 | 40 × 100 | 5.24 | 2.64 | 0.88 | 79 | 62 | 163 52222 |
| | 100 | 25 × 30 | 0.67 | 0.15 | 0.05 | 1060 | 710 | 163 53101 |
| | 150 | 25 × 40 | 0.92 | 0.22 | 0.08 | 710 | 485 | 163 53151 |
| | 220 | 30 × 40 | 1.28 | 0.33 | 0.11 | 492 | 330 | 163 53221 |
| | 330 | 35 × 40 | 1.65 | 0.49 | 0.17 | 325 | 240 | 163 53331 |
| | 470 | 35 × 50 | 2.01 | 0.70 | 0.24 | 256 | 185 | 163 53471 |
| | 470 | 40 × 40 | 2.01 | 0.70 | 0.24 | 256 | 185 | 163 43471 |
| | 680 | 40 × 50 | 2.59 | 1.02 | 0.34 | 182 | 133 | 163 53681 |
| 385 | 1000 | 40 × 70 | 3.58 | 1.50 | 0.50 | 125 | 90 | 163 53102 |
| | 1500 | 40 × 100 | 5.05 | 2.25 | 0.75 | 85 | 62 | 163 53152 |
| | 68 | 25 × 30 | 0.61 | 0.16 | 0.06 | 1650 | 1260 | 163 58689 |
| | 100 | 25 × 40 | 0.82 | 0.23 | 0.08 | 1120 | 855 | 163 58101 |
| | 150 | 30 × 40 | 1.10 | 0.35 | 0.12 | 755 | 580 | 163 58151 |
| | 220 | 35 × 40 | 1.44 | 0.51 | 0.17 | 525 | 405 | 163 58221 |
| | 330 | 35 × 50 | 1.84 | 0.77 | 0.26 | 360 | 280 | 163 58331 |
| | 330 | 40 × 40 | 1.84 | 0.77 | 0.26 | 360 | 280 | 163 48331 |
| 400 | 470 | 40 × 50 | 2.37 | 1.09 | 0.36 | 260 | 205 | 163 58471 |
| | 680 | 40 × 70 | 3.24 | 1.58 | 0.53 | 180 | 140 | 163 58681 |
| | 1000 | 40 × 100 | 4.54 | 2.31 | 0.78 | 125 | 100 | 163 58102 |
| | 68 | 25 × 30 | 0.39 | 0.16 | 0.06 | 3200 | 2660 | 163 56689 |
| | 100 | 25 × 40 | 0.53 | 0.24 | 0.08 | 2180 | 1810 | 163 56101 |
| | 150 | 30 × 40 | 0.72 | 0.36 | 0.12 | 1460 | 1210 | 163 56151 |
| | 220 | 35 × 40 | 0.94 | 0.52 | 0.17 | 1010 | 830 | 163 56221 |
| | 330 | 35 × 50 | 1.24 | 0.79 | 0.26 | 680 | 570 | 163 56331 |
| 400 | 330 | 40 × 40 | 1.24 | 0.79 | 0.26 | 680 | 570 | 163 46331 |
| | 470 | 40 × 50 | 1.59 | 1.12 | 0.37 | 485 | 407 | 163 56471 |
| | 680 | 40 × 70 | 2.18 | 1.63 | 0.54 | 336 | 282 | 163 56681 |
| | 1000 | 40 × 100 | 3.07 | 2.40 | 0.80 | 230 | 193 | 163 56102 |

| ADDITIONAL ELECTRICAL DATA | | |
|------------------------------------|-----------------------------------|--|
| PARAMETER | CONDITIONS | VALUE |
| Voltage | | |
| Surge voltage | ≤ 200 V versions | U _s = 1.15 × U _R |
| | ≥ 385 V versions | U _s = 1.1 × U _R |
| Reverse voltage | | U _{rev} ≤ 1 V |
| Current | | |
| Leakage current | after 1 minute at U _R | I _{L1} ≤ 0.006 C _R × U _R + 4 μA |
| | after 5 minutes at U _R | I _{L5} ≤ 0.002 C _R × U _R + 4 μA |
| Inductance | | |
| Equivalent series inductance (ESL) | case ØD = 25 mm | max. 25 nH |
| | case ØD = 30 and 35 mm | max. 30 nH |
| | case ØD = 40 mm | max. 35 nH |



RIPPLE CURRENT AND USEFUL LIFE

MGA454

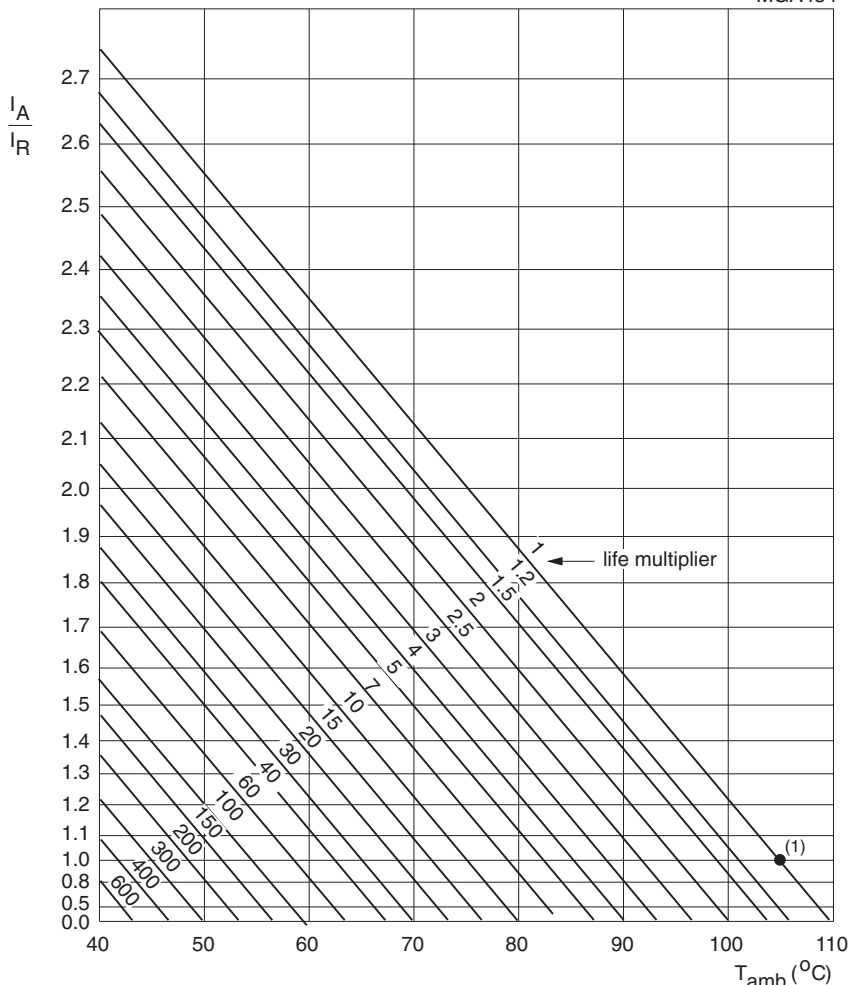

I_A = actual ripple current at 100 Hz.
 I_R = rated ripple current at 100 Hz. and 105 °C.
 (1) Useful life at 105 °C and I_R applied: 5000 hours.

Fig.10 Multiplier of useful life as a function of ambient temperature and ripple current load.

Table 4

| MULTIPLIER OF RIPPLE CURRENT (I_R) AS A FUNCTION OF FREQUENCY | | | |
|---|-------------------------------------|--------------------------------------|---------------------------------------|
| FREQUENCY (Hz) | I_R MULTIPLIER | | |
| | $U_R = 10 \text{ to } 25 \text{ V}$ | $U_R = 40 \text{ to } 100 \text{ V}$ | $U_R = 200 \text{ to } 400 \text{ V}$ |
| 50 | 0.93 | 0.91 | 0.86 |
| 100 | 1.00 | 1.00 | 1.00 |
| 200 | 1.04 | 1.05 | 1.13 |
| 400 | 1.07 | 1.09 | 1.21 |
| 1000 | 1.11 | 1.13 | 1.29 |
| 2000 | 1.13 | 1.15 | 1.32 |
| 4000 | 1.15 | 1.18 | 1.35 |
| ≥ 10000 | 1.18 | 1.22 | 1.40 |



Table 5

| TEST PROCEDURES AND REQUIREMENT | | | |
|--|--|--|---|
| TEST | | PROCEDURE (quick reference) | REQUIREMENTS |
| NAME OF TEST | REFERENCE | | |
| Endurance | IEC 60384-4/ EN130300 subclause 4.13 | $T_{amb} = 105\text{ °C}$; U_R applied; 2000 hours | $U_R \leq 100\text{ V}$; $\Delta C/C$: $\pm 15\%$ $U_R > 100\text{ V}$; $\Delta C/C$: $\pm 10\%$ $ESR \leq 1.3 \times \text{spec. limit}$ $Z \leq 2 \times \text{spec. limit}$ $I_{L5} \leq \text{spec. limit}$ |
| Useful life | CECC 30301 subclause 1.8.1 | $T_{amb} = 105\text{ °C}$; U_R and I_R applied; 5000 hours | $U_R \leq 100\text{ V}$; $\Delta C/C$: $\pm 45\%$ $U_R > 100\text{ V}$; $\Delta C/C$: $\pm 30\%$ $ESR \leq 3 \times \text{spec. limit}$ $Z \leq 3 \times \text{spec. limit}$ $I_{L5} \leq \text{spec. limit}$ no short or open circuit, no visible damage total failure percentage: $U_R \leq 100\text{ V}$: $\leq 1\%$; $U_R > 100\text{ V}$: $\leq 3\%$ |
| Shelf life (storage at high temperature) | IEC 60384-4/ EN130300 subclause 4.17 | $T_{amb} = 105\text{ °C}$; no voltage applied; 500 hours after test: U_R to be applied for 30 minutes, 24 to 48 hours before measurement | $\Delta C/C$: $\pm 10\%$ $ESR \leq 1.2 \times \text{spec. limit}$ $I_{L5} \leq 2 \times \text{spec. limit}$ |



Notice

Specifications of the products displayed herein are subject to change without notice. Vishay Intertechnology, Inc., or anyone on its behalf, assumes no responsibility or liability for any errors or inaccuracies.

Information contained herein is intended to provide a product description only. No license, express or implied, by estoppel or otherwise, to any intellectual property rights is granted by this document. Except as provided in Vishay's terms and conditions of sale for such products, Vishay assumes no liability whatsoever, and disclaims any express or implied warranty, relating to sale and/or use of Vishay products including liability or warranties relating to fitness for a particular purpose, merchantability, or infringement of any patent, copyright, or other intellectual property right.

The products shown herein are not designed for use in medical, life-saving, or life-sustaining applications. Customers using or selling these products for use in such applications do so at their own risk and agree to fully indemnify Vishay for any damages resulting from such improper use or sale.