

Aluminum Capacitors

Axial High Temperature, High Ripple Current

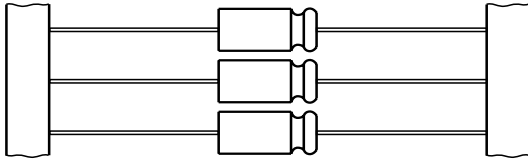
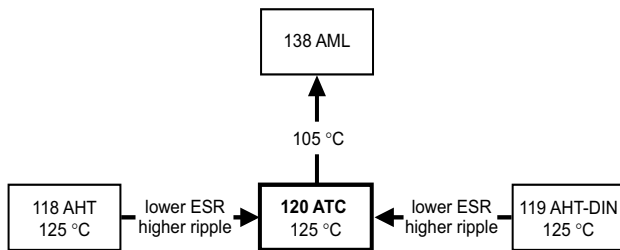

Fig.1 Component outlines

FEATURES

- Polarized aluminum electrolytic capacitors, non-solid electrolyte
- Axial leads, cylindrical aluminum case, insulated with a blue sleeve
- Mounting ring version not available in insulated form
- Taped versions up to case \varnothing 15 x 30 mm available for automatic insertion
- Charge and discharge proof
- Extra long useful life: up to 8000 hours at 125 °C, high reliability
- Lowest ESR levels providing very high ripple current capability
- Extended temperature range: usable up to 150 °C
- Miniaturized, high CV-product per unit volume
- Lead diameter \varnothing d = 1.0 mm, available on request
- Lead (Pb)-free versions are RoHS compliant

RoHS*
COMPLIANT

APPLICATIONS

- Automotive, industrial and telecommunication
- Smoothing, filtering, buffering
- Low mounting height applications, vibration and shock resistant
- SMPS and standard power supplies

MARKING

The capacitors are marked (where possible) with the following information:

- Rated capacitance (in μ F)
- Tolerance on rated capacitance, code letter in accordance with IEC 60062 (M for \pm 20 %)
- Rated voltage (in V)
- Upper category temperature (125 °C)
- Date code in accordance with IEC 60062
- Code for factory of origin
- Name of manufacturer
- Band to indicate the negative terminal
- '+' sign to identify the positive terminal
- Series number (120)

QUICK REFERENCE DATA	
DESCRIPTION	VALUE
Nominal case sizes (\varnothing D x L in mm)	10 x 30 to 21 x 38
Rated capacitance range, C_R	47 to 6800 μ F
Tolerance on C_R	\pm 20 %
Rated voltage range, U_R	16 to 100 V
Category temperature range	- 40 to + 125 °C
Endurance test at 150 °C	1000 hours
Endurance test at 125 °C	4000 hours
Useful life at 125 °C	8000 hours
Useful life at 85 °C, $1.4 \times I_R$ applied	40000 hours
Shelf life at 0 V, 125 °C	1000 hours (100 V: 500 hours)
Shelf life at 0 V, 150 °C	\leq 63 V: 500 hours
Based on sectional specification	IEC 60384-4/EN130300
Climatic category IEC 60068	40/125/56

* Pb containing terminations are not RoHS compliant, exemptions may apply

SELECTION CHART FOR C_R , U_R AND RELEVANT NOMINAL CASE SIZE ($\varnothing D \times L$ in mm)					
C_R (μF)	U_R (V)				
	16	25	40	63	100
47	-	-	-	-	10 × 30
68	-	-	-	-	12.5 × 30
100	-	-	-	10 × 30	12.5 × 30
150	-	-	-	12.5 × 30	15 × 30
220	-	-	10 × 30	12.5 × 30	18 × 30
330	-	-	12.5 × 30	15 × 30	18 × 38
470	-	10 × 30	12.5 × 30	18 × 30	21 × 38
680	10 × 30	12.5 × 30	15 × 30	18 × 38	-
1000	12.5 × 30	12.5 × 30	18 × 30	21 × 38	-
1500	12.5 × 30	15 × 30	18 × 38	-	-
2200	15 × 30	18 × 30	21 × 38	-	-
3300	18 × 30	18 × 38	-	-	-
4700	18 × 38	21 × 38	-	-	-
6800	21 × 38	-	-	-	-

DIMENSIONS in millimeters **AND AVAILABLE FORMS**

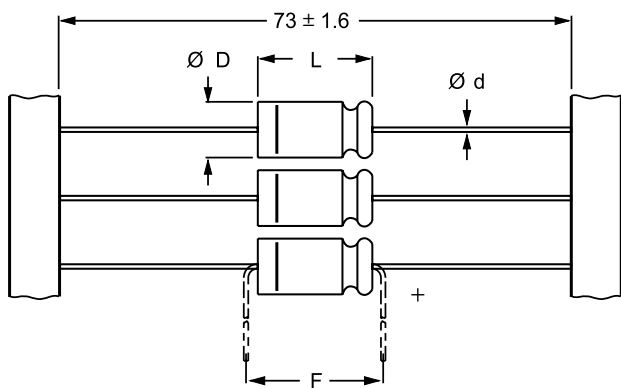

Form BR: Taped on reel,
case $\varnothing D \times L = 10 \times 30$ to 15×30 mm.

Fig.2 **Form BR**

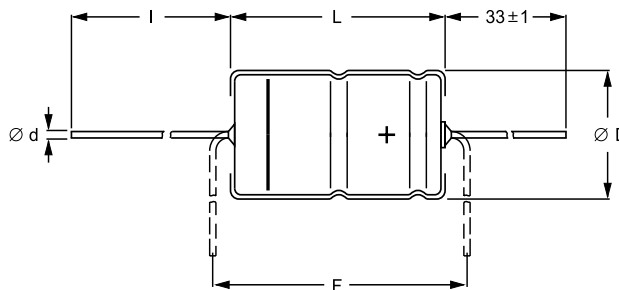

Form AA: Axial in box,
case $\varnothing D \times L = 10 \times 30$ to 21×38 mm

Fig.3 **Form AA**

Table 1

AXIAL; DIMENSIONS in millimeters, MASS AND PACKAGING QUANTITIES								
NOMINAL CASE SIZE $\varnothing D \times L$ (mm)	AXIAL: FORM AA AND BR					MASS (g)	PACKAGING QUANTITIES	
	$\varnothing d^{(1)}$	l	$\varnothing D_{max}$	L _{MAX}	F _{MIN}		FORM AA	FORM BR
10 × 30	0.8	55 ± 1	10.5	30.5	35	≈ 4.8	340	500
12.5 × 30	0.8	55 ± 1	13.0	30.5	35	≈ 7.4	260	400
15 × 30	0.8	55 ± 1	15.5	30.5	35	≈ 11.7	200	250
18 × 30	0.8	55 ± 1	18.5	30.5	35	≈ 12.9	120	-
18 × 38	0.8	34 ± 1	18.5	39.0	44	≈ 19.0	125	-
21 × 38	0.8	34 ± 1	21.5	39.0	44	≈ 24.0	100	-

Note

- Lead diameter $\varnothing d = 1.0$ mm, available on request.
- Detailed tape dimensions see section 'PACKAGING'.

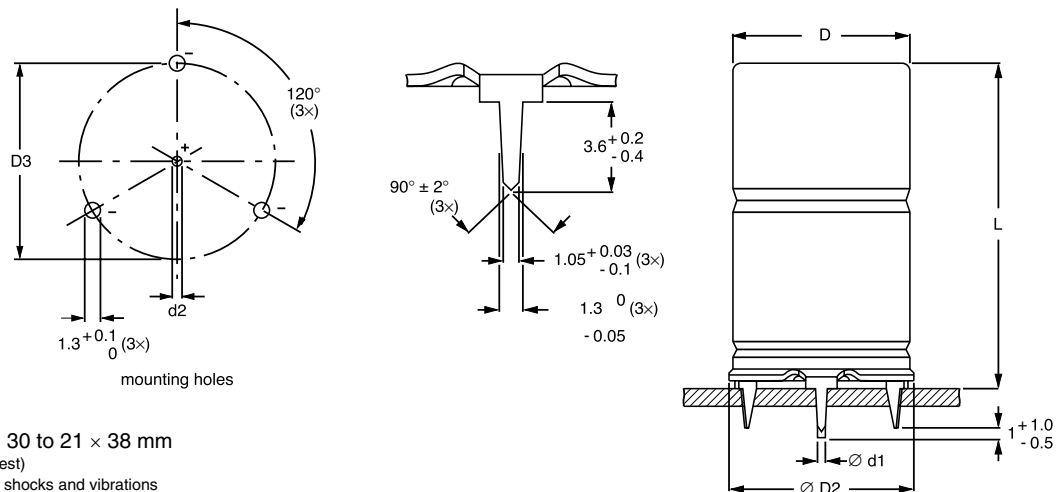
 Fig.4 Mounting hole diagram and outline; **Form MR**; with mounting ring and pins

Form MR: case $\varnothing D \times L = 15 \times 30$ to 21×38 mm
 Case not insulated (insulation on request)
 Especially for applications with severe shocks and vibrations

Table 2

MOUNTING RING; DIMENSIONS in millimeters, MASS AND PACKAGING QUANTITIES									
NOMINAL CASE SIZE $\varnothing D \times L$	CASE CODE	MOUNTING RING: FORM MR						MASS (g)	PACKAGING QUANTITIES
		$\varnothing d1$	$\varnothing d2$	$\varnothing D_{MAX}$	$\varnothing D2_{MAX}$	D3	L _{MAX}		
15 × 30	02	0.8	1.0 + 0.4	15.5	17.5	16.5 ± 0.2	33	≈ 8.6	200
18 × 30	03	0.8	1.0 + 0.4	18.5	19.5	18.5 ± 0.2	33	≈ 11.5	240
18 × 38	04	0.8	1.0 + 0.4	18.5	19.5	18.5 ± 0.2	42	≈ 14.0	100
21 × 38	05	0.8	1.0 + 0.4	21.5	22.5	21.5 ± 0.2	42	≈ 19.2	100



ELECTRICAL DATA	
SYMBOL	DESCRIPTION
C _R	rated capacitance at 100 Hz, tolerance ± 20 %
I _R	rated RMS ripple current at 10 kHz, 125 °C
I _{L1}	max. leakage current after 1 minute at U _R
I _{L5}	max. leakage current after 5 minutes at U _R
ESR	equivalent series resistance at 100 Hz (calculated from tan δ _{max} and C _R)
Z	max. impedance at 10 kHz

ORDERING EXAMPLE*

Electrolytic capacitor 120 series

1000 µF/16 V; ± 20 %

Nominal case size: Ø 12.5 × 30 mm; Form BR

Catalog number: 2222 120 25102

*Note: To ensure delivery of lead (Pb)-free parts during the transition period, please contact your Vishay sales agent.

Note

1. Unless otherwise specified, all electrical values in Table 3 apply at T_{amb} = 20 °C, P = 86 to 106 kPa, RH = 45 to 75 %.

Table 3

ELECTRICAL DATA AND ORDERING INFORMATION													
U _R (V)	C _R 100 Hz (µF)	NOMINAL CASE SIZE Ø D × L (mm)	I _R 10 KHZ 125 °C (mA)	I _{L1} 1 MIN (µA)	I _{L5} 5 MIN (µA)	TYP. ESR 100 Hz (mΩ)	MAX. ESR 100 Hz (mΩ)	TYP. ESR 10 kHz (mΩ)	MAX. ESR 10 kHz (mΩ)	Z MAX. 10 kHz (mΩ)	CATALOG NUMBER 2222 120		
											IN BOX FORM AA	TAPED ON REEL FORM BR	MOUNTING RING FORM MR
16	680	10 × 30	2100	171	84	106	177	44	74	78	15681	25681	-
	1000	12.5 × 30	2550	232	104	77	128	35	58	61	15102	25102	-
	1500	12.5 × 30	2650	328	136	60	100	32	53	53	15152	25152	-
	2200	15 × 30	2940	462	181	48	79	28	46	46	15222	25222	45222
	3300	18 × 30	3430	674	251	41	68	26	43	43	15332	-	45332
	4700	18 × 38	4350	942	341	27	45	18	29	29	15472	-	45472
	6800	21 × 38	4590	1346	475	26	43	18	29	29	15682	-	45682
25	470	10 × 30	2100	181	87	112	187	45	74	84	16471	26471	-
	680	12.5 × 30	2550	244	108	81	136	35	59	64	16681	26681	-
	1000	12.5 × 30	2600	340	140	64	107	32	53	55	16102	26102	-
	1500	15 × 30	2890	490	190	49	82	28	46	46	16152	26152	46152
	2200	18 × 30	3310	700	260	43	71	27	44	44	16222	-	46222
	3300	18 × 38	4350	1030	370	28	47	18	29	29	16332	-	46332
	4700	21 × 38	4470	1450	510	27	44	18	29	29	16472	-	46472
40	220	10 × 30	1990	146	75	192	320	52	87	124	17221	27221	-
	330	12.5 × 30	2430	198	93	130	216	37	62	83	17331	27331	-
	470	12.5 × 30	2550	266	115	101	169	35	58	70	17471	27471	-
	680	15 × 30	2840	366	149	75	125	30	50	55	17681	27681	47681
	1000	18 × 30	3150	520	200	59	99	28	47	49	17102	-	47102
	1500	18 × 38	4130	760	280	39	65	19	31	32	17152	-	47152
	2200	21 × 38	4170	1096	392	34	56	19	31	31	17222	-	47222
63	100	10 × 30	1560	116	65	297	495	92	154	249	18101	28101	-
	150	12.5 × 30	2050	153	78	195	325	61	102	162	18151	28151	-
	220	12.5 × 30	2150	206	95	149	249	55	92	126	18221	28221	-
	330	15 × 30	2510	289	123	105	175	44	73	91	18331	28331	48331
	470	18 × 30	2860	395	158	81	135	38	64	74	18471	-	48471
	680	18 × 38	3720	554	211	55	92	26	43	49	18681	-	48681
	1000	21 × 38	3780	796	292	44	74	25	41	43	18102	-	48102
100	47	10 × 30	760	96	59	760	1269	349	581	720	19479	29479	-
	68	12.5 × 30	1030	122	67	531	885	246	410	503	19689	29689	-
	100	12.5 × 30	1140	160	80	389	648	196	327	381	19101	29101	-
	150	15 × 30	1480	220	100	266	443	137	229	262	19151	29151	49151
	220	18 × 30	1960	304	128	181	302	95	158	179	19221	-	49221
	330	18 × 38	2550	436	172	120	200	62	104	117	19331	-	49331
	470	21 × 38	2800	604	228	92	154	52	86	94	19471	-	49471



Aluminum Capacitors
Axial High Temperature, High Ripple Current

Vishay BCcomponents

ADDITIONAL ELECTRICAL DATA			
PARAMETER	CONDITIONS	VALUE	
		AXIAL	MOUNTING RING
Voltage			
Surge voltage		$U_S \leq 1.15 \times U_R$	
Reverse voltage		$U_{REV} \leq 1 V$	
Current			
Leakage current	after 1 minute at U_R	$I_{L1} \leq 0.012 C_R \times U_R + 40 \mu A$	
	after 5 minutes at U_R	$I_{L5} \leq 0.004 C_R \times U_R + 40 \mu A$	
Inductance			
Equivalent series inductance (ESL)	case $\varnothing D \times L$ mm:		
	10 × 30	typ. 38 nH	
	12.5 × 30	typ. 46 nH	
	15 × 30	typ. 48 nH	typ. 39 nH
	18 × 30	typ. 50 nH	typ. 39 nH
	18 × 38	typ. 54 nH	typ. 39 nH
21 × 38	typ. 59 nH	typ. 39 nH	

CAPACITANCE (C)

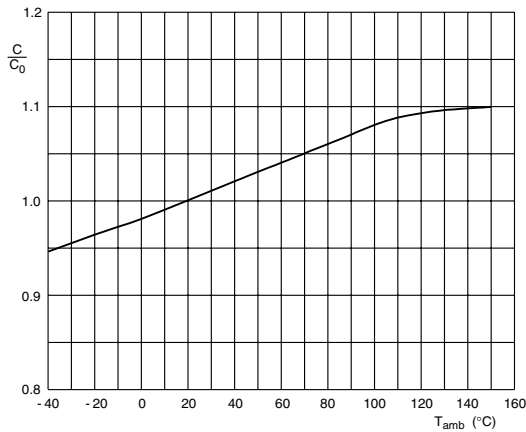

All voltages; all case sizes
 C_0 = capacitance at 20 °C, 100 Hz

Fig.5 Typical multiplier of capacitance as a function of ambient temperature

EQUIVALENT SERIES RESISTANCE (ESR)

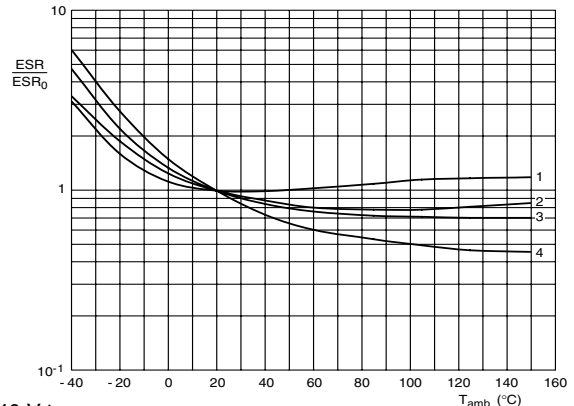

$\leq 40 V$ types
 ESR_0 = typical at 20 °C
Curve 1: All case sizes; 100 Hz
Curve 2: Case $\varnothing D \times L = 18 \times 38$ and 21×38 mm; 10 to 100 kHz
Curve 3: Case $\varnothing D \times L = 15 \times 30$ and 18×30 mm; 10 to 100 kHz
Curve 4: Case $\varnothing D \times L = 10 \times 30$ and 12.5×30 mm; 10 to 100 kHz

Fig.6 Typical multiplier of ESR as a function of ambient temperature at different frequencies

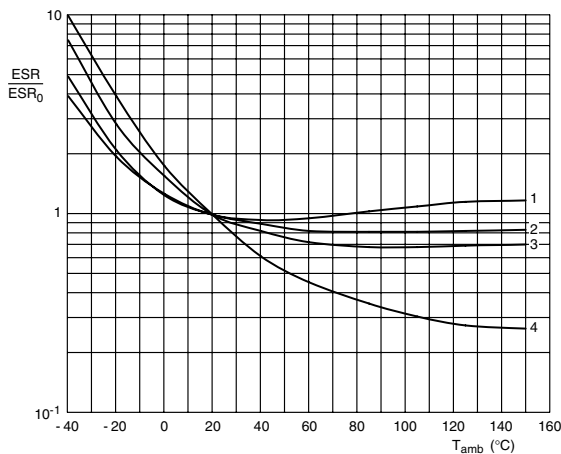

63 V types
 ESR_0 = typical at 20 °C
Curve 1: All case sizes; 100 Hz
Curve 2: Case $\varnothing D \times L = 18 \times 38$ and 21×38 mm; 10 to 100 kHz
Curve 3: Case $\varnothing D \times L = 15 \times 30$ and 18×30 mm; 10 to 100 kHz
Curve 4: Case $\varnothing D \times L = 10 \times 30$ and 12.5×30 mm; 10 to 100 kHz

Fig.7 Typical multiplier of ESR as a function of ambient temperature at different frequencies

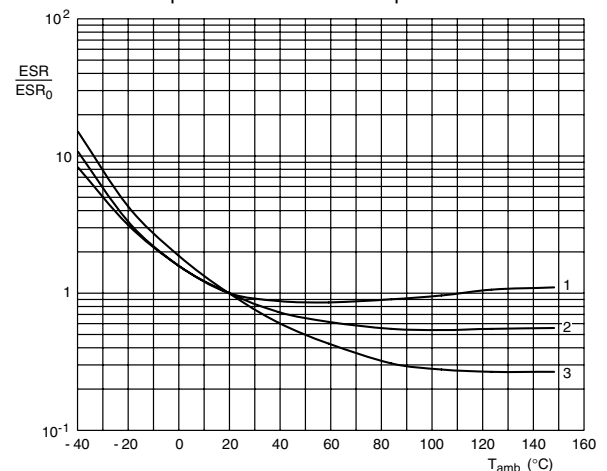

100 V types
 ESR_0 = typical at 20 °C
Curve 1: All case sizes; 100 Hz
Curve 2: Case $\varnothing D \times L = 18 \times 38$ and 21×38 mm; 10 to 100 kHz
Curve 3: Case $\varnothing D \times L = 10 \times 30$ to 18×30 mm; 10 to 100 kHz

Fig.8 Typical multiplier of ESR as a function of ambient temperature at different frequencies

RIPPLE CURRENT AND USEFUL LIFE

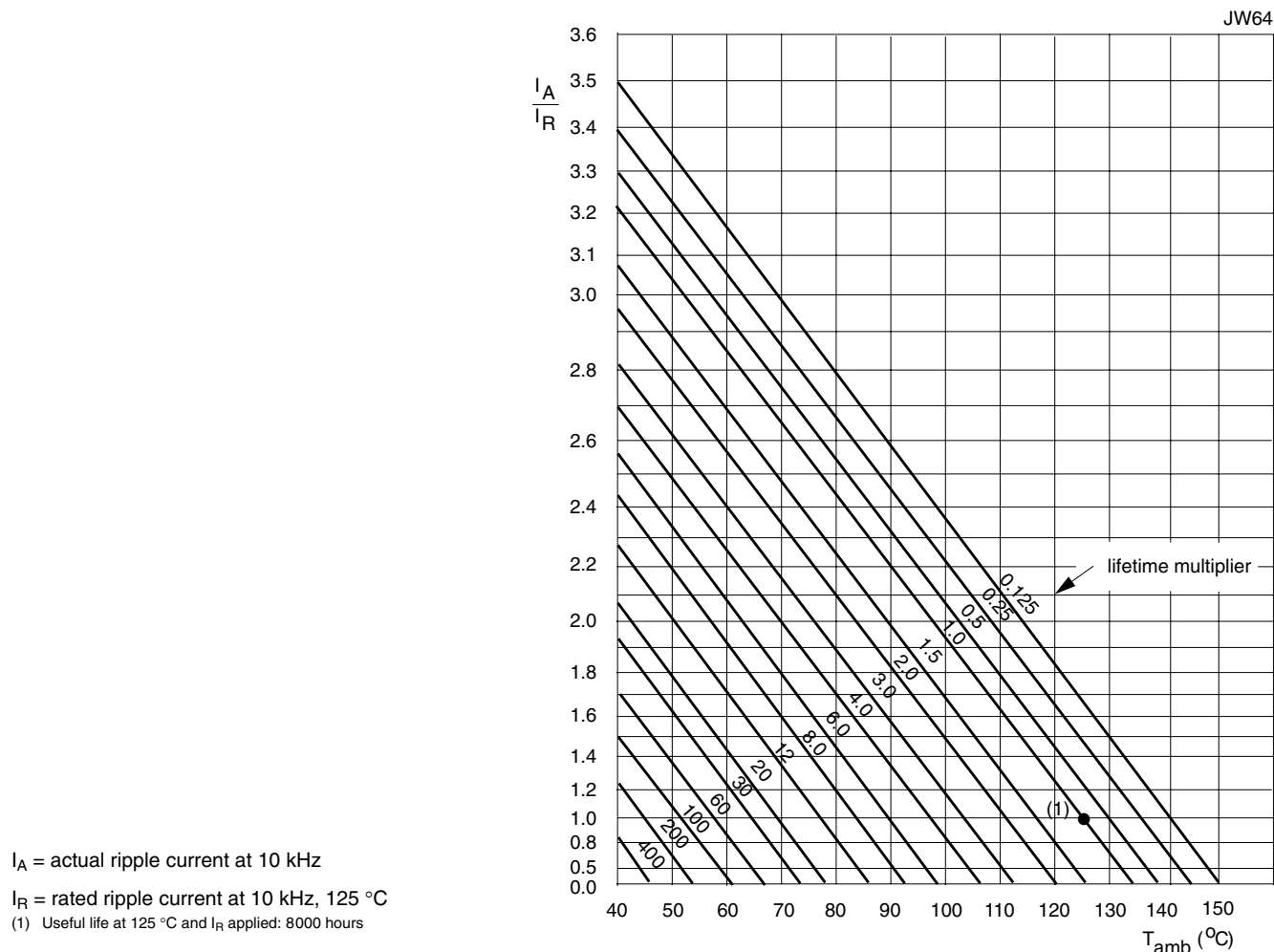

Fig.9 Multiplier of useful life as a function of ambient temperature and ripple current load

Table 4

MULTIPLIER OF RIPPLE CURRENT (I_R) AS A FUNCTION OF FREQUENCY				
FREQUENCY (Hz)	I_R MULTIPLIER			
	$U_R = 16$ to 40 V case sizes 10×30 to 15×30 mm	$U_R = 16$ to 40 V case sizes 18×30 to 21×38 mm	$U_R = 63$ and 100 V case sizes 10×30 to 15×30 mm	$U_R = 63$ and 100 V case sizes 18×30 to 21×38 mm
50	0.37	0.54	0.23	0.44
100	0.48	0.63	0.32	0.56
300	0.69	0.75	0.53	0.76
1000	0.86	0.81	0.77	0.88
3000	0.96	0.87	0.93	0.94
≥ 10000	1.00	1.00	1.00	1.00



Aluminum Capacitors
Axial High Temperature, High Ripple Current

Table 5

TEST PROCEDURES AND REQUIREMENTS			
TEST		PROCEDURE (QUICK REFERENCE)	REQUIREMENTS
NAME OF TEST	REFERENCE		
Endurance	IEC 60384-4/ EN130300 subclause 4.13	$T_{amb} = 125\text{ }^{\circ}\text{C}$; U_R applied; 4000 hours $T_{amb} = 150\text{ }^{\circ}\text{C}$; U_R applied; 1000 hours	$\Delta C/C: \pm 15\%$ $\tan \delta \leq 1.3 \times \text{spec. limit}$ $Z \leq 2 \times \text{spec. limit}$ $I_{L5} \leq \text{spec. limit}$
Useful life	CECC 30301 subclause 1.8.1	$T_{amb} = 125\text{ }^{\circ}\text{C}$; U_R and I_R applied; 8000 hours	$\Delta C/C: \pm 45\%$ $\tan \delta \leq 3 \times \text{spec. limit}$ $Z \leq 3 \times \text{spec. limit}$ $I_{L5} \leq \text{spec. limit}$ no short or open circuit total failure percentage: $\leq 1\%$
Shelf life (storage at high temperature)	IEC 60384-4/ EN130300 subclause 4.17	$T_{amb} = 125\text{ }^{\circ}\text{C}$; no voltage applied; 1000 hours (100 V: 500 hours) $T_{amb} = 150\text{ }^{\circ}\text{C}$; no voltage applied; 500 hours for voltages: $\leq 63\text{ V}$ after test: U_R to be applied for 30 minutes, 24 to 48 hours before measurement	$\Delta C/C, \tan \delta, Z$: for requirements see 'Endurance test' above $I_{L5} \leq 2 \times \text{spec. limit}$
Reverse voltage	IEC 60384-4/ EN130300 subclause 4.15	$T_{amb} = 125\text{ }^{\circ}\text{C}$: 125 hours at $U = -1\text{ V}$ followed by 125 hours at U_R	$\Delta C/C: \pm 20\%$ $\tan \delta \leq \text{spec. limit}$ $I_{L5} \leq \text{spec. limit}$
Vibration	IEC 60068-2 subclause 4.15 test method Fc	10 to 2000 Hz; 1.5 mm or 20 g (whichever is less severe); in 3 directions; 2.5 hours per direction	no visible damage; no leakage of electrolyte; markings legible $\Delta C/C: \pm 5\%$ with respect to initial measurement



Notice

Specifications of the products displayed herein are subject to change without notice. Vishay Intertechnology, Inc., or anyone on its behalf, assumes no responsibility or liability for any errors or inaccuracies.

Information contained herein is intended to provide a product description only. No license, express or implied, by estoppel or otherwise, to any intellectual property rights is granted by this document. Except as provided in Vishay's terms and conditions of sale for such products, Vishay assumes no liability whatsoever, and disclaims any express or implied warranty, relating to sale and/or use of Vishay products including liability or warranties relating to fitness for a particular purpose, merchantability, or infringement of any patent, copyright, or other intellectual property right.

The products shown herein are not designed for use in medical, life-saving, or life-sustaining applications. Customers using or selling these products for use in such applications do so at their own risk and agree to fully indemnify Vishay for any damages resulting from such improper use or sale.