

## Aluminum Capacitors Power Economic Printed Wiring

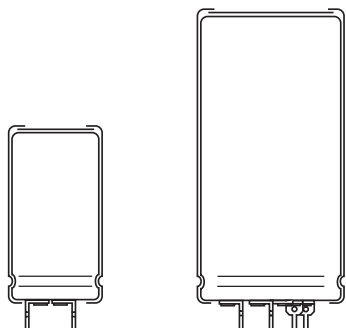
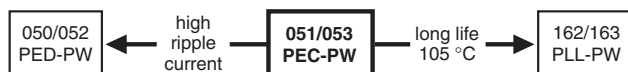

Fig. 1 Component outlines.



QUICK REFERENCE DATA		
DESCRIPTION	VALUE	
	051	053
Nominal case size (ØD x L in mm)	25 x 30 to 40 x 100	
Rated capacitance range (E6 series), C <sub>R</sub>	680 to 150000 µF	68 to 2200 µF
Tolerance on C <sub>R</sub>	±20%	
Rated voltage range, U <sub>R</sub>	10 to 100 V	200 to 400 V
Category temperature range	-40 to +85 °C	
Endurance test at 85 °C	5000 hours	
Useful life at 85 °C	12000 hours	
Useful life at 40 °C, 1.4 x IR applied	200000 hours	
Shelf life at 0 V, 85 °C	500 hours	
Based on sectional specification	IEC 60384-4/EN130300	
Climatic category IEC 60068	40/085/56	

### FEATURES

- Polarized aluminum electrolytic capacitors, non-solid electrolyte
- Large types with reduced dimensions, cylindrical aluminum case, insulated with a blue sleeve
- Provided with keyed polarity
- Long useful life: 12000 hours at 85 °C
- High ripple current capability
- High resistance to shock and vibration.

### APPLICATIONS

- General purpose, industrial and audio/video systems
- Smoothing and filtering
- Standard and switched mode power supplies
- Energy storage in pulse systems.

### MARKING

The capacitors are marked (where possible) with the following information:

- Rated capacitance (in µF).
- Tolerance on rated capacitance, code letter in accordance with IEC 60062 (M for ±20%).
- Rated voltage (in V).
- Date code (YYMM).
- Name of manufacturer.
- Code for factory of origin.
- Polarity of the terminals and ‘-’ sign to indicate the negative terminal, visible from the top and/or side of the capacitor.
- Code number.
- Climatic category in accordance with IEC 60068.

SELECTION CHART FOR C <sub>R</sub> , U <sub>R</sub> AND RELEVANT NOMINAL CASE SIZES (ØD x L in mm)									
C <sub>R</sub> (µF)	U <sub>R</sub> (V)								
	10	16	25	40	63	100	200	385	400
68	-	-	-	-	-	-	-	25 x 30	25 x 30
100	-	-	-	-	-	-	-	25 x 40	25 x 40
150	-	-	-	-	-	-	25 x 30	30 x 40	30 x 40
220	-	-	-	-	-	-	25 x 40	35 x 40	35 x 40
330	-	-	-	-	-	-	30 x 40	35 x 50	35 x 50
	-	-	-	-	-	-	-	40 x 40	40 x 40
470	-	-	-	-	-	-	35 x 40	40 x 50	40 x 50
	-	-	-	-	-	-	25 x 30	35 x 50	40 x 70
680	-	-	-	-	-	-	40 x 40	-	-
	-	-	-	-	-	-	25 x 40	40 x 50	40 x 100
1000	-	-	-	-	-	-	30 x 40	40 x 70	-
1500	-	-	-	-	-	-	-	-	-
2200	-	-	-	-	25 x 30	35 x 40	40 x 100	-	-

$C_R$ ( $\mu F$ )	$U_R$ (V)								
	10	16	25	40	63	100	200	385	400
3300	-	-	-	25 × 30	25 × 40	35 × 50	-	-	-
4700	-	-	25 × 30	25 × 40	30 × 40	40 × 50	-	-	-
6800	-	25 × 30	25 × 40	30 × 40	35 × 40	40 × 70	-	-	-
10000	25 × 30	25 × 40	30 × 40	35 × 40	35 × 50	40 × 100	-	-	-
15000	25 × 40	30 × 40	35 × 40	35 × 50	40 × 70	-	-	-	-
22000	30 × 40	35 × 40	35 × 50	40 × 50	40 × 100	-	-	-	-
33000	35 × 40	35 × 50	40 × 50	40 × 70	-	-	-	-	-
47000	35 × 50	40 × 50	40 × 70	40 × 100	-	-	-	-	-
68000	40 × 50	40 × 70	40 × 100	-	-	-	-	-	-
100000	40 × 70	40 × 100	-	-	-	-	-	-	-
150000	40 × 100	-	-	-	-	-	-	-	-

**DIMENSIONS** in millimeters **AND AVAILABLE FORMS**

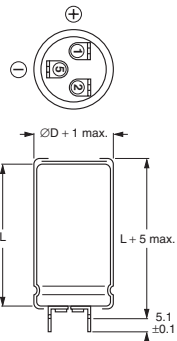

1 = positive terminal; 5 = negative terminal.  
Case  $\varnothing D = 25$  mm.

Fig.2 Printed wiring pin version.

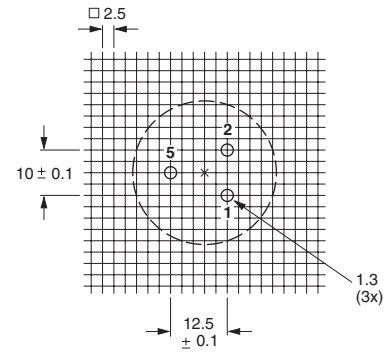

Case  $\varnothing D = 25$  mm.

Fig.3 Mounting hole diagram viewed from component side.

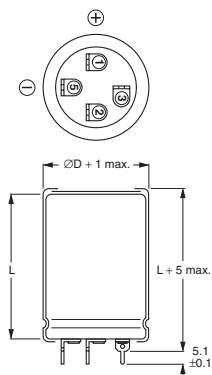

1 = positive terminal; 5 = negative terminal.  
Case  $\varnothing D = 30$  mm.

Fig.4 Printed wiring pin version.

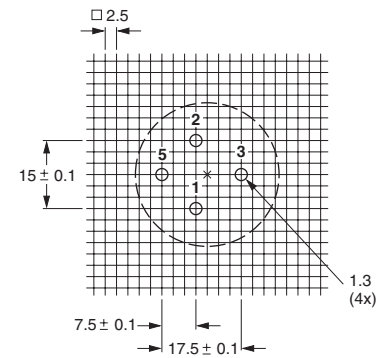

Case  $\varnothing D = 30$  mm.

Fig.5 Mounting hole diagram viewed from component side.

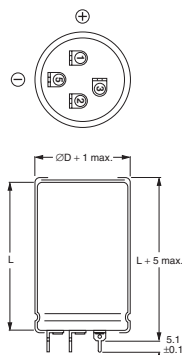

1 = positive terminal; 5 = negative terminal.  
Case  $\varnothing D = 35 \text{ mm}$ .

Fig.6 Printed wiring pin version.

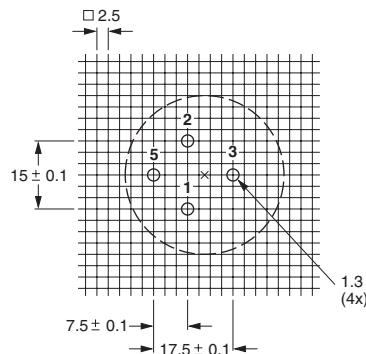

Case  $\varnothing D = 35 \text{ mm}$ .

Fig.7 Mounting hole diagram viewed from component side.

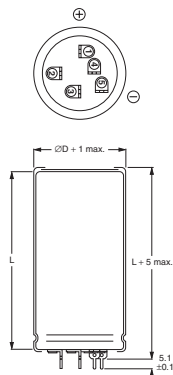

1 = positive terminal; 5 = negative terminal.  
Case  $\varnothing D = 40 \text{ mm}$ .

Fig.8 Printed wiring pin version.

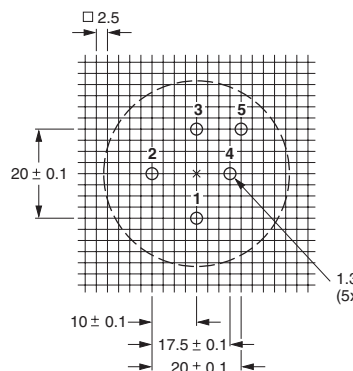

Case  $\varnothing D = 40 \text{ mm}$ .

Fig.9 Mounting hole diagram viewed from component side.

Table 1

DIMENSIONS in millimeters, MASS AND PACKAGING QUANTITIES PW versions					
NOMINAL CASE SIZE $\varnothing D \times L$	$\varnothing D_{\text{max}}$	$L_{\text{max}}$	MASS (g)	PACKAGING QUANTITIES (units per box)	CARDBOARD BOX DIMENSIONS $L \times W \times H$
25 × 30	26	35	≈24	100	290 × 280 × 50
25 × 40	26	45	≈28	100	290 × 280 × 60
30 × 40	31	45	≈38	100	340 × 330 × 60
35 × 40	36	45	≈51	50	390 × 198 × 60
35 × 50	36	55	≈66	50	390 × 198 × 70
40 × 40	41	45	≈78	50	440 × 223 × 60
40 × 50	41	55	≈82	50	440 × 223 × 70
40 × 70	41	75	≈110	25	230 × 230 × 90
40 × 100	41	105	≈176	25	230 × 230 × 120

**MOUNTING**

When a number of capacitors are connected in a bank, they must not be closer together than 15 mm, when no derating of ripple current and/or temperature is applied.

**Pin numbers 2, 3 and 4 (if present) must be free from the electrical circuit.**



ELECTRICAL DATA	
SYMBOL	DESCRIPTION
C <sub>R</sub>	rated capacitance at 100 Hz
I <sub>R</sub>	rated RMS ripple current at 100 Hz, 85 °C or at 20 kHz, 70 °C
I <sub>L1</sub>	max. leakage current after 1 minute at U <sub>R</sub>
I <sub>L5</sub>	max. leakage current after 5 minutes at U <sub>R</sub>
ESR	max. equivalent series resistance at 100 Hz
Z	max. impedance at 10 kHz

**ORDERING EXAMPLE**

Electrolytic capacitor 051 series  
10000 µF/25 V; ±20%  
Nominal case size: Ø30 × 40 mm  
Catalog number: 2222 051 56103.

**Note**

1. Unless otherwise specified, all electrical values in Tables 2 and 3 apply at T<sub>amb</sub> = 20 °C, P = 86 to 106 kPa, RH = 45 to 75%

Table 2

ELECTRICAL DATA AND ORDERING INFORMATION 051 SERIES									
U <sub>R</sub> (V)	C <sub>R</sub> 100 Hz (µF)	NOMINAL CASE SIZE ØD × L (mm)	I <sub>R</sub> 100 Hz 85 °C (A)	I <sub>R</sub> 20 kHz 70 °C (A)	I <sub>L1</sub> 1 min (mA)	I <sub>L5</sub> 5 min (mA)	ESR 100 Hz (mΩ)	Z 10 kHz (mΩ)	CATALOG NUMBER 2222 ... ..
10	10000	25 × 30	3.1	5.9	0.60	0.20	51	40	051 54103
	15000	25 × 40	4.1	7.8	0.90	0.30	37	30	051 54153
	22000	30 × 40	5.0	9.5	1.32	0.44	30	25	051 54223
	33000	35 × 40	5.5	10.4	1.98	0.66	28	24	051 54333
	47000	35 × 50	6.8	12.9	2.82	0.94	23	20	051 54473
	47000	40 × 40	5.8	10.4	2.82	0.94	29	22	051 44473
	68000	40 × 50	7.1	13.5	4.08	1.36	24	20	051 54683
	100000	40 × 70	9.2	17.4	6.00	2.00	19	16	051 54104
16	150000	40 × 100	12.0	22.7	9.00	3.00	16	14	051 54154
	6800	25 × 30	3.1	5.9	0.65	0.22	53	42	051 55682
	10000	25 × 40	4.0	7.6	0.96	0.32	39	34	051 55103
	15000	30 × 40	5.0	9.5	1.44	0.48	31	27	051 55153
	22000	35 × 40	5.5	10.4	2.12	0.71	29	26	051 55223
	33000	35 × 50	6.7	12.7	3.17	1.06	23	21	051 55333
	33000	40 × 40	5.7	10.8	3.17	1.06	30	24	051 45333
	47000	40 × 50	7.0	13.3	4.52	1.51	24	20	051 55473
25	68000	40 × 70	9.2	17.4	6.53	2.18	19	16	051 55683
	100000	40 × 100	12.0	22.7	9.60	3.20	16	14	051 55104
	4700	25 × 30	2.9	5.5	0.71	0.24	60	42	051 56472
	6800	25 × 40	3.9	7.4	1.02	0.34	42	34	051 56682
	10000	30 × 40	4.8	9.1	1.50	0.50	34	27	051 56103
	15000	35 × 40	5.3	10.0	2.25	0.75	30	26	051 56153
	22000	35 × 50	6.5	12.3	3.30	1.10	24	21	051 56223
	22000	40 × 40	5.7	10.8	3.30	1.10	31	24	051 46223
40	33000	40 × 50	7.0	13.3	4.95	1.65	25	20	051 56333
	47000	40 × 70	9.2	17.4	7.05	2.35	19	16	051 56473
	68000	40 × 100	12.0	22.7	10.20	3.40	16	14	051 56683
	3300	25 × 30	2.9	5.5	0.80	0.27	87	63	051 57332
	4700	25 × 40	3.8	7.2	1.13	0.38	62	47	051 57472
	6800	30 × 40	4.7	8.9	1.64	0.55	49	38	051 57682
	10000	35 × 40	5.2	9.8	2.40	0.80	48	37	051 57103
	15000	35 × 50	6.3	11.9	3.60	1.20	37	28	051 57153
40	15000	40 × 40	5.6	10.6	3.60	1.20	50	35	051 47153
	22000	40 × 50	5.8	11.0	5.28	1.76	39	28	051 57223
	33000	40 × 70	7.8	14.8	7.92	2.64	28	21	051 57333
	47000	40 × 100	10.4	19.7	11.28	3.76	22	17	051 57473

<b>ELECTRICAL DATA AND ORDERING INFORMATION 051 SERIES</b>									
$U_R$ (V)	$C_R$ 100 Hz ( $\mu$ F)	NOMINAL CASE SIZE $\varnothing D \times L$ (mm)	$I_R$ 100 Hz 85 °C (A)	$I_R$ 20 kHz 70 °C (A)	$I_{L1}$ 1 min (mA)	$I_{L5}$ 5 min (mA)	ESR 100 Hz (m $\Omega$ )	Z 10 kHz (m $\Omega$ )	CATALOG NUMBER 2222 ... ..
63	2200	25 × 30	2.5	4.7	0.84	0.28	83	62	051 58222
	3300	25 × 40	3.3	6.2	1.25	0.42	58	42	051 58332
	4700	30 × 40	4.1	7.8	1.78	0.60	49	38	051 58472
	6800	35 × 40	4.5	8.5	2.57	0.86	48	37	051 58682
	10000	35 × 50	5.4	10.2	3.78	1.26	37	28	051 58103
	10000	40 × 40	4.6	8.7	3.78	1.26	52	37	051 48103
	15000	40 × 70	7.5	14.2	5.67	1.89	29	24	051 58153
	22000	40 × 100	10.0	19.0	8.32	2.77	22	19	051 58223
100	680	25 × 30	1.74	3.30	0.41	0.14	190	130	051 59681
	1000	25 × 40	2.34	4.44	0.60	0.20	130	90	051 59102
	1500	30 × 40	2.95	5.59	0.90	0.30	95	67	051 59152
	2200	35 × 40	3.69	7.00	1.32	0.44	71	53	051 59222
	3300	35 × 50	4.37	8.29	1.98	0.66	55	41	051 59332
	3300	40 × 40	4.16	7.89	1.98	0.66	64	48	051 49332
	4700	40 × 50	5.21	9.88	2.82	0.94	49	38	051 59472
	6800	40 × 70	6.97	13.22	4.08	1.36	35	28	051 59682
	10000	40 × 100	9.50	18.00	6.00	2.00	26	21	051 59103

Table 3

<b>ELECTRICAL DATA AND ORDERING INFORMATION 053 SERIES</b>									
$U_R$ (V)	$C_R$ 100 Hz ( $\mu$ F)	NOMINAL CASE SIZE $\varnothing D \times L$ (mm)	$I_R$ 100 Hz 85 °C (A)	$I_R$ 20 kHz 70 °C (A)	$I_{L1}$ 1 min (mA)	$I_{L5}$ 5 min (mA)	ESR 100 Hz (m $\Omega$ )	Z 10 kHz (m $\Omega$ )	CATALOG NUMBER 2222 ... ..
200	150	25 × 30	0.70	1.33	0.18	0.06	1000	770	053 52151
	220	25 × 40	0.94	1.78	0.26	0.09	680	525	053 52221
	330	30 × 40	1.27	2.41	0.40	0.14	460	360	053 52331
	470	35 × 40	1.66	3.15	0.57	0.19	320	250	053 52471
	680	35 × 50	2.19	4.15	0.82	0.28	220	170	053 52681
	680	40 × 40	2.17	4.11	0.82	0.28	220	170	053 42681
	1000	40 × 50	2.86	5.42	1.20	0.40	150	115	053 52102
	1500	40 × 70	3.81	7.22	1.80	0.60	110	85	053 52152
2200	40 × 100	5.20	9.86	2.64	0.88	80	60	053 52222	
385	68	25 × 30	0.47	0.89	0.16	0.06	2200	1480	053 58689
	100	25 × 40	0.64	1.21	0.23	0.08	1500	1020	053 58101
	150	30 × 40	0.90	1.71	0.35	0.12	1000	700	053 58151
	220	35 × 40	1.15	2.18	0.51	0.17	680	480	053 58221
	330	35 × 50	1.53	2.90	0.77	0.26	450	340	053 58331
	330	40 × 40	1.52	2.88	0.77	0.26	450	340	053 48331
	470	40 × 50	1.96	3.72	1.09	0.36	320	260	053 58471
	680	40 × 70	2.70	5.12	1.58	0.53	220	190	053 58681
1000	40 × 100	3.70	7.02	2.31	0.78	180	140	053 58102	
400	68	25 × 30	0.54	1.02	0.16	0.06	2100	1000	053 56689
	100	25 × 40	0.73	1.38	0.24	0.08	1400	780	053 56101
	150	30 × 40	0.98	1.86	0.36	0.12	950	520	053 56151
	220	35 × 40	1.28	2.43	0.52	0.17	650	400	053 56221
	330	35 × 50	1.67	3.17	0.79	0.26	480	280	053 56331
	330	40 × 40	1.67	3.17	0.79	0.26	480	280	053 46331
	470	40 × 50	2.12	4.02	1.12	0.37	340	220	053 56471
	680	40 × 70	2.90	5.50	1.63	0.54	235	155	053 56681
	1000	40 × 100	4.05	7.68	2.40	0.80	160	110	053 56102



ADDITIONAL ELECTRICAL DATA		
PARAMETER	CONDITIONS	VALUE
<b>Voltage</b>		
Surge voltage	≤ 250 V versions	$U_s = 1.15 \times U_R$
	≥ 385 V versions	$U_s = 1.1 \times U_R$
Reverse voltage		$U_{rev} \leq 1 \text{ V}$
<b>Current</b>		
Leakage current	after 1 minute at $U_R$	$I_{L1} \leq 0.006 C_R \times U_R + 4 \mu\text{A}$
	after 5 minutes at $U_R$	$I_{L5} \leq 0.002 C_R \times U_R + 4 \mu\text{A}$
<b>Inductance</b>		
Equivalent series inductance (ESL)	case $\varnothing D = 25 \text{ mm}$	max. 25 nH
	case $\varnothing D = 30 \text{ and } 35 \text{ mm}$	max. 30 nH
	case $\varnothing D = 40 \text{ mm}$	max. 35 nH

**CAPACITANCE (C)**

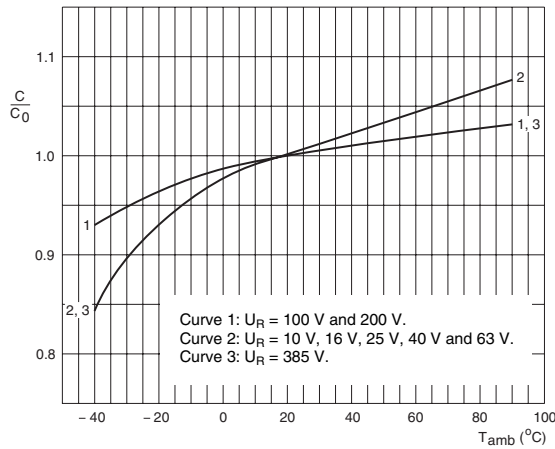

$C_0$  = capacitance at 20 °C and 100 Hz.

Fig.10 Typical multiplier of capacitance as a function of ambient temperature.

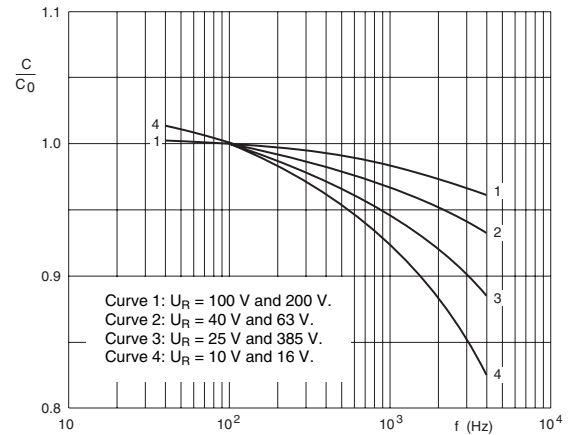

$C_0$  = capacitance at 20 °C and 100 Hz.

Fig.11 Typical multiplier of capacitance as a function of frequency.

**EQUIVALENT SERIES RESISTANCE (ESR)**

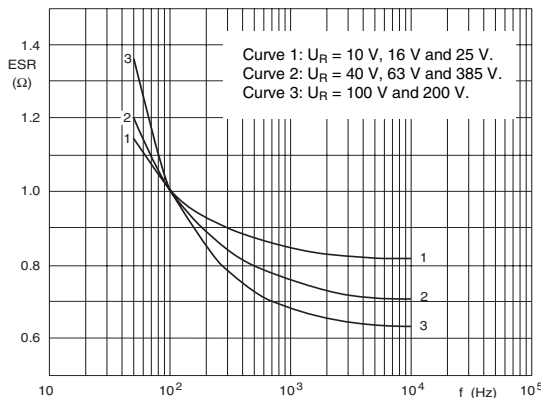

$ESR_0$  = typical at 20 °C and 100 Hz.

Fig.12 Typical multiplier of typical ESR as a function of frequency.

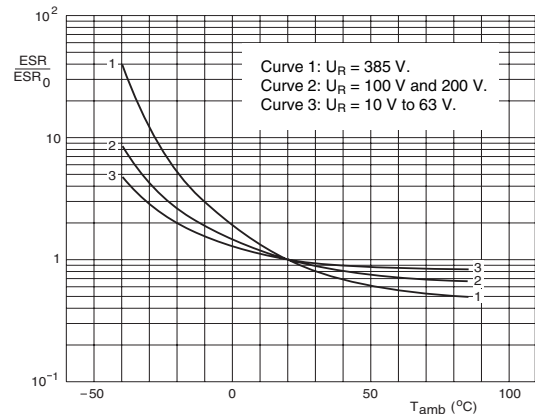

$ESR_0$  = typical at 20 °C and 100 Hz.

Case  $\varnothing D \times L = 25 \times 30, 25 \times 40, 30 \times 40, \text{ and } 35 \times 40 \text{ mm}$ .  
Fig.13 Typical multiplier of ESR as a function of ambient temperature.



**EQUIVALENT SERIES RESISTANCE (ESR)**

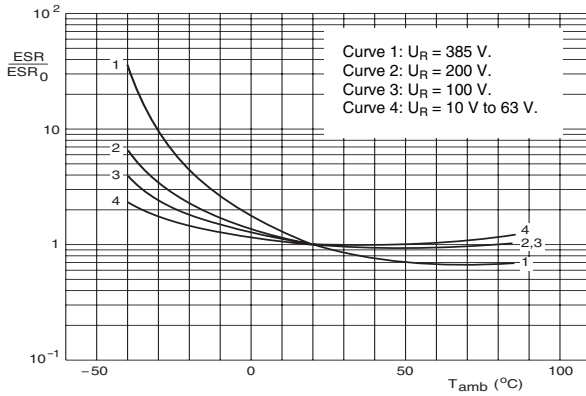

Case ØD × L = 35 × 50, 40 × 40, 40 × 50, 40 × 70 and 40 × 100 mm.  
ESR<sub>0</sub> = typical at 20 °C and 100 Hz.

Fig.14 Typical multiplier of ESR as a function of ambient temperature.

**IMPEDANCE (Z)**

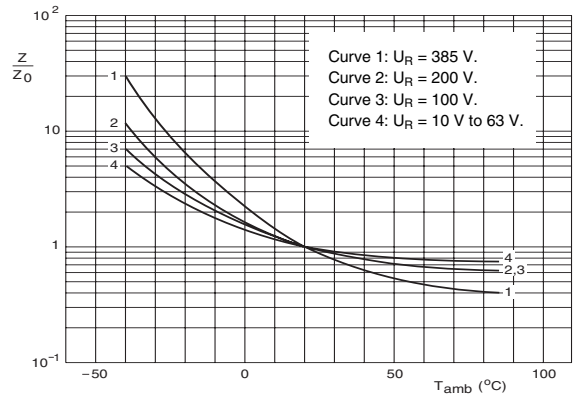

Case ØD × L = 25 × 30, 25 × 40, 30 × 40 and 35 × 40 mm.  
Z<sub>0</sub> = typical impedance at 20 °C and 10 kHz.

Fig.15 Typical multiplier of impedance as a function of ambient temperature.

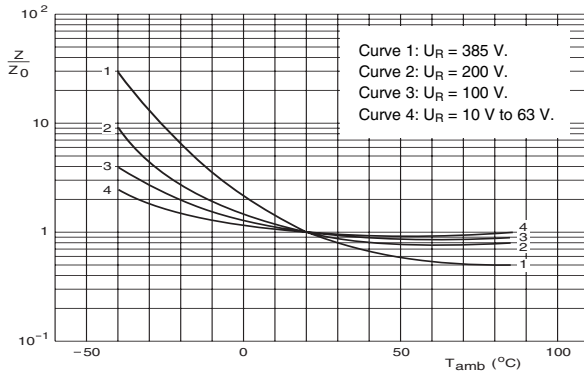

Case ØD × L = 35 × 50, 40 × 40, 40 × 50, 40 × 70 and 40 × 100 mm.  
Z<sub>0</sub> = typical impedance at 20 °C and 10 kHz.

Fig.16 Typical multiplier of impedance as a function of ambient temperature.

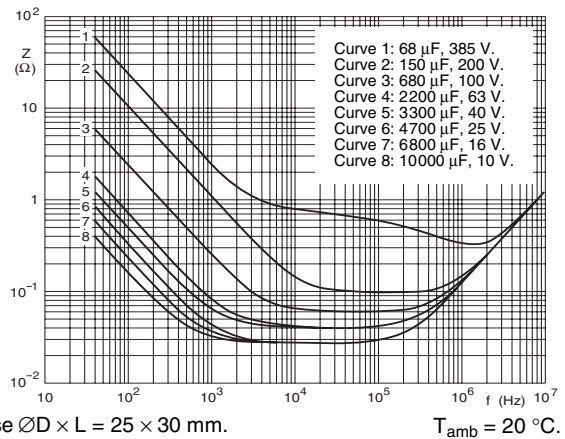

Case ØD × L = 25 × 30 mm.

Fig.17 Typical impedance as a function of frequency.

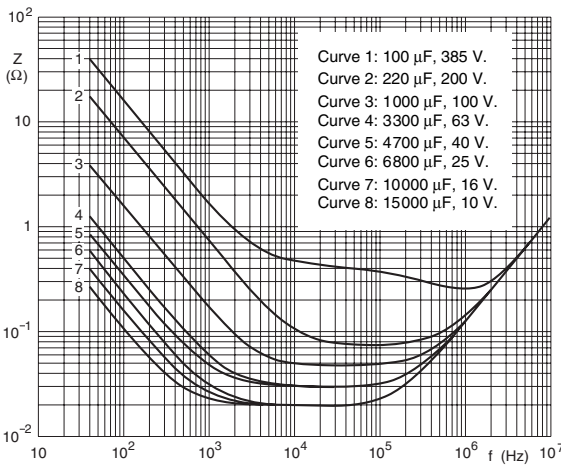

Case ØD × L = 25 × 40 mm.

Fig.18 Typical impedance as a function of frequency.

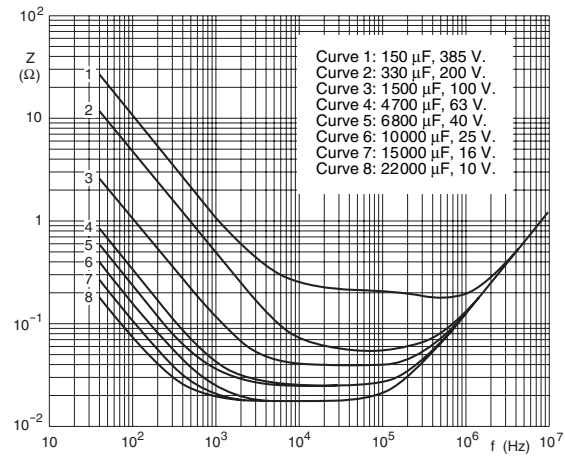

Case ØD × L = 30 × 40 mm.

Fig.19 Typical impedance as a function of frequency.



**IMPEDANCE (Z)**

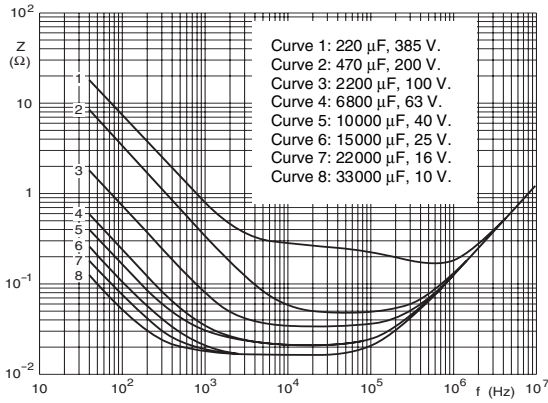

Case  $\text{ØD} \times \text{L} = 35 \times 40 \text{ mm}$ .  $T_{\text{amb}} = 20 \text{ }^\circ\text{C}$ .  
Fig.20 Typical impedance as a function of frequency.

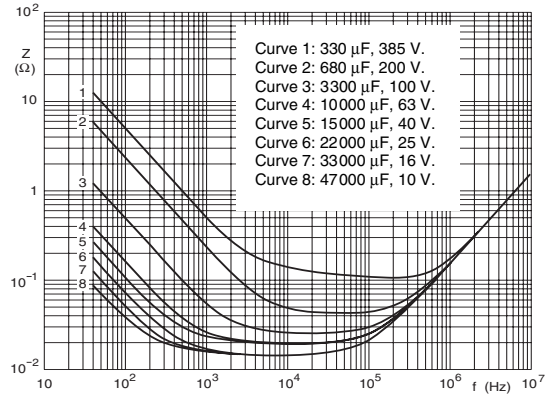

Case  $\text{ØD} \times \text{L} = 35 \times 50$  and  $40 \times 40 \text{ mm}$ .  $T_{\text{amb}} = 20 \text{ }^\circ\text{C}$ .  
Fig.21 Typical impedance as a function of frequency.

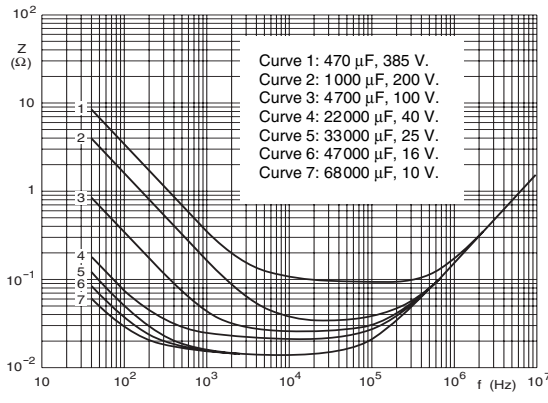

Case  $\text{ØD} \times \text{L} = 40 \times 50 \text{ mm}$ .  $T_{\text{amb}} = 20 \text{ }^\circ\text{C}$ .  
Fig.22 Typical impedance as a function of frequency.

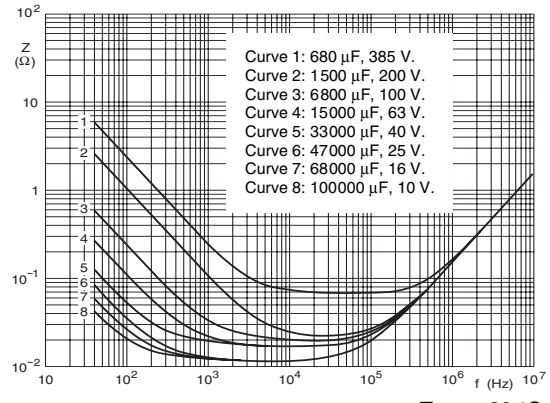

Case  $\text{ØD} \times \text{L} = 40 \times 70 \text{ mm}$ .  $T_{\text{amb}} = 20 \text{ }^\circ\text{C}$ .  
Fig.23 Typical impedance as a function of frequency.

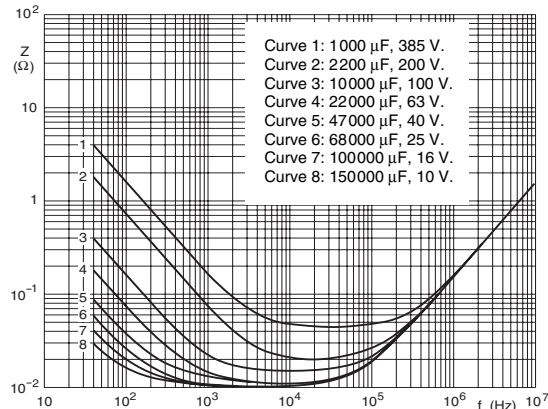

Case  $\text{ØD} \times \text{L} = 40 \times 100 \text{ mm}$ .  $T_{\text{amb}} = 20 \text{ }^\circ\text{C}$ .  
Fig.24 Typical impedance as a function of frequency.



**RIPPLE CURRENT AND USEFUL LIFE**

$I_A$  = actual ripple current at 100 Hz.  
 $I_R$  = rated ripple current at 100 Hz and 85 °C.  
 (1) Useful life at 85 °C and  $I_R$  applied: 12000 hours.

Fig.25 Multiplier of useful life as a function of ambient temperature and ripple current load.

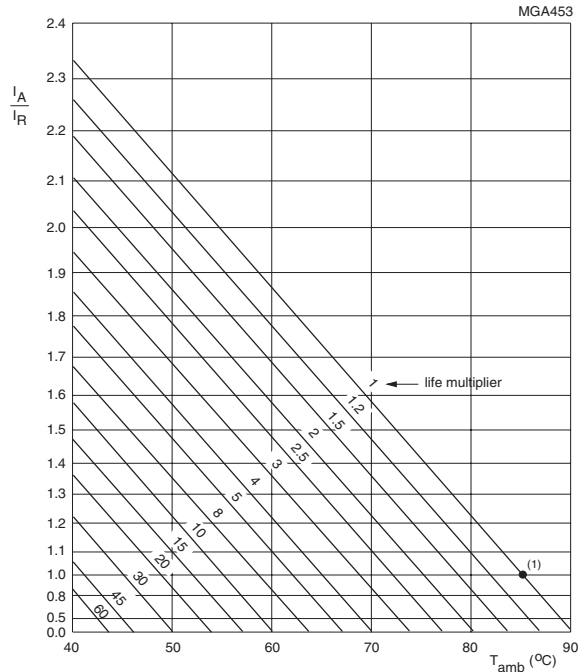

Table 4

MULTIPLIER OF RIPPLE CURRENT ( $I_R$ ) AS A FUNCTION OF FREQUENCY	
FREQUENCY (Hz)	$I_R$ MULTIPLIER
50	0.83
100	1.00
200	1.10
400	1.15
1000	1.19
≥ 2000	1.20

Table 5

TEST PROCEDURES AND REQUIREMENTS			
TEST		PROCEDURE (quick reference)	REQUIREMENTS
NAME OF TEST	REFERENCE		
Endurance	IEC 60384-4/ EN130300 subclause 4.13	$T_{amb} = 85\text{ °C}$ ; $U_R$ applied; 5000 hours	$U_R \leq 100\text{ V}$ ; $\Delta C/C: \pm 15\%$ $U_R > 100\text{ V}$ ; $\Delta C/C: \pm 10\%$ $ESR \leq 1.3 \times \text{spec. limit}$ $Z \leq 2 \times \text{spec. limit}$ $I_{L5} \leq \text{spec. limit}$
Useful life	CECC 30301 subclause 1.8.1	$T_{amb} = 85\text{ °C}$ ; $U_R$ and $I_R$ applied; 12000 hours	$U_R \leq 100\text{ V}$ ; $\Delta C/C: \pm 45\%$ $U_R > 100\text{ V}$ ; $\Delta C/C: \pm 30\%$ $ESR \leq 3 \times \text{spec. limit}$ $Z \leq 3 \times \text{spec. limit}$ $I_{L5} \leq \text{spec. limit}$ no short or open circuit, no visible damage total failure percentage: $U_R \leq 100\text{ V}: \leq 1\%$ ; $U_R > 100\text{ V}: \leq 3\%$
Shelf life (storage at high temperature)	IEC 60384-4/ EN130300 subclause 4.17	$T_{amb} = 85\text{ °C}$ ; no voltage applied; 500 hours after test: $U_R$ to be applied for 30 minutes, 24 to 48 hours before measurement	$\Delta C/C: \pm 10\%$ $ESR \leq 1.2 \times \text{spec. limit}$ $I_{L5} \leq 2 \times \text{spec. limit}$