

## The Best Relaytion



## MT4 Relay



# MT4 Relay

**AXICOM**

4 pole telecom/signal relay  
Through Hole Type (THT)  
Non-polarized, non-latching 1 coil

## Features

- Telecom/signal relay (dry circuit, test access, ringing)
- 20 x 14.8 mm, 0.795 x 0.582 inch
- Switching current 1.25 A
- 4 changeover contacts (4 form C / 4PDT)
- Bifurcated contacts
- Meets Bellcore GR 1089, FCC Part 68 and ITU-T K20  
2500 V between coil and contacts

## Typical applications

- Communications equipment  
Linecard application - analog, ISDN, xDSL  
PABX  
Voice over IP
- Office and business equipment
- Measurement and control equipment
- Consumer electronics
- Set top boxes, HiFi
- Medical equipment

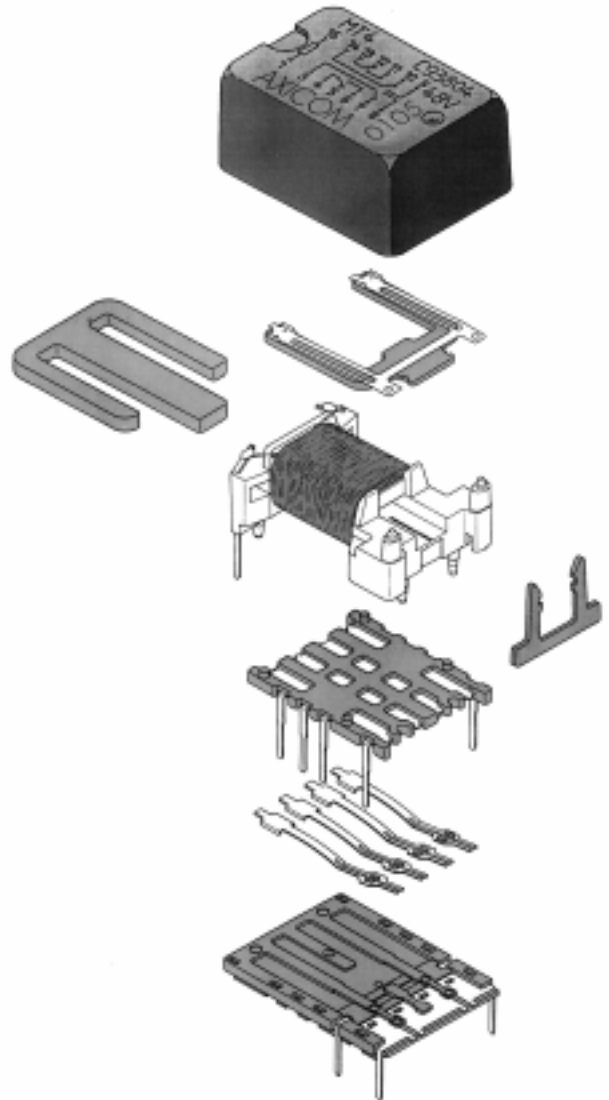

CSA-C22.2 No 14-95 File No. 176679-1079886



UL 508 File No. E 111441



CECC 16501-001

## THT Version

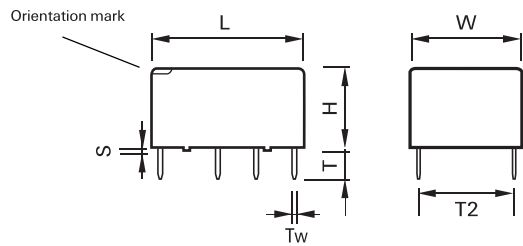

## Mounting hole layout

View onto the component side of the PCB  
(top view)

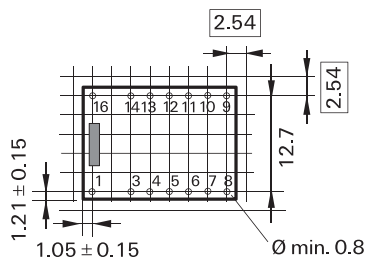

Basic grid 2.54 mm

## Terminal assignment

Relay - top view

non-latching 1 coil  
release condition

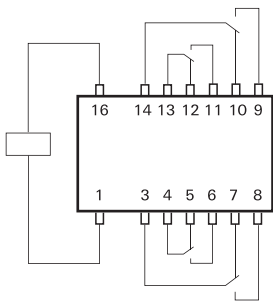

## Dimension

	THT	
	mm	inch
L	20.0 ± 0.1	0.795 ± 0.004
W	14.8 ± 0.1	0.582 ± 0.004
H	11 +0.1/-0.2	0.433 +0.004/-0.008
T	3.1 ± 0.3	0.122 ± 0.011
T1	N/A	N/A
T2	12.7 ± 0.15	0.5 ± 0.005
Tw	0.5	0.020
S	0.8	0.031

**Coil Data (values at 23°C)**

Nominal voltage $U_{nom}$	Operate voltage range		Release voltage Minimum	Nominal power consumption	Resistance	Relay Code
	Minimum voltage $U_I$	Maximum voltage $U_{II}$				
Vdc	Vdc	Vdc	Vdc	mW	$\Omega / \pm 10\%$	

non-latching  
1 coil

4.5	3.2	7.8	0.45	300	67	C 93807
5	3.6	8.65	0.50	300	83	C 93801
9	6.4	15.6	0.90	300	270	C 93805
12	8.6	20.8	1.20	300	480	C 93802
24	17.1	41.6	2.40	300	1920	C 93803
48	34.1	83.2	4.80	300	7680	C 93804

$U_I$  = Minimum voltage at 23°C after pre-energizing with nominal voltage without contact current

$U_{II}$  = Maximum continuous voltage at 23°C

The operating voltage limits  $U_I$  and  $U_{II}$  depend on the temperature according to the formula:

$$U_{I\ t_{amb}} = K_I \cdot U_{I\ 23^\circ\text{C}}$$

and

$$U_{II\ t_{amb}} = K_{II} \cdot U_{II\ 23^\circ\text{C}}$$

$t_{amb}$  = Ambient temperature

$U_{I\ t_{amb}}$  = Minimum voltage at ambient temperature,  $t_{amb}$

$U_{II\ t_{amb}}$  = Maximum voltage at ambient temperature,  $t_{amb}$

$K_I, K_{II}$  = Factors (dependent on temperature), see diagram

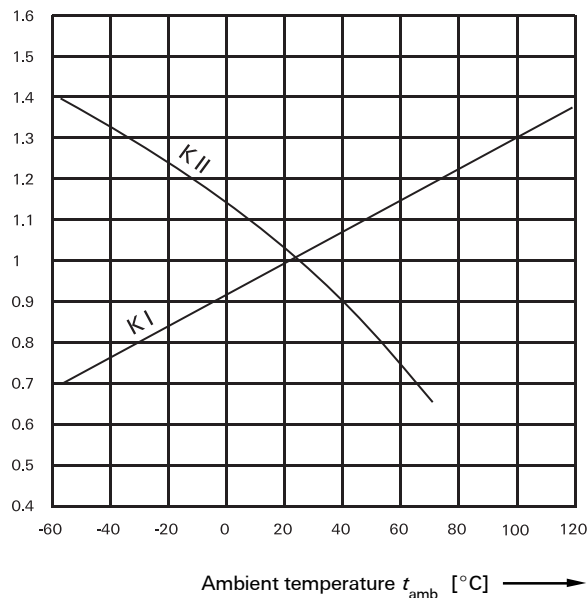

**Contact Data**

Number of contacts and type	4 changeover contacts
Contact assembly	Bifurcated contacts
Contact material	Silver-nickel, gold-covered
Limiting continuous current at max. ambient temperature	1.25 A
Maximum switching current	1.25 A
Maximum switching voltage	150 Vdc 150 Vac
Maximum switching capacity	30 W, 62.5 VA
Thermoelectric potential	< 10 $\mu$ V
Initial contact resistance / measuring condition: 10 mA / 20 mV	< 70 m $\Omega$
Electrical endurance	min. 1 x 10 <sup>7</sup> operations
Contact application 0 (<=30 mV/<= 10 mA)	min. 5 x 10 <sup>6</sup> operations
Cable load open end	min. 2.0 x 10 <sup>5</sup> operations
Resistive load 150 V / 0.2 A - 30 W	min. 2.0 x 10 <sup>5</sup> operations
24 V / 1.25 A - 30 W	
Mechanical endurance	typ. 10 <sup>9</sup> operations
UL/CSA ratings	24 Vdc / 1.25 A 125 Vac / 0.4 A

**Insulation**

Insulation resistance at 500 Vdc	> 10 <sup>9</sup> $\Omega$
Dielectric test voltage (1 min)	
between coil and contacts	1800 Vrms
between adjacent contact sets	750 Vrms
between open contacts	750 Vrms
Surge voltage resistance	
according to Bellcore TR-NWT-001089 (2 / 10 $\mu$ s)	
between coil and contacts	2500 V
between adjacent contact sets	1500 V
between open contacts	1500 V
according to FCC 68 (10 / 160 $\mu$ s) and IEC (10 / 700 $\mu$ s)	
between coil and contacts	2500 V
between adjacent contact sets	1500 V
between open contacts	1500 V

**High Frequency Data**

Capacitance	
between coil and contacts	max. 4 pF
between adjacent contact sets	max. 2 pF
between open contacts	max. 2 pF
RF Characteristics	
Isolation at 100 / 900 MHz	- 31.2 dB / - 17.2 dB
Insertion loss at 100 / 900 MHz	- 0.05 dB / - 0.91 dB
V.S.W.R. at 100 / 900 MHz	1.03 / 1.31

**General data**

Operate time at $U_{nom}$ typ. / max.	4 ms / 6 ms
Release time without diode in parallel (non-latching), typ. / max.	1 ms / 3 ms
Release time with diode in parallel (non-latching), typ. / max.	4 ms / 6 ms
Bounce time at closing contact, typ. / max.	1 ms / 5 ms
Maximum switching rate without load	50 operations/s
Ambient temperature	-55° C ... +85° C
Thermal resistance	< 105 K/W
Maximum permissible coil temperature	100° C
Vibration resistance (function)	10 G 10 to 500 Hz
Shock resistance, half sinus, 11 ms	10 G (function) 100 G (damage)
Degree of protection	immersion cleanable, IP 67
Needle flame test	application time 10 s,
Mounting position	any
Processing information	Ultrasonic cleaning is not recommended
Weight (mass)	max. 7 g
Resistance to soldering heat	260° C / 10 s

All data refers to 23° C unless otherwise specified.

**Packing**

Tube for THT version - 25 relays per tube, 500 relays per box

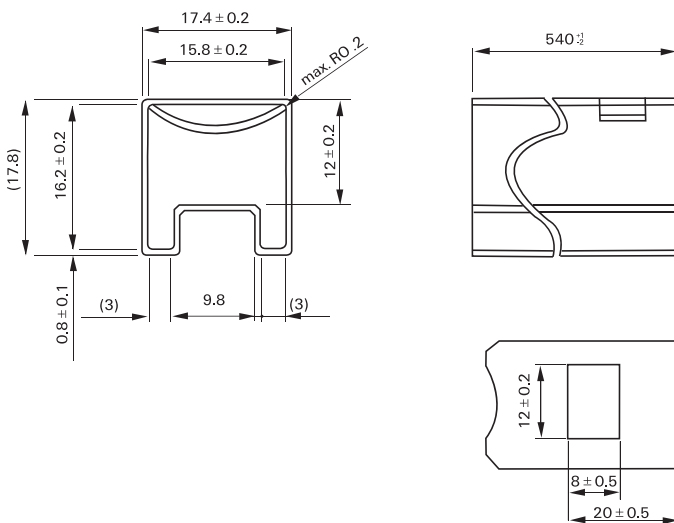

Ordering Information

Relay Code                      Tyco  
   Part Number

C93801	0-1462032-1
C93802	0-1462032-4
C93803	0-1462032-7
C93804	0-1462032-8
C93805	0-1462032-9
C93807	1-1462032-0

## IM Relays

4<sup>th</sup> generation slim line – low profile polarized 2 c/o telecom relay with bifurcated contacts, available as non latching or latching relay with 1 coil. Nominal voltage range from 1.5... 24 V, coil power consumption of 140... 200 mW, latching relays with 1 coil 100 mW. The IM relay is available as through hole and surface mount type (J-Legs and Gull Wings) and capable to switch loads up to 60 W/62,5 VA. Dielectric strength fulfills the Bellcore requirements according GR 1089 (2,5 kV – 2 / 10  $\mu$ s) and FCC part 68 (1,5 kV – 10 / 160  $\mu$ s). The IM relay is CECC/IECQ approved and certified in accordance with IEC/EN 60950 and UL1950. Dimensions approx. 10 x 6 mm board space and 5.65 mm height.

## P2 Relays

3<sup>rd</sup> generation polarized 2 c/o telecom relay with bifurcated contacts, available as non latching or latching relay with 1 or 2 coils. Nominal voltage range from 3 ... 24 V, coil power consumption 140 mW, latching relays with 1 coil 70 mW. The P2 relay is available as through hole or surface mount type and capable to switch currents up to 5 A. Dielectric strength fulfills the Bellcore requirements according GR 1089 (2,5 kV – 2 / 10  $\mu$ s) and FCC part 68 (1,5 kV – 10 / 160  $\mu$ s). Dimensions approx. 15 x 7,5 mm board space and 10 mm height.

## FX Relays

3<sup>rd</sup> generation polarized 2 c/o telecom relay with bifurcated contacts, available as non latching or latching relay with 1 coil. Nominal voltage range from 3 ... 48 V, coil power consumption of 80 ... 260 mW for the high sensitive version, 140... 300 mW for the standard version, latching relays with 1 coil 100 mW. The FX2 relay is available as through hole type and capable to switch loads up to 60 W/62,5 VA. Dielectric strength fulfills the Bellcore requirements according GR 1089 (2,5 kV – 2 / 10  $\mu$ s) and FCC part 68 (1,5 kV – 10 / 160  $\mu$ s). The FX2 is CECC/IECQ approved and certified in accordance with IEC/EN 60950 and UL1950. Dimensions approx. 15 x 7,5 mm board space and 10,7 mm height.

## FT2 / FU2 Relays

3<sup>rd</sup> generation non polarized, non latching 2 c/o telecom relay with bifurcated contacts. Nominal voltage range from 3 ... 48 V, coil power consumption 200 ... 300 mW. Most sensitive 48 V relay. Available as through hole and surface mount type. Dielectric strength fulfills the Bellcore requirements according GR 1089 (2,5 kV – 2 / 10  $\mu$ s) and FCC part 68 (1,5 kV – 10 / 160  $\mu$ s). The FT2/FU2 is CECC/IECQ approved and certified in accordance with IEC/EN 60950 and UL1950. Dimensions approx. 15 x 7,5 mm board space and 10 mm height.

## FP2 Relays

3<sup>rd</sup> generation polarized 2 c/o telecom relay with bifurcated contacts, available as non latching or latching relay with 1 or 2 coils. Nominal voltage range from 3 ... 48 V, coil power consumption of 80 ... 260 mW for the high sensitive version, 140... 300 mW for the standard version, latching relays with 1 coil 100 mW. The FP2 relay is available as through hole type and capable to switch loads up to 30 W/62,5 VA. Dielectric strength fulfills FCC part 68 (1,5 kV – 10 / 160  $\mu$ s). The FP2 is CECC/IECQ approved. Dimensions approx. 14 x 9 mm board space and 5 mm height.

## MT2 / MT4

2<sup>nd</sup> generation non polarized, non latching 2 c/o and 4 c/o telecom and signal relay with bifurcated contacts. Nominal voltage range from 4.5 ... 48 V, coil power consumption 150/200/300/400 and 550 mW, and 300 mW (MT4). Dielectric strength fulfills the

requirements according FCC part 68 (1,5 kV – 10 / 160  $\mu$ s) for both and the Bellcore requirements according GR 1089 (2,5 kV – 2 / 10  $\mu$ s) the MT4 only.

Dimensions MT2 approx. 20 x 10 mm board space and 11 mm height, MT4 approx. 20 x 15 mm board space and 11 mm height.

## D2n Relays

2<sup>nd</sup> generation non polarized 2 c/o relay for telecom and various other applications. Nominal voltage range from 3 ... 48 V, coil power consumption from 150 ... 500 mW. The D2n relay is capable to switch currents up to 3 A. Dielectric strength fulfills the requirements according FCC part 68 (1,5 kV – 10 / 160  $\mu$ s). Dimensions approx. 20 x 10 mm board space and 11,5 mm height.

## P1 Relays

Extremely sensitive, polarized 1 c/o relay with bifurcated contacts for a wide range of applications, available as non latching or latching relay with 1 or 2 coils. Nominal voltage range from 3 ... 24 V, coil power consumption 65 mW, latching relays with 1 coil 30 mW. The P1 relay is available as through hole or surface mount type and capable to switch currents up to 1 A. Dielectric strength fulfills the requirements according FCC part 68 (1,5 kV – 10 / 160  $\mu$ s). Dimensions approx. 13 x 7,6 mm board space and 7 mm height for THT or 8 mm height for SMT version.

## W11 Relays

Low cost, non polarized 1 c/o relay for various applications. Nominal voltage range from 3 ... 24 V, coil power consumption 450 mW, sensitive versions 200 mW. The W11 relay is capable to switch currents up to 3 A. Dielectric strength 1000 Vrms. Dimensions approx. 15,6 x 10,6 mm board space and 11,5 mm height.

## Reed Relays

High sensitive, non polarized relay for telecom and various other applications, available with 1 n/o, 2 n/o or 1c/o contacts. Nominal voltage range from 5 ... 24 V, coil power consumption 50...280 mW for 1 n/o and 125 ... 280 mW for 2 n/o or 1 c/o versions. Reedrelays are available in DIP or SIL housing and capable to switch currents up to 0,5 A. Integrated diode and/or electrostatic shield optional. Dielectric strength 1500 Vdc. Dimensions approx. 19,3 x 7 mm board space and 5 ... 7,5 mm height for DIP or 19,8 x 5 mm board space and 7,8 mm height for SIL version.

## Cradle Relays

Extremely reliable and mature relay family of 1<sup>st</sup> generation for various signal switching applications. Available as non polarized, polarized / latching and relay with AC coil. The benefit is the possibility of combining various contact sets from 1 up to 6 poles, single and bifurcated contacts, different contact materials with a coil voltage range from 1,5 Vdc to 220 Vac. Cradle relays are available as dust protected and hermetically sealed versions, with plug in or solder terminals and are capable to switch currents up to 5 A. Forcibly guided (linked) contact sets optional. Dielectric strength 500 Vrms. Dimensions from approx. 19 x 24 to 19x35 mm board space and 30 mm height.

## Other Relays

We offer a variety of different relay families for maintenance and replacement purposes. These relays are up to 60 years old now, such as Card Relay SN (V23030 / V23031 series), Small General Purpose Relay (V23006 series), Small Polarized Relay (V23063 ... V23067 and V23163 ... V23167 series). Accessories like sockets, hold down springs, etc. optional.



Tyco Electronics AXICOM Ltd.  
Seestrasse 295 - P.O. Box 220  
CH-8804 Au-Wädenswil / Switzerland  
Phone +41 1 782 9111  
Fax +41 1 782 9080  
E-mail: [axicom@tycoelectronics.com](mailto:axicom@tycoelectronics.com)



Tyco Electronics AMP GmbH  
Paulsternstrasse 26  
D-13629 Berlin / Germany  
Phone +49 30 386 38260  
Fax +49 30 386 38569  
E-mail: [axicom@tycoelectronics.com](mailto:axicom@tycoelectronics.com)



Tyco Electronics EC Trutnov s.r.o.  
Komenského 821  
CZ-541 01 Trutnov / Czech Republic  
E-mail: [axicom@tycoelectronics.com](mailto:axicom@tycoelectronics.com)

Tyco Electronics Corporation  
POB 3608,  
Harrisburg, PA 17105, USA  
Phone +1 800-522-6752