

**TENTATIVE**

TOSHIBA Photocoupler GaAlAs Ired + Photo IC

# TLP759(IGM)

Transistor Invertor  
 Inverter For Air Conditioner  
 Line Receiver  
 IPM Interfaces

The TOSHIBA TLP759(IGM) consists of a GaAlAs high-output light emitting diode and a high speed detector of one chip photo diode-transistor.

This unit is 8-lead DIP.

TLP759(IGM) has no internal base connection, and a faraday shield integrated on the photodetector chip provides an effective common mode noise transient immunity.

TLP759(IGM) guarantees minimum and maximum of propagation delay time, switching time dispersion, and high common mode transient immunity. Therefore TLP759(IGM) is suitable for isolation interface between IPM(intelligent power module) and control IC circuits in motor control application.

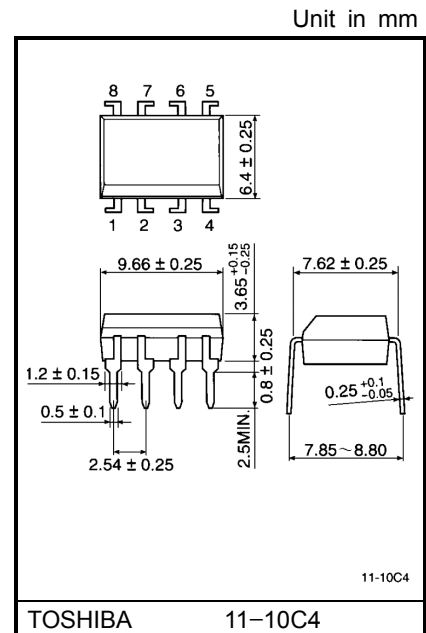

Weight: 0.54 g

- Isolation voltage: 5000V<sub>rms</sub> (min.)
- Common mode transient immunity : ±10kV / μs (min.) @VCM = 1500 V
- Switching Time : t<sub>pHL</sub>, t<sub>pLH</sub> = 0.1μs (min.) = 0.8μs (max.) @I<sub>F</sub> = 10mA, V<sub>CC</sub> = 15V, R<sub>L</sub> = 20kΩ, T<sub>a</sub> = 25°C
- Switching time dispersion: 0.7μs (max.) (| t<sub>pLH</sub> - t<sub>pHL</sub> |)
- TTL compatible
- UL recognized: UL1577, file no.E67349

## Pin Configuration(top view)

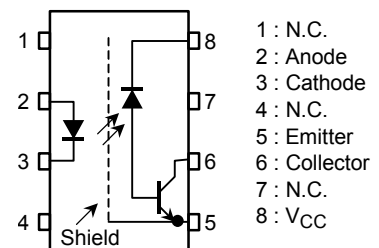

## Schematic

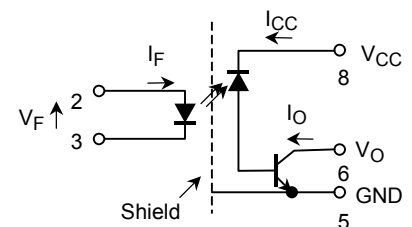

- Option (D4) type  
 VDE approved: DIN VDE0884 / 06.92,  
 Maximum operating insulation voltage: 890V<sub>PK</sub>  
 Highest permissible over voltage: 6000V<sub>PK</sub>

**(Note 1) When a VDE0884 approved type is needed, please designate the “Option (D4)”**

- Structural parameter      7.62mm pitch TLP759 (IGM)  
 Creepage distance: 7.0mm (min.)  
 Clearance: 7.0mm (min.)  
 Insulation thickness: 0.4mm (min.)

## Maximum Ratings (Ta = 25°C)

Characteristic		Symbol	Rating	Unit
LED	Forward current (Note 2)	I <sub>F</sub>	25	mA
	Pulse forward current (Note 3)	I <sub>FP</sub>	50	mA
	Peak transient forward current (Note 4)	I <sub>FPT</sub>	1	A
	Reverse voltage	V <sub>R</sub>	5	V
	Diode power dissipation (Note 5)	P <sub>D</sub>	45	mW
Detector	Output current	I <sub>O</sub>	8	mA
	Peak output current	I <sub>OP</sub>	16	mA
	Output voltage	V <sub>O</sub>	-0.5~20	V
	supply voltage	V <sub>CC</sub>	-0.5~30	V
	Output power dissipation (Note 6)	P <sub>O</sub>	100	mW
Operating temperature range		T <sub>opr</sub>	-55~100	°C
Storage temperature range		T <sub>stg</sub>	-55~125	°C
Lead solder temperature(10s) (Note 7)		T <sub>sol</sub>	260	°C
Isolation voltage(AC, 1min., R.H.≤60%, Ta=25°C) (Note 8)		BV <sub>S</sub>	2500	V <sub>rms</sub>

(Note 2): Derate 0.8mA above 70°C.

(Note 3): 50% duty cycle, 1ms pulse width.  
 Derate 1.6mA / °C above 70°C.

(Note 4): Pulse width PW ≤ 1μs, 300pps.

(Note 5): Derate 0.9mW / °C above 70°C.

(Note 6): Derate 2mW / °C above 70°C.

(Note 7): Soldering portion of lead: Up to 2mm from the body of the device.

(Note 8): Device considered a two terminal device: Pins 1, 2, 3 and 4 shorted together and pins 5, 6, 7 and 8 shorted together.

## Electrical Characteristics (Ta = 25°C)

Characteristic		Symbol	Test Condition	Min.	Typ.	Max.	Unit
LED	Forward voltage	$V_F$	$I_F = 16\text{mA}$		1.65	1.85	V
	Forward voltage temperature coefficient	$\Delta V_F / \Delta T_a$	$I_F = 16\text{mA}$	—	-2	—	mV / °C
	Reverse current	$I_R$	$V_R = 5\text{V}$	—	—	10	$\mu\text{A}$
	Capacitance between terminal	$C_T$	$V_F = 0, f = 1\text{MHz}$	—	45	—	pF
Detector	High level output current	$I_{OH(1)}$	$I_F = 0\text{mA}, V_{CC} = V_O = 5.5\text{V}$	—	3	500	nA
		$I_{OH(2)}$	$I_F = 0\text{mA}, V_{CC} = 30\text{V}$ $V_O = 20\text{V}$	—	—	5	$\mu\text{A}$
		$I_{OH}$	$I_F = 0\text{mA}, V_{CC} = 30\text{V}$ $V_O = 20\text{V}, T_a = 70^\circ\text{C}$	—	—	50	
	High level supply voltage	$I_{CCH}$	$I_F = 0\text{mA}, V_{CC} = 30\text{V}$	—	0.01	1	$\mu\text{A}$
	Supply voltage	$V_{CC}$	$I_{CC} = 0.01\text{mA}$	30	—	—	V
	Output voltage	$V_O$	$I_O = 0.5\text{mA}$	20	—	—	V

## Coupled Electrical Characteristics (Ta = 25°C)

Characteristic	Symbol	Test Condition	Min.	Typ.	Max.	Unit
Current transfer ratio	$I_O / I_F$	$I_F = 10\text{mA}, V_{CC} = 4.5\text{V}$ $V_O = 0.4\text{V}$	25	35	75	%
		$I_F = 16\text{mA}, V_{CC} = 4.5\text{V}$ $V_O = 0.4\text{V}, T_a = -25\sim 100^\circ\text{C}$	15	—	—	
Low level output voltage	$V_{OL}$	$I_F = 16\text{mA}, V_{CC} = 4.5\text{V}$ $I_O = 2.4\text{mA}$	—	—	0.4	V

## Isolation Characteristics (Ta = 25°C)

Characteristic	Symbol	Test Condition	Min.	Typ.	Max.	Unit
Capacitance input to output	$C_S$	$V = 0, f = 1\text{MHz}$ (Note 8)	—	0.8	—	pF
Isolation resistance	$R_S$	R.H. $\leq 60\%$ , $V_S = 500\text{V}$ (Note 8)	$1 \times 10^{12}$	$10^{14}$	—	$\Omega$
Isolation voltage	$BV_S$	AC, 1 minute	5000	—	—	$V_{rms}$
		AC, 1 second, in oil	—	10000	—	Vdc
		DC, 1 minute, in oil	—	10000	—	

**Switching Characteristics (Ta = 25°C, VCC = 15V)**

Characteristic	Symbol	Test Circuit	Test Condition	Min.	Typ.	Max.	Unit
Propagation delay time (H→L)	$t_{pHL}$	1	$I_F = 10\text{mA}, R_L = 20\text{k}\Omega$	0.1	0.45	0.8	$\mu\text{s}$
Propagation delay time (L→H)	$t_{pLH}$		$I_F = 10\text{mA}, R_L = 20\text{k}\Omega$ $T_a = 0\sim 85^\circ\text{C}$	0.1	0.45	0.9	
			$I_F = 10\text{mA}, R_L = 20\text{k}\Omega$ $T_a = -25\sim 100^\circ\text{C}$	0.1	0.45	1.0	
Switching time dispersion between on and off	$ t_{pLH} - t_{pHL} $	1	$I_F = 10\text{mA}, R_L = 20\text{k}\Omega$	—	0.15	0.7	$\mu\text{s}$
			$I_F = 10\text{mA}, R_L = 20\text{k}\Omega$ $T_a = 0\sim 85^\circ\text{C}$	—	0.25	0.8	
			$I_F = 10\text{mA}, R_L = 20\text{k}\Omega$ $T_a = -25\sim 100^\circ\text{C}$	—	0.25	0.9	
Common mode transient immunity at logic high output (Note 9)	$CM_H$	2	$I_F = 0\text{mA}$ $V_{CM} = 1500\text{V}_{p-p}$ $R_L = 20\text{k}\Omega$	10000	15000	—	$\text{V} / \mu\text{s}$
Common mode transient immunity at logic low output (Note 9)	$CM_L$		$I_F = 10\text{mA}$ $V_{CM} = 1500\text{V}_{p-p}$ $R_L = 20\text{k}\Omega$	-10000	-15000	—	$\text{V} / \mu\text{s}$

(Note 9):  $CM_L$  is the maximum rate of fall of the common mode voltage that can be sustained with the output voltage in the logic low state ( $V_O < 1\text{V}$ ).  
 $CM_H$  is the maximum rate of rise of the common mode voltage that can be sustained with the output voltage in the logic high state ( $V_O < 4\text{V}$ ).

(Note 10): Maximum electrostatic discharge voltage for any pins:  $100\text{V}(C = 200\text{pF}, R = 0)$ .

**Test Circuit 1: Switching Time Test Circuit**

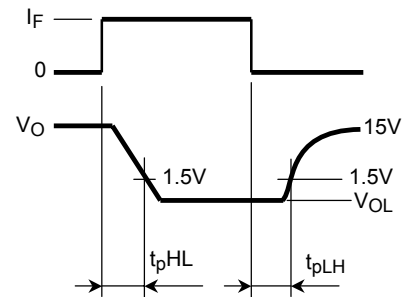
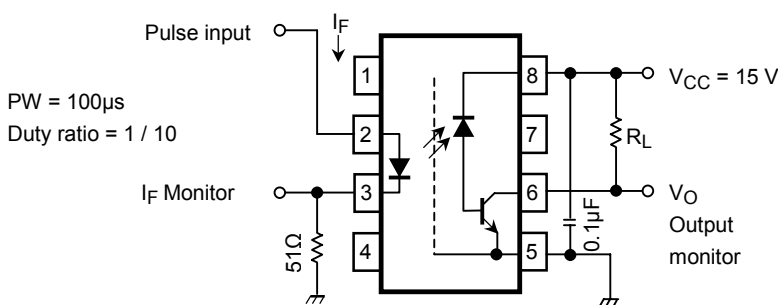

**Test Circuit 2: Common Mode Noise Immunity Test Circuit**

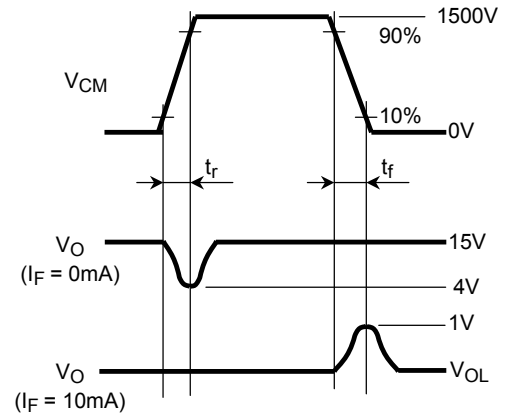
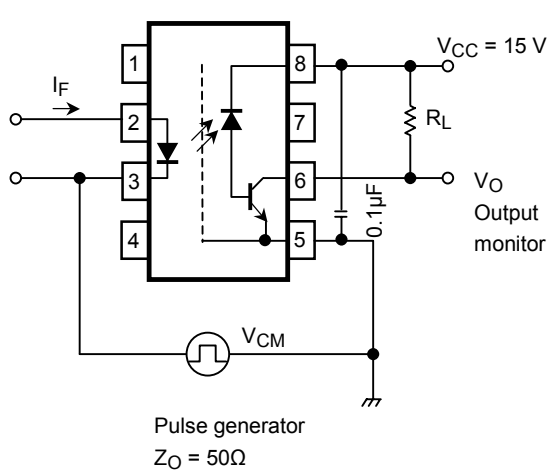

$$CM_{IH} = \frac{1200(V)}{t_r(\mu s)}, CM_{IL} = \frac{1200(V)}{t_f(\mu s)}$$

**RESTRICTIONS ON PRODUCT USE**

000707EAA

- TOSHIBA is continually working to improve the quality and reliability of its products. Nevertheless, semiconductor devices in general can malfunction or fail due to their inherent electrical sensitivity and vulnerability to physical stress. It is the responsibility of the buyer, when utilizing TOSHIBA products, to comply with the standards of safety in making a safe design for the entire system, and to avoid situations in which a malfunction or failure of such TOSHIBA products could cause loss of human life, bodily injury or damage to property.  
In developing your designs, please ensure that TOSHIBA products are used within specified operating ranges as set forth in the most recent TOSHIBA products specifications. Also, please keep in mind the precautions and conditions set forth in the "Handling Guide for Semiconductor Devices," or "TOSHIBA Semiconductor Reliability Handbook" etc..
- The TOSHIBA products listed in this document are intended for usage in general electronics applications (computer, personal equipment, office equipment, measuring equipment, industrial robotics, domestic appliances, etc.). These TOSHIBA products are neither intended nor warranted for usage in equipment that requires extraordinarily high quality and/or reliability or a malfunction or failure of which may cause loss of human life or bodily injury ("Unintended Usage"). Unintended Usage include atomic energy control instruments, airplane or spaceship instruments, transportation instruments, traffic signal instruments, combustion control instruments, medical instruments, all types of safety devices, etc.. Unintended Usage of TOSHIBA products listed in this document shall be made at the customer's own risk.
- The information contained herein is presented only as a guide for the applications of our products. No responsibility is assumed by TOSHIBA CORPORATION for any infringements of intellectual property or other rights of the third parties which may result from its use. No license is granted by implication or otherwise under any intellectual property or other rights of TOSHIBA CORPORATION or others.
- The information contained herein is subject to change without notice.