

TOSHIBA PHOTOCOUPLER GaAs IRED & PHOTO-TRANSISTOR

# TLP283,TLP283-4

## PROGRAMMABLE CONTROLLERS

AC adapters for PDAs/ on-board power supplies

I/O interface boards

TLP283 and TLP283-4 is a very small and thin coupler,suitable for surface mount assembly in applications such as on-board power supplies,programmable controllers.

TLP283 and TLP283-4 consist of photo transistor,optically coupled to a gallium arsenide infrared emitting diode.

- Collector-Emitter Voltage : 100 V (MIN)
- Current Transfer Ratio : 100% (MIN)@IF=1mA
- 1 Pulse delay time(Note 1) : 100us(MAX)@IF=1mA,RL=10kΩ
- Isolation Voltage : 2500 Vrms (MIN)
- UL Recognized : UL1577 , File No. E67349

Note 1 : 1 Pulse delay time = tON+tOFF

Unit in mm

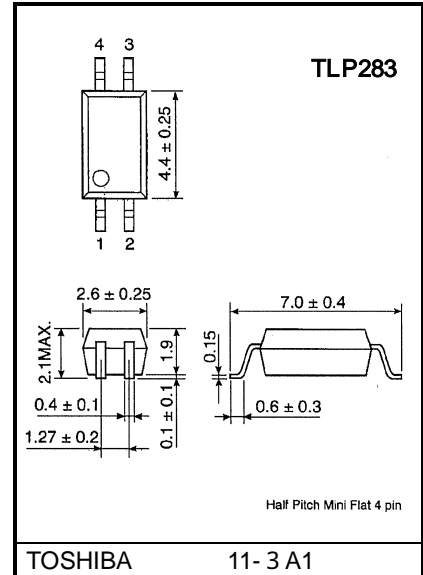

Weight: 0.05 g (typ.)

## PIN CONFIGURATION(Top view)

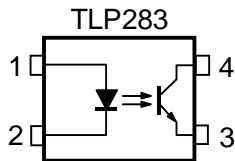

- 1: ANODE
- 2: CATHODE
- 3: EMITTER
- 4: COLLECTOR

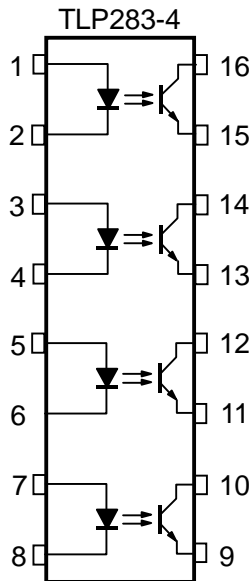

- 1,3,5,7 : ANODE
- 2,4,6,8 : CATHODE
- 9,11,13,15 : EMITTER
- 10,12,14,16 : COLLECTOR

Unit in mm

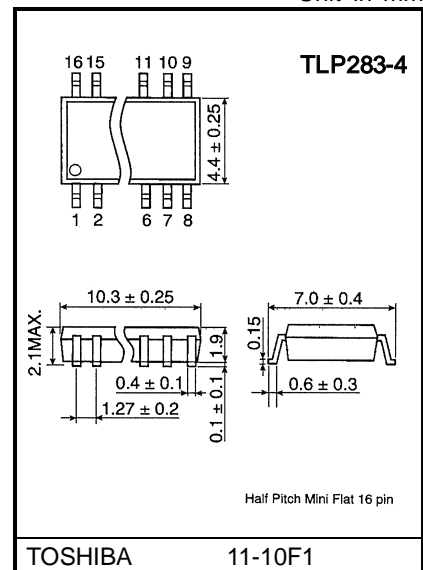

Weight: 0.19 g (typ.)

## MAXIMUM RATINGS (Ta = 25 )

CHARACTERISTIC		SYMBOL	RATING		UNIT
			TLP283	TLP283-4	
LED	Forward Current	$I_F$	50		mA
	Forward Current Derating	$\Delta I_F / ^\circ\text{C}$	-0.7 (Ta $\geq$ 53°C)	-0.5 (Ta $\geq$ 25°C)	mA /°C
	Pulse Forward Current	$I_{FP}$	1		A
	Reverse Voltage	$V_R$	5		V
	Junction Temperature	$T_j$	125		°C
DETECTOR	Collector-Emitter Voltage	$V_{CEO}$	100		V
	Emitter-Collector Voltage	$V_{ECO}$	7		V
	Collector Current	$I_C$	50		mA
	Collector Power Dissipation (1 Circuit)	$P_C$	150	100	mW
	Collector Power Dissipation Derating (Ta $\geq$ 25°C) (1 Circuit)	$\Delta P_C / ^\circ\text{C}$	-1.5	-1.0	mW /°C
	Junction Temperature	$T_j$	125		°C
Operating Temperature Range		$T_{opr}$	-55~100		°C
Storage Temperature Range		$T_{stg}$	-55~125		°C
Lead Soldering Temperature		$T_{sol}$	260 (10s)		°C
Total Package Power Dissipation (1 Circuit)		$P_T$	200	170	mW
Total Package Power Dissipation Derating (Ta $\geq$ 25°C) (1 Circuit)		$\Delta P_T / ^\circ\text{C}$	-2.0	-1.7	mW /°C
Isolation Voltage (Note2)		$BV_S$	2500(AC, 1min, R.H. $\leq$ 60%)		Vrms

(Note2) Device considered a two terminal device : LED side pins shorted together and DETECTOR side pins shorted together.

## INDIVIDUAL ELECTRICAL CHARACTERISTICS (Ta = 25 )

CHARACTERISTIC		SYMBOL	TEST CONDITION	MIN.	TYP.	MAX.	UNIT
LED	Forward Voltage	$V_F$	$I_F = 10 \text{ mA}$	1.0	1.15	1.3	V
	Reverse Current	$I_R$	$V_R = 5 \text{ V}$	—	—	10	$\mu\text{A}$
	Capacitance	$C_T$	$V = 0, f = 1 \text{ MHz}$	—	30	—	pF
DETECTOR	Collector-Emitter Breakdown Voltage	$V_{(BR) CEO}$	$I_C = 0.5 \text{ mA}$	100	—	—	V
	Emitter-Collector Breakdown Voltage	$V_{(BR) ECO}$	$I_E = 0.1 \text{ mA}$	7	—	—	V
	Collector Dark Current (Note3)	$I_{CEO}$	$V_{CE} = 48 \text{ V},$ Ambient Light Below (100 lx)	—	0.01 (2)	0.1 (10)	$\mu\text{A}$
			$V_{CE} = 48 \text{ V}, T_a = 85^\circ\text{C}$ Ambient Light Below (100 lx)	—	2 (4)	50 (50)	$\mu\text{A}$
Capacitance (Collector to Emitter)	$C_{CE}$		$V = 0, f = 1 \text{ MHz}$	—	10	—	pF

(Note3) Because of the construction, leak current might be increased by ambient light. Please use photocoupler with less ambient light.

**COUPLED ELECTRICAL CHARACTERISTICS (Ta = 25 )**

CHARACTERISTIC	SYMBOL	TEST CONDITION	MIN.	TYP.	MAX.	UNIT
Current Transfer Ratio	$I_C / I_F$	$I_F = 1 \text{ mA}, V_{CE} = 5 \text{ V}$	100	—	400	%
Saturated CTR	$I_C / I_F (\text{sat})$	$I_F = 1 \text{ mA}, V_{CE} = 0.4 \text{ V}$	50	—	—	%
Collector-Emitter Saturation Voltage	$V_{CE} (\text{sat})$	$I_C = 0.2 \text{ mA}, I_F = 1 \text{ mA}$	—	0.2	0.4	V
Off-State Collector Current	$I_C (\text{off})$	$V_F = 0.7 \text{ V}, V_{CE} = 48 \text{ V}$	—	—	10	$\mu\text{A}$

**ISOLATION CHARACTERISTICS (Ta = 25 )**

CHARACTERISTIC	SYMBOL	TEST CONDITION	MIN.	TYP.	MAX.	UNIT
Capacitance (Input to Output)	$C_S$	$V_S = 0 \text{ V}, f = 1 \text{ MHz}$	—	0.8	—	pF
Isolation Resistance	$R_S$	$V_S = 500 \text{ V}, R.H. \leq 60\%$	$5 \times 10^{10}$	$10^{14}$	—	$\Omega$
Isolation Voltage	$BV_S$	AC , 1 minute	2500	—	—	Vrms
		AC , 1 second, in OIL	—	5000	—	
		DC , 1 minute, in OIL	—	5000	—	Vdc

**SWITCHING CHARACTERISTICS (Ta = 25 )**

CHARACTERISTIC	SYMBOL	TEST CONDITION	MIN.	TYP.	MAX.	UNIT
Turn-On Time	$t_{ON}$	$V_{CC} = 5 \text{ V}, I_F = 1 \text{ mA}$ $R_L = 10 \text{ k}\Omega$	—	7.5	20	$\mu\text{s}$
Turn-Off Time	$t_{OFF}$		—	70	90	
1 Pulse delay time	$t_{ON} + t_{OFF}$		—	80	100	

(Fig.1) SWITCHING TIME TEST CIRCUIT

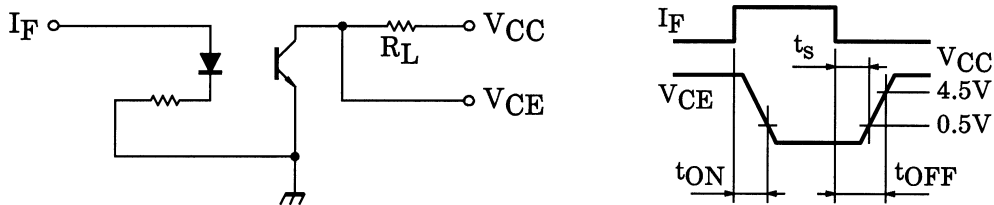

**RESTRICTIONS ON PRODUCT USE**

030619EBC

- The information contained herein is subject to change without notice.
- The information contained herein is presented only as a guide for the applications of our products. No responsibility is assumed by TOSHIBA for any infringements of patents or other rights of the third parties which may result from its use. No license is granted by implication or otherwise under any patent or patent rights of TOSHIBA or others.
- TOSHIBA is continually working to improve the quality and reliability of its products. Nevertheless, semiconductor devices in general can malfunction or fail due to their inherent electrical sensitivity and vulnerability to physical stress. It is the responsibility of the buyer, when utilizing TOSHIBA products, to comply with the standards of safety in making a safe design for the entire system, and to avoid situations in which a malfunction or failure of such TOSHIBA products could cause loss of human life, bodily injury or damage to property.  
In developing your designs, please ensure that TOSHIBA products are used within specified operating ranges as set forth in the most recent TOSHIBA products specifications. Also, please keep in mind the precautions and conditions set forth in the "Handling Guide for Semiconductor Devices," or "TOSHIBA Semiconductor Reliability Handbook" etc..
- The TOSHIBA products listed in this document are intended for usage in general electronics applications (computer, personal equipment, office equipment, measuring equipment, industrial robotics, domestic appliances, etc.). These TOSHIBA products are neither intended nor warranted for usage in equipment that requires extraordinarily high quality and/or reliability or a malfunction or failure of which may cause loss of human life or bodily injury ("Unintended Usage"). Unintended Usage include atomic energy control instruments, airplane or spaceship instruments, transportation instruments, traffic signal instruments, combustion control instruments, medical instruments, all types of safety devices, etc.. Unintended Usage of TOSHIBA products listed in this document shall be made at the customer's own risk.
- The products described in this document are subject to the foreign exchange and foreign trade laws.
- TOSHIBA products should not be embedded to the downstream products which are prohibited to be produced and sold, under any law and regulations.
- GaAs(Gallium Arsenide) is used in this product. The dust or vapor is harmful to the human body. Do not break, cut, crush or dissolve chemically.