

Preliminary

TLP2066

FA (Factory Automation)
 High Speed Interface
 3.3V Supply Voltage

The Toshiba TLP2066 consists of a GaAlAs light-emitting diode and an integrated high-gain, high-speed photodetector. TLP2066 operates with 3.3 V supply voltage. Toshiba provides the TLP116 for supply voltage 5V type.

- Inverter logic (totempole output)
- Package type : MFSOP6
- Guaranteed performance over temperature : -40~100°C
- Power supply voltage : 3.0~3.6V
- Input thresholds current: $I_{FHL}=5\text{mA}$ (Max.)
- Propagation delay time (tpHL/tpLH): 60ns (Max.)
- Switching speed : 20MBd(TYP.)(NRZ)
- Common mode transient immunity : 15kV/us
- Isolation voltage : 3750Vrms
- UL recognition: UL1577 under application

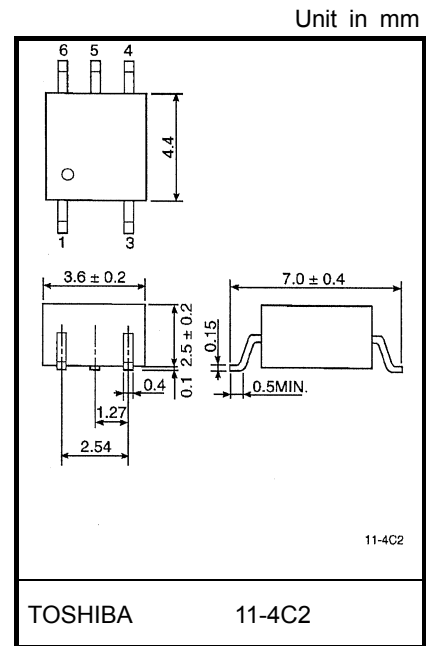

Weight: 0.09 g(Typ.)

Pin Configuration (Top View)

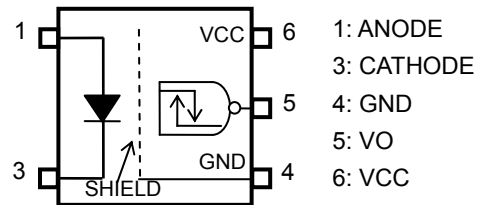

Truth Table

Input	LED	Tr1	Tr2	Output
H	ON	OFF	ON	L
L	OFF	ON	OFF	H

Schematic

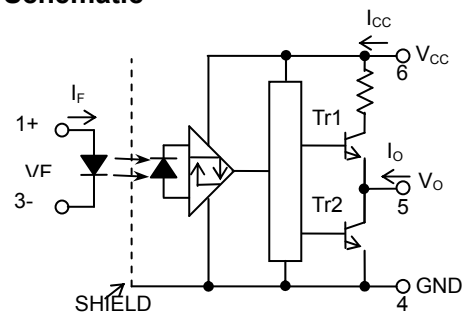

0.1uF bypass capacitor must be connected between pins 6 and 4

Absolute Maximum Ratings (Ta=25°C)

Characteristic		Symbol	Rating	Unit
LED	Forward current	I _F	25	mA
	Forward current derating (Ta≥85°C)	ΔI _F /ΔTa	-0.7	mA/°C
	Peak transient forward current (Note1)	I _{FPT}	1	A
	Reverse voltage	V _R	6	V
DETECTOR	Output current	I _O	10	mA
	Output voltage	V _O	6	V
	Supply voltage	V _{CC}	6	V
	Output power dissipation	P _O	40	mW
Operating temperature range		T _{opr}	-40~100	°C
Storage temperature range		T _{stg}	-55~125	°C
Lead solder temperature(10s)		T _{sol}	260	°C
Isolation voltage (AC,1min.,R.H.≤60%,Ta=25°C) (Note2)		BVs	3750	Vrms

Note: Using continuously under heavy loads (e.g. the application of high temperature/current/voltage and the significant change in temperature, etc.) may cause this product to decrease in the reliability significantly even if the operating conditions (i.e. operating temperature/current/voltage, etc.) are within the absolute maximum ratings.

Please design the appropriate reliability upon reviewing the Toshiba Semiconductor Reliability Handbook (“Handling Precautions”/“Derating Concept and Methods”) and individual reliability data (i.e. reliability test report and estimated failure rate, etc).

Note1: Pulse width PW≤1us, 300pps.

Note2: This device is regarded as a two terminal device: pins 1 and 3 are shorted together, as are pins 4, 5 and 6.

Recommended Operating Conditions

Characteristic	Symbol	Min	Typ.	Max	Unit
Input current , ON	I _{F(ON)}	8	—	18	mA
Input voltage , OFF	V _{F(OFF)}	0	—	0.8	V
Supply voltage(*) (Note3)	V _{CC}	3.0	3.3	3.6	V

(*) This item denotes operating ranges, not meaning of recommended operating conditions.

Note: Recommended operating conditions are given as a design guideline to obtain expected performance of the device. Additionally, each item is an independent guideline respectively. In developing designs using this product, please confirm specified characteristics shown in this document.

Note3: The detector of this product requires a power supply voltage (VCC) of 3.0 V higher for stable operation. If the VCC is lower than this value, an ICCH may increase, or an output may be unstable. Be sure to use the product after checking the supply current, and the operation of a power-on/-off.

Note 4: A ceramic capacitor(0.1 μF) should be connected from pin 6 to pin 4 to stabilize the operation of the high gain linear amplifier. Failure to provide the bypass may impair the switching property. The total lead length between capacitor and coupler should not exceed 1 cm.

Electrical Characteristics

(Unless otherwise specified, Ta=-40~100°C, VCC=3.0~3.6 V)

Characteristic	Symbol	Test Circuit	Conditions	Min.	Typ.	Max.	Unit
Input forward voltage	V _F	—	I _F =10mA, Ta=25°C	1.45	1.6	1.85	V
Temperature coefficient of forward voltage	ΔV _F /ΔTa	—	I _F =10mA	—	2	—	mV/°C
Input reverse current	I _R	—	V _R =6V, Ta=25°C	—	—	10	μA
Input capacitance	C _T	—	V=0, f=1MHz, Ta=25°C	—	60	—	pF
Logic low output voltage	V _{OL}	1	I _{OL} =1.6mA, I _F =12mA	—	—	0.6	V
Logic high output voltage	V _{OH}	2	I _{OH} =-0.02mA, V _F =1.05V	2.0	—	—	V
Logic low supply current	I _{CCL}	3	I _F =12mA, VCC=3.3V	—	—	5.0	mA
Logic high supply current	I _{CCH}	4	V _F =0V, VCC=3.3V (Note 3)	—	—	5.0	mA
Supply voltage	VCC	—	—	3.0	—	3.6	V
Input current logic low output	I _{FHL}	—	I _O =1.6mA, V _O <0.6V	—	—	5	mA
Input voltage logic high output	V _{FLH}	—	I _O =-0.02mA, V _O >2.0V	0.8	—	—	V

*All typical values are at Ta=25°C, VCC=3.3V, I_F (ON) =12mA unless otherwise specified

Isolation Characteristics (Ta = 25°C)

Characteristic	Symbol	Test Conditions	Min.	Typ.	Max.	Unit
Capacitance input to output	C _S	V _s = 0, f = 1MHz (Note 2)	—	0.8	—	pF
Isolation resistance	R _S	R.H. ≤ 60%, V _S = 500V (Note 2)	1×10 ¹²	10 ¹⁴	—	Ω
Isolation voltage	BV _S	AC, 1 minute	3750	—	—	V _{rms}
		AC, 1 second, in oil	—	10000	—	
		DC, 1 minute, in oil	—	10000	—	V _{dc}

Note 4: A ceramic capacitor(0.1 μF) should be connected from pin 6 to pin 4 to stabilize the operation of the high gain linear amplifier. Failure to provide the bypass may impair the switching property.
The total lead length between capacitor and coupler should not exceed 1 cm.

Switching Characteristics

(Unless otherwise specified, $T_a = -40 \sim 100^\circ\text{C}$, $V_{CC} = 3.3\text{V}$)

Characteristic	Symbol	Test Circuit	Conditions	Min.	Typ.	Max.	Unit		
Propagation delay time to logic high output	t_{pHL}	5	$I_F = 0 \rightarrow 12\text{mA}$	$R_{IN} = 100\Omega$ $C_L = 15\text{pF}$ (Note 5)	—	—	60	ns	
Propagation delay time to logic low output	t_{pLH}		$I_F = 12 \rightarrow 0\text{mA}$		—	—	60	ns	
Propagation delay time to logic high output	t_{pHL}	6	$V_{IN} = 0 \rightarrow 3.3\text{V}$ ($I_F = 0 \rightarrow 8\text{mA}$)	$R_{IN} = 220\Omega$ $C_{IN} = 47\text{pF}$ $C_L = 15\text{pF}$ (Note 5)	—	—	60	ns	
Propagation delay time to logic low output	t_{pLH}		$V_{IN} = 3.3 \rightarrow 0\text{V}$ ($I_F = 8 \rightarrow 0\text{mA}$)		—	—	60	ns	
Switching time dispersion between ON and OFF	$ t_{pHL} - t_{pLH} $	5	$I_F = 12\text{mA}$, $R_{IN} = 100\Omega$, $C_L = 15\text{pF}$ (Note 5)		—	—	30	ns	
Output fall time (90-10%)	t_f		$I_F = 0 \rightarrow 12\text{mA}$	$R_{IN} = 100\Omega$ $C_L = 15\text{pF}$ (Note 5)		—	4	—	ns
Output rise time (10-90%)	t_r		$I_F = 12 \rightarrow 0\text{mA}$			—	5	—	ns
Common mode transient immunity at high Level output	CM_H	7	$V_{CM} = 1000\text{Vp-p}$, $I_F = 0\text{mA}$, $V_o(\text{Min}) = 2\text{V}$, $T_a = 25^\circ\text{C}$		15000	—	—	$\text{V}/\mu\text{s}$	
Common mode transient immunity at low level output	CM_L		$V_{CM} = 1000\text{Vp-p}$, $I_F = 12\text{mA}$, $V_o(\text{Max}) = 0.8\text{V}$, $T_a = 25^\circ\text{C}$		-15000	—	—	$\text{V}/\mu\text{s}$	

*All typical values are at $T_a = 25^\circ\text{C}$

Note 5: C_L is approximately 15pF which includes probe and Jig/stray wiring capacitance.

TEST CIRCUIT 1: VOL

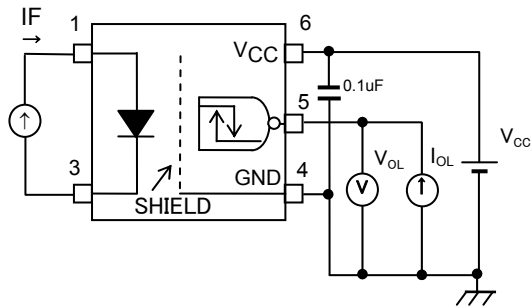

TEST CIRCUIT 2: VOH

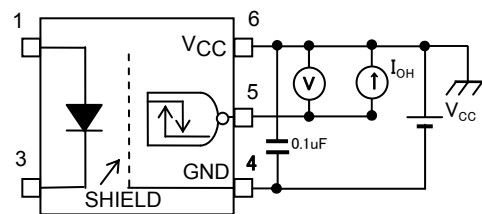

TEST CIRCUIT 3: ICCL

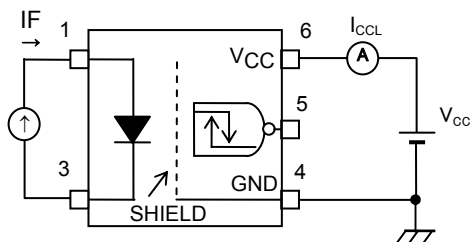

TEST CIRCUIT 4: ICCH

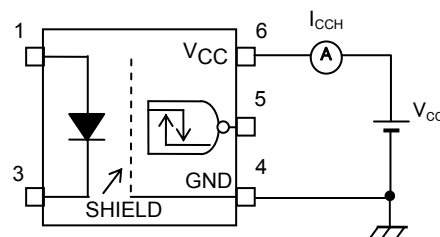

TEST CIRCUIT 5: tpHL , tpLH

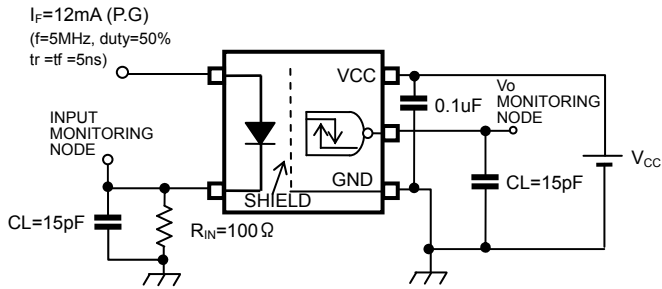

CL is capacitance of the probe and JIG.
(P.G): Pulse Generator

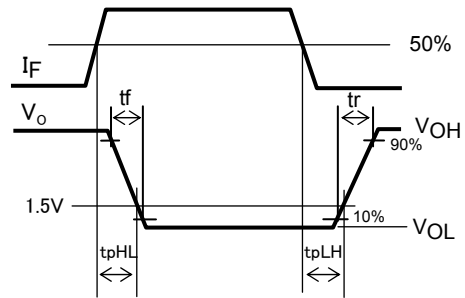

TEST CIRCUIT 6: tpHL, tpLH

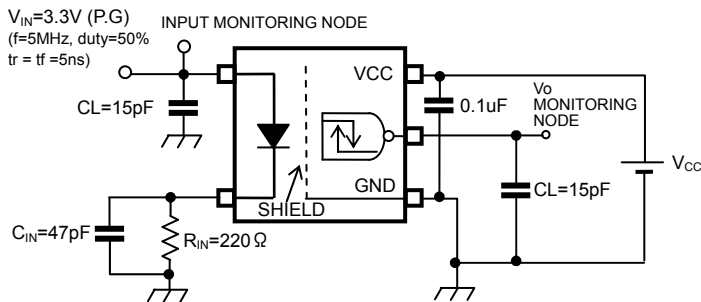

CL is capacitance of the probe and JIG.
(P.G): Pulse Generator

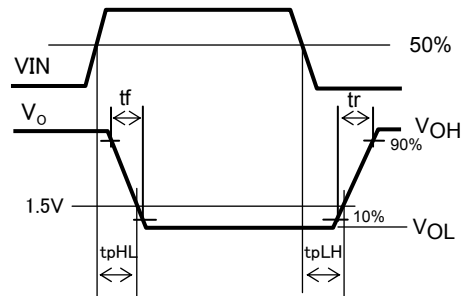

TEST CIRCUIT 7: Common-Mode Transient Immunity Test Circuit

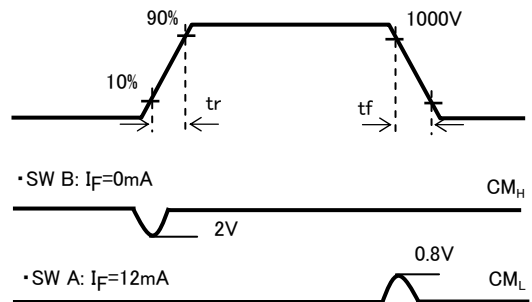
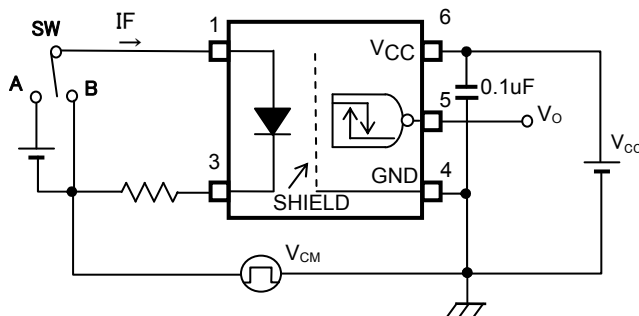

$$CM_H = \frac{800(V)}{tr(\mu s)} \quad CM_L = \frac{800(V)}{tf(\mu s)}$$

RESTRICTIONS ON PRODUCT USE

- Toshiba Corporation, and its subsidiaries and affiliates (collectively "TOSHIBA"), reserve the right to make changes to the information in this document, and related hardware, software and systems (collectively "Product") without notice.
- This document and any information herein may not be reproduced without prior written permission from TOSHIBA. Even with TOSHIBA's written permission, reproduction is permissible only if reproduction is without alteration/omission.
- Though TOSHIBA works continually to improve Product's quality and reliability, Product can malfunction or fail. Customers are responsible for complying with safety standards and for providing adequate designs and safeguards for their hardware, software and systems which minimize risk and avoid situations in which a malfunction or failure of Product could cause loss of human life, bodily injury or damage to property, including data loss or corruption. Before creating and producing designs and using, customers must also refer to and comply with (a) the latest versions of all relevant TOSHIBA information, including without limitation, this document, the specifications, the data sheets and application notes for Product and the precautions and conditions set forth in the "TOSHIBA Semiconductor Reliability Handbook" and (b) the instructions for the application that Product will be used with or for. Customers are solely responsible for all aspects of their own product design or applications, including but not limited to (a) determining the appropriateness of the use of this Product in such design or applications; (b) evaluating and determining the applicability of any information contained in this document, or in charts, diagrams, programs, algorithms, sample application circuits, or any other referenced documents; and (c) validating all operating parameters for such designs and applications. **TOSHIBA ASSUMES NO LIABILITY FOR CUSTOMERS' PRODUCT DESIGN OR APPLICATIONS.**
- Product is intended for use in general electronics applications (e.g., computers, personal equipment, office equipment, measuring equipment, industrial robots and home electronics appliances) or for specific applications as expressly stated in this document. Product is neither intended nor warranted for use in equipment or systems that require extraordinarily high levels of quality and/or reliability and/or a malfunction or failure of which may cause loss of human life, bodily injury, serious property damage or serious public impact ("Unintended Use"). Unintended Use includes, without limitation, equipment used in nuclear facilities, equipment used in the aerospace industry, medical equipment, equipment used for automobiles, trains, ships and other transportation, traffic signaling equipment, equipment used to control combustions or explosions, safety devices, elevators and escalators, devices related to electric power, and equipment used in finance-related fields. Do not use Product for Unintended Use unless specifically permitted in this document.
- Do not disassemble, analyze, reverse-engineer, alter, modify, translate or copy Product, whether in whole or in part.
- Product shall not be used for or incorporated into any products or systems whose manufacture, use, or sale is prohibited under any applicable laws or regulations.
- The information contained herein is presented only as guidance for Product use. No responsibility is assumed by TOSHIBA for any infringement of patents or any other intellectual property rights of third parties that may result from the use of Product. No license to any intellectual property right is granted by this document, whether express or implied, by estoppel or otherwise.
- **ABSENT A WRITTEN SIGNED AGREEMENT, EXCEPT AS PROVIDED IN THE RELEVANT TERMS AND CONDITIONS OF SALE FOR PRODUCT, AND TO THE MAXIMUM EXTENT ALLOWABLE BY LAW, TOSHIBA (1) ASSUMES NO LIABILITY WHATSOEVER, INCLUDING WITHOUT LIMITATION, INDIRECT, CONSEQUENTIAL, SPECIAL, OR INCIDENTAL DAMAGES OR LOSS, INCLUDING WITHOUT LIMITATION, LOSS OF PROFITS, LOSS OF OPPORTUNITIES, BUSINESS INTERRUPTION AND LOSS OF DATA, AND (2) DISCLAIMS ANY AND ALL EXPRESS OR IMPLIED WARRANTIES AND CONDITIONS RELATED TO SALE, USE OF PRODUCT, OR INFORMATION, INCLUDING WARRANTIES OR CONDITIONS OF MERCHANTABILITY, FITNESS FOR A PARTICULAR PURPOSE, ACCURACY OF INFORMATION, OR NONINFRINGEMENT.**
- GaAs (Gallium Arsenide) is used in Product. GaAs is harmful to humans if consumed or absorbed, whether in the form of dust or vapor. Handle with care and do not break, cut, crush, grind, dissolve chemically or otherwise expose GaAs in Product.
- Do not use or otherwise make available Product or related software or technology for any military purposes, including without limitation, for the design, development, use, stockpiling or manufacturing of nuclear, chemical, or biological weapons or missile technology products (mass destruction weapons). Product and related software and technology may be controlled under the Japanese Foreign Exchange and Foreign Trade Law and the U.S. Export Administration Regulations. Export and re-export of Product or related software or technology are strictly prohibited except in compliance with all applicable export laws and regulations.
- Please contact your TOSHIBA sales representative for details as to environmental matters such as the RoHS compatibility of Product. Please use Product in compliance with all applicable laws and regulations that regulate the inclusion or use of controlled substances, including without limitation, the EU RoHS Directive. TOSHIBA assumes no liability for damages or losses occurring as a result of noncompliance with applicable laws and regulations.