

Current Mode PWM Controller

FEATURES

- Optimized For Off-line And DC To DC Converters
- Low Start Up Current (<1mA)
- Automatic Feed Forward Compensation
- Pulse-by-pulse Current Limiting
- Enhanced Load Response Characteristics
- Under-voltage Lockout With Hysteresis
- Double Pulse Suppression
- High Current Totem Pole Output
- Internally Trimmed Bandgap Reference
- 500khz Operation
- Low Ro Error Amp

DESCRIPTION

The UC1842/3/4/5 family of control ICs provides the necessary features to implement off-line or DC to DC fixed frequency current mode control schemes with a minimal external parts count. Internally implemented circuits include under-voltage lockout featuring start up current less than 1mA, a precision reference trimmed for accuracy at the error amp input, logic to insure latched operation, a PWM comparator which also provides current limit control, and a totem pole output stage designed to source or sink high peak current. The output stage, suitable for driving N Channel MOSFETs, is low in the off state.

Differences between members of this family are the under-voltage lockout thresholds and maximum duty cycle ranges. The UC1842 and UC1844 have UVLO thresholds of 16V (on) and 10V (off), ideally suited to off-line applications. The corresponding thresholds for the UC1843 and UC1845 are 8.4V and 7.6V. The UC1842 and UC1843 can operate to duty cycles approaching 100%. A range of zero to 50% is obtained by the UC1844 and UC1845 by the addition of an internal toggle flip flop which blanks the output off every other clock cycle.

BLOCK DIAGRAM

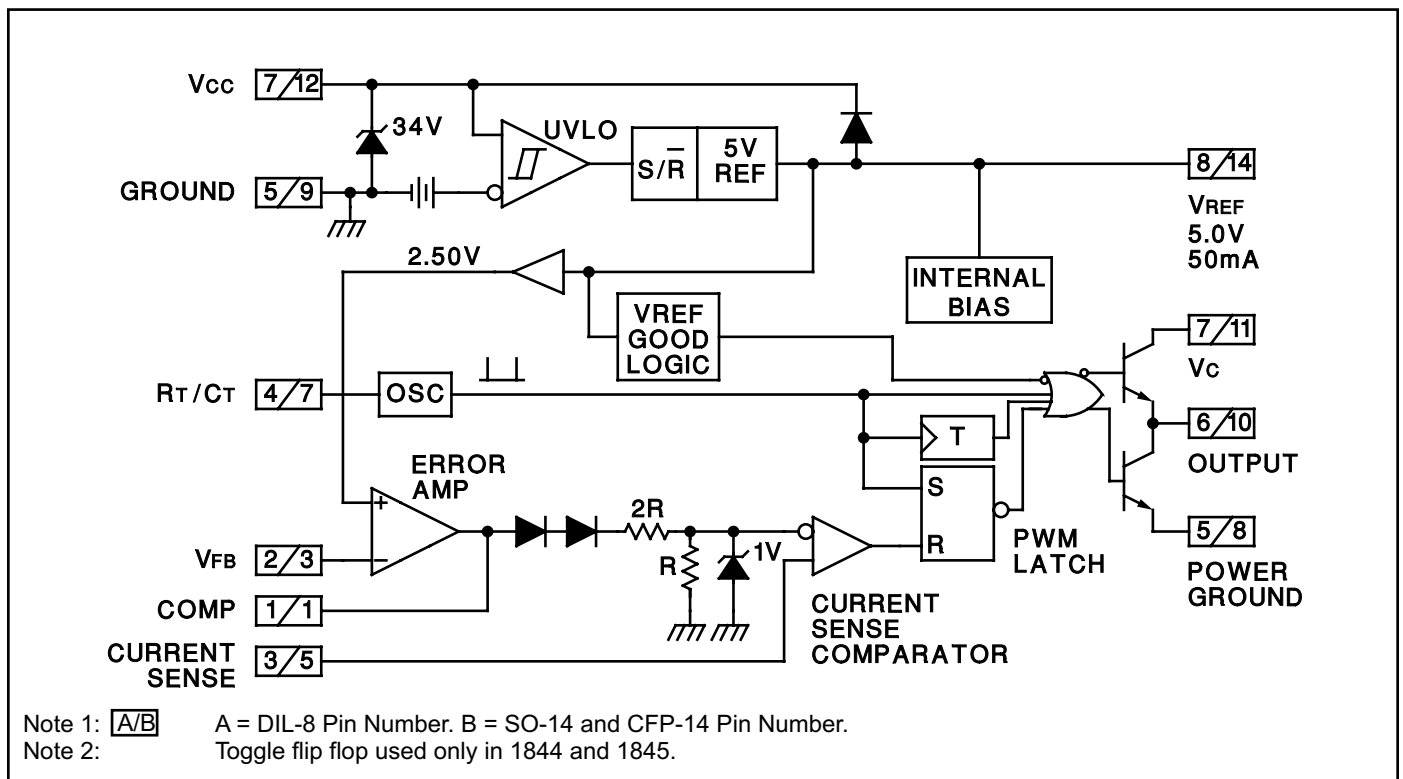

ABSOLUTE MAXIMUM RATINGS(Note 1)

Supply Voltage (Low Impedance Source) 30V
 Supply Voltage (I_{cc} < 30mA) Self Limiting
 Output Current. ±1A
 Output Energy (Capacitive Load) 5 μJ
 Analog Inputs (Pins 2, 3). -0.3V to +6.3V
 Error Amp Output Sink Current 10 mA
 Power Dissipation at T_A ≤ 25°C (DIL-8) 1 W
 Power Dissipation at T_A ≤ 25°C (SOIC-14) 725 mW
 Storage Temperature Range -65°C to +150°C
 Junction Temperature Range -55°C to +150°C
 Lead Temperature (soldering, 10 seconds). 300°C

Note 1: All voltages are with respect to Pin 5.
 All currents are positive into the specified terminal.
 Consult Packaging Section of Databook for thermal limitations and considerations of packages.

CONNECTION DIAGRAMS

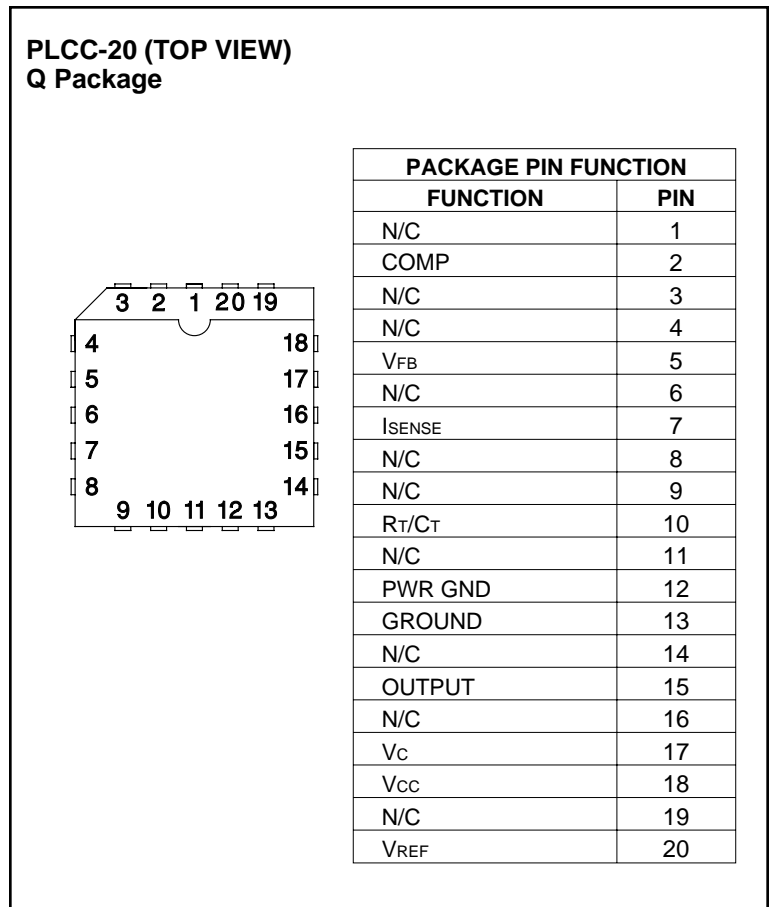
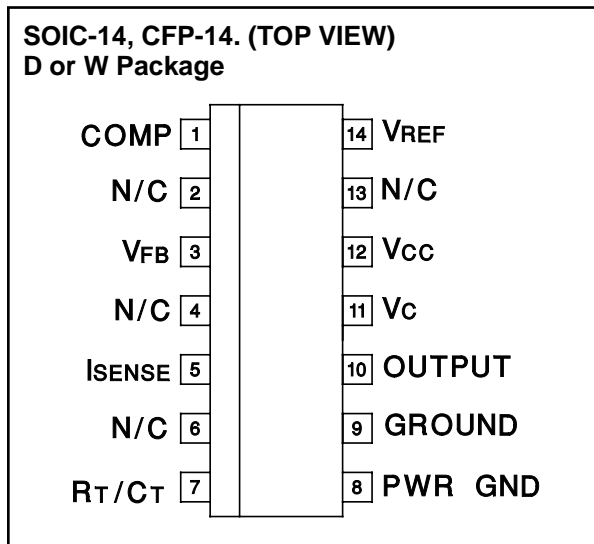
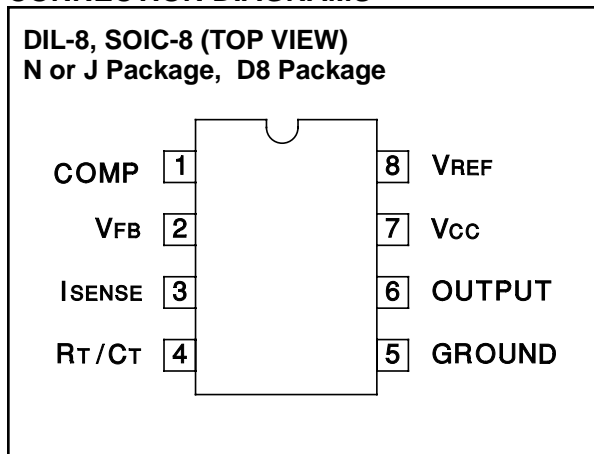

DISSIPATION RATING TABLE

Package	T _A ≤ 25°C Power Rating	Derating Factor Above T _A ≤ 25°C	T _A ≤ 70°C Power Rating	T _A ≤ 85°C Power Rating	T _A ≤ 125°C Power Rating
W	700 mW	5.5 mW/°C	452 mW	370 mW	150 mW

ELECTRICAL CHARACTERISTICS: Unless otherwise stated, these specifications apply for $-55^{\circ}\text{C} \leq T_A \leq 125^{\circ}\text{C}$ for the UC184X; $-40^{\circ}\text{C} \leq T_A \leq 85^{\circ}\text{C}$ for the UC284X; $0^{\circ}\text{C} \leq T_A \leq 70^{\circ}\text{C}$ for the 384X; $V_{CC} = 15\text{V}$ (Note 5); $R_T = 10\text{k}$; $C_T = 3.3\text{nF}$, $T_A = T_J$.

PARAMETER	TEST CONDITIONS	UC1842/3/4/5 UC2842/3/4/5			UC3842/3/4/5			UNITS
		MIN	TYP	MAX	MIN	TYP	MAX	
Reference Section								
Output Voltage	$T_J = 25^{\circ}\text{C}$, $I_o = 1\text{mA}$	4.95	5.00	5.05	4.90	5.00	5.10	V
Line Regulation	$12 \leq V_{IN} \leq 25\text{V}$		6	20		6	20	mV
Load Regulation	$1 \leq I_o \leq 20\text{mA}$		6	25		6	25	mV
Temp. Stability	(Note 2) (Note 7)		0.2	0.4		0.2	0.4	mV/ $^{\circ}\text{C}$
Total Output Variation	Line, Load, Temp. (Note 2)	4.9		5.1	4.82		5.18	V
Output Noise Voltage	$10\text{Hz} \leq f \leq 10\text{kHz}$, $T_J = 25^{\circ}\text{C}$ (Note 2)		50			50		μV
Long Term Stability	$T_A = 125^{\circ}\text{C}$, 1000Hrs. (Note 2)		5	25		5	25	mV
Output Short Circuit		-30	-100	-180	-30	-100	-180	mA
Oscillator Section								
Initial Accuracy	$T_J = 25^{\circ}\text{C}$ (Note 6)	47	52	57	47	52	57	kHz
Voltage Stability	$12 \leq V_{CC} \leq 25\text{V}$		0.2	1		0.2	1	%
Temp. Stability	$T_{MIN} \leq T_A \leq T_{MAX}$ (Note 2)		5			5		%
Amplitude	$V_{PIN 4}$ peak to peak (Note 2)		1.7			1.7		V
Error Amp Section								
Input Voltage	$V_{PIN 1} = 2.5\text{V}$	2.45	2.50	2.55	2.42	2.50	2.58	V
Input Bias Current			-0.3	-1		-0.3	-2	μA
AVOL	$2 \leq V_o \leq 4\text{V}$	65	90		65	90		dB
Unity Gain Bandwidth	(Note 2) $T_J = 25^{\circ}\text{C}$	0.7	1		0.7	1		MHz
PSRR	$12 \leq V_{CC} \leq 25\text{V}$	60	70		60	70		dB
Output Sink Current	$V_{PIN 2} = 2.7\text{V}$, $V_{PIN 1} = 1.1\text{V}$	2	6		2	6		mA
Output Source Current	$V_{PIN 2} = 2.3\text{V}$, $V_{PIN 1} = 5\text{V}$	-0.5	-0.8		-0.5	-0.8		mA
VOUT High	$V_{PIN 2} = 2.3\text{V}$, $R_L = 15\text{k}$ to ground	5	6		5	6		V
VOUT Low	$V_{PIN 2} = 2.7\text{V}$, $R_L = 15\text{k}$ to Pin 8		0.7	1.1		0.7	1.1	V
Current Sense Section								
Gain	(Notes 3 and 4)	2.85	3	3.15	2.85	3	3.15	V/V
Maximum Input Signal	$V_{PIN 1} = 5\text{V}$ (Note 3)	0.9	1	1.1	0.9	1	1.1	V
PSRR	$12 \leq V_{CC} \leq 25\text{V}$ (Note 3) (Note 2)		70			70		dB
Input Bias Current			-2	-10		-2	-10	μA
Delay to Output	$V_{PIN 3} = 0$ to 2V (Note 2)		150	300		150	300	ns

Note 2: These parameters, although guaranteed, are not 100% tested in production.

Note 3: Parameter measured at trip point of latch with $V_{PIN 2} = 0$.

Note 4: Gain defined as

$$A = \frac{\Delta V_{PIN 1}}{\Delta V_{PIN 3}}, 0 \leq V_{PIN 3} \leq 0.8\text{V}$$

Note 5: Adjust V_{CC} above the start threshold before setting at 15V.

Note 6: Output frequency equals oscillator frequency for the UC1842 and UC1843.

Output frequency is one half oscillator frequency for the UC1844 and UC1845.

Note 7: Temperature stability, sometimes referred to as average temperature coefficient, is described by the equation:

$$\text{Temp Stability} = \frac{V_{REF}(\text{max}) - V_{REF}(\text{min})}{T_J(\text{max}) - T_J(\text{min})}$$

$V_{REF}(\text{max})$ and $V_{REF}(\text{min})$ are the maximum and minimum reference voltages measured over the appropriate temperature range. Note that the extremes in voltage do not necessarily occur at the extremes in temperature.

ELECTRICAL CHARACTERISTICS: Unless otherwise stated, these specifications apply for $-55^{\circ}\text{C} \leq T_A \leq 125^{\circ}\text{C}$ for the UC184X; $-40^{\circ}\text{C} \leq T_A \leq 85^{\circ}\text{C}$ for the UC284X; $0^{\circ}\text{C} \leq T_A \leq 70^{\circ}\text{C}$ for the 384X; $V_{CC} = 15\text{V}$ (Note 5); $R_T = 10\text{k}$; $C_T = 3.3\text{nF}$, $T_A = T_J$.

PARAMETER	TEST CONDITION	UC1842/3/4/5 UC2842/3/4/5			UC3842/3/4/5			UNITS
		MIN	TYP	MAX	MIN	TYP	MAX	
Output Section								
Output Low Level	$I_{\text{SINK}} = 20\text{mA}$		0.1	0.4		0.1	0.4	V
	$I_{\text{SINK}} = 200\text{mA}$		1.5	2.2		1.5	2.2	V
Output High Level	$I_{\text{SOURCE}} = 20\text{mA}$	13	13.5		13	13.5		V
	$I_{\text{SOURCE}} = 200\text{mA}$	12	13.5		12	13.5		V
Rise Time	$T_J = 25^{\circ}\text{C}$, $C_L = 1\text{nF}$ (Note 2)		50	150		50	150	ns
Fall Time	$T_J = 25^{\circ}\text{C}$, $C_L = 1\text{nF}$ (Note 2)		50	150		50	150	ns
Under-voltage Lockout Section								
Start Threshold	X842/4	15	16	17	14.5	16	17.5	V
	X843/5	7.8	8.4	9.0	7.8	8.4	9.0	V
Min. Operating Voltage After Turn On	X842/4	9	10	11	8.5	10	11.5	V
	X843/5	7.0	7.6	8.2	7.0	7.6	8.2	V
PWM Section								
Maximum Duty Cycle	X842/3	95	97	100	95	97	100	%
	X844/5	46	48	50	47	48	50	%
Minimum Duty Cycle				0			0	%
Total Standby Current								
Start-Up Current			0.5	1		0.5	1	mA
Operating Supply Current	$V_{\text{PIN } 2} = V_{\text{PIN } 3} = 0\text{V}$		11	17		11	17	mA
Vcc Zener Voltage	$I_{\text{CC}} = 25\text{mA}$	30	34		30	34		V

Note 2: These parameters, although guaranteed, are not 100% tested in production.

Note 3: Parameter measured at trip point of latch with $V_{\text{PIN } 2} = 0$

Note 4: Gain defined as: $A = \frac{\Delta V_{\text{PIN } 1}}{\Delta V_{\text{PIN } 3}}$; $0 \leq V_{\text{PIN } 3} \leq 0.8\text{V}$.

Note 5: Adjust Vcc above the start threshold before setting at 15V.

Note 6: Output frequency equals oscillator frequency for the UC1842 and UC1843.

Output frequency is one half oscillator frequency for the UC1844 and UC1845.

ERROR AMP CONFIGURATION

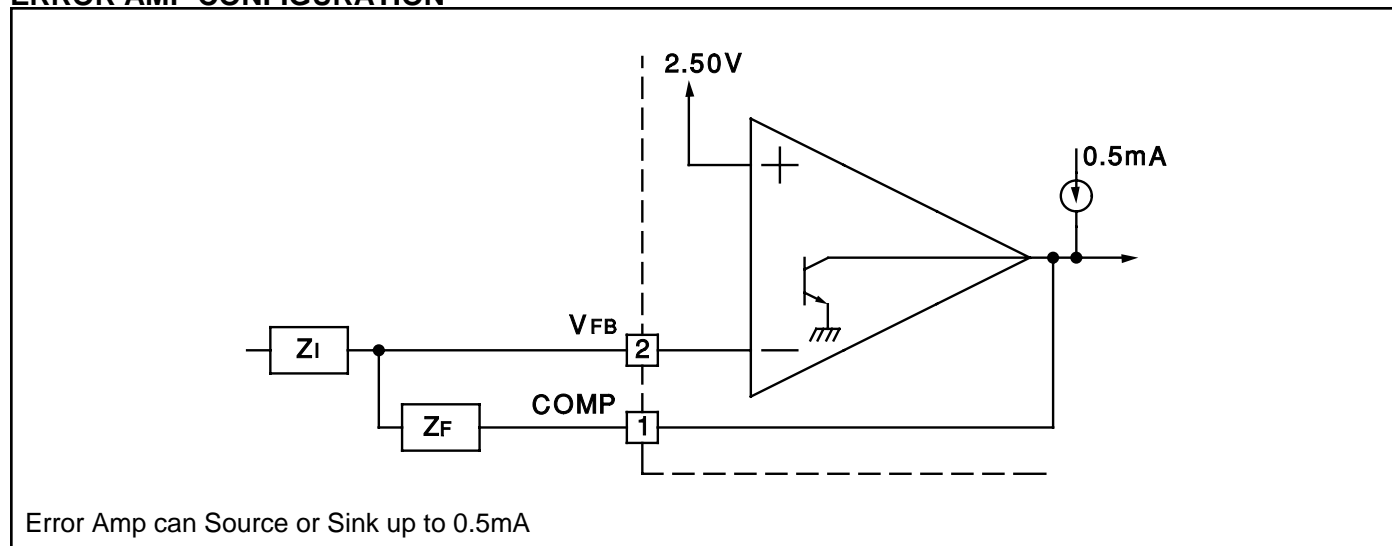

UNDER-VOLTAGE LOCKOUT

	UC1842	UC1843
	UC1844	UC1845
V _{ON}	16V	8.4V
V _{OFF}	10V	7.6V

During under-voltage lock-out, the output driver is biased to sink minor amounts of current. Pin 6 should be shunted to ground with a bleeder resistor to prevent activating the power switch with extraneous leakage currents.

CURRENT SENSE CIRCUIT

Peak Current (I_s) is Determined By The Formula

$$I_{SMAX} \approx \frac{1.0V}{RS}$$

A small RC filter may be required to suppress switch transients.

OSCILLATOR SECTION

For $RT > 5k$ $f \approx \frac{1.72}{RTCT}$

Deadtime vs CT (RT > 5k)

CT (nF)	td (μs)
1	0.3
2.2	0.6
4.7	1.2
10	2.4
22	4.8
47	9.6
100	19.2

Timing Resistance vs Frequency

FREQUENCY (Hz)	RT (kΩ) for CT = 100nF
100	172
1k	17.2
10k	1.72
100k	0.172
1M	0.0172

OUTPUT SATURATION CHARACTERISTICS

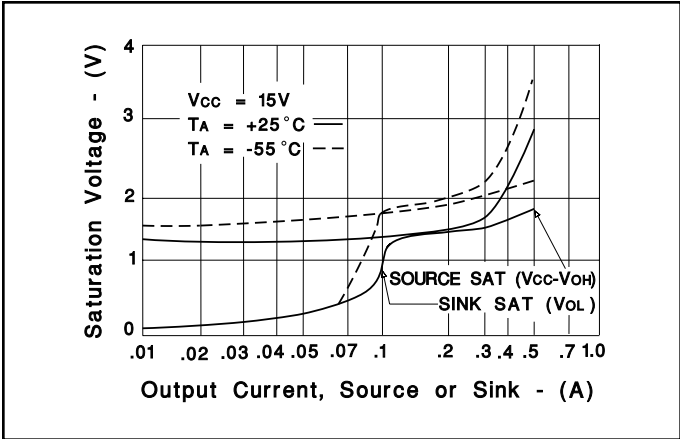

ERROR AMPLIFIER OPEN-LOOP FREQUENCY RESPONSE

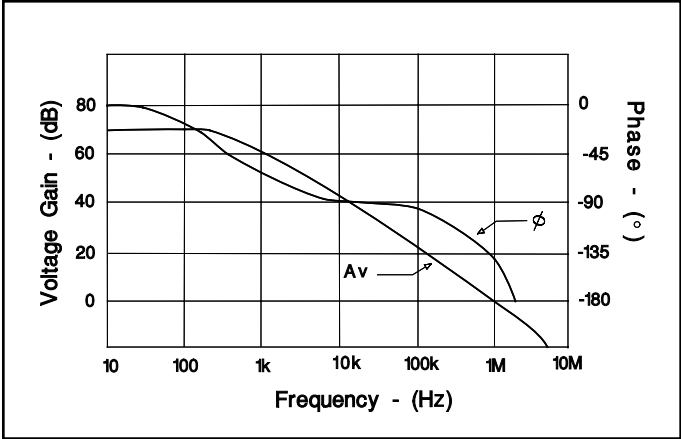

OPEN-LOOP LABORATORY FIXTURE

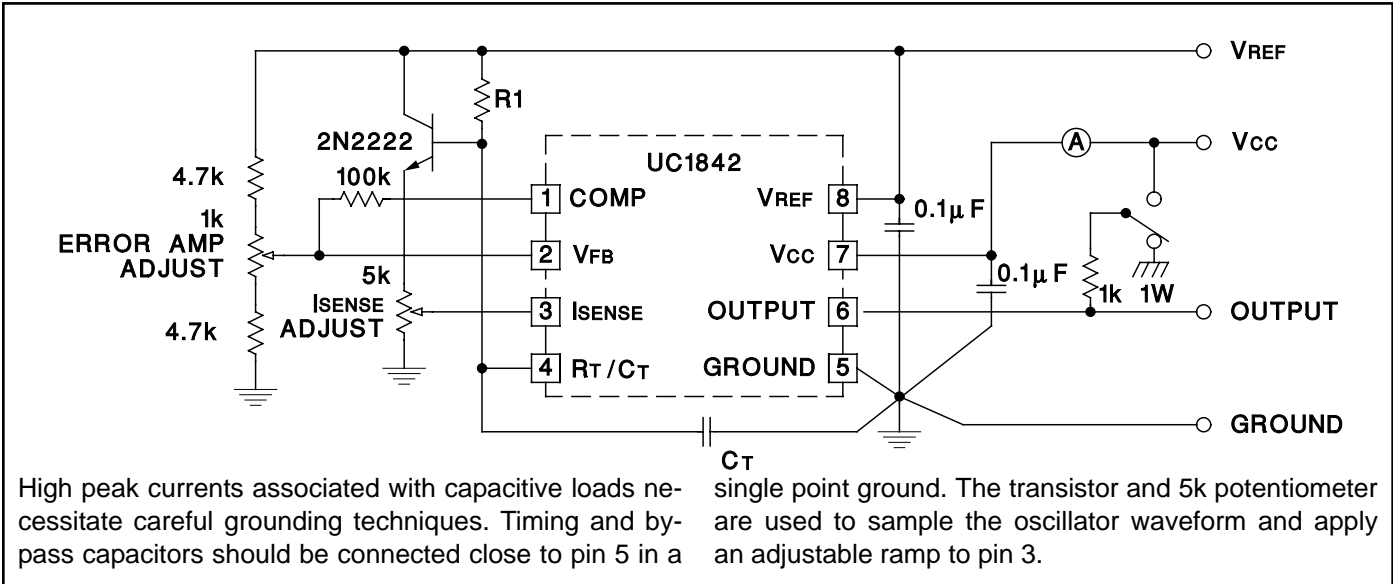

SHUT DOWN TECHNIQUES

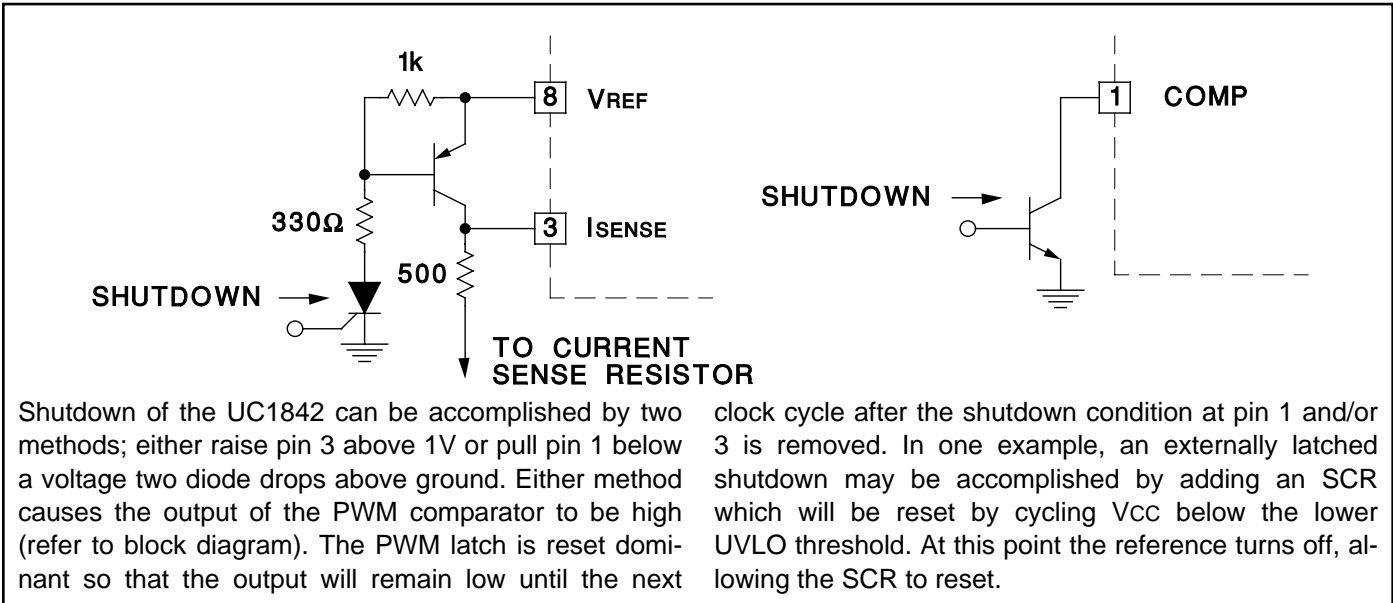

PACKAGING INFORMATION

Orderable Device	Status ⁽¹⁾	Package Type	Package Drawing	Pins	Package Qty	Eco Plan ⁽²⁾	Lead/Ball Finish	MSL Peak Temp ⁽³⁾
5962-8670401PA	ACTIVE	CDIP	JG	8	1	TBD	A42 SNPB	Level-NC-NC-NC
5962-8670401VPA	ACTIVE	CDIP	JG	8	1	TBD	Call TI	Level-NC-NC-NC
5962-8670401VXA	ACTIVE	LCCC	FK	20	1	TBD	Call TI	Level-NC-NC-NC
5962-8670401XA	ACTIVE	LCCC	FK	20	1	TBD	POST-PLATE	Level-NC-NC-NC
5962-8670402PA	ACTIVE	CDIP	JG	8	1	TBD	A42 SNPB	Level-NC-NC-NC
5962-8670402VPA	ACTIVE	CDIP	JG	8	1	TBD	Call TI	Level-NC-NC-NC
5962-8670402VXA	ACTIVE	LCCC	FK	20	1	TBD	Call TI	Level-NC-NC-NC
5962-8670402XA	ACTIVE	LCCC	FK	20	1	TBD	POST-PLATE	Level-NC-NC-NC
5962-8670403PA	ACTIVE	CDIP	JG	8	1	TBD	A42 SNPB	Level-NC-NC-NC
5962-8670403VPA	ACTIVE	CDIP	JG	8	1	TBD	Call TI	Level-NC-NC-NC
5962-8670403VXA	ACTIVE	LCCC	FK	20	1	TBD	Call TI	Level-NC-NC-NC
5962-8670403XA	ACTIVE	LCCC	FK	20	1	TBD	POST-PLATE	Level-NC-NC-NC
5962-8670404PA	ACTIVE	CDIP	JG	8	1	TBD	A42 SNPB	Level-NC-NC-NC
5962-8670404VPA	ACTIVE	CDIP	JG	8	1	TBD	Call TI	Level-NC-NC-NC
5962-8670404VXA	ACTIVE	LCCC	FK	20	1	TBD	Call TI	Level-NC-NC-NC
5962-8670404XA	ACTIVE	LCCC	FK	20	1	TBD	POST-PLATE	Level-NC-NC-NC
UC1842J	ACTIVE	CDIP	JG	8	1	TBD	A42 SNPB	Level-NC-NC-NC
UC1842J883B	ACTIVE	CDIP	JG	8	1	TBD	A42 SNPB	Level-NC-NC-NC
UC1842JQMLV	ACTIVE	CDIP	JG	8		TBD	Call TI	Call TI
UC1842L883B	ACTIVE	LCCC	FK	20	1	TBD	POST-PLATE	Level-NC-NC-NC
UC1842W	ACTIVE	CFP	W	14	1	TBD	A42 SNPB	Level-NC-NC-NC
UC1843J	ACTIVE	CDIP	JG	8	1	TBD	A42 SNPB	Level-NC-NC-NC
UC1843J883B	ACTIVE	CDIP	JG	8	1	TBD	A42 SNPB	Level-NC-NC-NC
UC1843JQMLV	ACTIVE	CDIP	JG	8		TBD	Call TI	Call TI
UC1843L	ACTIVE	LCCC	FK	20	1	TBD	POST-PLATE	Level-NC-NC-NC
UC1843L883B	ACTIVE	LCCC	FK	20	1	TBD	POST-PLATE	Level-NC-NC-NC
UC1843LQMLV	ACTIVE	LCCC	FK	20		TBD	Call TI	Call TI
UC1843W	ACTIVE	CFP	W	14	1	TBD	A42 SNPB	Level-NC-NC-NC
UC1844J	ACTIVE	CDIP	JG	8	1	TBD	A42 SNPB	Level-NC-NC-NC
UC1844J883B	ACTIVE	CDIP	JG	8	1	TBD	A42 SNPB	Level-NC-NC-NC
UC1844JQMLV	ACTIVE	CDIP	JG	8		TBD	Call TI	Call TI
UC1844L	ACTIVE	LCCC	FK	20	1	TBD	POST-PLATE	Level-NC-NC-NC
UC1844L883B	ACTIVE	LCCC	FK	20	1	TBD	POST-PLATE	Level-NC-NC-NC
UC1844LQMLV	ACTIVE	LCCC	FK	20		TBD	Call TI	Call TI
UC1844W	ACTIVE	CFP	W	14	1	TBD	A42 SNPB	Level-NC-NC-NC
UC1845J	ACTIVE	CDIP	JG	8	1	TBD	A42 SNPB	Level-NC-NC-NC
UC1845J883B	ACTIVE	CDIP	JG	8	1	TBD	A42 SNPB	Level-NC-NC-NC
UC1845JQMLV	ACTIVE	CDIP	JG	8		TBD	Call TI	Call TI
UC1845L	ACTIVE	LCCC	FK	20	1	TBD	POST-PLATE	Level-NC-NC-NC
UC1845L883B	ACTIVE	LCCC	FK	20	1	TBD	POST-PLATE	Level-NC-NC-NC
UC1845LQMLV	ACTIVE	LCCC	FK	20		TBD	Call TI	Call TI
UC1845W	ACTIVE	CFP	W	14	1	TBD	A42 SNPB	Level-NC-NC-NC

Orderable Device	Status ⁽¹⁾	Package Type	Package Drawing	Pins	Package Qty	Eco Plan ⁽²⁾	Lead/Ball Finish	MSL Peak Temp ⁽³⁾
UC2842D	ACTIVE	SOIC	D	14	50	TBD	CU NIPDAU	Level-1-220C-UNLIM
UC2842D8	ACTIVE	SOIC	D	8	75	TBD	CU NIPDAU	Level-2-220C-1 YEAR
UC2842D8TR	ACTIVE	SOIC	D	8	2500	TBD	CU NIPDAU	Level-2-220C-1 YEAR
UC2842DR	ACTIVE	SOIC	D	14		TBD	Call TI	Call TI
UC2842DTR	ACTIVE	SOIC	D	14	2500	TBD	CU NIPDAU	Level-1-220C-UNLIM
UC2842DW	ACTIVE	SOIC	DW	16	40	TBD	CU NIPDAU	Level-2-220C-1 YEAR
UC2842DWTR	ACTIVE	SOIC	DW	16	2000	TBD	CU NIPDAU	Level-2-220C-1 YEAR
UC2842J	OBSOLETE	CDIP	JG	8		TBD	Call TI	Call TI
UC2842N	ACTIVE	PDIP	P	8	50	TBD	CU NIPDAU	Level-NA-NA-NA
UC2842P	OBSOLETE	PDIP	P	8		TBD	Call TI	Call TI
UC2843D	ACTIVE	SOIC	D	14	50	TBD	CU NIPDAU	Level-1-220C-UNLIM
UC2843D8	ACTIVE	SOIC	D	8	75	TBD	CU NIPDAU	Level-2-220C-1 YEAR
UC2843D8TR	ACTIVE	SOIC	D	8	2500	TBD	CU NIPDAU	Level-2-220C-1 YEAR
UC2843D8TRG4	ACTIVE	SOIC	D	8	2500	TBD	CU NIPDAU	Level-2-220C-1 YEAR
UC2843DR	OBSOLETE	SOIC	D	14		TBD	Call TI	Call TI
UC2843DTR	ACTIVE	SOIC	D	14	2500	TBD	CU NIPDAU	Level-1-220C-UNLIM
UC2843J	OBSOLETE	CDIP	JG	8		TBD	Call TI	Call TI
UC2843N	ACTIVE	PDIP	P	8	50	TBD	CU NIPDAU	Level-NA-NA-NA
UC2844D	ACTIVE	SOIC	D	14	50	TBD	CU NIPDAU	Level-1-220C-UNLIM
UC2844D8	ACTIVE	SOIC	D	8	75	TBD	CU NIPDAU	Level-2-220C-1 YEAR
UC2844D8TR	ACTIVE	SOIC	D	8	2500	TBD	CU NIPDAU	Level-2-220C-1 YEAR
UC2844DTR	ACTIVE	SOIC	D	14	2500	TBD	CU NIPDAU	Level-1-220C-UNLIM
UC2844N	ACTIVE	PDIP	P	8	50	TBD	CU NIPDAU	Level-NA-NA-NA
UC2845D	ACTIVE	SOIC	D	14	50	TBD	CU NIPDAU	Level-1-220C-UNLIM
UC2845D8	ACTIVE	SOIC	D	8	75	TBD	CU NIPDAU	Level-2-220C-1 YEAR
UC2845D8TR	ACTIVE	SOIC	D	8	2500	Green (RoHS & no Sb/Br)	CU NIPDAU	Level-1-260C-UNLIM
UC2845DTR	ACTIVE	SOIC	D	14	2500	TBD	CU NIPDAU	Level-1-220C-UNLIM
UC2845J	OBSOLETE	CDIP	JG	8		TBD	Call TI	Call TI
UC2845N	ACTIVE	PDIP	P	8	50	TBD	CU NIPDAU	Level-NA-NA-NA
UC3842D	ACTIVE	SOIC	D	14	50	TBD	CU NIPDAU	Level-1-220C-UNLIM
UC3842D8	ACTIVE	SOIC	D	8	75	TBD	CU NIPDAU	Level-2-220C-1 YEAR
UC3842D8TR	ACTIVE	SOIC	D	8	2500	TBD	CU NIPDAU	Level-2-220C-1 YEAR
UC3842DTR	ACTIVE	SOIC	D	14	2500	TBD	CU NIPDAU	Level-1-220C-UNLIM
UC3842J	ACTIVE	CDIP	JG	8	1	TBD	A42 SNPB	Level-NC-NC-NC
UC3842N	ACTIVE	PDIP	P	8	50	TBD	CU NIPDAU	Level-NA-NA-NA
UC3842P	OBSOLETE	PDIP	P	8		TBD	Call TI	Call TI
UC3843D	ACTIVE	SOIC	D	14	50	TBD	CU NIPDAU	Level-1-220C-UNLIM
UC3843D8	ACTIVE	SOIC	D	8	75	TBD	CU NIPDAU	Level-2-220C-1 YEAR
UC3843D8TR	ACTIVE	SOIC	D	8	2500	TBD	CU NIPDAU	Level-2-220C-1 YEAR
UC3843DTR	ACTIVE	SOIC	D	14	2500	TBD	CU NIPDAU	Level-1-220C-UNLIM
UC3843J	ACTIVE	CDIP	JG	8	1	TBD	A42 SNPB	Level-NC-NC-NC
UC3843N	ACTIVE	PDIP	P	8	50	TBD	CU NIPDAU	Level-NA-NA-NA
UC3843P	OBSOLETE	PDIP	P	8		TBD	Call TI	Call TI

Orderable Device	Status ⁽¹⁾	Package Type	Package Drawing	Pins	Package Qty	Eco Plan ⁽²⁾	Lead/Ball Finish	MSL Peak Temp ⁽³⁾
UC3843QTR	OBSOLETE	PLCC	FN	20		TBD	Call TI	Call TI
UC3844D	ACTIVE	SOIC	D	14	50	TBD	CU NIPDAU	Level-1-220C-UNLIM
UC3844D8	ACTIVE	SOIC	D	8	75	TBD	CU NIPDAU	Level-2-220C-1 YEAR
UC3844D8TR	ACTIVE	SOIC	D	8	2500	TBD	CU NIPDAU	Level-2-220C-1 YEAR
UC3844DTR	ACTIVE	SOIC	D	14	2500	TBD	CU NIPDAU	Level-1-220C-UNLIM
UC3844J	ACTIVE	CDIP	JG	8	1	TBD	A42 SNPB	Level-NC-NC-NC
UC3844N	ACTIVE	PDIP	P	8	50	TBD	CU NIPDAU	Level-NA-NA-NA
UC3844P	OBSOLETE	PDIP	P	8		TBD	Call TI	Call TI
UC3845D	ACTIVE	SOIC	D	14	50	TBD	CU NIPDAU	Level-1-220C-UNLIM
UC3845D8	ACTIVE	SOIC	D	8	75	TBD	CU NIPDAU	Level-2-220C-1 YEAR
UC3845D8TR	ACTIVE	SOIC	D	8	2500	TBD	CU NIPDAU	Level-2-220C-1 YEAR
UC3845DG4	ACTIVE	SOIC	D	14	50	Green (RoHS & no Sb/Br)	CU NIPDAU	Level-2-260C-1 YEAR
UC3845DTR	ACTIVE	SOIC	D	14	2500	TBD	CU NIPDAU	Level-1-220C-UNLIM
UC3845DTRG4	ACTIVE	SOIC	D	14	2500	Green (RoHS & no Sb/Br)	CU NIPDAU	Level-2-260C-1 YEAR
UC3845J	ACTIVE	CDIP	JG	8	1	TBD	A42 SNPB	Level-NC-NC-NC
UC3845N	ACTIVE	PDIP	P	8	50	TBD	CU NIPDAU	Level-NA-NA-NA
UC3845NG4	ACTIVE	PDIP	P	8	50	TBD	CU NIPDAU	Level-NA-NA-NA
UC3845P	OBSOLETE	PDIP	P	8		TBD	Call TI	Call TI

⁽¹⁾ The marketing status values are defined as follows:

ACTIVE: Product device recommended for new designs.

LIFEBUY: TI has announced that the device will be discontinued, and a lifetime-buy period is in effect.

NRND: Not recommended for new designs. Device is in production to support existing customers, but TI does not recommend using this part in a new design.

PREVIEW: Device has been announced but is not in production. Samples may or may not be available.

OBSOLETE: TI has discontinued the production of the device.

⁽²⁾ Eco Plan - The planned eco-friendly classification: Pb-Free (RoHS) or Green (RoHS & no Sb/Br) - please check <http://www.ti.com/productcontent> for the latest availability information and additional product content details.

TBD: The Pb-Free/Green conversion plan has not been defined.

Pb-Free (RoHS): TI's terms "Lead-Free" or "Pb-Free" mean semiconductor products that are compatible with the current RoHS requirements for all 6 substances, including the requirement that lead not exceed 0.1% by weight in homogeneous materials. Where designed to be soldered at high temperatures, TI Pb-Free products are suitable for use in specified lead-free processes.

Green (RoHS & no Sb/Br): TI defines "Green" to mean Pb-Free (RoHS compatible), and free of Bromine (Br) and Antimony (Sb) based flame retardants (Br or Sb do not exceed 0.1% by weight in homogeneous material)

⁽³⁾ MSL, Peak Temp. -- The Moisture Sensitivity Level rating according to the JEDEC industry standard classifications, and peak solder temperature.

Important Information and Disclaimer: The information provided on this page represents TI's knowledge and belief as of the date that it is provided. TI bases its knowledge and belief on information provided by third parties, and makes no representation or warranty as to the accuracy of such information. Efforts are underway to better integrate information from third parties. TI has taken and continues to take reasonable steps to provide representative and accurate information but may not have conducted destructive testing or chemical analysis on incoming materials and chemicals. TI and TI suppliers consider certain information to be proprietary, and thus CAS numbers and other limited information may not be available for release.

In no event shall TI's liability arising out of such information exceed the total purchase price of the TI part(s) at issue in this document sold by TI to Customer on an annual basis.

JG (R-GDIP-T8)

CERAMIC DUAL-IN-LINE

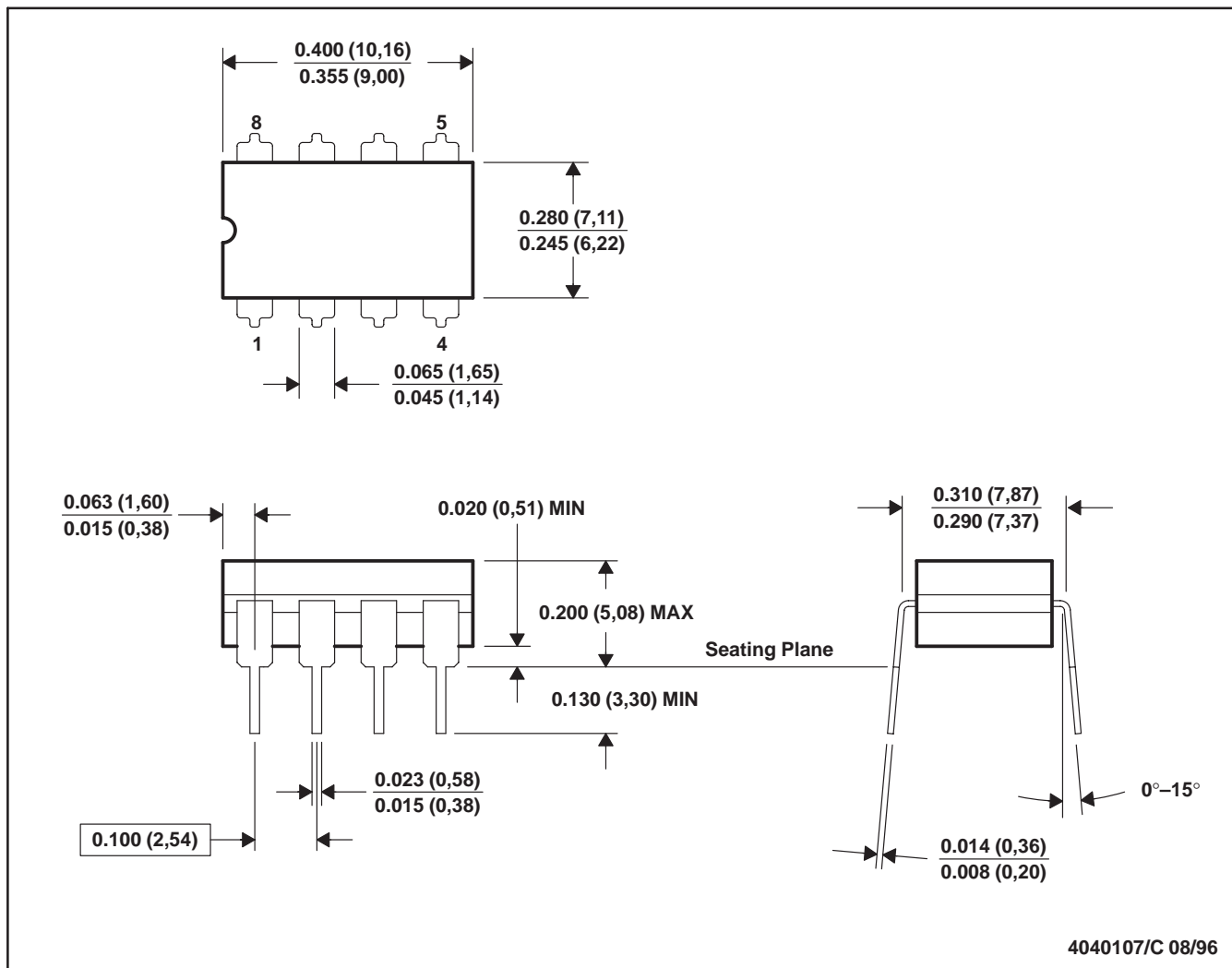

- NOTES: A. All linear dimensions are in inches (millimeters).
 B. This drawing is subject to change without notice.
 C. This package can be hermetically sealed with a ceramic lid using glass frit.
 D. Index point is provided on cap for terminal identification.
 E. Falls within MIL STD 1835 GDIP1-T8

W (R-GDFP-F14)

CERAMIC DUAL FLATPACK



4040180-2/D 07/03

- NOTES:
- A. All linear dimensions are in inches (millimeters).
 - B. This drawing is subject to change without notice.
 - C. This package can be hermetically sealed with a ceramic lid using glass frit.
 - D. Index point is provided on cap for terminal identification only.
 - E. Falls within MIL STD 1835 GDFP1-F14 and JEDEC MO-092AB

FK (S-CQCC-N**)

LEADLESS CERAMIC CHIP CARRIER

28 TERMINAL SHOWN



4040140/D 10/96

- NOTES:
- A. All linear dimensions are in inches (millimeters).
 - B. This drawing is subject to change without notice.
 - C. This package can be hermetically sealed with a metal lid.
 - D. The terminals are gold plated.
 - E. Falls within JEDEC MS-004

P (R-PDIP-T8)

PLASTIC DUAL-IN-LINE



- NOTES: A. All linear dimensions are in inches (millimeters).
 B. This drawing is subject to change without notice.
 C. Falls within JEDEC MS-001

For the latest package information, go to http://www.ti.com/sc/docs/package/pkg_info.htm



D (R-PDSO-G14)

PLASTIC SMALL-OUTLINE PACKAGE

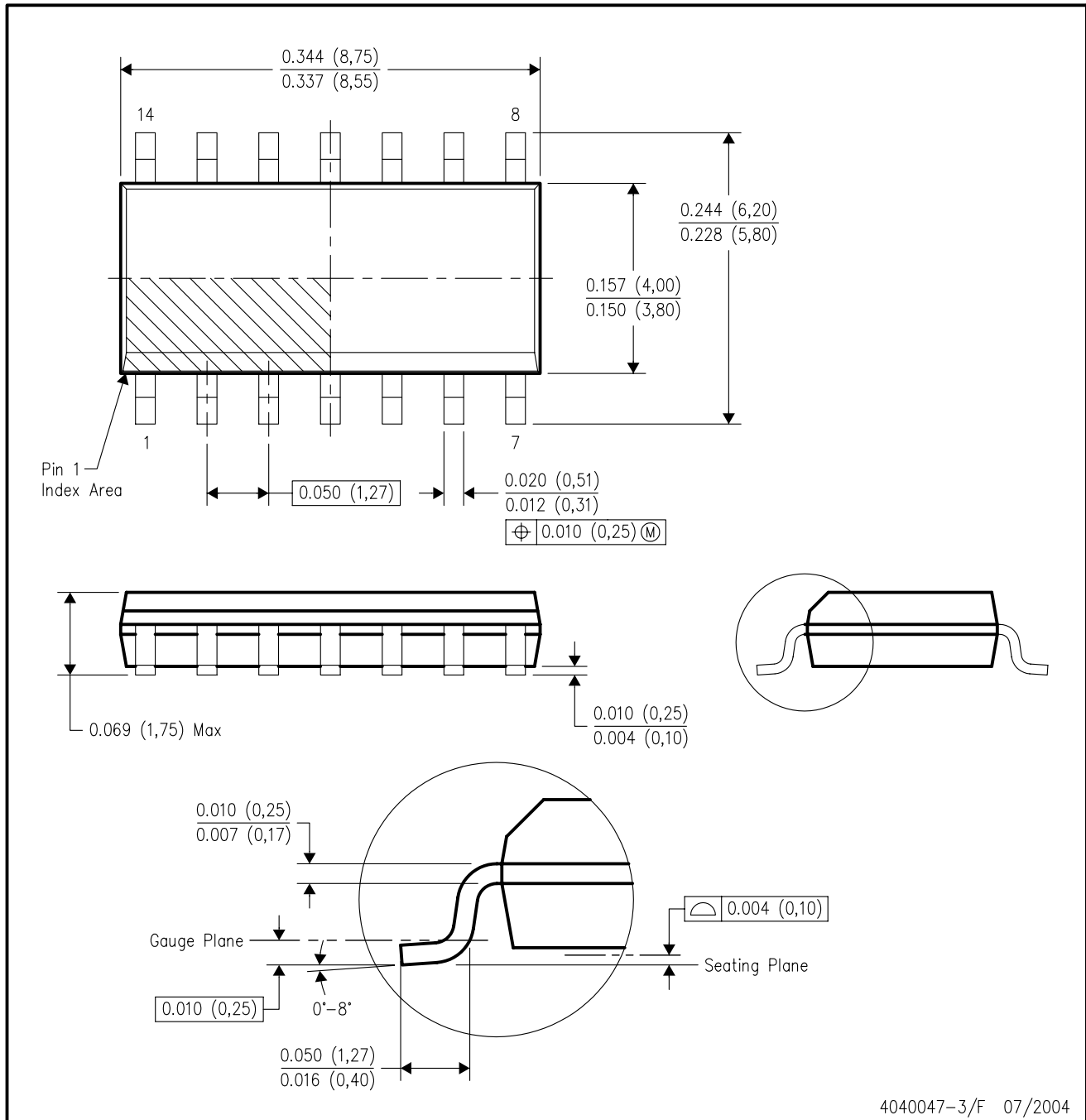

- NOTES:
- A. All linear dimensions are in inches (millimeters).
 - B. This drawing is subject to change without notice.
 - C. Body dimensions do not include mold flash or protrusion not to exceed 0.006 (0,15).
 - D. Falls within JEDEC MS-012 variation AB.

FN (S-PQCC-J**)

PLASTIC J-LEADED CHIP CARRIER

20 PIN SHOWN

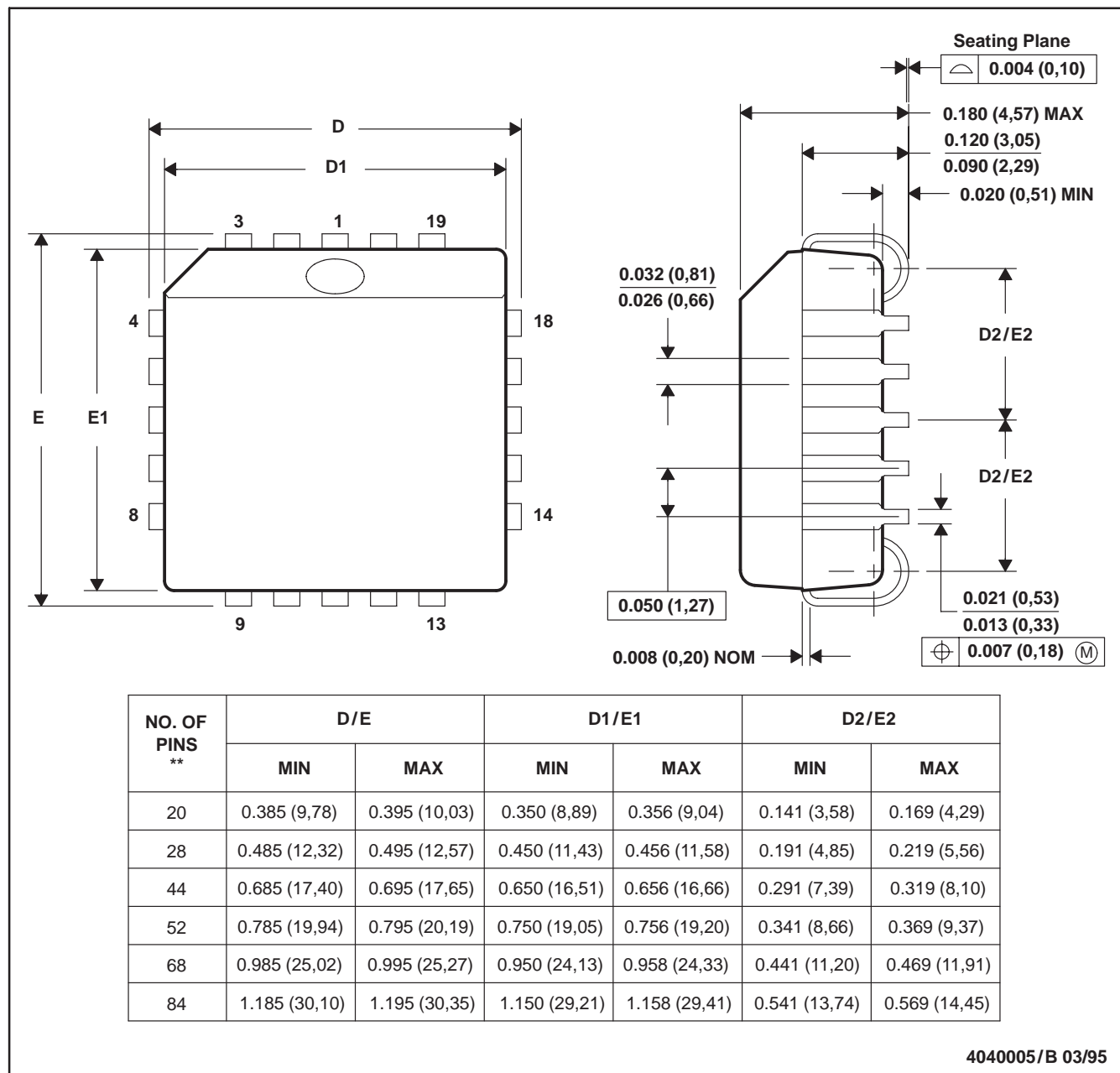

- NOTES: A. All linear dimensions are in inches (millimeters).
 B. This drawing is subject to change without notice.
 C. Falls within JEDEC MS-018

D (R-PDSO-G8)

PLASTIC SMALL-OUTLINE PACKAGE

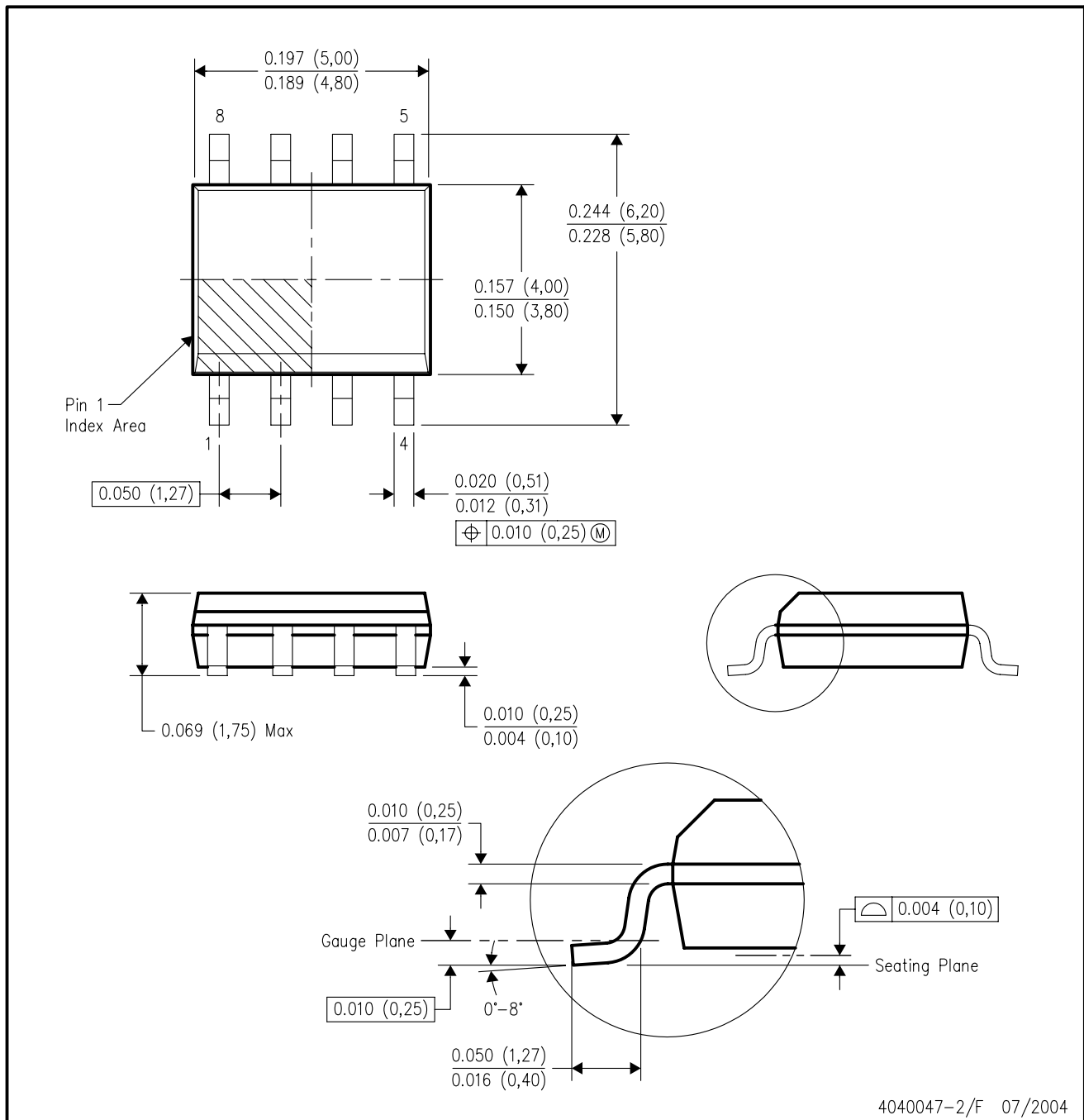

- NOTES:
- A. All linear dimensions are in inches (millimeters).
 - B. This drawing is subject to change without notice.
 - C. Body dimensions do not include mold flash or protrusion not to exceed 0.006 (0,15).
 - D. Falls within JEDEC MS-012 variation AA.

DW (R-PDSO-G16)

PLASTIC SMALL-OUTLINE PACKAGE

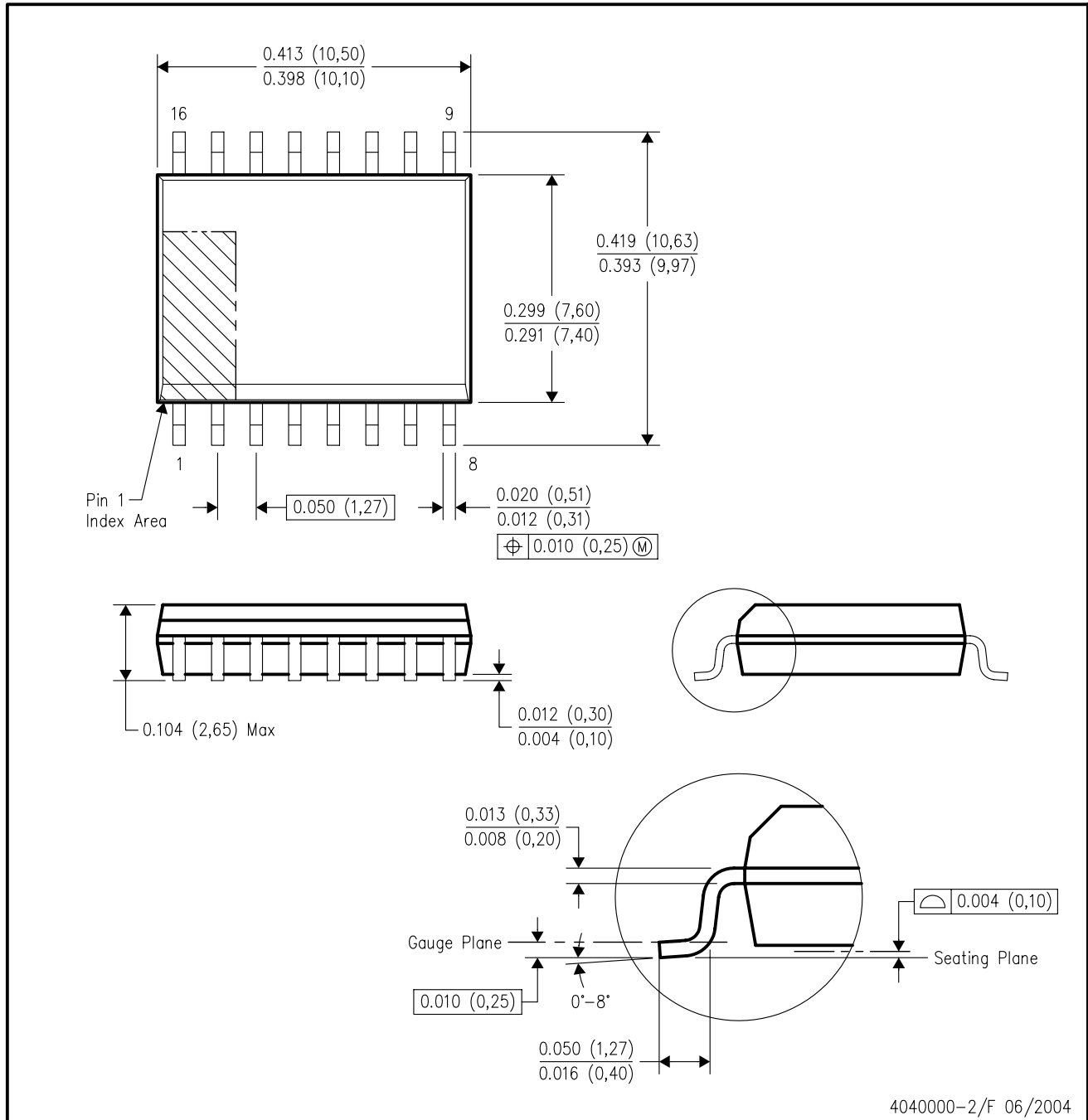

4040000-2/F 06/2004

- NOTES:
- A. All linear dimensions are in inches (millimeters).
 - B. This drawing is subject to change without notice.
 - C. Body dimensions do not include mold flash or protrusion not to exceed 0.006 (0,15).
 - D. Falls within JEDEC MS-013 variation AA.

IMPORTANT NOTICE

Texas Instruments Incorporated and its subsidiaries (TI) reserve the right to make corrections, modifications, enhancements, improvements, and other changes to its products and services at any time and to discontinue any product or service without notice. Customers should obtain the latest relevant information before placing orders and should verify that such information is current and complete. All products are sold subject to TI's terms and conditions of sale supplied at the time of order acknowledgment.

TI warrants performance of its hardware products to the specifications applicable at the time of sale in accordance with TI's standard warranty. Testing and other quality control techniques are used to the extent TI deems necessary to support this warranty. Except where mandated by government requirements, testing of all parameters of each product is not necessarily performed.

TI assumes no liability for applications assistance or customer product design. Customers are responsible for their products and applications using TI components. To minimize the risks associated with customer products and applications, customers should provide adequate design and operating safeguards.

TI does not warrant or represent that any license, either express or implied, is granted under any TI patent right, copyright, mask work right, or other TI intellectual property right relating to any combination, machine, or process in which TI products or services are used. Information published by TI regarding third-party products or services does not constitute a license from TI to use such products or services or a warranty or endorsement thereof. Use of such information may require a license from a third party under the patents or other intellectual property of the third party, or a license from TI under the patents or other intellectual property of TI.

Reproduction of information in TI data books or data sheets is permissible only if reproduction is without alteration and is accompanied by all associated warranties, conditions, limitations, and notices. Reproduction of this information with alteration is an unfair and deceptive business practice. TI is not responsible or liable for such altered documentation.

Resale of TI products or services with statements different from or beyond the parameters stated by TI for that product or service voids all express and any implied warranties for the associated TI product or service and is an unfair and deceptive business practice. TI is not responsible or liable for any such statements.

Following are URLs where you can obtain information on other Texas Instruments products and application solutions:

Products		Applications	
Amplifiers	amplifier.ti.com	Audio	www.ti.com/audio
Data Converters	dataconverter.ti.com	Automotive	www.ti.com/automotive
DSP	dsp.ti.com	Broadband	www.ti.com/broadband
Interface	interface.ti.com	Digital Control	www.ti.com/digitalcontrol
Logic	logic.ti.com	Military	www.ti.com/military
Power Mgmt	power.ti.com	Optical Networking	www.ti.com/opticalnetwork
Microcontrollers	microcontroller.ti.com	Security	www.ti.com/security
		Telephony	www.ti.com/telephony
		Video & Imaging	www.ti.com/video
		Wireless	www.ti.com/wireless

Mailing Address: Texas Instruments
Post Office Box 655303 Dallas, Texas 75265