

1.2 A/1.25 MHz, HIGH-EFFICIENCY STEP-DOWN CONVERTER

FEATURES

- Up to 95% Conversion Efficiency
- Typical Quiescent Current: 18 μ A
- Load Current: 1.2 A
- Operating Input Voltage Range: 2.5 V to 6.0 V
- Switching Frequency: 1.25 MHz
- Adjustable and Fixed Output Voltage
- Power Save Mode Operation at Light load Currents
- 100% Duty Cycle for Lowest Dropout
- Internal Softstart
- Dynamic Output Voltage Positioning
- Thermal Shutdown
- Short-Circuit Protection
- 10 Pin MSOP PowerPad™ Package
- 10 Pin QFN 3 X 3 mm Package

- USB Powered Modems
- CPUs and DSPs
- PC Cards and Notebooks
- xDSL Applications
- Standard 5-V to 3.3-V Conversion

DESCRIPTION

The TPS6204x family of devices are high efficiency synchronous step-down dc-dc converters optimized for battery powered portable applications. The devices are ideal for portable applications powered by a single Li-Ion battery cell or by 3-cell NiMH/NiCd batteries. With an output voltage range from 6.0 V down to 0.7 V, the devices support low voltage DSPs and processors in PDAs, pocket PCs, as well as notebooks and subnotebook computers. The TPS6204x operates at a fixed switching frequency of 1.25 MHz and enters the power save mode operation at light load currents to maintain high efficiency over the entire load current range. For low noise applications, the devices can be forced into fixed frequency PWM mode by pulling the MODE pin high. The TPS6204x supports up to 1.2-A load current.

APPLICATIONS

- PDA, Pocket PC and Smart Phones

Typical Application Circuit 1.2-A Output Current

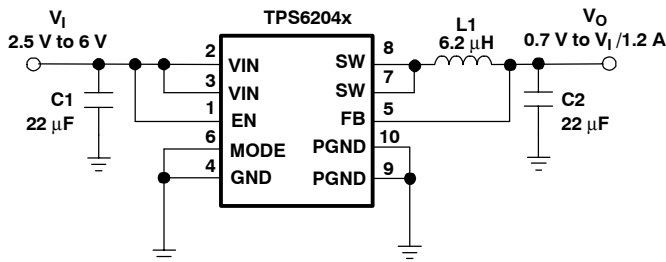

EFFICIENCY
vs
LOAD CURRENT

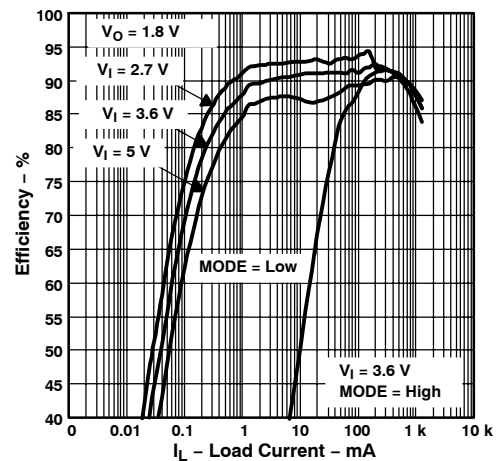

Please be aware that an important notice concerning availability, standard warranty, and use in critical applications of Texas Instruments semiconductor products and disclaimers thereto appears at the end of this data sheet.

PowerPAD is a trademark of Texas Instruments.



These devices have limited built-in ESD protection. The leads should be shorted together or the device placed in conductive foam during storage or handling to prevent electrostatic damage to the MOS gates.

ORDERING INFORMATION

T _A	VOLTAGE OPTIONS	PACKAGE		PACKAGE MARKING	
		MSOP ⁽¹⁾	QFN ⁽²⁾	MSOP	QFN
–40°C to 85°C	Adjustable	TPS62040DGQ	TPS62040DRC	BBI	BBO
	1.5 V	TPS62042DGQ	TPS62042DRC	BBL	BBS
	1.6 V	TPS62043DGQ	TPS62043DRC	BBM	BBT
	1.8 V	TPS62044DGQ	TPS62044DRC	BBN	BBU
	3.3 V	TPS62046DGQ	TPS62046DRC	BBQ	BBW

(1) The DGQ package is available in tape and reel. Add R suffix (DGQR) to order quantities of 2500 parts per reel.

(2) The DRC package is available in tape and reel. Add R suffix (DRCR) to order quantities of 3000 parts per reel.

ABSOLUTE MAXIMUM RATINGS

over operating free-air temperature range unless otherwise noted⁽¹⁾

	UNITS
Supply voltage VIN ⁽²⁾	–0.3 V to 7 V
Voltages on EN, MODE, FB, SW ⁽²⁾	–0.3 V to V _{CC} +0.3 V
Continuous power dissipation	See Dissipation Rating Table
Operating junction temperature range	–40°C to 150°C
Storage temperature range	–65°C to 150°C
Lead temperature (soldering, 10 sec)	260°C

(1) Stresses beyond those listed under “absolute maximum ratings” may cause permanent damage to the device. These are stress ratings only, and functional operation of the device at these or any other conditions beyond those indicated under *recommended operating conditions* is not implied. Exposure to absolute-maximum-rated conditions for extended periods may affect device reliability.

(2) All voltage values are with respect to network ground terminal.

PACKAGE DISSIPATION RATINGS

PACKAGE	R _{θJA} ⁽¹⁾	T _A ≤ 25°C POWER RATING	T _A = 70°C POWER RATING	T _A = 85°C POWER RATING
MSOP	60°C/W	1.67 W	917 mW	667 mW
QFN	48.7°C/W	2.05 W	1.13 W	821 mW

(1) The thermal resistance, R_{θJA} is based on a soldered PowerPAD using thermal vias.

RECOMMENDED OPERATING CONDITIONS

	MIN	TYP	MAX	UNIT
V _I Supply voltage	2.5		6.0	V
V _O Output voltage range for adjustable output voltage version	0.7		V _I	V
I _O Output current			1.2	A
L Inductor ⁽¹⁾		6.2		μH
C _I Input capacitor ⁽¹⁾		22		μF
C _O Output capacitor ⁽¹⁾		22		μF
T _A Operating ambient temperature	–40		85	°C
T _J Operating junction temperature	–40		125	°C

(1) Refer to application section for further information

ELECTRICAL CHARACTERISTICS

$V_I = 3.6\text{ V}$, $V_O = 1.8\text{ V}$, $I_O = 600\text{ mA}$, $EN = VIN$, $T_A = -40^\circ\text{C}$ to 85°C , typical values are at $T_A = 25^\circ\text{C}$ (unless otherwise noted)⁽¹⁾

SUPPLY CURRENT						
PARAMETER		TEST CONDITIONS	MIN	TYP	MAX	UNIT
V_I	Input voltage range		2.5		6.0	V
$I_{(Q)}$	Operating quiescent current	$I_O = 0\text{ mA}$, device is not switching		18	35	μA
I_{SD}	Shutdown supply current	$EN = \text{GND}$		0.1	1	μA
V_{UVLO}	Under-voltage lockout threshold		1.5		2.3	V
ENABLE AND MODE						
V_{EN}	EN high level input voltage		1.4			V
V_{EN}	EN low level input voltage				0.4	V
I_{EN}	EN input bias current	$EN = \text{GND}$ or VIN		0.01	1.0	μA
$V_{(MODE)}$	MODE high level input voltage		1.4			V
$V_{(MODE)}$	MODE low level input voltage				0.4	V
$I_{(MODE)}$	MODE input bias current	MODE = GND or VIN		0.01	1.0	μA
POWER SWITCH						
$r_{DS(ON)}$	P-channel MOSFET on-resistance	$V_I = V_{GS} = 3.6\text{ V}$		115	210	$\text{m}\Omega$
	P-channel MOSFET on-resistance	$V_I = V_{GS} = 2.5\text{ V}$		145	270	$\text{m}\Omega$
$I_{lkg(P)}$	P-channel leakage current	$V_{DS} = 6.0\text{ V}$			1	μA
$r_{DS(ON)}$	N-channel MOSFET on-resistance	$V_I = V_{GS} = 3.6\text{ V}$		85	200	$\text{m}\Omega$
	N-channel MOSFET on-resistance	$V_I = V_{GS} = 2.5\text{ V}$		115	280	$\text{m}\Omega$
$I_{lkg(N)}$	N-channel leakage current	$V_{DS} = 6.0\text{ V}$			1	μA
I_L	P-channel current limit	$2.5\text{ V} < V_I < 6.0\text{ V}$	1.5	1.85	2.2	A
	Thermal shutdown			150		$^\circ\text{C}$
OSCILLATOR						
f_S	Oscillator frequency	$V_{FB} = 0.5\text{ V}$	1	1.25	1.5	MHz
		$V_{FB} = 0\text{ V}$		625		kHz
OUTPUT						
V_O	Adjustable output voltage range	TPS62040		0.7	V_{IN}	V
V_{ref}	Reference voltage			0.5		V
V_{FB}	Feedback voltage	TPS62040 Adjustable	$V_I = 2.5\text{ V}$ to 6.0 V ; $I_O = 0\text{ mA}$ $V_I = 2.5\text{ V}$ to 6.0 V ; $0\text{ mA} \leq I_O \leq 1.2\text{ A}$	0% -3%	3% 3%	
V_O	Fixed output voltage	TPS62042 1.5V	$V_I = 2.5\text{ V}$ to 6.0 V ; $I_O = 0\text{ mA}$ $V_I = 2.5\text{ V}$ to 6.0 V ; $0\text{ mA} \leq I_O \leq 1.2\text{ A}$	0% -3%	3% 3%	
		TPS62043 1.6V	$V_I = 2.5\text{ V}$ to 6.0 V ; $I_O = 0\text{ mA}$ $V_I = 2.5\text{ V}$ to 6.0 V ; $0\text{ mA} \leq I_O \leq 1.2\text{ A}$	0% -3%	3% 3%	
		TPS62044 1.8V	$V_I = 2.5\text{ V}$ to 6.0 V ; $I_O = 0\text{ mA}$ $V_I = 2.5\text{ V}$ to 6.0 V ; $0\text{ mA} \leq I_O \leq 1.2\text{ A}$	0% -3%	3% 3%	
		TPS62046 3.3V	$V_I = 3.6\text{ V}$ to 6.0 V ; $I_O = 0\text{ mA}$ $V_I = 3.6\text{ V}$ to 6.0 V ; $0\text{ mA} \leq I_O \leq 1.2\text{ A}$	0% -3%	3% 3%	
	Line regulation ⁽¹⁾		$V_I = V_O + 0.5\text{ V}$ (min. 2.5 V) to 6.0 V , $I_O = 10\text{ mA}$		0	%/V
	Load regulation ⁽¹⁾		$I_O = 10\text{ mA}$ to 1200 mA		0	%/mA
$I_{lkg(SW)}$	Leakage current into SW pin		$V_I > V_O$, $0\text{ V} \leq V_{SW} \leq V_I$	0.1	1	μA
	Reverse leakage current into pin SW		$V_I = \text{open}$; $EN = \text{GND}$; $V_{SW} = 6.0\text{ V}$	0.1	1	μA
f	Short circuit switching frequency		$V_{FB} = 0\text{ V}$	625		kHz

⁽¹⁾ The line and load regulations are digitally controlled to assure an output voltage accuracy of $\pm 3\%$.

PIN ASSIGNMENTS

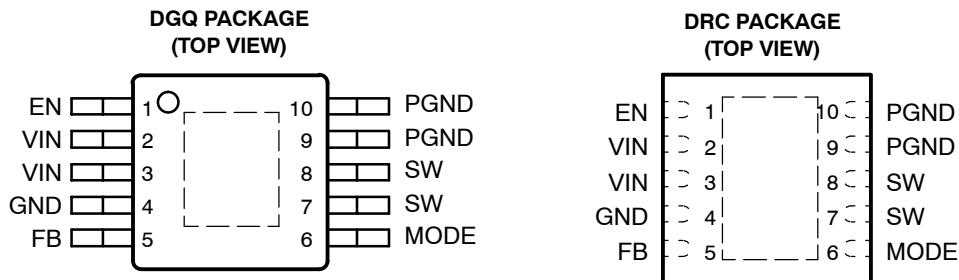

NOTE: The PowerPAD must be connected to GND.

Terminal Functions

TERMINAL NAME	NO.	I/O	DESCRIPTION
EN	1	I	Enable. Pulling EN to ground forces the device into shutdown mode. Pulling EN to V_I enables the device. EN should not be left floating and must be terminated.
VIN	2,3	I	Supply voltage input
GND	4		Analog ground
FB	5	I	Feedback pin. Connect FB directly to the output if the fixed output voltage version is used. For the adjustable version an external resistor divider is connected to this pin. The internal voltage divider is disabled for the adjustable version.
MODE	6	I	Pulling the MODE pin high allows the device to be forced into fixed frequency operation. Pulling the MODE pin to low enables the power save mode where the device operates in fixed frequency PWM mode at high load currents and in PFM mode (pulse frequency modulation) at light load currents.
SW	7,8	I/O	This is the switch pin of the converter and is connected to the drain of the internal power MOSFETs
PGND	9,10		Power ground

FUNCTIONAL BLOCK DIAGRAM

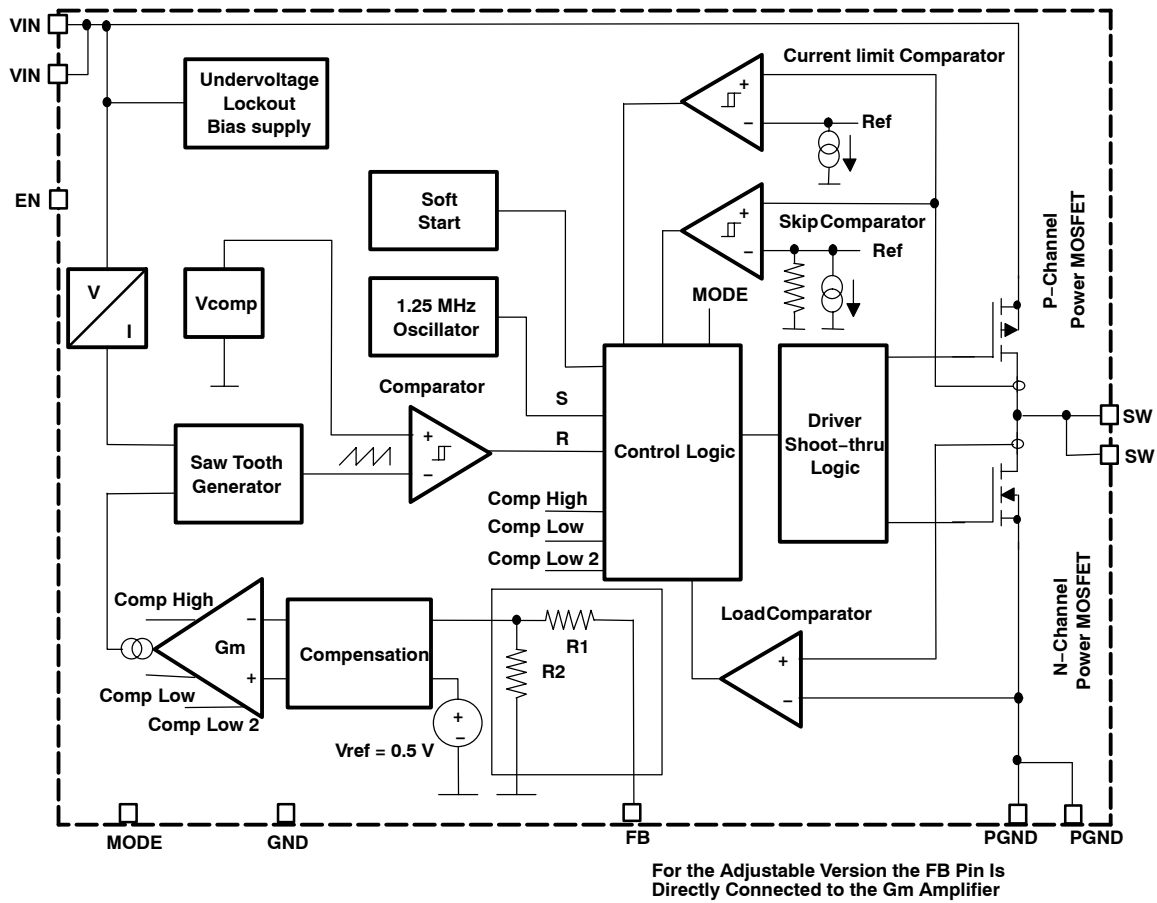

TYPICAL CHARACTERISTICS

TABLE OF GRAPHS

			FIGURE
η	Efficiency	vs Load current	1, 2, 3
η	Efficiency	vs Input voltage	4
I_Q	Quiescent current	vs Input voltage	5, 6
f_s	Switching frequency	vs Input voltage	7
$r_{DS(on)}$	P-Channel $r_{DS(on)}$	vs Input voltage	8
$r_{DS(on)}$	N-Channel rectifier $r_{DS(on)}$	vs Input voltage	9
	Load transient response		10
	PWM operation		11
	Power save mode		12
	Start-up		13

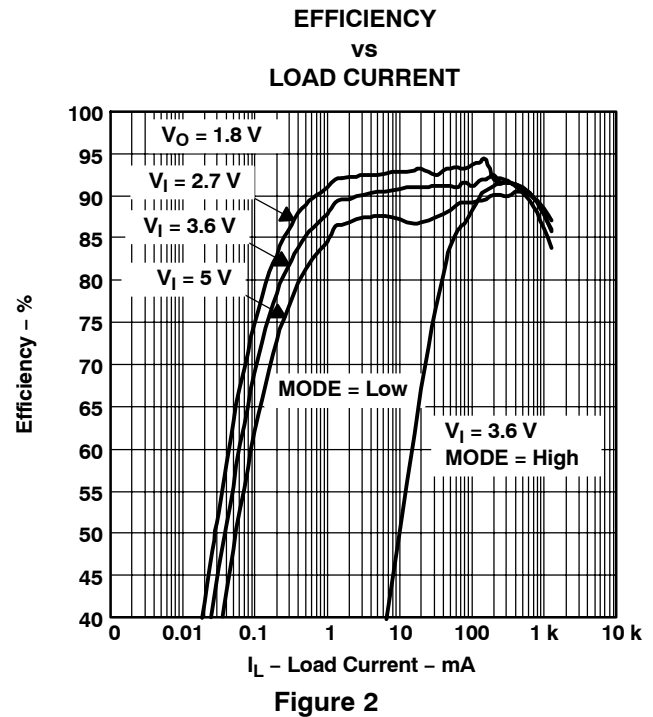
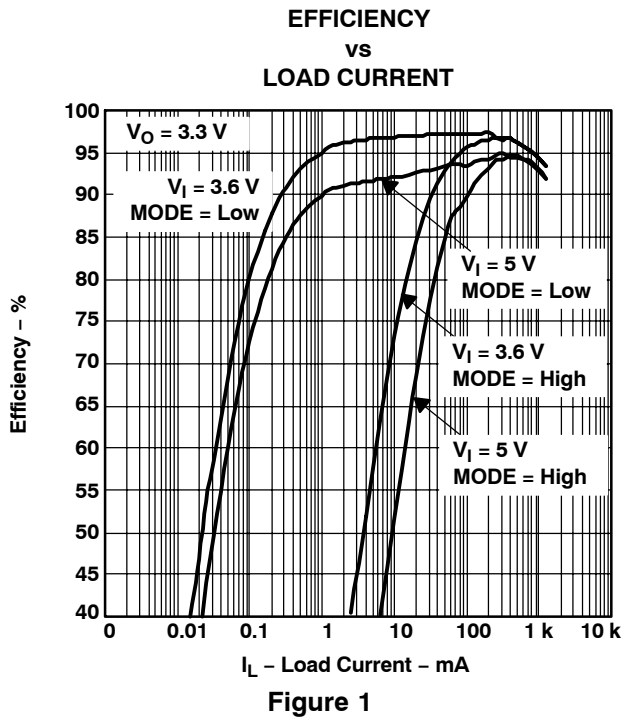

EFFICIENCY
vs
LOAD CURRENT

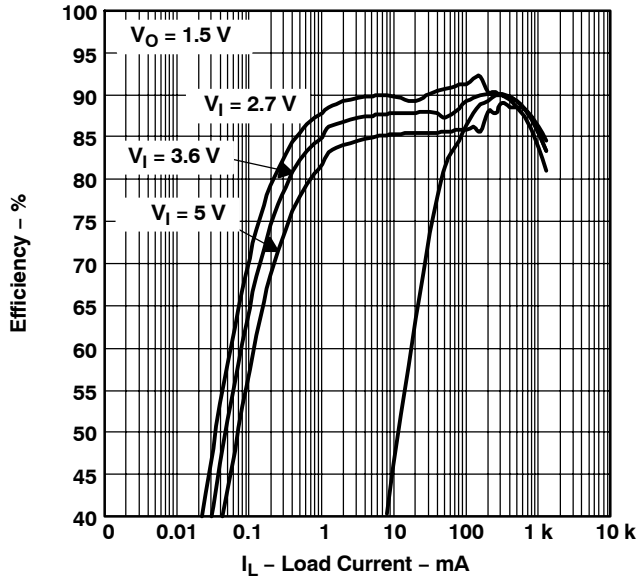

Figure 3

EFFICIENCY
vs
INPUT VOLTAGE

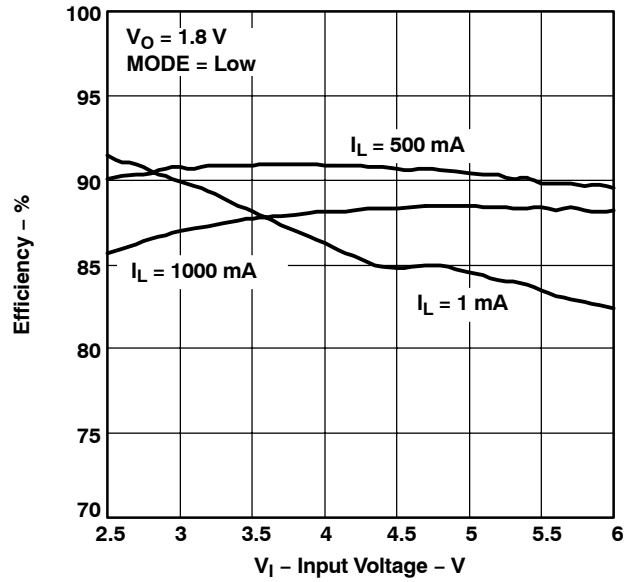

Figure 4

QUIESCENT CURRENT
vs
INPUT VOLTAGE

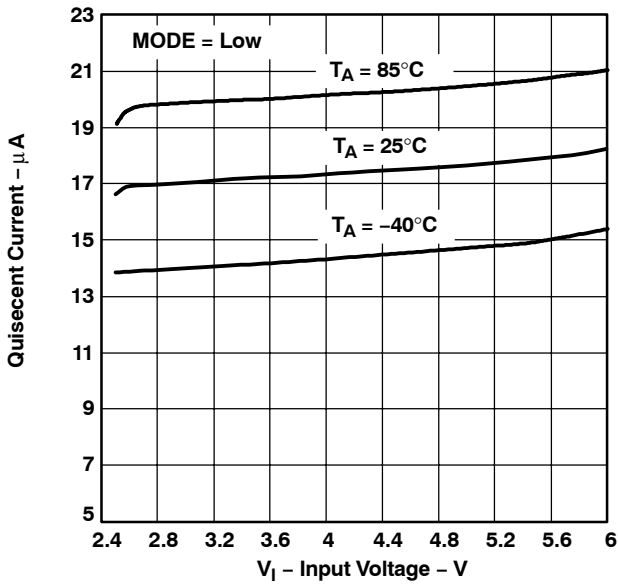

Figure 5

QUIESCENT CURRENT
vs
INPUT VOLTAGE

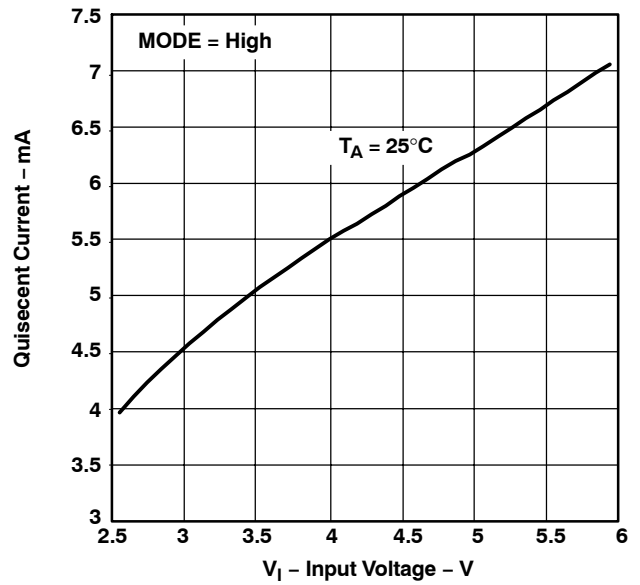

Figure 6

SWITCHING FREQUENCY
 vs
 INPUT VOLTAGE

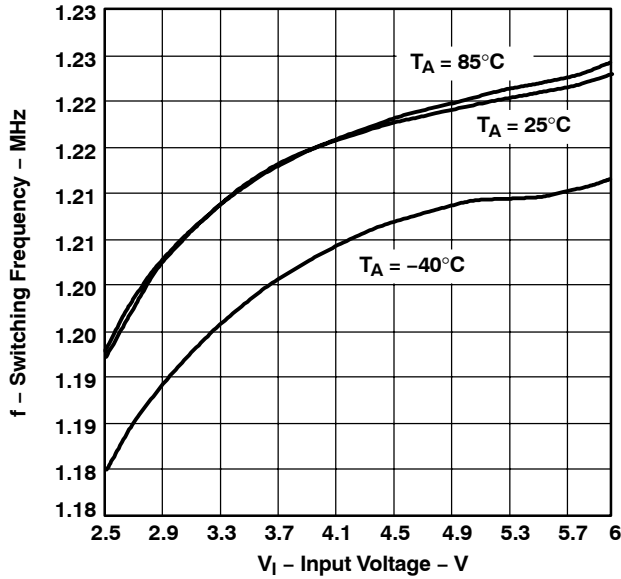

Figure 7

P-CHANNEL $r_{DS(on)}$
 vs
 INPUT VOLTAGE

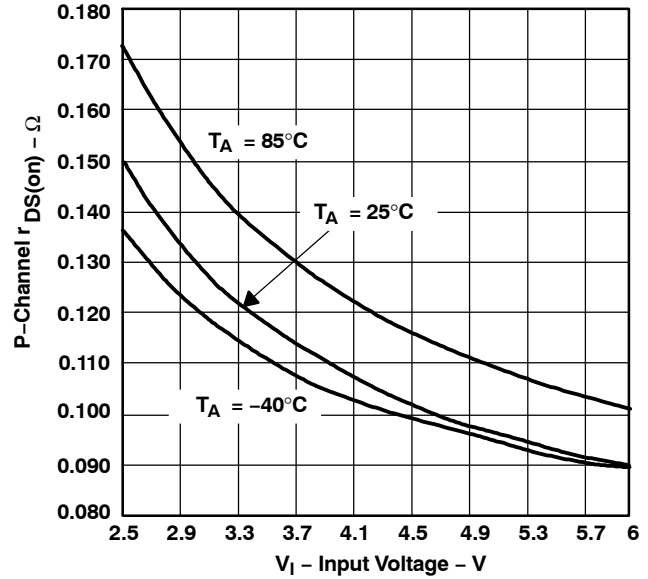

Figure 8

N-CHANNEL RECTIFIER $r_{DS(on)}$
 vs
 INPUT VOLTAGE

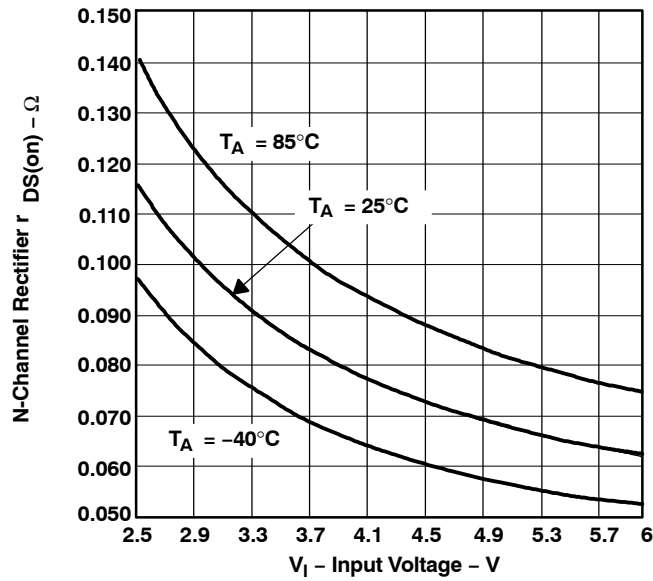

Figure 9

LOAD TRANSIENT RESPONSE

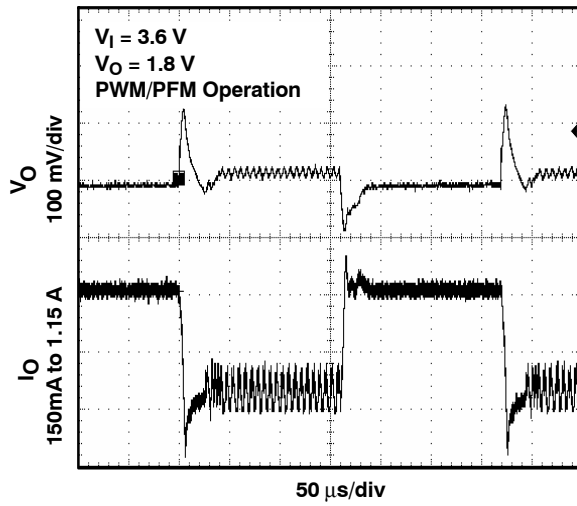

Figure 10

PWM OPERATION

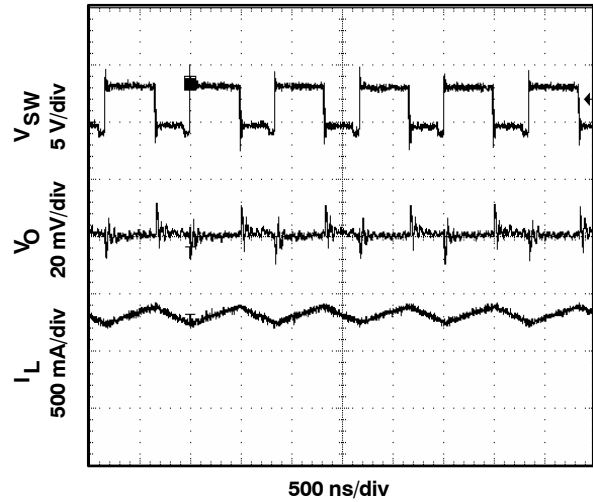

Figure 11

POWER SAVE MODE

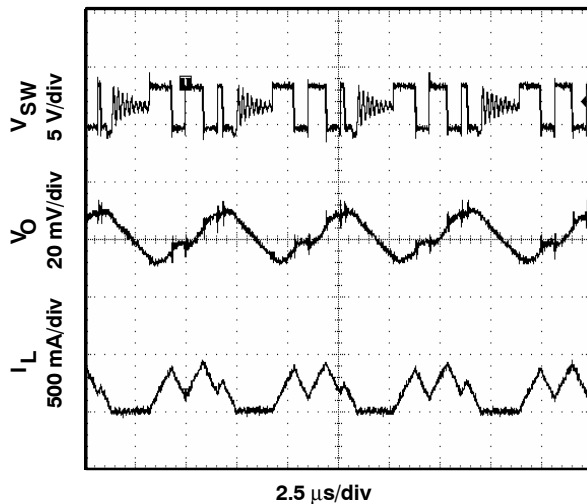

Figure 12

START-UP

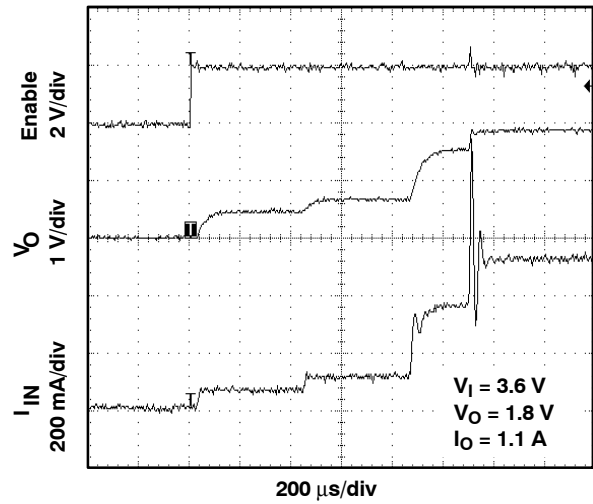

Figure 13

DETAILED DESCRIPTION

OPERATION

The TPS6204x is a synchronous step-down converter operating with typically 1.25 MHz fixed frequency. At moderate to heavy load currents, the device operates in pulse width modulation (PWM), and at light load currents, the device enters power save mode operation using pulse frequency modulation (PFM). When operating in PWM mode, the typical switching frequency is 1.25 MHz with a minimum switching frequency of 1 MHz. This makes the device suitable for xDSL applications minimizing RF (radio frequency) interference.

During PWM operation the converter uses a unique fast response voltage mode controller scheme with input voltage feed-forward to achieve good line and load regulation, allowing the use of small ceramic input and output capacitors. At the beginning of each clock cycle initiated by the clock signal (S) the P-channel MOSFET switch turns on and the inductor current ramps up until the comparator trips and the control logic turns off the switch. The current limit comparator also turns off the switch in case the current limit of the P-channel switch is exceeded. After the dead time preventing current shoot through, the N-channel MOSFET rectifier is turned on and the inductor current ramps down. The next cycle is initiated by the clock signal, again turning off the N-channel rectifier and turning on the P-channel switch.

The Gm amplifier as well as the input voltage determines the rise time of the saw tooth generator, and therefore, any change in input voltage or output voltage directly controls the duty cycle of the converter, giving a very good line and load transient regulation.

POWER SAVE MODE OPERATION

As the load current decreases, the converter enters power save mode operation. During power save mode the converter operates with reduced switching frequency in PFM mode and with a minimum quiescent current maintaining high efficiency.

The converter monitors the average inductor current and the device enters power save mode when the average inductor current is below the threshold. The transition point between PWM and power save mode is given by the transition current with the following equation:

$$I_{\text{transition}} = \frac{V_I}{18.66 \Omega} \quad (1)$$

During power save mode the output voltage is monitored with the comparator by the threshold's comp low and comp high. As the output voltage falls below the comp low threshold set to typically 0.8% above the nominal output voltage, the P-channel switch turns on. The P-channel switch remains on until the transition current (1) is reached. Then the N-channel switch turns on completing the first cycle. The converter continues to switch with its normal duty cycle determined by the input and output voltage but with half the nominal switching frequency of 625-kHz typ. Thus the output voltage rises and as soon as the output voltage reaches the comp high threshold of 1.6%, the converter stops switching. Depending on the load current, the converter switches for a longer or shorter period of time in order to deliver the energy to the output. If the load current increases and the output voltage can not be maintained with the transition current, equation (1), the converter enters PWM again. See Figure 11 and Figure 12 under the typical graphs section and Figure 14 for power save mode operation. Among other techniques this advanced power save mode method allows high efficiency over the entire load current range and a small output ripple of typically 1% of the nominal output voltage.

Setting the power save mode thresholds to typically 0.8% and 1.6% above the nominal output voltage at light load current results in a dynamic voltage positioning achieving lower absolute voltage drops during heavy load transient changes. This allows the converter to operate with small output capacitors like 22 μ F and still having a low absolute voltage drop during heavy load transient. Refer to Figure 14 as well for detailed operation of the power save mode.

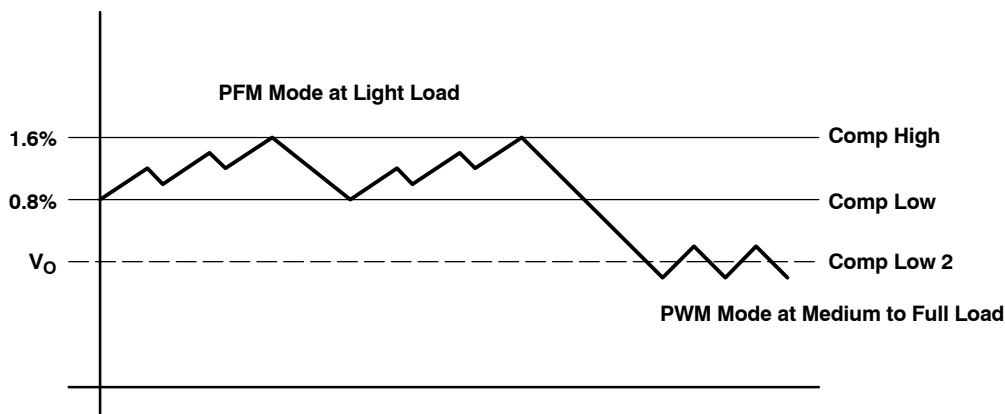

Figure 14. Power Save Mode Thresholds and Dynamic Voltage Positioning

The converter enters the fixed frequency PWM mode as soon as the output voltage falls below the comp low 2 threshold.

DYNAMIC VOLTAGE POSITIONING

As described in the power save mode operation sections before and as detailed in Figure 14 the output voltage is typically 0.8% (i.e., 1% on average) above the nominal output voltage at light load currents, as the device is in power save mode. This gives additional headroom for the voltage drop during a load transient from light load to full load. In the other direction during a load transient from full load to light load the voltage overshoot is also minimized by turning on the N-Channel rectifier switch to pull the output voltage actively down.

MODE (AUTOMATIC PWM/PFM OPERATION AND FORCED PWM OPERATION)

Connecting the MODE pin to GND enables the automatic PWM and power save mode operation. The converter operates in fixed frequency PWM mode at moderate to heavy loads and in the PFM mode during light loads, maintaining high efficiency over a wide load current range.

Pulling the MODE pin high forces the converter to operate constantly in the PWM mode even at light load currents. The advantage is the converter operates with a fixed switching frequency that allows simple filtering of the switching frequency for noise sensitive applications. In this mode, the efficiency is lower compared to the power save mode during light loads (see Figure 1 to Figure 3). For additional flexibility it is possible to switch from power save mode to forced PWM mode during operation. This allows efficient power management by adjusting the operation of the TPS6204x to the specific system requirements.

100% DUTY CYCLE LOW DROPOUT OPERATION

The TPS6204x offers a low input to output voltage difference while still maintaining regulation with the use of the 100% duty cycle mode. In this mode, the P-Channel switch is constantly turned on. This is particularly useful in battery powered applications to achieve longest operation time by taking full advantage of the whole battery voltage range. i.e. The minimum input voltage to maintain regulation depends on the load current and output voltage and can be calculated as:

$$V_{I \min} = V_{O \max} + I_{O \max} \times (r_{DS(on) \max} + R_L) \quad (2)$$

with:

$I_{O(max)}$ = maximum output current plus inductor ripple current

$r_{DS(on)max}$ = maximum P-channel switch $t_{DS(on)}$.

R_L = DC resistance of the inductor

V_{Omax} = nominal output voltage plus maximum output voltage tolerance

SOFTSTART

The TPS6204x series has an internal softstart circuit that limits the inrush current during start up. This prevents possible voltage drops of the input voltage in case a battery or a high impedance power source is connected to the input of the TPS6204x.

The softstart is implemented with a digital circuit increasing the switch current in steps of typically $I_{LIM}/8$, $I_{LIM}/4$, $I_{LIM}/2$ and then the typical switch current limit 1.85 A as specified in the electrical parameter table. The start-up time mainly depends on the output capacitor and load current, see Figure 13.

SHORT-CIRCUIT PROTECTION

As soon as the output voltage falls below 50% of the nominal output voltage, the converter switching frequency as well as the current limit is reduced to 50% of the nominal value. Since the short-circuit protection is enabled during start-up, the device does not deliver more than half of its nominal current limit until the output voltage exceeds 50% of the nominal output voltage. This needs to be considered in case a load acting as a current sink is connected to the output of the converter.

THERMAL SHUTDOWN

As soon as the junction temperature of typically 150°C is exceeded the device goes into thermal shutdown. In this mode, the P-Channel switch and N-Channel rectifier are turned off. The device continues its operation when the junction temperature falls below typically 150°C again.

ENABLE

Pulling the EN low forces the part into shutdown mode, with a shutdown current of typically 0.1 μ A. In this mode, the P-Channel switch and N-Channel rectifier are turned off and the whole device is in shut down. If an output voltage is present during shut down, which could be an external voltage source or super cap, the reverse leakage current is specified under electrical parameter table. For proper operation the enable (EN) pin must be terminated and should not be left floating.

Pulling EN high starts up the TPS6204x with the softstart as described under the section Softstart.

UNDERVOLTAGE LOCKOUT

The undervoltage lockout circuit prevents device misoperation at low input voltages. It prevents the converter from turning on the switch or rectifier MOSFET with undefined conditions.

APPLICATION INFORMATION

ADJUSTABLE OUTPUT VOLTAGE VERSION

When the adjustable output voltage version TPS62040 is used, the output voltage is set by the external resistor divider. See Figure 15.

The output voltage is calculated as:

$$V_O = 0.5 \text{ V} \times \left(1 + \frac{R1}{R2} \right) \quad (3)$$

with $R1 + R2 \leq 1 \text{ M}\Omega$ and internal reference voltage V_{ref} typical = 0.5 V

$R1 + R2$ should not be greater than 1 M Ω because of stability reasons. To keep the operating quiescent current to a minimum, the feedback resistor divider should have high impedance with $R1+R2 \leq 1 \text{ M}\Omega$. Due to this and the low reference voltage of $V_{ref} = 0.5 \text{ V}$, the noise on the feedback pin (FB) needs to be minimized. Using a capacitive divider C1 and C2 across the feedback resistors minimizes the noise at the feedback, without degrading the line or load transient performance.

C1 and C2 should be selected as:

$$C1 = \frac{1}{2 \times \pi \times 10 \text{ kHz} \times R1} \quad (4)$$

with:

R1 = upper resistor of voltage divider

C1 = upper capacitor of voltage divider

For C1 a value should be chosen that comes closest to the calculated result.

$$C2 = \frac{R1}{R2} \times C1 \quad (5)$$

with:

R2 = lower resistor of voltage divider

C2 = lower capacitor of voltage divider

For C2, the selected capacitor value should always be selected larger than the calculated result. For example, in Figure 15 for C2 100 pF are selected for a calculated result of $C2 = 88.42 \text{ pF}$.

If quiescent current is not a key design parameter C1 and C2 can be omitted, and a low impedance feedback divider has to be used with $R1 + R2 < 100 \text{ k}\Omega$. This reduces the noise available on the feedback pin (FB) as well but increases the overall quiescent current during operation. The higher the programmed output voltage the lower the feedback impedance has to be for best operation when not using C1 and C2.

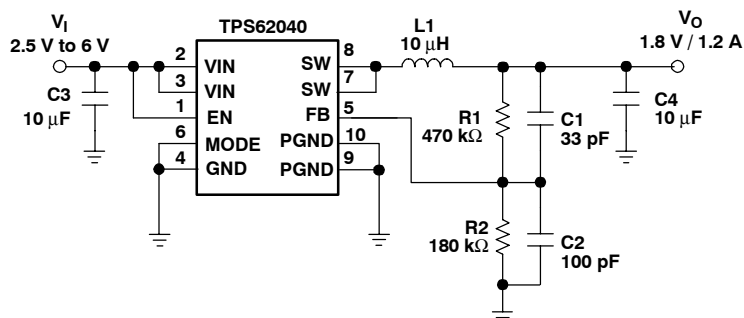

Figure 15. Adjustable Output Voltage Version

Inductor Selection

The TPS6204x typically uses a 6.2-μH output inductor. Larger or smaller inductor values can be used to optimize the performance of the device for specific operation conditions. The selected inductor has to be rated for its dc resistance and saturation current. The dc resistance of the inductance directly influences the efficiency of the converter. Therefore an inductor with the lowest dc resistance should be selected for highest efficiency.

Formula (7) calculates the maximum inductor current under static load conditions. The saturation current of the inductor should be rated higher than the maximum inductor current as calculated with formula (7). This is needed because during heavy load transient the inductor current rises above the value calculated under (7).

$$\Delta I_L = V_O \times \frac{1 - \frac{V_O}{V_I}}{L \times f} \quad (6)$$

$$I_{L \max} = I_{O \max} + \frac{\Delta I_L}{2} \quad (7)$$

with

f = Switching frequency (1.25 MHz typical)

L = Inductor value

ΔI_L = Peak-to-peak inductor ripple current

$I_{L \max}$ = Maximum inductor current

The highest inductor current occurs at maximum V_I .

Open core inductors have a soft saturation characteristic and they can usually handle higher inductor currents versus a comparable shielded inductor. A more conservative approach is to select the inductor current rating just for the maximum switch current of 2.2 A for the TPS6204x. Keep in mind that the core material from inductor to inductor differs and has an impact on the efficiency, especially at high switching frequencies. Refer to Table 1 and the typical applications and inductors selection.

Table 1. Inductor Selection

INDUCTOR VALUE	DIMENSIONS	COMPONENT SUPPLIER
4.7 μH	5,0 mm × 5,0 mm × 3,0 mm	Sumida CDRH4D28C-4.7
4.7 μH	5,2 mm × 5,2 mm × 2,5 mm	Coiltronics SD25-4R7
5.3 μH	5,7 mm × 5,7 mm × 3,0 mm	Sumida CDRH5D28-5R3
6.2 μH	5,7 mm × 5,7 mm × 3,0 mm	Sumida CDRH5D28-6R2
6.0 μH	7,0 mm × 7,0 mm × 3,0 mm	Sumida CDRH6D28-6R0

Output Capacitor Selection

The advanced fast response voltage mode control scheme of the TPS6204x allows the use of small ceramic capacitors with a typical value of 22 μF without having large output voltage under and overshoots during heavy load transients. Ceramic capacitors having low ESR values have the lowest output voltage ripple and are recommended. If required, tantalum capacitors may also be used. Refer to Table 2 for component selection.

If ceramic output capacitor are used, the capacitor RMS ripple current rating always meets the application requirements. Just for completeness the RMS ripple current is calculated as:

$$I_{\text{RMS}C_{\text{out}}} = V_{\text{O}} \times \frac{1 - \frac{V_{\text{O}}}{V_{\text{I}}}}{L \times f} \times \frac{1}{2 \times \sqrt{3}} \quad (8)$$

At nominal load current the device operates in PWM mode and the overall output voltage ripple is the sum of the voltage spike caused by the output capacitor ESR plus the voltage ripple caused by charging and discharging the output capacitor:

$$\Delta V_{\text{O}} = V_{\text{O}} \times \frac{1 - \frac{V_{\text{O}}}{V_{\text{I}}}}{L \times f} \times \left(\frac{1}{8 \times C_{\text{O}} \times f} + \text{ESR} \right) \quad (9)$$

Where the highest output voltage ripple occurs at the highest input voltage, V_{I} .

At light load currents, the device operates in power save mode and the output voltage ripple is independent of the output capacitor value. The output voltage ripple is set by the internal comparator thresholds. The typical output voltage ripple is 1% of the nominal output voltage.

Input Capacitor Selection

Because of the nature of the buck converter having a pulsating input current, a low ESR input capacitor is required for best input voltage filtering and minimizing the interference with other circuits caused by high input voltage spikes. The input capacitor should have a minimum value of 22 μF . The input capacitor can be increased without any limit for better input voltage filtering.

Table 2. Input and Output Capacitor Selection

CAPACITOR VALUE	CASE SIZE	COMPONENT SUPPLIER	COMMENTS
22 μF	1206	Taiyo Yuden JMK316BJ226ML	Ceramic
22 μF	1210	Taiyo Yuden JMK325BJ226MM	Ceramic

Layout Considerations

For all switching power supplies, the layout is an important step in the design especially at high peak currents and switching frequencies. If the layout is not carefully done, the regulator might show stability problems as well as EMI problems. Therefore, use wide and short traces for the main current paths as indicated in bold in Figure 16. These traces should be routed first. The input capacitor should be placed as close as possible to the IC pins as well as the inductor and output capacitor. The feedback resistor network should be routed away from the inductor and switch node to minimize noise and magnetic interference. To further minimize noise from coupling into the feedback network and feedback pin, the ground plane or ground traces should be used for shielding. A common ground plane or a star ground as shown below should be used. This becomes very important especially at high switching frequencies of 1.25 MHz.

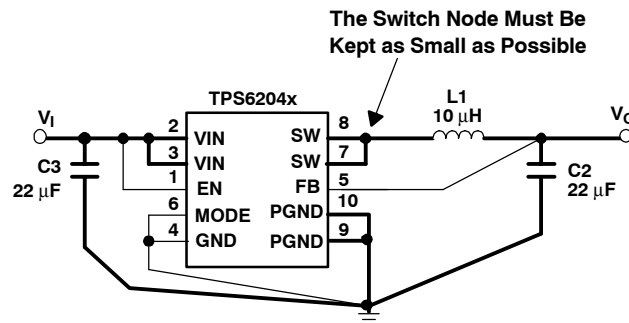

Figure 16. Layout Diagram

THERMAL INFORMATION

One of the most influential components on the thermal performance of a package is board design. In order to take full advantage of the heat dissipating abilities of the PowerPAD™ packages, a board should be used that acts similar to a heat sink and allows for the use of the exposed (and solderable), deep downset pad. For further information please refer to Texas Instruments application note (SLMA002) *PowerPAD Thermally Enhanced Package*.

The PowerPAD™ of the 10-pin MSOP package has an area of 1,52 mm × 1,79 mm (± 0,05 mm) and must be soldered to the PCB to lower the thermal resistance. Thermal vias to the next layer further reduce the thermal resistance.

TYPICAL APPLICATIONS

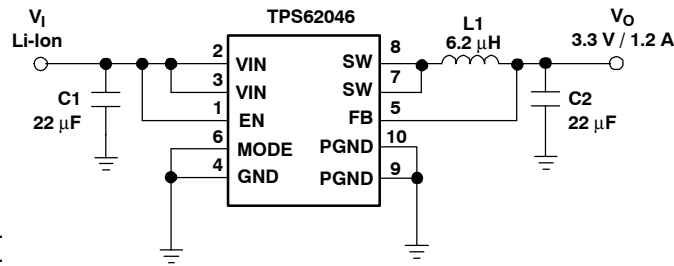

Components:
 C1: Taiyo Yuden JMK316BJ226ML
 C2: Taiyo Yuden JMK316BJ226ML
 L1: Sumida CDRH5D28-6R2

Figure 17. Li-Ion to 3.3 V/1.2 A Conversion

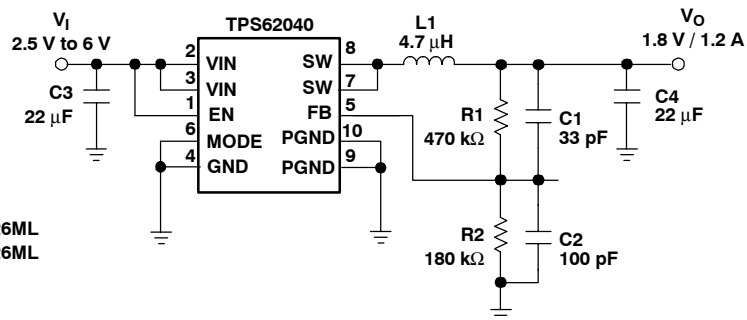

Components:
 C1: Taiyo Yuden JMK316BJ226ML
 C2: Taiyo Yuden JMK316BJ226ML
 L1: Sumida CDRH4D28C-4R7

Figure 18. Li-Ion to 1.8 V/1.2 A Conversion Using the Adjustable Output Voltage Version

PACKAGING INFORMATION

Orderable Device	Status ⁽¹⁾	Package Type	Package Drawing	Pins	Package Qty	Eco Plan ⁽²⁾	Lead/Ball Finish	MSL Peak Temp ⁽³⁾
TPS62040DGQ	ACTIVE	MSOP-Power PAD	DGQ	10	80	Green (RoHS & no Sb/Br)	CU NIPDAU	Level-1-260C-UNLIM
TPS62040DGQG4	ACTIVE	MSOP-Power PAD	DGQ	10	80	Green (RoHS & no Sb/Br)	CU NIPDAU	Level-1-260C-UNLIM
TPS62040DGQR	ACTIVE	MSOP-Power PAD	DGQ	10	2500	Green (RoHS & no Sb/Br)	CU NIPDAU	Level-1-260C-UNLIM
TPS62040DGQRG4	ACTIVE	MSOP-Power PAD	DGQ	10	2500	Green (RoHS & no Sb/Br)	CU NIPDAU	Level-1-260C-UNLIM
TPS62040DRCR	ACTIVE	SON	DRC	10	3000	Green (RoHS & no Sb/Br)	CU NIPDAU	Level-2-260C-1 YEAR
TPS62040DRCRG4	ACTIVE	SON	DRC	10	3000	Green (RoHS & no Sb/Br)	CU NIPDAU	Level-2-260C-1 YEAR
TPS62042DGQ	ACTIVE	MSOP-Power PAD	DGQ	10	80	Green (RoHS & no Sb/Br)	CU NIPDAU	Level-1-260C-UNLIM
TPS62042DGQG4	ACTIVE	MSOP-Power PAD	DGQ	10	80	Green (RoHS & no Sb/Br)	CU NIPDAU	Level-1-260C-UNLIM
TPS62042DGQR	ACTIVE	MSOP-Power PAD	DGQ	10	2500	Green (RoHS & no Sb/Br)	CU NIPDAU	Level-1-260C-UNLIM
TPS62042DGQRG4	ACTIVE	MSOP-Power PAD	DGQ	10	2500	Green (RoHS & no Sb/Br)	CU NIPDAU	Level-1-260C-UNLIM
TPS62042DRCR	ACTIVE	SON	DRC	10	3000	Green (RoHS & no Sb/Br)	CU NIPDAU	Level-2-260C-1 YEAR
TPS62042DRCRG4	ACTIVE	SON	DRC	10	3000	Green (RoHS & no Sb/Br)	CU NIPDAU	Level-2-260C-1 YEAR
TPS62043DGQ	ACTIVE	MSOP-Power PAD	DGQ	10	80	Green (RoHS & no Sb/Br)	CU NIPDAU	Level-1-260C-UNLIM
TPS62043DGQG4	ACTIVE	MSOP-Power PAD	DGQ	10	80	Green (RoHS & no Sb/Br)	CU NIPDAU	Level-1-260C-UNLIM
TPS62043DGQR	ACTIVE	MSOP-Power PAD	DGQ	10	2500	Green (RoHS & no Sb/Br)	CU NIPDAU	Level-1-260C-UNLIM
TPS62043DGQRG4	ACTIVE	MSOP-Power PAD	DGQ	10	2500	Green (RoHS & no Sb/Br)	CU NIPDAU	Level-1-260C-UNLIM
TPS62043DRCR	ACTIVE	SON	DRC	10	3000	Green (RoHS & no Sb/Br)	CU NIPDAU	Level-2-260C-1 YEAR
TPS62043DRCRG4	ACTIVE	SON	DRC	10	3000	Green (RoHS & no Sb/Br)	CU NIPDAU	Level-2-260C-1 YEAR
TPS62044DGQ	ACTIVE	MSOP-Power PAD	DGQ	10	80	Green (RoHS & no Sb/Br)	CU NIPDAU	Level-1-260C-UNLIM
TPS62044DGQG4	ACTIVE	MSOP-	DGQ	10	80	Green (RoHS & no Sb/Br)	CU NIPDAU	Level-1-260C-UNLIM

Orderable Device	Status ⁽¹⁾	Package Type	Package Drawing	Pins	Package Qty	Eco Plan ⁽²⁾	Lead/Ball Finish	MSL Peak Temp ⁽³⁾
		Power PAD				no Sb/Br)		
TPS62044DGQR	ACTIVE	MSOP-Power PAD	DGQ	10	2500	Green (RoHS & no Sb/Br)	CU NIPDAU	Level-1-260C-UNLIM
TPS62044DGQRG4	ACTIVE	MSOP-Power PAD	DGQ	10	2500	Green (RoHS & no Sb/Br)	CU NIPDAU	Level-1-260C-UNLIM
TPS62044DRCR	ACTIVE	SON	DRC	10	3000	Green (RoHS & no Sb/Br)	CU NIPDAU	Level-2-260C-1 YEAR
TPS62044DRCRG4	ACTIVE	SON	DRC	10	3000	Green (RoHS & no Sb/Br)	CU NIPDAU	Level-2-260C-1 YEAR
TPS62046DGQ	ACTIVE	MSOP-Power PAD	DGQ	10	80	Green (RoHS & no Sb/Br)	CU NIPDAU	Level-1-260C-UNLIM
TPS62046DGQG4	ACTIVE	MSOP-Power PAD	DGQ	10	80	Green (RoHS & no Sb/Br)	CU NIPDAU	Level-1-260C-UNLIM
TPS62046DGQR	ACTIVE	MSOP-Power PAD	DGQ	10	2500	Green (RoHS & no Sb/Br)	CU NIPDAU	Level-1-260C-UNLIM
TPS62046DGQRG4	ACTIVE	MSOP-Power PAD	DGQ	10	2500	Green (RoHS & no Sb/Br)	CU NIPDAU	Level-1-260C-UNLIM
TPS62046DRCR	ACTIVE	SON	DRC	10	3000	Green (RoHS & no Sb/Br)	CU NIPDAU	Level-2-260C-1 YEAR
TPS62046DRCRG4	ACTIVE	SON	DRC	10	3000	Green (RoHS & no Sb/Br)	CU NIPDAU	Level-2-260C-1 YEAR

⁽¹⁾ The marketing status values are defined as follows:

ACTIVE: Product device recommended for new designs.

LIFEBUY: TI has announced that the device will be discontinued, and a lifetime-buy period is in effect.

NRND: Not recommended for new designs. Device is in production to support existing customers, but TI does not recommend using this part in a new design.

PREVIEW: Device has been announced but is not in production. Samples may or may not be available.

OBSOLETE: TI has discontinued the production of the device.

⁽²⁾ Eco Plan - The planned eco-friendly classification: Pb-Free (RoHS), Pb-Free (RoHS Exempt), or Green (RoHS & no Sb/Br) - please check <http://www.ti.com/productcontent> for the latest availability information and additional product content details.

TBD: The Pb-Free/Green conversion plan has not been defined.

Pb-Free (RoHS): TI's terms "Lead-Free" or "Pb-Free" mean semiconductor products that are compatible with the current RoHS requirements for all 6 substances, including the requirement that lead not exceed 0.1% by weight in homogeneous materials. Where designed to be soldered at high temperatures, TI Pb-Free products are suitable for use in specified lead-free processes.

Pb-Free (RoHS Exempt): This component has a RoHS exemption for either 1) lead-based flip-chip solder bumps used between the die and package, or 2) lead-based die adhesive used between the die and leadframe. The component is otherwise considered Pb-Free (RoHS compatible) as defined above.

Green (RoHS & no Sb/Br): TI defines "Green" to mean Pb-Free (RoHS compatible), and free of Bromine (Br) and Antimony (Sb) based flame retardants (Br or Sb do not exceed 0.1% by weight in homogeneous material)

⁽³⁾ MSL, Peak Temp. -- The Moisture Sensitivity Level rating according to the JEDEC industry standard classifications, and peak solder temperature.

Important Information and Disclaimer: The information provided on this page represents TI's knowledge and belief as of the date that it is provided. TI bases its knowledge and belief on information provided by third parties, and makes no representation or warranty as to the accuracy of such information. Efforts are underway to better integrate information from third parties. TI has taken and continues to take reasonable steps to provide representative and accurate information but may not have conducted destructive testing or chemical analysis on incoming materials and chemicals. TI and TI suppliers consider certain information to be proprietary, and thus CAS numbers and other limited

information may not be available for release.

In no event shall TI's liability arising out of such information exceed the total purchase price of the TI part(s) at issue in this document sold by TI to Customer on an annual basis.

TAPE AND REEL INFORMATION



QUADRANT ASSIGNMENTS FOR PIN 1 ORIENTATION IN TAPE

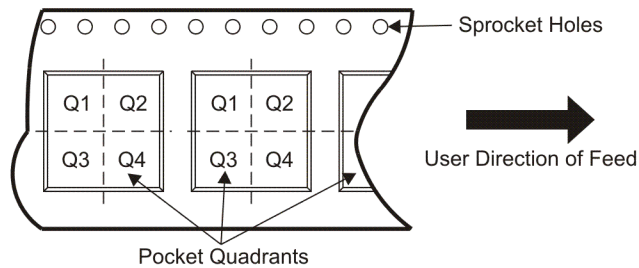

*All dimensions are nominal

Device	Package Type	Package Drawing	Pins	SPQ	Reel Diameter (mm)	Reel Width W1 (mm)	A0 (mm)	B0 (mm)	K0 (mm)	P1 (mm)	W (mm)	Pin1 Quadrant
TPS62040DGQR	MSOP-Power PAD	DGQ	10	2500	330.0	12.0	5.0	3.0	1.0	8.0	12.0	Q1
TPS62040DRCR	SON	DRC	10	3000	330.0	12.0	3.0	3.0	1.0	8.0	12.0	Q2
TPS62040DRCR	SON	DRC	10	3000	330.0	12.0	3.0	3.0	1.0	8.0	12.0	Q2
TPS62042DGQR	MSOP-Power PAD	DGQ	10	2500	330.0	12.0	5.0	3.0	1.0	8.0	12.0	Q1
TPS62042DRCR	SON	DRC	10	3000	330.0	12.0	3.0	3.0	1.0	8.0	12.0	Q2
TPS62043DGQR	MSOP-Power PAD	DGQ	10	2500	330.0	12.0	5.0	3.0	1.0	8.0	12.0	Q1
TPS62043DRCR	SON	DRC	10	3000	330.0	12.0	3.0	3.0	1.0	8.0	12.0	Q2
TPS62044DGQR	MSOP-Power PAD	DGQ	10	2500	330.0	12.0	5.0	3.0	1.0	8.0	12.0	Q1
TPS62044DRCR	SON	DRC	10	3000	330.0	12.0	3.0	3.0	1.0	8.0	12.0	Q2
TPS62046DGQR	MSOP-Power PAD	DGQ	10	2500	330.0	12.0	5.0	3.0	1.0	8.0	12.0	Q1
TPS62046DRCR	SON	DRC	10	3000	330.0	12.0	3.0	3.0	1.0	8.0	12.0	Q2

Device	Package Type	Package Drawing	Pins	SPQ	Reel Diameter (mm)	Reel Width W1 (mm)	A0 (mm)	B0 (mm)	K0 (mm)	P1 (mm)	W (mm)	Pin1 Quadrant
TPS62046DRCR	SON	DRC	10	3000	330.0	12.0	3.0	3.0	1.0	8.0	12.0	Q2

TAPE AND REEL BOX DIMENSIONS

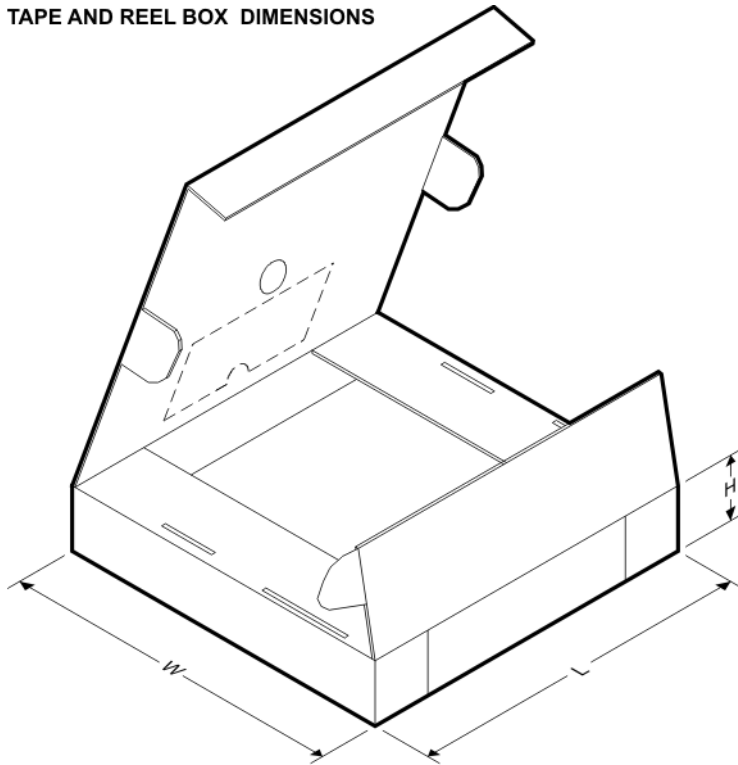

*All dimensions are nominal

Device	Package Type	Package Drawing	Pins	SPQ	Length (mm)	Width (mm)	Height (mm)
TPS62040DGQR	MSOP-PowerPAD	DGQ	10	2500	346.0	346.0	29.0
TPS62040DRCR	SON	DRC	10	3000	346.0	346.0	29.0
TPS62040DRCR	SON	DRC	10	3000	370.0	355.0	55.0
TPS62042DGQR	MSOP-PowerPAD	DGQ	10	2500	346.0	346.0	29.0
TPS62042DRCR	SON	DRC	10	3000	346.0	346.0	29.0
TPS62043DGQR	MSOP-PowerPAD	DGQ	10	2500	346.0	346.0	29.0
TPS62043DRCR	SON	DRC	10	3000	346.0	346.0	29.0
TPS62044DGQR	MSOP-PowerPAD	DGQ	10	2500	346.0	346.0	29.0
TPS62044DRCR	SON	DRC	10	3000	346.0	346.0	29.0
TPS62046DGQR	MSOP-PowerPAD	DGQ	10	2500	346.0	346.0	29.0
TPS62046DRCR	SON	DRC	10	3000	346.0	346.0	29.0
TPS62046DRCR	SON	DRC	10	3000	370.0	355.0	55.0

DGQ (S-PDSO-G10)

PowerPAD™ PLASTIC SMALL-OUTLINE PACKAGE

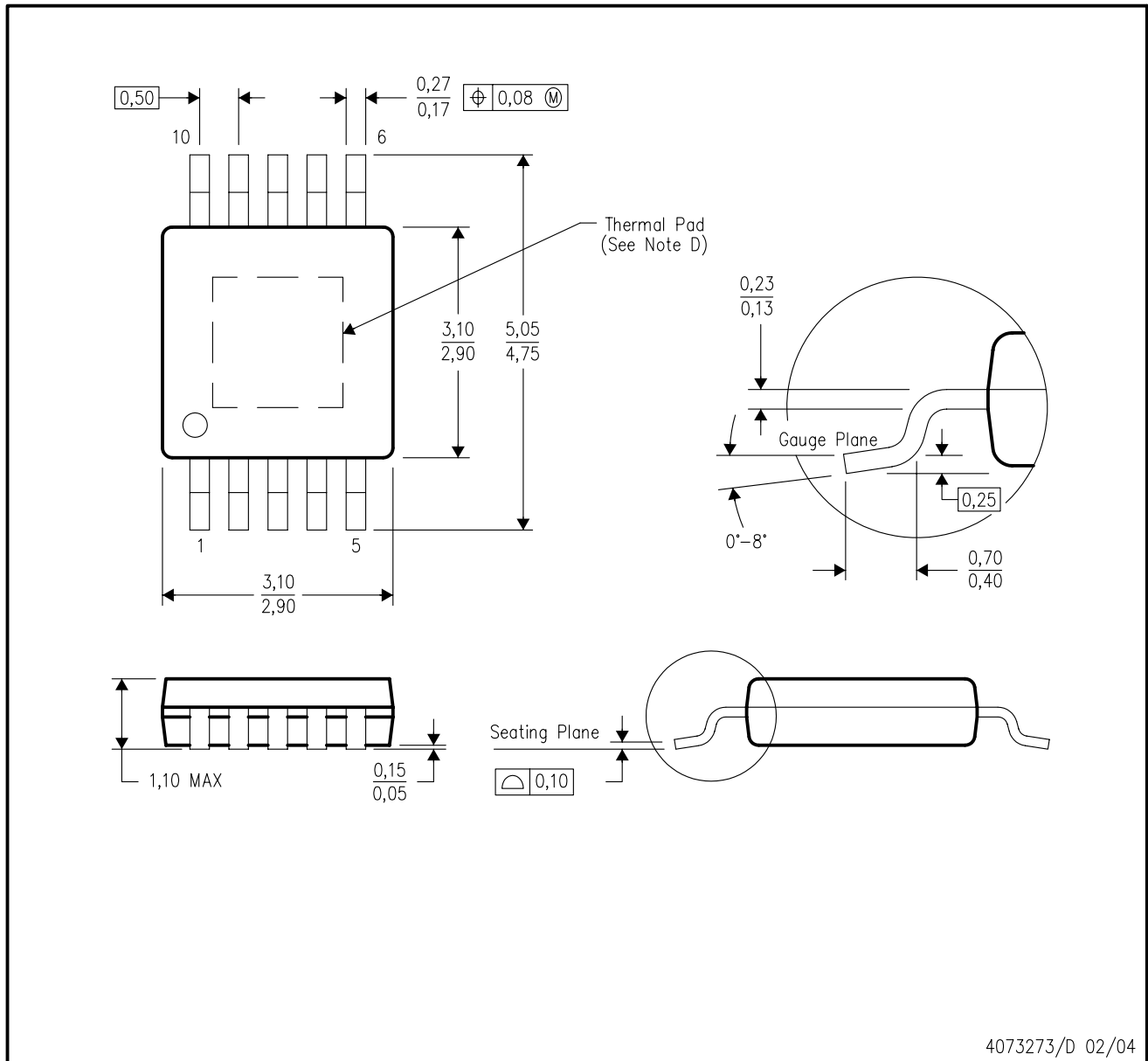

- NOTES:
- A. All linear dimensions are in millimeters.
 - B. This drawing is subject to change without notice.
 - C. Body dimensions do not include mold flash or protrusion.
 - D. This package is designed to be soldered to a thermal pad on the board. Refer to Technical Brief, PowerPAD Thermally Enhanced Package, Texas Instruments Literature No. SLMA002 for information regarding recommended board layout. This document is available at www.ti.com <<http://www.ti.com>>.
 - E. Falls within JEDEC MO-187 variation BA-T.

PowerPAD is a trademark of Texas Instruments.

THERMAL INFORMATION

This PowerPAD™ package incorporates an exposed thermal pad that is designed to be attached directly to an external heatsink. The thermal pad must be soldered directly to the printed circuit board (PCB). After soldering, the PCB can be used as a heatsink. In addition, through the use of thermal vias, the thermal pad can be attached directly to the appropriate copper plane shown in the electrical schematic for the device, or alternatively, can be attached to a special heatsink structure designed into the PCB. This design optimizes the heat transfer from the integrated circuit (IC).

For additional information on the PowerPAD package and how to take advantage of its heat dissipating abilities, refer to Technical Brief, PowerPAD Thermally Enhanced Package, Texas Instruments Literature No. SLMA002 and Application Brief, PowerPAD Made Easy, Texas Instruments Literature No. SLMA004. Both documents are available at www.ti.com.

The exposed thermal pad dimensions for this package are shown in the following illustration.

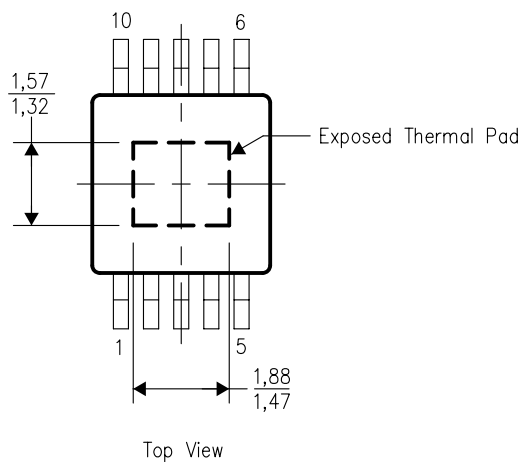

NOTE: All linear dimensions are in millimeters

Exposed Thermal Pad Dimensions

DGQ (R-PDSO-G10) PowerPAD™

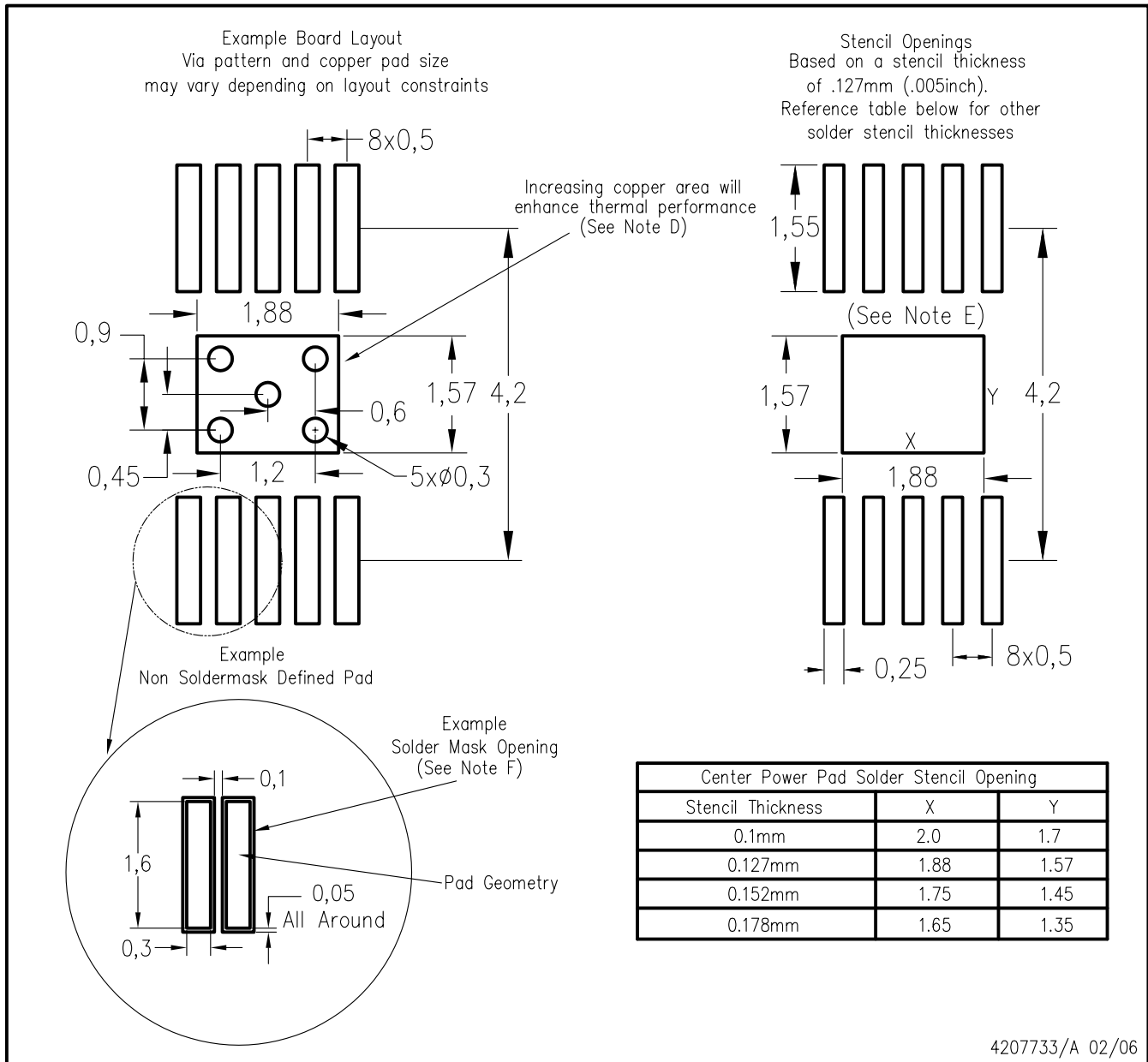

- NOTES:
- A. All linear dimensions are in millimeters.
 - B. This drawing is subject to change without notice.
 - C. Customers should place a note on the circuit board fabrication drawing not to alter the center solder mask defined pad.
 - D. This package is designed to be soldered to a thermal pad on the board. Refer to Technical Brief, PowerPad Thermally Enhanced Package, Texas Instruments Literature No. SLMA002, SLMA004, and also the Product Data Sheets for specific thermal information, via requirements, and recommended board layout. These documents are available at www.ti.com <<http://www.ti.com>>. Publication IPC-7351 is recommended for alternate designs.
 - E. Laser cutting apertures with trapezoidal walls and also rounding corners will offer better paste release. Customers should contact their board assembly site for stencil design recommendations. Example stencil design based on a 50% volumetric metal load solder paste. Refer to IPC-7525 for other stencil recommendations.
 - F. Customers should contact their board fabrication site for solder mask tolerances between and around signal pads.

DRC (S-PDSO-N10)

PLASTIC SMALL OUTLINE

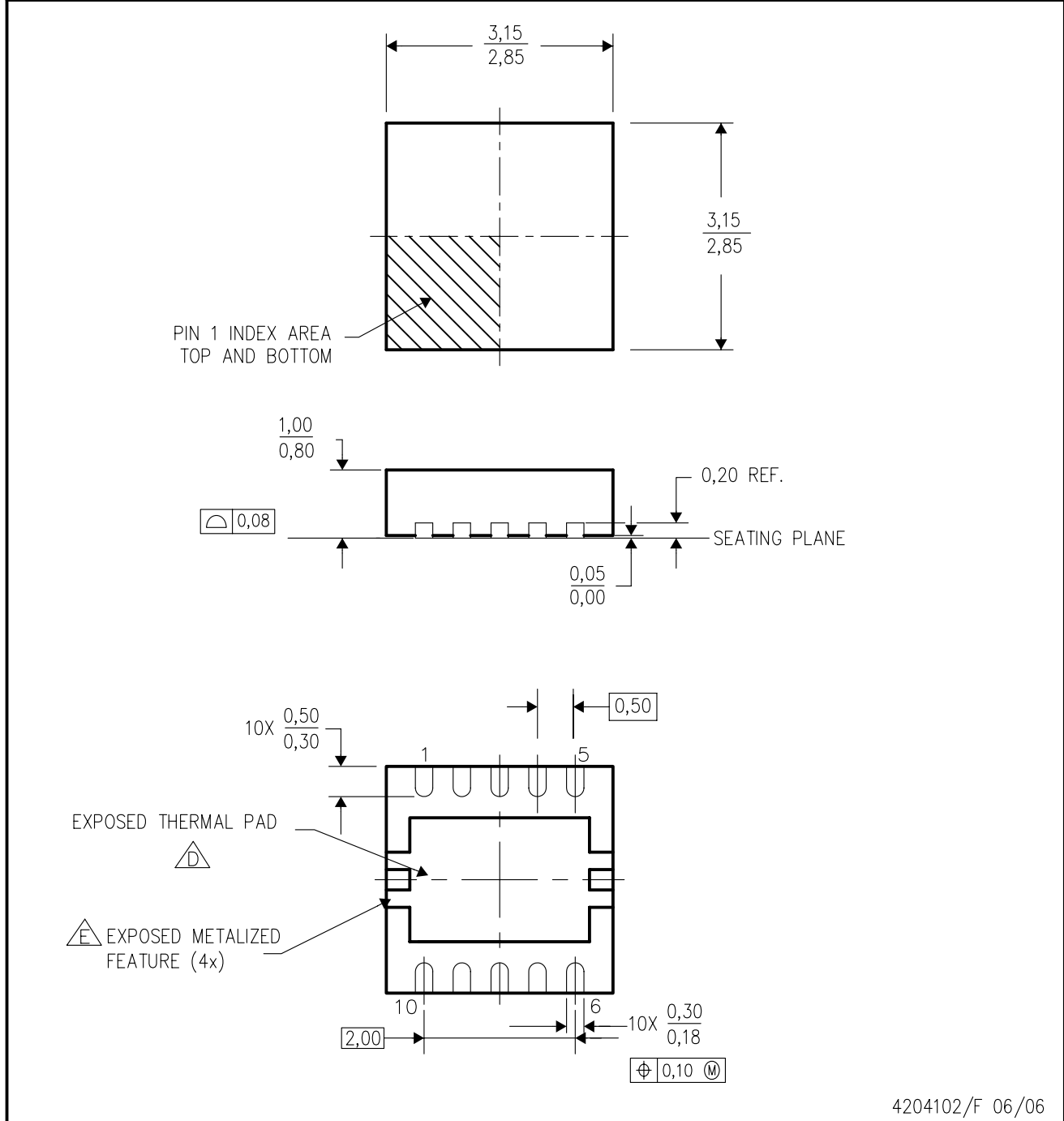

4204102/F 06/06

- NOTES: A. All linear dimensions are in millimeters. Dimensioning and tolerancing per ASME Y14.5M-1994.
 B. This drawing is subject to change without notice.
 C. Small Outline No-Lead (SON) package configuration.
 D. The package thermal pad must be soldered to the board for thermal and mechanical performance. See the Product Data Sheet for details regarding the exposed thermal pad dimensions.
 E. Metalized features are supplier options and may not be on the package.

THERMAL INFORMATION

This package incorporates an exposed thermal pad that is designed to be attached directly to an external heatsink. The thermal pad must be soldered directly to the printed circuit board (PCB). After soldering, the PCB can be used as a heatsink. In addition, through the use of thermal vias, the thermal pad can be attached directly to the appropriate copper plane shown in the electrical schematic for the device, or alternatively, can be attached to a special heatsink structure designed into the PCB. This design optimizes the heat transfer from the integrated circuit (IC).

For information on the Quad Flatpack No-Lead (QFN) package and its advantages, refer to Application Report, Quad Flatpack No-Lead Logic Packages, Texas Instruments Literature No. SCBA017. This document is available at www.ti.com.

The exposed thermal pad dimensions for this package are shown in the following illustration.

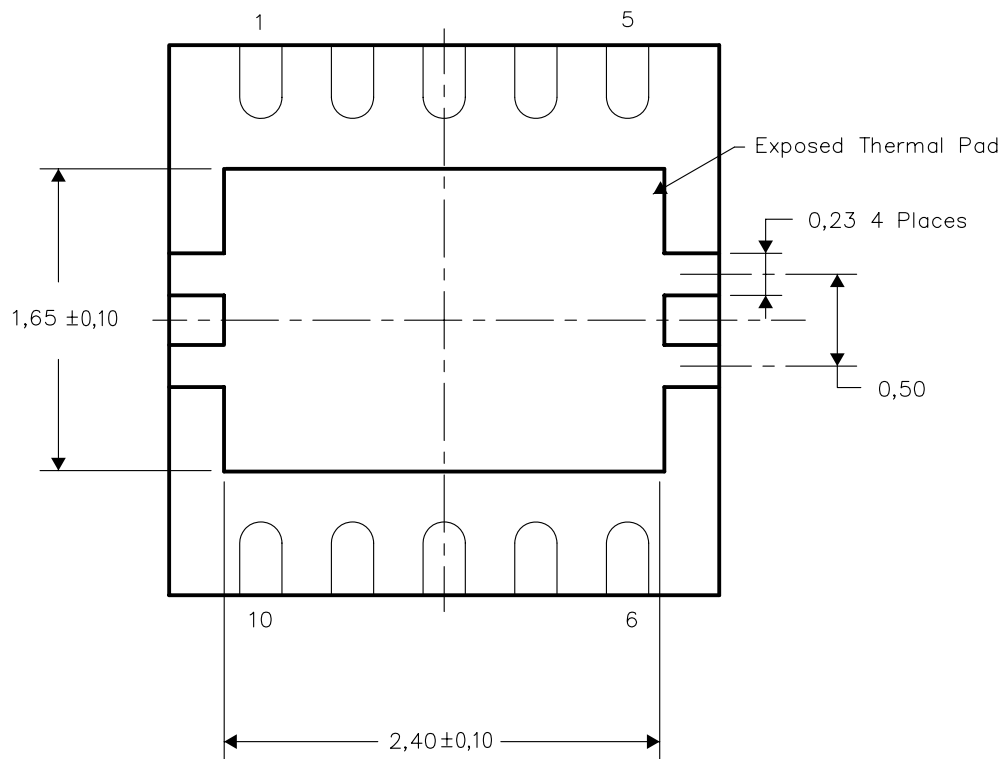

Bottom View

NOTE: All linear dimensions are in millimeters

Exposed Thermal Pad Dimensions

DRC (S-PDSO-N10)

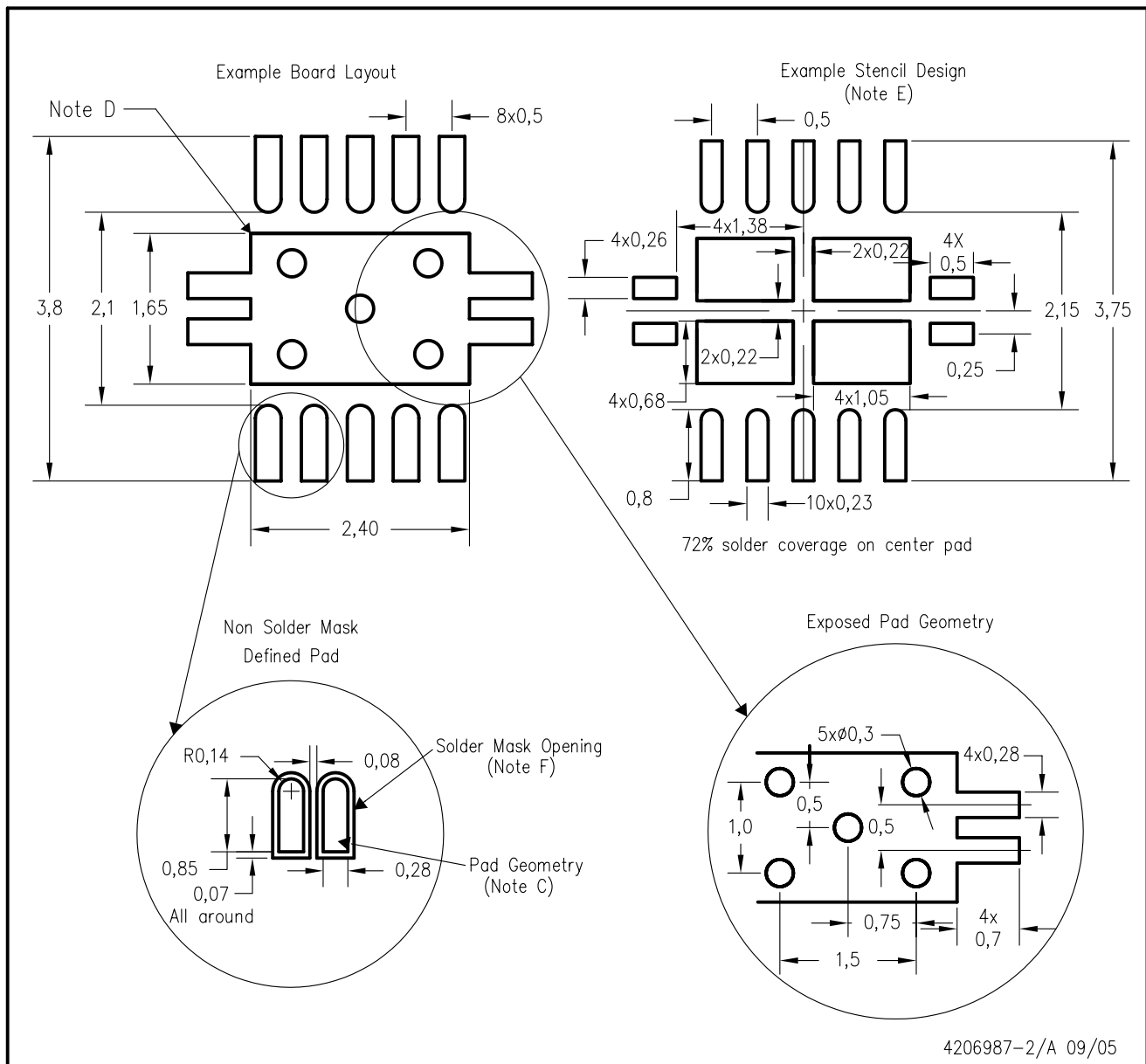

- NOTES:
- A. All linear dimensions are in millimeters.
 - B. This drawing is subject to change without notice.
 - C. Publication IPC-7351 is recommended for alternate designs.
 - D. This package is designed to be soldered to a thermal pad on the board. Refer to Application Note, Quad Flat-Pack Packages, Texas Instruments Literature No. SCBA017, SLUA271, and also the Product Data Sheets for specific thermal information, via requirements, and recommended board layout. These documents are available at www.ti.com <<http://www.ti.com>>.
 - E. Laser cutting apertures with trapezoidal walls and also rounding corners will offer better paste release. Customers should contact their board assembly site for stencil design recommendations. Refer to IPC 7525 for stencil design considerations.
 - F. Customers should contact their board fabrication site for minimum solder mask web tolerances between signal pads.

IMPORTANT NOTICE

Texas Instruments Incorporated and its subsidiaries (TI) reserve the right to make corrections, modifications, enhancements, improvements, and other changes to its products and services at any time and to discontinue any product or service without notice. Customers should obtain the latest relevant information before placing orders and should verify that such information is current and complete. All products are sold subject to TI's terms and conditions of sale supplied at the time of order acknowledgment.

TI warrants performance of its hardware products to the specifications applicable at the time of sale in accordance with TI's standard warranty. Testing and other quality control techniques are used to the extent TI deems necessary to support this warranty. Except where mandated by government requirements, testing of all parameters of each product is not necessarily performed.

TI assumes no liability for applications assistance or customer product design. Customers are responsible for their products and applications using TI components. To minimize the risks associated with customer products and applications, customers should provide adequate design and operating safeguards.

TI does not warrant or represent that any license, either express or implied, is granted under any TI patent right, copyright, mask work right, or other TI intellectual property right relating to any combination, machine, or process in which TI products or services are used. Information published by TI regarding third-party products or services does not constitute a license from TI to use such products or services or a warranty or endorsement thereof. Use of such information may require a license from a third party under the patents or other intellectual property of the third party, or a license from TI under the patents or other intellectual property of TI.

Reproduction of TI information in TI data books or data sheets is permissible only if reproduction is without alteration and is accompanied by all associated warranties, conditions, limitations, and notices. Reproduction of this information with alteration is an unfair and deceptive business practice. TI is not responsible or liable for such altered documentation. Information of third parties may be subject to additional restrictions.

Resale of TI products or services with statements different from or beyond the parameters stated by TI for that product or service voids all express and any implied warranties for the associated TI product or service and is an unfair and deceptive business practice. TI is not responsible or liable for any such statements.

TI products are not authorized for use in safety-critical applications (such as life support) where a failure of the TI product would reasonably be expected to cause severe personal injury or death, unless officers of the parties have executed an agreement specifically governing such use. Buyers represent that they have all necessary expertise in the safety and regulatory ramifications of their applications, and acknowledge and agree that they are solely responsible for all legal, regulatory and safety-related requirements concerning their products and any use of TI products in such safety-critical applications, notwithstanding any applications-related information or support that may be provided by TI. Further, Buyers must fully indemnify TI and its representatives against any damages arising out of the use of TI products in such safety-critical applications.

TI products are neither designed nor intended for use in military/aerospace applications or environments unless the TI products are specifically designated by TI as military-grade or "enhanced plastic." Only products designated by TI as military-grade meet military specifications. Buyers acknowledge and agree that any such use of TI products which TI has not designated as military-grade is solely at the Buyer's risk, and that they are solely responsible for compliance with all legal and regulatory requirements in connection with such use.

TI products are neither designed nor intended for use in automotive applications or environments unless the specific TI products are designated by TI as compliant with ISO/TS 16949 requirements. Buyers acknowledge and agree that, if they use any non-designated products in automotive applications, TI will not be responsible for any failure to meet such requirements.

Following are URLs where you can obtain information on other Texas Instruments products and application solutions:

Products

Amplifiers	amplifier.ti.com
Data Converters	dataconverter.ti.com
DSP	dsp.ti.com
Clocks and Timers	www.ti.com/clocks
Interface	interface.ti.com
Logic	logic.ti.com
Power Mgmt	power.ti.com
Microcontrollers	microcontroller.ti.com
RFID	www.ti-rfid.com
RF/IF and ZigBee® Solutions	www.ti.com/lprf

Applications

Audio	www.ti.com/audio
Automotive	www.ti.com/automotive
Broadband	www.ti.com/broadband
Digital Control	www.ti.com/digitalcontrol
Medical	www.ti.com/medical
Military	www.ti.com/military
Optical Networking	www.ti.com/opticalnetwork
Security	www.ti.com/security
Telephony	www.ti.com/telephony
Video & Imaging	www.ti.com/video
Wireless	www.ti.com/wireless

Mailing Address: Texas Instruments, Post Office Box 655303, Dallas, Texas 75265
Copyright © 2008, Texas Instruments Incorporated