

## FEATURES

- 1.5-V, 1.8-V, 2.5-V, 3.3-V, 5-V, and Adjustable-Output Voltage Options
- Output Current of 800 mA
- Specified Dropout Voltage at Multiple Current Levels
- 0.2% Line Regulation Maximum
- 0.4% Load Regulation Maximum

DCY (SOT-223) PACKAGE  
(TOP VIEW)

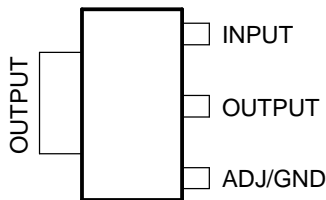

DRJ (QFN) PACKAGE  
(TOP VIEW)

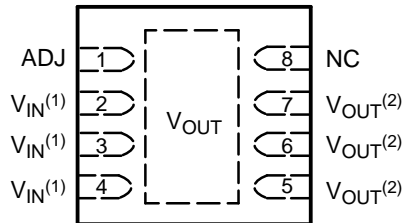

(1)  $V_{IN}$  pins (2, 3, 4) must be connected together.  
(2)  $V_{OUT}$  pins (5, 6, 7) must be connected together.

KCS (TO-220) PACKAGE  
(TOP VIEW)

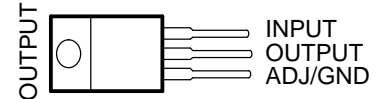

KTE (PowerFLEX™) PACKAGE  
(TOP VIEW)

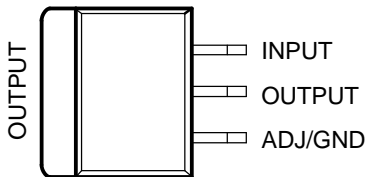

KTP (PowerFLEX™/TO-252) PACKAGE  
(TOP VIEW)

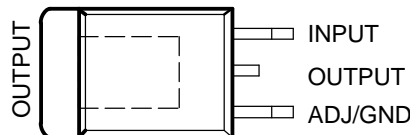

KVU (TO-252) PACKAGE  
(TOP VIEW)

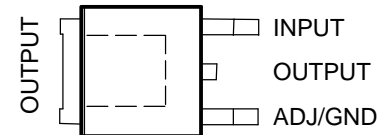

## DESCRIPTION/ORDERING INFORMATION

The TLV1117 is a positive low-dropout voltage regulator designed to provide up to 800 mA of output current. The device is available in 1.5-V, 1.8-V, 2.5-V, 3.3-V, 5-V, and adjustable-output voltage options. All internal circuitry is designed to operate down to 1-V input-to-output differential. Dropout voltage is specified at a maximum of 1.3 V at 800 mA, decreasing at lower load currents.

The low-profile surface-mount KTP package allows the device to be used in applications where space is limited. The TLV1117 is designed to be stable with tantalum and aluminum electrolytic output capacitors having an ESR between 0.2  $\Omega$  and 10  $\Omega$ .

Unlike pnp-type regulators, in which up to 10% of the output current is wasted as quiescent current, the quiescent current of the TLV1117 flows into the load, increasing efficiency.

The TLV1117C device is characterized for operation over the virtual junction temperature range of 0°C to 125°C, and the TLV1117I device is characterized for operation over the virtual junction temperature range of -40°C to 125°C.



Please be aware that an important notice concerning availability, standard warranty, and use in critical applications of Texas Instruments semiconductor products and disclaimers thereto appears at the end of this data sheet.

PowerFLEX, PowerPAD are trademarks of Texas Instruments.

# TLV1117 ADJUSTABLE AND FIXED LOW-DROPOUT VOLTAGE REGULATOR

SLVS561G–DECEMBER 2004–REVISED APRIL 2006

## TLV1117C ORDERING INFORMATION

T <sub>A</sub>	V <sub>O</sub> TYP	PACKAGE <sup>(1)</sup>		ORDERABLE PART NUMBER	TOP-SIDE MARKING
0°C to 125°C	1.5 V	QFN – DRJ	Reel of 1000	TLV1117-15CDRJR	ZYH
		SOT-223 – DCY	Tube of 80	TLV1117-15CDCY	T2
			Reel of 2500	TLV1117-15CDCYR	
	TO-252 – KVU	Reel of 2500	TLV1117-15CKVUR	ZE15	
	1.8 V	QFN – DRJ	Reel of 1000	TLV1117-18CDRJR	ZYK
		SOT-223 – DCY	Tube of 80	TLV1117-18CDCY	T4
			Reel of 2500	TLV1117-18CDCYR	
	TO-252 – KVU	Reel of 2500	TLV1117-18CKVUR	ZE18	
	2.5 V	QFN – DRJ	Reel of 1000	TLV1117-25CDRJR	ZYM
		SOT-223 – DCY	Tube of 80	TLV1117-25CDCY	T6
			Reel of 2500	TLV1117-25CDCYR	
	TO-252 – KVU	Reel of 2500	TLV1117-25CKVUR	ZE25	
	3.3 V	QFN – DRJ	Reel of 1000	TLV1117-33CDRJR	ZYP
		SOT-223 – DCY	Tube of 80	TLV1117-33CDCY	V3
			Reel of 2500	TLV1117-33CDCYR	
	TO-252 – KVU	Reel of 2500	TLV1117-33CKVUR	ZE33	
	5 V	QFN – DRJ	Reel of 1000	TLV1117-50CDRJR	ZE50
		SOT-223 – DCY	Tube of 80	TLV1117-50CDCY	VT
			Reel of 2500	TLV1117-50CDCYR	
	TO-252 – KVU	Reel of 2500	TLV1117-50CKVUR	ZE50	
	ADJ	PowerFLEX™– KTE	Reel of 2000	TLV1117CKTER	TLV1117C
PowerFLEX/TO-252 <sup>(2)</sup> – KTP		Reel of 2000	TLV1117CKTPR	TV1117	
QFN – DRJ		Reel of 1000	TLV1117CDRJR	ZYS	
SOT-223 – DCY		Tube of 80	TLV1117CDCY	V4	
		Reel of 2500	TLV1117CDCYR		
TO-220 – KCS		Tube of 50	TLV1117CKCS	TLV1117C	
TO-252 – KVU	Reel of 2500	TLV1117CKVUR	TV1117		

(1) Package drawings, standard packing quantities, thermal data, symbolization, and PCB design guidelines are available at [www.ti.com/sc/package](http://www.ti.com/sc/package).

(2) Complies with TO-252, variation AC

### TLV1117I ORDERING INFORMATION

T <sub>A</sub>	V <sub>O</sub> TYP	PACKAGE <sup>(1)</sup>		ORDERABLE PART NUMBER	TOP-SIDE MARKING
–40°C to 125°C	1.5 V	QFN – DRJ	Reel of 1000	TLV1117-15IDRJR	ZYJ
		SOT-223 – DCY	Tube of 80	TLV1117-15IDCY	T3
			Reel of 2500	TLV1117-15IDCYR	
	TO-252 – KVU	Reel of 2500	TLV1117-15IKVUR	ZF15	
	1.8 V	QFN – DRJ	Reel of 1000	TLV1117-18IDRJR	ZYL
		SOT-223 – DCY	Tube of 80	TLV1117-18IDCY	T5
			Reel of 2500	TLV1117-18IDCYR	
	TO-252 – KVU	Reel of 2500	TLV1117-18IKVUR	ZF18	
	2.5 V	QFN – DRJ	Reel of 1000	TLV1117-25IDRJR	ZYN
		SOT-223 – DCY	Tube of 80	TLV1117-25IDCY	T8
			Reel of 2500	TLV1117-25IDCYR	
	TO-252 – KVU	Reel of 2500	TLV1117-25IKVUR	ZF25	
	3.3 V	QFN – DRJ	Reel of 1000	TLV1117-33IDRJR	ZYR
		SOT-223 – DCY	Tube of 80	TLV1117-33IDCY	VS
			Reel of 2500	TLV1117-33IDCYR	
	TO-252 – KVU	Reel of 2500	TLV1117-33IKVUR	ZF33	
	5 V	QFN – DRJ	Reel of 1000	TLV1117-50IDRJR	ZF50
		SOT-223 – DCY	Tube of 80	TLV1117-50IDCY	VU
			Reel of 2500	TLV1117-50IDCYR	
	TO-252 – KVU	Reel of 2500	TLV1117-50IKVUR	ZF50	
	ADJ	PowerFLEX – KTE	Reel of 2000	TLV1117IKTER	TLV1117I
PowerFLEX/TO-252 <sup>(2)</sup> – KTP		Reel of 2000	TLV1117IKTPR	TY1117	
QFN – DRJ		Reel of 1000	TLV1117IDRJR	ZYT	
SOT-223 – DCY		Tube of 80	TLV1117IDCY	V2	
		Reel of 2500	TLV1117IDCYR		
TO-220 – KCS		Tube of 50	TLV1117IKCS	TLV1117I	
TO-252 – KVU	Reel of 2500	TLV1117IKVUR	TY1117		

(1) Package drawings, standard packing quantities, thermal data, symbolization, and PCB design guidelines are available at [www.ti.com/sc/package](http://www.ti.com/sc/package).

(2) Complies with TO-252, variation AC



### Absolute Maximum Ratings<sup>(1)</sup>

over operating free-air temperature range (unless otherwise noted)

		MIN	MAX	UNIT
V <sub>I</sub>	Continuous input voltage		16	V
T <sub>J</sub>	Operating virtual-junction temperature		150	°C
T <sub>stg</sub>	Storage temperature range	–65	150	°C

(1) Stresses beyond those listed under "absolute maximum ratings" may cause permanent damage to the device. These are stress ratings only, and functional operation of the device at these or any other conditions beyond those indicated under "recommended operating conditions" is not implied. Exposure to absolute-maximum-rated conditions for extended periods may affect device reliability.

### Package Thermal Data<sup>(1)</sup>

PACKAGE	BOARD	θ <sub>JP</sub> <sup>(2)</sup>	θ <sub>JC</sub>	θ <sub>JA</sub>
PowerFLEX (KTE)	High K, JESD 51-5	2.7°C/W	11.6°C/W	23.3°C/W
PowerFLEX/TO-252 (KTP)	High K, JESD 51-5	1.4°C/W	19.2°C/W	27.6°C/W
QFN (DRJ)	High K, JESD 51-5	1.78°C/W		46.5°C/W
SOT-223 (DCY)	High K, JESD 51-7		30.6°C/W	52.8°C/W
TO-252 (KVU)	High K, JESD 51-5	TBD		30.3°C/W
TO-220 (KCS)	High K, JESD 51-5	3°C/W	17°C/W	19°C/W

- (1) Maximum power dissipation is a function of T<sub>J(max)</sub>, θ<sub>JA</sub>, and T<sub>A</sub>. The maximum allowable power dissipation at any allowable ambient temperature is P<sub>D</sub> = (T<sub>J(max)</sub> – T<sub>A</sub>)/θ<sub>JA</sub>. Operating at the absolute maximum T<sub>J</sub> of 150°C can affect reliability.
- (2) For packages with exposed thermal pads, such as QFN, PowerPAD™, and PowerFLEX, θ<sub>JP</sub> is defined as the thermal resistance between the die junction and the bottom of the exposed pad.

### Recommended Operating Conditions

		MIN <sup>(1)</sup>	MAX	UNIT	
V <sub>IN</sub>	Input voltage	TLV1117	2.7	15	V
		TLV1117-15	2.9	15	
		TLV1117-18	3.2	15	
		TLV1117-25	3.9	15	
		TLV1117-33	4.7	15	
		TLV1117-50	6.4	15	
I <sub>O</sub>	Output current		0.8	A	
T <sub>J</sub>	Operating virtual-junction temperature	TLV1117C	0	125	°C
		TLV1117I	–40	125	

(1) The input-to-output differential across the regulator should provide for some margin against regulator operation at the maximum dropout (for a particular current value). This margin is needed to account for tolerances in both the input voltage (lower limit) and the output voltage (upper limit). The absolute minimum V<sub>IN</sub> for a desired maximum output current can be calculated by the following:

$$V_{IN(min)} = V_{OUT(max)} + V_{DO(max @ \text{rated current})}$$

# TLV1117 ADJUSTABLE AND FIXED LOW-DROPOUT VOLTAGE REGULATOR

SLVS561G–DECEMBER 2004–REVISED APRIL 2006

## TLV1117C Electrical Characteristics

$T_J = 0^\circ\text{C}$  to  $125^\circ\text{C}$ , all typical values are at  $T_J = 25^\circ\text{C}$  (unless otherwise noted)

PARAMETER	TEST CONDITIONS <sup>(1)</sup>	MIN	TYP	MAX	UNIT	
Reference voltage, $V_{REF}$	$V_{IN} - V_{OUT} = 2\text{ V}$ , $I_{OUT} = 10\text{ mA}$ , $T_J = 25^\circ\text{C}$	1.238	1.25	1.262	V	
	$V_{IN} - V_{OUT} = 1.4\text{ V}$ to $10\text{ V}$ , $I_{OUT} = 10\text{ mA}$ to $800\text{ mA}$	1.225	1.25	1.27		
Output voltage, $V_{OUT}$	$V_{IN} = 3.5\text{ V}$ , $I_{OUT} = 10\text{ mA}$ , $T_J = 25^\circ\text{C}$	1.485	1.5	1.515		
	$V_{IN} = 2.9\text{ V}$ to $10\text{ V}$ , $I_{OUT} = 0$ to $800\text{ mA}$	1.455	1.5	1.545		
	$V_{IN} = 3.8\text{ V}$ , $I_{OUT} = 10\text{ mA}$ , $T_J = 25^\circ\text{C}$	1.782	1.8	1.818		
	$V_{IN} = 3.2\text{ V}$ to $10\text{ V}$ , $I_{OUT} = 0$ to $800\text{ mA}$	1.746	1.8	1.854		
	$V_{IN} = 4.5\text{ V}$ , $I_{OUT} = 10\text{ mA}$ , $T_J = 25^\circ\text{C}$	2.475	2.5	2.525		
	$V_{IN} = 3.9\text{ V}$ to $10\text{ V}$ , $I_{OUT} = 0$ to $800\text{ mA}$	2.450	2.5	2.550		
	$V_{IN} = 5\text{ V}$ , $I_{OUT} = 10\text{ mA}$ , $T_J = 25^\circ\text{C}$	3.267	3.3	3.333		
	$V_{IN} = 4.75\text{ V}$ to $10\text{ V}$ , $I_{OUT} = 0$ to $800\text{ mA}$	3.235	3.3	3.365		
	$V_{IN} = 7\text{ V}$ , $I_{OUT} = 10\text{ mA}$ , $T_J = 25^\circ\text{C}$	4.950	5.0	5.050		
	$V_{IN} = 6.5\text{ V}$ to $12\text{ V}$ , $I_{OUT} = 0$ to $800\text{ mA}$	4.900	5.0	5.100		
Line regulation	$I_{OUT} = 10\text{ mA}$ , $V_{IN} - V_{OUT} = 1.5\text{ V}$ to $13.75\text{ V}$		0.035	0.2		%
	$I_{OUT} = 0\text{ mA}$ , $V_{IN} = 2.9\text{ V}$ to $10\text{ V}$		1	6		mV
	$I_{OUT} = 0\text{ mA}$ , $V_{IN} = 3.2\text{ V}$ to $10\text{ V}$		1	6		
	$I_{OUT} = 0\text{ mA}$ , $V_{IN} = 3.9\text{ V}$ to $10\text{ V}$		1	6		
	$I_{OUT} = 0\text{ mA}$ , $V_{IN} = 4.75\text{ V}$ to $15\text{ V}$		1	6		
	$I_{OUT} = 0\text{ mA}$ , $V_{IN} = 6.5\text{ V}$ to $15\text{ V}$		1	10		
Load regulation	$I_{OUT} = 10\text{ mA}$ to $800\text{ mA}$ , $V_{IN} - V_{OUT} = 3\text{ V}$		0.2	0.4	%	
	$I_{OUT} = 0$ to $800\text{ mA}$ , $V_{IN} = 2.9\text{ V}$		1	10	mV	
	$I_{OUT} = 0$ to $800\text{ mA}$ , $V_{IN} = 3.2\text{ V}$		1	10		
	$I_{OUT} = 0$ to $800\text{ mA}$ , $V_{IN} = 3.9\text{ V}$		1	10		
	$I_{OUT} = 0$ to $800\text{ mA}$ , $V_{IN} = 4.75\text{ V}$		1	10		
	$I_{OUT} = 0$ to $800\text{ mA}$ , $V_{IN} = 6.5\text{ V}$		1	15		
Dropout voltage, $V_{DO}$ <sup>(2)</sup>	$I_{OUT} = 100\text{ mA}$		1.1	1.2	V	
	$I_{OUT} = 500\text{ mA}$		1.15	1.25		
	$I_{OUT} = 800\text{ mA}$		1.2	1.3		
Current limit	$V_{IN} - V_{OUT} = 5\text{ V}$ , $T_J = 25^\circ\text{C}$ <sup>(3)</sup>	0.8	1.2	1.6	A	
Minimum load current	$V_{IN} = 15\text{ V}$		1.7	5	mA	
Quiescent current	$V_{IN} \leq 15\text{ V}$		5	10	mA	
Thermal regulation	30-ms pulse, $T_A = 25^\circ\text{C}$		0.01	0.1	%/W	
Ripple rejection	$V_{IN} - V_{OUT} = 3\text{ V}$ , $V_{ripple} = 1\text{ V}_{pp}$ , $f = 120\text{ Hz}$	60	75		dB	
ADJ pin current			80	120	$\mu\text{A}$	
Change in ADJ pin current	$V_{IN} - V_{OUT} = 1.4\text{ V}$ to $10\text{ V}$ , $I_{OUT} = 10\text{ mA}$ to $800\text{ mA}$		0.2	5	$\mu\text{A}$	
Temperature stability	$T_J = \text{full range}$		0.5		%	
Long-term stability	1000 hrs, No load, $T_A = 125^\circ\text{C}$		0.3		%	
Output noise voltage (% of $V_{OUT}$ )	$f = 10\text{ Hz}$ to $100\text{ kHz}$		0.003		%	

- (1) All characteristics are measured with a  $10\text{-}\mu\text{F}$  capacitor across the input and a  $10\text{-}\mu\text{F}$  capacitor across the output. Pulse testing techniques are used to maintain the junction temperature as close to the ambient temperature as possible.
- (2) Dropout is defined as the  $V_{IN}$  to  $V_{OUT}$  differential at which  $V_{OUT}$  drops  $100\text{ mV}$  below the value of  $V_{OUT}$ , measured at  $V_{IN} = V_{OUT(nom)} + 1.5\text{ V}$ .
- (3) Current limit test specified under recommended operating conditions

### TLV1117I Electrical Characteristics

$T_J = -40^{\circ}\text{C}$  to  $125^{\circ}\text{C}$ , all typical values are at  $T_J = 25^{\circ}\text{C}$  (unless otherwise noted)

PARAMETER	TEST CONDITIONS <sup>(1)</sup>	MIN	TYP	MAX	UNIT	
Reference voltage, $V_{REF}$	$V_{IN} - V_{OUT} = 2\text{ V}$ , $I_{OUT} = 10\text{ mA}$ , $T_J = 25^{\circ}\text{C}$	1.238	1.25	1.262	V	
	$V_{IN} - V_{OUT} = 1.4\text{ V}$ to $10\text{ V}$ , $I_{OUT} = 10\text{ mA}$ to $800\text{ mA}$	1.200	1.25	1.29		
Output voltage, $V_{OUT}$	$V_{IN} = 3.5\text{ V}$ , $I_{OUT} = 10\text{ mA}$ , $T_J = 25^{\circ}\text{C}$	1.485	1.5	1.515		
	$V_{IN} = 2.9\text{ V}$ to $10\text{ V}$ , $I_{OUT} = 0$ to $800\text{ mA}$	1.44	1.5	1.56		
	$V_{IN} = 3.8\text{ V}$ , $I_{OUT} = 10\text{ mA}$ , $T_J = 25^{\circ}\text{C}$	1.782	1.8	1.818		
	$V_{IN} = 3.2\text{ V}$ to $10\text{ V}$ , $I_{OUT} = 0$ to $800\text{ mA}$	1.728	1.8	1.872		
	$V_{IN} = 4.5\text{ V}$ , $I_{OUT} = 10\text{ mA}$ , $T_J = 25^{\circ}\text{C}$	2.475	2.5	2.525		
	$V_{IN} = 3.9\text{ V}$ to $10\text{ V}$ , $I_{OUT} = 0$ to $800\text{ mA}$	2.4	2.5	2.6		
	$V_{IN} = 5\text{ V}$ , $I_{OUT} = 10\text{ mA}$ , $T_J = 25^{\circ}\text{C}$	3.267	3.3	3.333		
	$V_{IN} = 4.75\text{ V}$ to $10\text{ V}$ , $I_{OUT} = 0$ to $800\text{ mA}$	3.168	3.3	3.432		
	$V_{IN} = 7\text{ V}$ , $I_{OUT} = 10\text{ mA}$ , $T_J = 25^{\circ}\text{C}$	4.95	5.0	5.05		
	$V_{IN} = 6.5\text{ V}$ to $12\text{ V}$ , $I_{OUT} = 0$ to $800\text{ mA}$	4.80	5.0	5.20		
Line regulation	$I_{OUT} = 10\text{ mA}$ , $V_{IN} - V_{OUT} = 1.5\text{ V}$ to $13.75\text{ V}$		0.035	0.3		%
	$I_{OUT} = 0\text{ mA}$ , $V_{IN} = 2.9\text{ V}$ to $10\text{ V}$		1	10		mV
	$I_{OUT} = 0\text{ mA}$ , $V_{IN} = 3.2\text{ V}$ to $10\text{ V}$		1	10		
	$I_{OUT} = 0\text{ mA}$ , $V_{IN} = 3.9\text{ V}$ to $10\text{ V}$		1	10		
	$I_{OUT} = 0\text{ mA}$ , $V_{IN} = 4.75\text{ V}$ to $15\text{ V}$		1	10		
	$I_{OUT} = 0\text{ mA}$ , $V_{IN} = 6.5\text{ V}$ to $15\text{ V}$		1	15		
Load regulation	$I_{OUT} = 10\text{ mA}$ to $800\text{ mA}$ , $V_{IN} - V_{OUT} = 3\text{ V}$		0.2	0.5	%	
	$I_{OUT} = 0$ to $800\text{ mA}$ , $V_{IN} = 2.9\text{ V}$		1	15	mV	
	$I_{OUT} = 0$ to $800\text{ mA}$ , $V_{IN} = 3.2\text{ V}$		1	15		
	$I_{OUT} = 0$ to $800\text{ mA}$ , $V_{IN} = 3.9\text{ V}$		1	15		
	$I_{OUT} = 0$ to $800\text{ mA}$ , $V_{IN} = 4.75\text{ V}$		1	15		
	$I_{OUT} = 0$ to $800\text{ mA}$ , $V_{IN} = 6.5\text{ V}$		1	20		
Dropout voltage, $V_{DO}$ <sup>(2)</sup>	$I_{OUT} = 100\text{ mA}$		1.1	1.3	V	
	$I_{OUT} = 500\text{ mA}$		1.15	1.35		
	$I_{OUT} = 800\text{ mA}$		1.2	1.4		
Current limit	$V_{IN} - V_{OUT} = 5\text{ V}$ , $T_J = 25^{\circ}\text{C}$ <sup>(3)</sup>	0.8	1.2	1.6	A	
Minimum load current	$V_{IN} = 15\text{ V}$		1.7	5	mA	
Quiescent current	$V_{IN} \leq 15\text{ V}$		5	15	mA	
Thermal regulation	30-ms pulse, $T_A = 25^{\circ}\text{C}$		0.01	0.1	%/W	
Ripple rejection	$V_{IN} - V_{OUT} = 3\text{ V}$ , $V_{ripple} = 1\text{ V}_{pp}$ , $f = 120\text{ Hz}$	60	75		dB	
ADJ pin current			80	120	$\mu\text{A}$	
Change in ADJ pin current	$V_{IN} - V_{OUT} = 1.4\text{ V}$ to $10\text{ V}$ , $I_{OUT} = 10\text{ mA}$ to $800\text{ mA}$		0.2	10	$\mu\text{A}$	
Temperature stability	$T_J = \text{full range}$		0.5		%	
Long-term stability	1000 hrs, No load, $T_A = 125^{\circ}\text{C}$		0.3		%	
Output noise voltage (% of $V_{OUT}$ )	$f = 10\text{ Hz}$ to $100\text{ kHz}$		0.003		%	

- (1) All characteristics are measured with a 10- $\mu\text{F}$  capacitor across the input and a 10- $\mu\text{F}$  capacitor across the output. Pulse testing techniques are used to maintain the junction temperature as close to the ambient temperature as possible.
- (2) Dropout is defined as the  $V_{IN}$  to  $V_{OUT}$  differential at which  $V_{OUT}$  drops 100 mV below the value of  $V_{OUT}$ , measured at  $V_{IN} = V_{OUT(nom)} + 1.5\text{ V}$ .
- (3) Current limit test specified under recommended operating conditions

TYPICAL CHARACTERISTICS

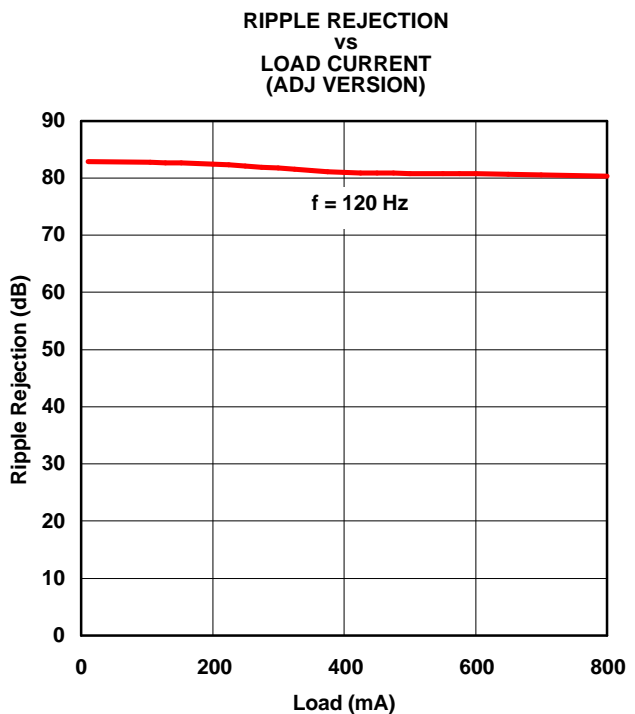
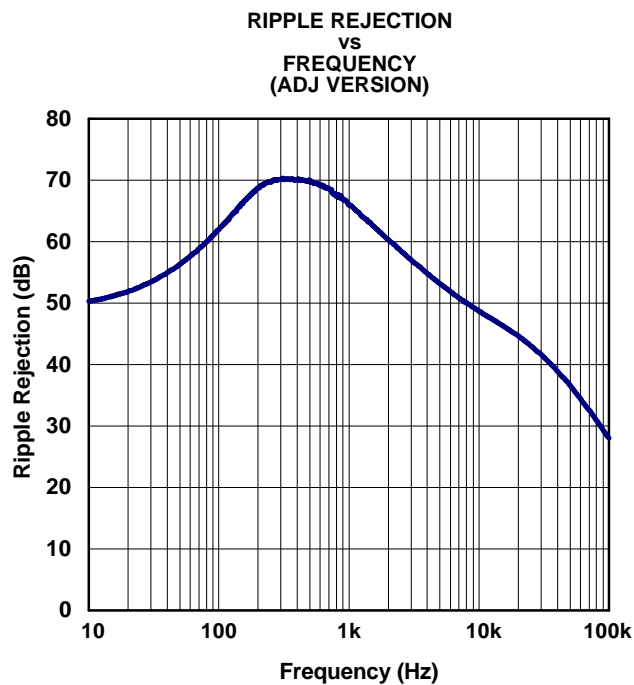
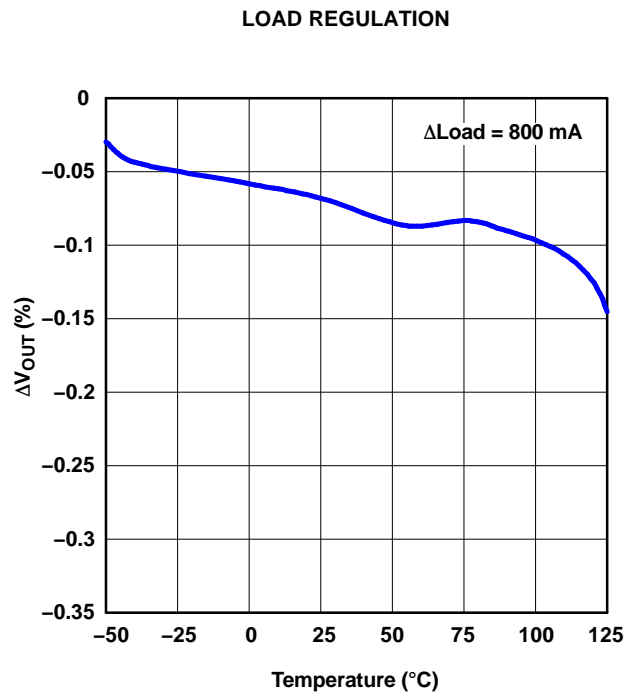
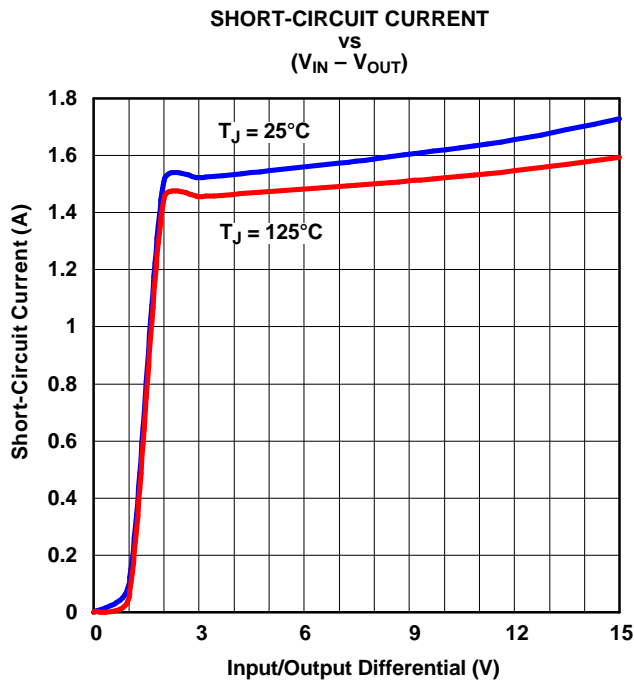

**TYPICAL CHARACTERISTICS (continued)**

**TEMPERATURE STABILITY**

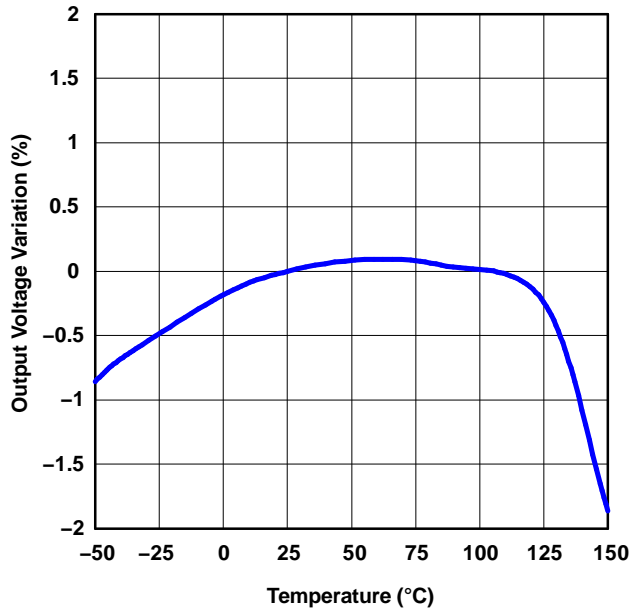

**ADJ PIN CURRENT  
VS  
TEMPERATURE**

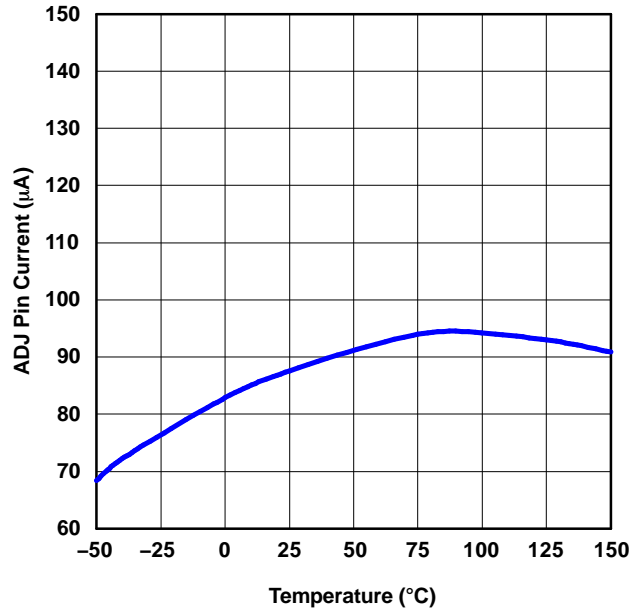

**TLV1117-33 LOAD TRANSIENT RESPONSE**

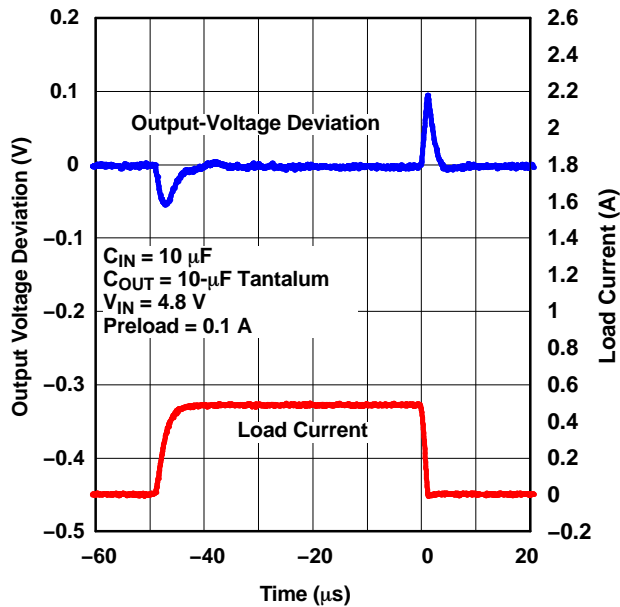

**TLV1117-33 LINE TRANSIENT RESPONSE**

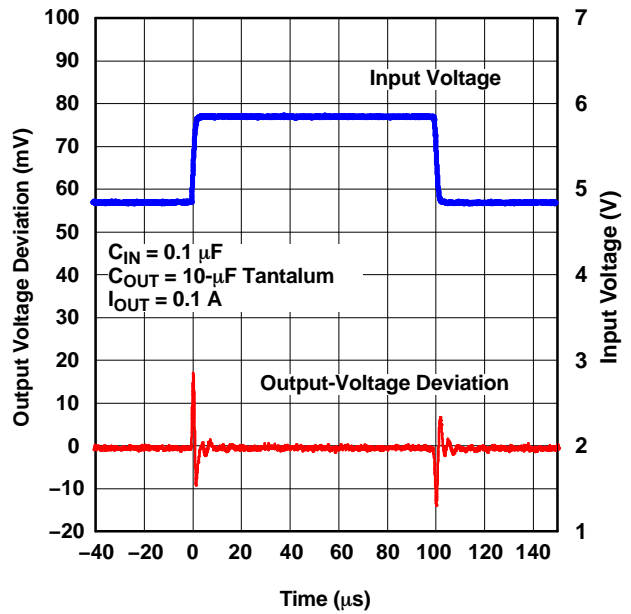

TYPICAL CHARACTERISTICS (continued)

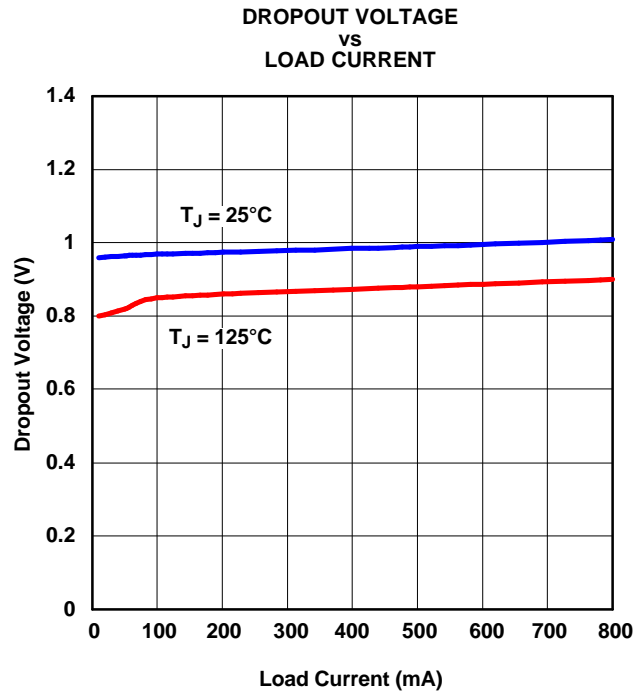

**APPLICATION INFORMATION**

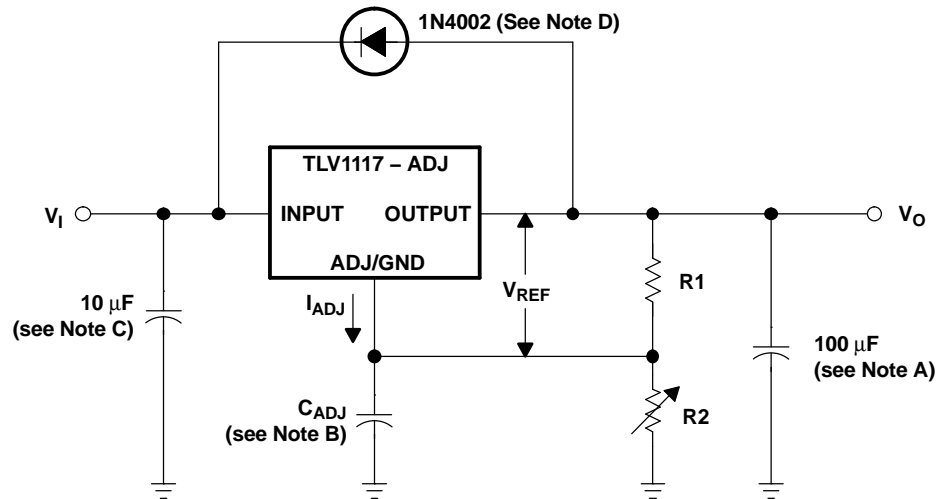

$V_{OUT}$  is calculated as:

$$V_{OUT} = V_{REF} \left( 1 + \frac{R2}{R1} \right) + (I_{ADJ} \times R2)$$

Because  $I_{ADJ}$  typically is 55  $\mu$ A, it is negligible in most applications.

- A. Output capacitor selection is critical for regulator stability. Larger  $C_{OUT}$  values benefit the regulator by improving transient response and loop stability.
- B.  $C_{ADJ}$  can be used to improve ripple rejection. If  $C_{ADJ}$  is used, a  $C_{OUT}$  that is larger in value than  $C_{ADJ}$  must be used.
- C.  $C_{IN}$  is recommended if TLV1117 is not located near the power-supply filter.
- D. An external diode is recommended to protect the regulator if the input instantaneously is shorted to GND.
- E. This device is designed to be stable with tantalum and aluminum electrolytic output capacitors having an ESR between 0.2  $\Omega$  and 10  $\Omega$ .

**Figure 1. Basic Adjustable Regulator**

**PACKAGING INFORMATION**

Orderable Device	Status <sup>(1)</sup>	Package Type	Package Drawing	Pins	Package Qty	Eco Plan <sup>(2)</sup>	Lead/Ball Finish	MSL Peak Temp <sup>(3)</sup>
TLV1117-15CDCY	ACTIVE	SOT-223	DCY	4	80	TBD	CU SNPB	Level-2-235C-1 YEAR
TLV1117-15CDCYRG3	ACTIVE	SOT-223	DCY	4	80	Green (RoHS & no Sb/Br)	CU SN	Level-2-260C-1YEAR
TLV1117-15CDCYR	ACTIVE	SOT-223	DCY	4	2500	TBD	CU SNPB	Level-2-235C-1 YEAR
TLV1117-15CDCYRG3	ACTIVE	SOT-223	DCY	4	2500	Green (RoHS & no Sb/Br)	CU SN	Level-2-260C-1YEAR
TLV1117-15CDRJ	ACTIVE	SON	DRJ	8	1000	Green (RoHS & no Sb/Br)	CU NIPDAU	Level-2-260C-1YEAR
TLV1117-15CDRJRG4	ACTIVE	SON	DRJ	8	1000	Green (RoHS & no Sb/Br)	CU NIPDAU	Level-2-260C-1YEAR
TLV1117-15CKCS	PREVIEW	TO-220	KCS	3	50	TBD	Call TI	Call TI
TLV1117-15CKVURG3	ACTIVE	PFM	KVU	3	2500	Green (RoHS & no Sb/Br)	CU SN	Level-3-260C-168 HR
TLV1117-15IDCY	ACTIVE	SOT-223	DCY	4	80	TBD	CU SNPB	Level-2-235C-1 YEAR
TLV1117-15IDCYG3	ACTIVE	SOT-223	DCY	4	80	Green (RoHS & no Sb/Br)	CU SN	Level-2-260C-1YEAR
TLV1117-15IDCYR	ACTIVE	SOT-223	DCY	4	2500	TBD	CU SNPB	Level-2-235C-1 YEAR
TLV1117-15IDCYRG3	ACTIVE	SOT-223	DCY	4	2500	Green (RoHS & no Sb/Br)	CU SN	Level-2-260C-1YEAR
TLV1117-15IDRJ	ACTIVE	SON	DRJ	8	1000	Green (RoHS & no Sb/Br)	CU NIPDAU	Level-2-260C-1YEAR
TLV1117-15IDRJRG4	ACTIVE	SON	DRJ	8	1000	Green (RoHS & no Sb/Br)	CU NIPDAU	Level-2-260C-1YEAR
TLV1117-15IKCS	PREVIEW	TO-220	KCS	3	50	TBD	Call TI	Call TI
TLV1117-15IKVURG3	ACTIVE	PFM	KVU	3	2500	Green (RoHS & no Sb/Br)	CU SN	Level-3-260C-168 HR
TLV1117-18CDCY	ACTIVE	SOT-223	DCY	4	80	TBD	CU SNPB	Level-2-235C-1 YEAR
TLV1117-18CDCYRG3	ACTIVE	SOT-223	DCY	4	80	Green (RoHS & no Sb/Br)	CU SN	Level-2-260C-1YEAR
TLV1117-18CDCYR	ACTIVE	SOT-223	DCY	4	2500	TBD	CU SNPB	Level-2-235C-1 YEAR
TLV1117-18CDCYRG3	ACTIVE	SOT-223	DCY	4	2500	Green (RoHS & no Sb/Br)	CU SN	Level-2-260C-1YEAR
TLV1117-18CDRJ	ACTIVE	SON	DRJ	8	1000	Green (RoHS & no Sb/Br)	CU NIPDAU	Level-2-260C-1YEAR
TLV1117-18CDRJRG4	ACTIVE	SON	DRJ	8	1000	Green (RoHS & no Sb/Br)	CU NIPDAU	Level-2-260C-1YEAR
TLV1117-18CKCS	PREVIEW	TO-220	KCS	3	50	TBD	Call TI	Call TI
TLV1117-18CKVURG3	ACTIVE	PFM	KVU	3	2500	Green (RoHS & no Sb/Br)	CU SN	Level-3-260C-168 HR
TLV1117-18IDCY	ACTIVE	SOT-223	DCY	4	80	TBD	CU SNPB	Level-2-235C-1 YEAR
TLV1117-18IDCYG3	ACTIVE	SOT-223	DCY	4	80	Green (RoHS & no Sb/Br)	CU SN	Level-2-260C-1YEAR
TLV1117-18IDCYR	ACTIVE	SOT-223	DCY	4	2500	TBD	CU SNPB	Level-2-235C-1 YEAR
TLV1117-18IDCYRG3	ACTIVE	SOT-223	DCY	4	2500	Green (RoHS & no Sb/Br)	CU SN	Level-2-260C-1YEAR
TLV1117-18IDRJ	ACTIVE	SON	DRJ	8	1000	Green (RoHS & no Sb/Br)	CU NIPDAU	Level-2-260C-1YEAR

Orderable Device	Status <sup>(1)</sup>	Package Type	Package Drawing	Pins	Package Qty	Eco Plan <sup>(2)</sup>	Lead/Ball Finish	MSL Peak Temp <sup>(3)</sup>
TLV1117-18IDRJRG4	ACTIVE	SON	DRJ	8	1000	Green (RoHS & no Sb/Br)	CU NIPDAU	Level-2-260C-1YEAR
TLV1117-18IKCS	PREVIEW	TO-220	KCS	3	50	TBD	Call TI	Call TI
TLV1117-18IKVURG3	ACTIVE	PFM	KVU	3	2500	Green (RoHS & no Sb/Br)	CU SN	Level-3-260C-168 HR
TLV1117-25CDCY	ACTIVE	SOT-223	DCY	4	80	TBD	CU SNPB	Level-2-235C-1 YEAR
TLV1117-25CDCYG3	ACTIVE	SOT-223	DCY	4	80	Green (RoHS & no Sb/Br)	CU SN	Level-2-260C-1YEAR
TLV1117-25CDCYR	ACTIVE	SOT-223	DCY	4	2500	TBD	CU SNPB	Level-2-235C-1 YEAR
TLV1117-25CDCYRG3	ACTIVE	SOT-223	DCY	4	2500	Green (RoHS & no Sb/Br)	CU SN	Level-2-260C-1YEAR
TLV1117-25CDRJR	ACTIVE	SON	DRJ	8	1000	Green (RoHS & no Sb/Br)	CU NIPDAU	Level-2-260C-1YEAR
TLV1117-25CDRJRG4	ACTIVE	SON	DRJ	8	1000	Green (RoHS & no Sb/Br)	CU NIPDAU	Level-2-260C-1YEAR
TLV1117-25CKCS	PREVIEW	TO-220	KCS	3	50	TBD	Call TI	Call TI
TLV1117-25CKTPR	PREVIEW	PFM	KTP	2	3000	TBD	Call TI	Call TI
TLV1117-25CKVURG3	ACTIVE	PFM	KVU	3	2500	Green (RoHS & no Sb/Br)	CU SN	Level-3-260C-168 HR
TLV1117-25IDCY	ACTIVE	SOT-223	DCY	4	80	TBD	CU SNPB	Level-2-235C-1 YEAR
TLV1117-25IDCYG3	ACTIVE	SOT-223	DCY	4	80	Green (RoHS & no Sb/Br)	CU SN	Level-2-260C-1YEAR
TLV1117-25IDCYR	ACTIVE	SOT-223	DCY	4	2500	TBD	CU SNPB	Level-2-235C-1 YEAR
TLV1117-25IDCYRG3	ACTIVE	SOT-223	DCY	4	2500	Green (RoHS & no Sb/Br)	CU SN	Level-2-260C-1YEAR
TLV1117-25IDRJR	ACTIVE	SON	DRJ	8	1000	Green (RoHS & no Sb/Br)	CU NIPDAU	Level-2-260C-1YEAR
TLV1117-25IDRJRG4	ACTIVE	SON	DRJ	8	1000	Green (RoHS & no Sb/Br)	CU NIPDAU	Level-2-260C-1YEAR
TLV1117-25IKCS	PREVIEW	TO-220	KCS	3	50	TBD	Call TI	Call TI
TLV1117-25IKVURG3	ACTIVE	PFM	KVU	3	2500	Green (RoHS & no Sb/Br)	CU SN	Level-3-260C-168 HR
TLV1117-33CDCY	ACTIVE	SOT-223	DCY	4	80	TBD	CU SNPB	Level-2-235C-1 YEAR
TLV1117-33CDCYG3	ACTIVE	SOT-223	DCY	4	80	Green (RoHS & no Sb/Br)	CU SN	Level-2-260C-1YEAR
TLV1117-33CDCYR	ACTIVE	SOT-223	DCY	4	2500	TBD	CU SNPB	Level-2-235C-1 YEAR
TLV1117-33CDCYRG3	ACTIVE	SOT-223	DCY	4	2500	Green (RoHS & no Sb/Br)	CU SN	Level-2-260C-1YEAR
TLV1117-33CDRJR	ACTIVE	SON	DRJ	8	1000	Green (RoHS & no Sb/Br)	CU NIPDAU	Level-2-260C-1YEAR
TLV1117-33CDRJRG4	ACTIVE	SON	DRJ	8	1000	Green (RoHS & no Sb/Br)	CU NIPDAU	Level-2-260C-1YEAR
TLV1117-33CKCS	PREVIEW	TO-220	KCS	3	50	TBD	Call TI	Call TI
TLV1117-33CKTTR	PREVIEW	DDPAK/ TO-263	KTT	3	1000	TBD	Call TI	Call TI
TLV1117-33CKVURG3	ACTIVE	PFM	KVU	3	2500	Green (RoHS & no Sb/Br)	CU SN	Level-3-260C-168 HR
TLV1117-33IDCY	ACTIVE	SOT-223	DCY	4	80	TBD	CU SNPB	Level-2-235C-1 YEAR
TLV1117-33IDCYG3	ACTIVE	SOT-223	DCY	4	80	Green (RoHS & no Sb/Br)	CU SN	Level-2-260C-1YEAR

Orderable Device	Status <sup>(1)</sup>	Package Type	Package Drawing	Pins	Package Qty	Eco Plan <sup>(2)</sup>	Lead/Ball Finish	MSL Peak Temp <sup>(3)</sup>
						no Sb/Br)		
TLV1117-33IDCYR	ACTIVE	SOT-223	DCY	4	2500	TBD	CU SNPB	Level-2-235C-1 YEAR
TLV1117-33IDCYRG3	ACTIVE	SOT-223	DCY	4	2500	Green (RoHS & no Sb/Br)	CU SN	Level-2-260C-1YEAR
TLV1117-33IDRJR	ACTIVE	SON	DRJ	8	1000	Green (RoHS & no Sb/Br)	CU NIPDAU	Level-2-260C-1YEAR
TLV1117-33IDRJRG4	ACTIVE	SON	DRJ	8	1000	Green (RoHS & no Sb/Br)	CU NIPDAU	Level-2-260C-1YEAR
TLV1117-33IKCS	PREVIEW	TO-220	KCS	3	50	TBD	Call TI	Call TI
TLV1117-33IKVURG3	ACTIVE	PFM	KVU	3	2500	Green (RoHS & no Sb/Br)	CU SN	Level-3-260C-168 HR
TLV1117-50CDCY	ACTIVE	SOT-223	DCY	4	80	TBD	CU SNPB	Level-2-235C-1 YEAR
TLV1117-50CDCYG3	ACTIVE	SOT-223	DCY	4	80	Green (RoHS & no Sb/Br)	CU SN	Level-2-260C-1YEAR
TLV1117-50CDCYR	ACTIVE	SOT-223	DCY	4	2500	TBD	CU SNPB	Level-2-235C-1 YEAR
TLV1117-50CDCYRG3	ACTIVE	SOT-223	DCY	4	2500	Green (RoHS & no Sb/Br)	CU SN	Level-2-260C-1YEAR
TLV1117-50CDRJR	ACTIVE	SON	DRJ	8	1000	Green (RoHS & no Sb/Br)	CU NIPDAU	Level-2-260C-1YEAR
TLV1117-50CDRJRG4	ACTIVE	SON	DRJ	8	1000	Green (RoHS & no Sb/Br)	CU NIPDAU	Level-2-260C-1YEAR
TLV1117-50CKCS	PREVIEW	TO-220	KCS	3	50	TBD	Call TI	Call TI
TLV1117-50CKTTR	PREVIEW	DDPAK/ TO-263	KTT	3		TBD	Call TI	Call TI
TLV1117-50CKVURG3	ACTIVE	PFM	KVU	3	2500	Green (RoHS & no Sb/Br)	CU SN	Level-3-260C-168 HR
TLV1117-50IDCY	ACTIVE	SOT-223	DCY	4	80	TBD	CU SNPB	Level-2-235C-1 YEAR
TLV1117-50IDCYG3	ACTIVE	SOT-223	DCY	4	80	Green (RoHS & no Sb/Br)	CU SN	Level-2-260C-1YEAR
TLV1117-50IDCYR	ACTIVE	SOT-223	DCY	4	2500	TBD	CU SNPB	Level-2-235C-1 YEAR
TLV1117-50IDCYRG3	ACTIVE	SOT-223	DCY	4	2500	Green (RoHS & no Sb/Br)	CU SN	Level-2-260C-1YEAR
TLV1117-50IDRJR	ACTIVE	SON	DRJ	8	1000	Green (RoHS & no Sb/Br)	CU NIPDAU	Level-2-260C-1YEAR
TLV1117-50IDRJRG4	ACTIVE	SON	DRJ	8	1000	Green (RoHS & no Sb/Br)	CU NIPDAU	Level-2-260C-1YEAR
TLV1117-50IKVURG3	ACTIVE	PFM	KVU	3	2500	Green (RoHS & no Sb/Br)	CU SN	Level-3-260C-168 HR
TLV1117CDCY	ACTIVE	SOT-223	DCY	4	80	TBD	CU SNPB	Level-2-235C-1 YEAR
TLV1117CDCYG3	ACTIVE	SOT-223	DCY	4	80	Green (RoHS & no Sb/Br)	CU SN	Level-2-260C-1YEAR
TLV1117CDCYR	ACTIVE	SOT-223	DCY	4	2500	TBD	CU SNPB	Level-2-235C-1 YEAR
TLV1117CDRJR	ACTIVE	SON	DRJ	8	1000	Green (RoHS & no Sb/Br)	CU NIPDAU	Level-2-260C-1YEAR
TLV1117CDRJRG4	ACTIVE	SON	DRJ	8	1000	Green (RoHS & no Sb/Br)	CU NIPDAU	Level-2-260C-1YEAR
TLV1117CKCS	ACTIVE	TO-220	KCS	3	50	TBD	CU SN	N / A for Pkg Type
TLV1117CKCSE3	ACTIVE	TO-220	KCS	3	50	Pb-Free (RoHS)	CU SN	N / A for Pkg Type

Orderable Device	Status <sup>(1)</sup>	Package Type	Package Drawing	Pins	Package Qty	Eco Plan <sup>(2)</sup>	Lead/Ball Finish	MSL Peak Temp <sup>(3)</sup>
TLV1117CKTER	NRND	PFM	KTE	3	2000	TBD	CU SNPB	Level-1-220C-UNLIM
TLV1117CKTPR	NRND	PFM	KTP	2	3000	TBD	CU SNPB	Level-1-220C-UNLIM
TLV1117CKTPRG3	NRND	PFM	KTP	2	3000	Green (RoHS & no Sb/Br)	CU SN	Level-1-260C-UNLIM
TLV1117CKTTR	ACTIVE	DDPAK/TO-263	KTT	3	1000	Green (RoHS & no Sb/Br)	CU SN	Level-3-245C-168 HR
TLV1117CKVURG3	ACTIVE	PFM	KVU	3	2500	Green (RoHS & no Sb/Br)	CU SN	Level-3-260C-168 HR
TLV1117IDCY	ACTIVE	SOT-223	DCY	4	80	TBD	CU SNPB	Level-2-235C-1 YEAR
TLV1117IDCYG3	ACTIVE	SOT-223	DCY	4	80	Green (RoHS & no Sb/Br)	CU SN	Level-2-260C-1YEAR
TLV1117IDCYR	ACTIVE	SOT-223	DCY	4	2500	TBD	CU SNPB	Level-2-235C-1 YEAR
TLV1117IDRJR	ACTIVE	SON	DRJ	8	1000	Green (RoHS & no Sb/Br)	CU NIPDAU	Level-2-260C-1YEAR
TLV1117IDRJRG4	ACTIVE	SON	DRJ	8	1000	Green (RoHS & no Sb/Br)	CU NIPDAU	Level-2-260C-1YEAR
TLV1117IKCS	ACTIVE	TO-220	KCS	3	50	TBD	CU SN	N / A for Pkg Type
TLV1117IKCSE3	ACTIVE	TO-220	KCS	3	50	Pb-Free (RoHS)	CU SN	N / A for Pkg Type
TLV1117IKTER	NRND	PFM	KTE	3	2000	TBD	CU SNPB	Level-1-220C-UNLIM
TLV1117IKTPR	NRND	PFM	KTP	2	3000	TBD	CU SNPB	Level-1-220C-UNLIM
TLV1117IKTPRG3	NRND	PFM	KTP	2	3000	Green (RoHS & no Sb/Br)	CU SN	Level-1-260C-UNLIM
TLV1117IKTTR	ACTIVE	DDPAK/TO-263	KTT	3	1000	Green (RoHS & no Sb/Br)	CU SN	Level-3-245C-168 HR
TLV1117IKVURG3	ACTIVE	PFM	KVU	3	2500	Green (RoHS & no Sb/Br)	CU SN	Level-3-260C-168 HR

<sup>(1)</sup> The marketing status values are defined as follows:

**ACTIVE:** Product device recommended for new designs.

**LIFEBUY:** TI has announced that the device will be discontinued, and a lifetime-buy period is in effect.

**NRND:** Not recommended for new designs. Device is in production to support existing customers, but TI does not recommend using this part in a new design.

**PREVIEW:** Device has been announced but is not in production. Samples may or may not be available.

**OBSELETE:** TI has discontinued the production of the device.

<sup>(2)</sup> Eco Plan - The planned eco-friendly classification: Pb-Free (RoHS), Pb-Free (RoHS Exempt), or Green (RoHS & no Sb/Br) - please check <http://www.ti.com/productcontent> for the latest availability information and additional product content details.

**TBD:** The Pb-Free/Green conversion plan has not been defined.

**Pb-Free (RoHS):** TI's terms "Lead-Free" or "Pb-Free" mean semiconductor products that are compatible with the current RoHS requirements for all 6 substances, including the requirement that lead not exceed 0.1% by weight in homogeneous materials. Where designed to be soldered at high temperatures, TI Pb-Free products are suitable for use in specified lead-free processes.

**Pb-Free (RoHS Exempt):** This component has a RoHS exemption for either 1) lead-based flip-chip solder bumps used between the die and package, or 2) lead-based die adhesive used between the die and leadframe. The component is otherwise considered Pb-Free (RoHS compatible) as defined above.

**Green (RoHS & no Sb/Br):** TI defines "Green" to mean Pb-Free (RoHS compatible), and free of Bromine (Br) and Antimony (Sb) based flame retardants (Br or Sb do not exceed 0.1% by weight in homogeneous material)

<sup>(3)</sup> MSL, Peak Temp. -- The Moisture Sensitivity Level rating according to the JEDEC industry standard classifications, and peak solder temperature.

**Important Information and Disclaimer:** The information provided on this page represents TI's knowledge and belief as of the date that it is provided. TI bases its knowledge and belief on information provided by third parties, and makes no representation or warranty as to the accuracy of such information. Efforts are underway to better integrate information from third parties. TI has taken and continues to take

reasonable steps to provide representative and accurate information but may not have conducted destructive testing or chemical analysis on incoming materials and chemicals. TI and TI suppliers consider certain information to be proprietary, and thus CAS numbers and other limited information may not be available for release.

In no event shall TI's liability arising out of such information exceed the total purchase price of the TI part(s) at issue in this document sold by TI to Customer on an annual basis.

DCY (R-PDSO-G4)

PLASTIC SMALL-OUTLINE

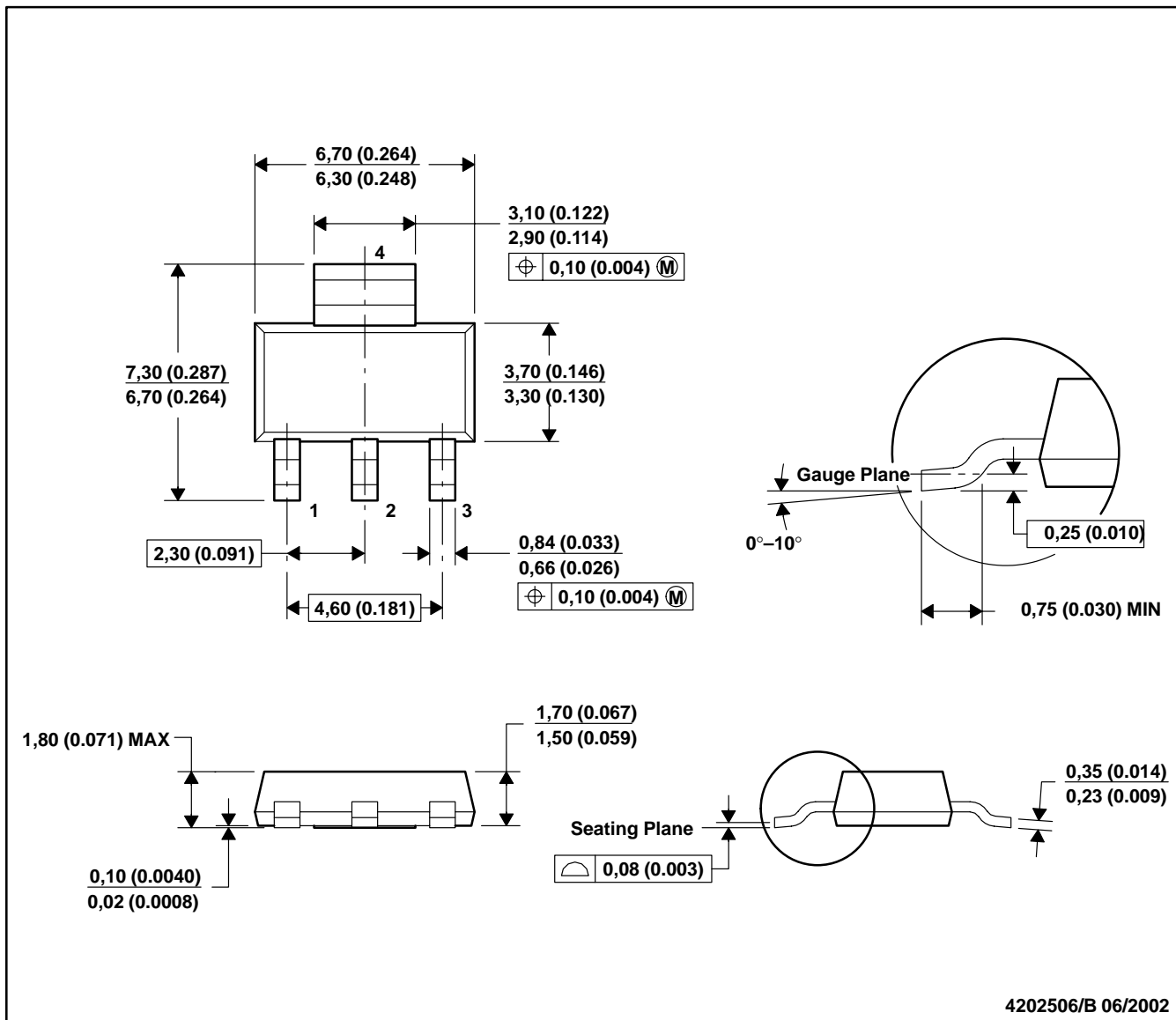

- NOTES: A. All linear dimensions are in millimeters (inches).  
 B. This drawing is subject to change without notice.  
 C. Body dimensions do not include mold flash or protrusion.  
 D. Falls within JEDEC TO-261 Variation AA.

DRJ (S-PDSO-N8)

PLASTIC SMALL OUTLINE

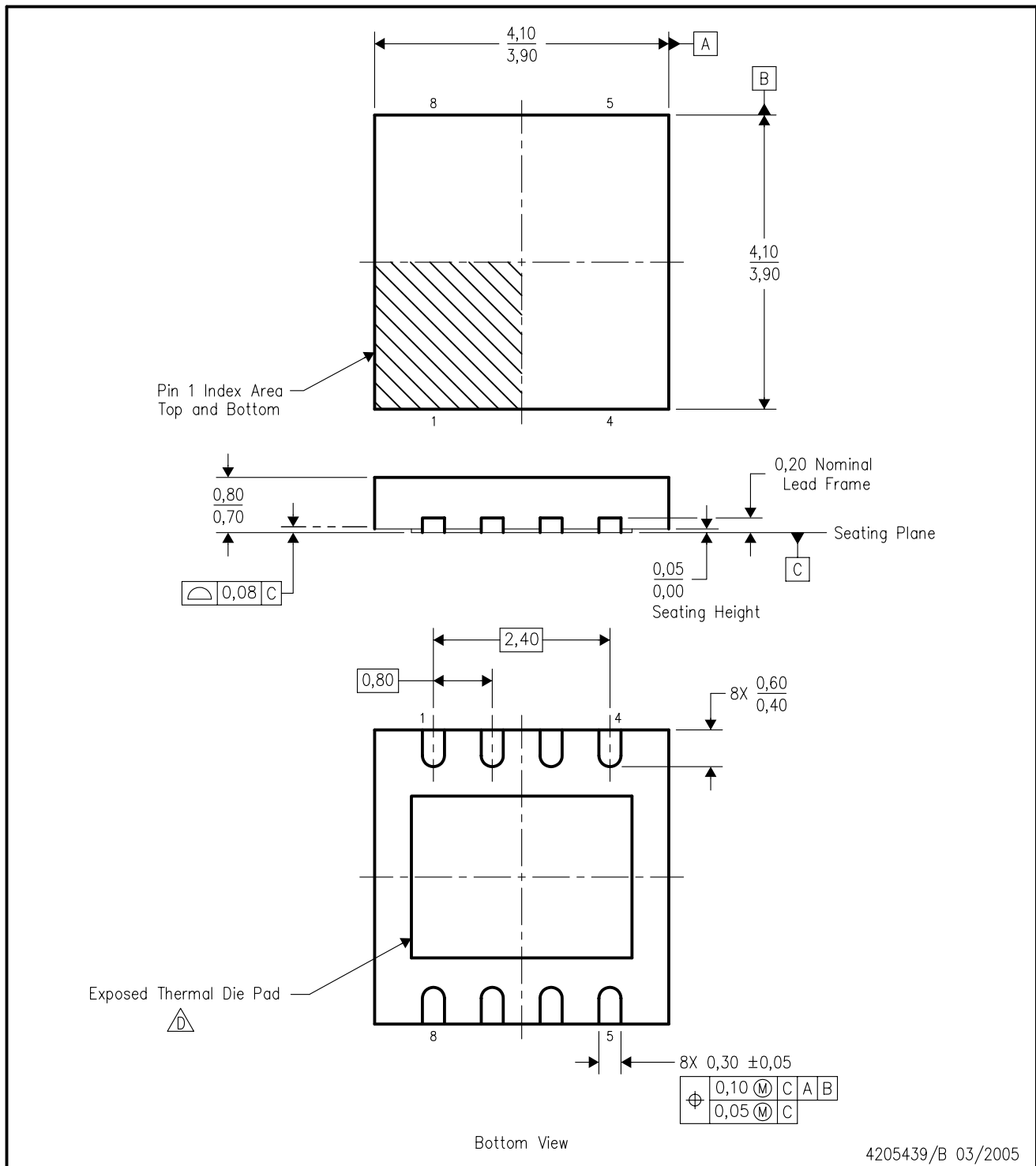

4205439/B 03/2005

- NOTES:
- A. All linear dimensions are in millimeters. Dimensioning and tolerancing per ASME Y14.5M-1994.
  - B. This drawing is subject to change without notice.
  - C. SON (Small Outline No-Lead) package configuration.
  -  The package thermal pad must be soldered to the board for thermal and mechanical performance. See the Product Data Sheet for details regarding the exposed thermal pad dimensions.
  - E. Package complies to JEDEC MO-229 variation WGGB.

KTE (R-PSFM-G3)

PowerFLEX™ PLASTIC FLANGE-MOUNT

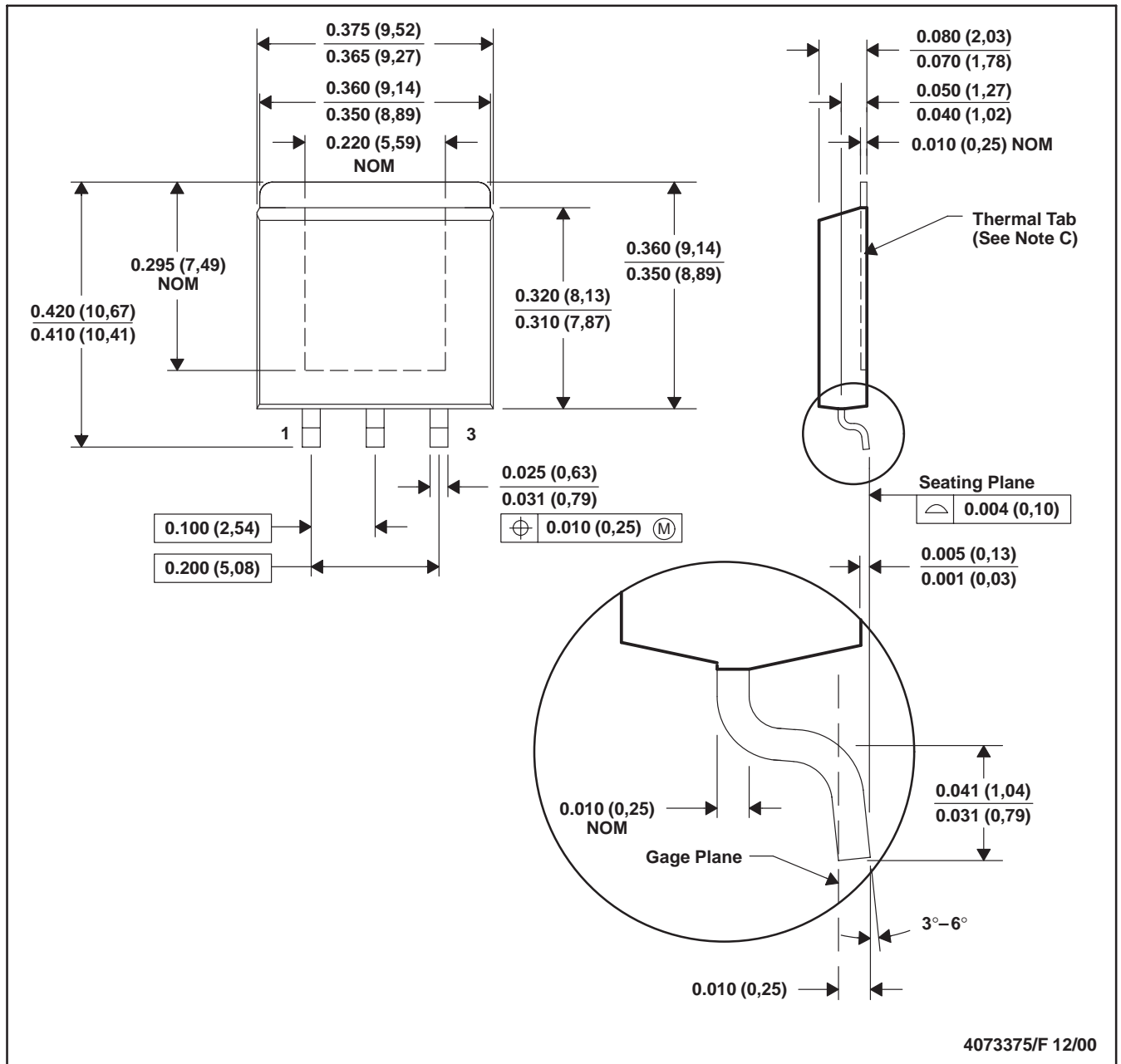

- NOTES: A. All linear dimensions are in inches (millimeters).  
 B. This drawing is subject to change without notice.  
 C. The center lead is in electrical contact with the thermal tab.  
 D. Dimensions do not include mold protrusions, not to exceed 0.006 (0,15).  
 E. Falls within JEDEC MO-169

PowerFLEX is a trademark of Texas Instruments.



KTP (R-PSFM-G2)

PowerFLEX™ PLASTIC FLANGE-MOUNT PACKAGE

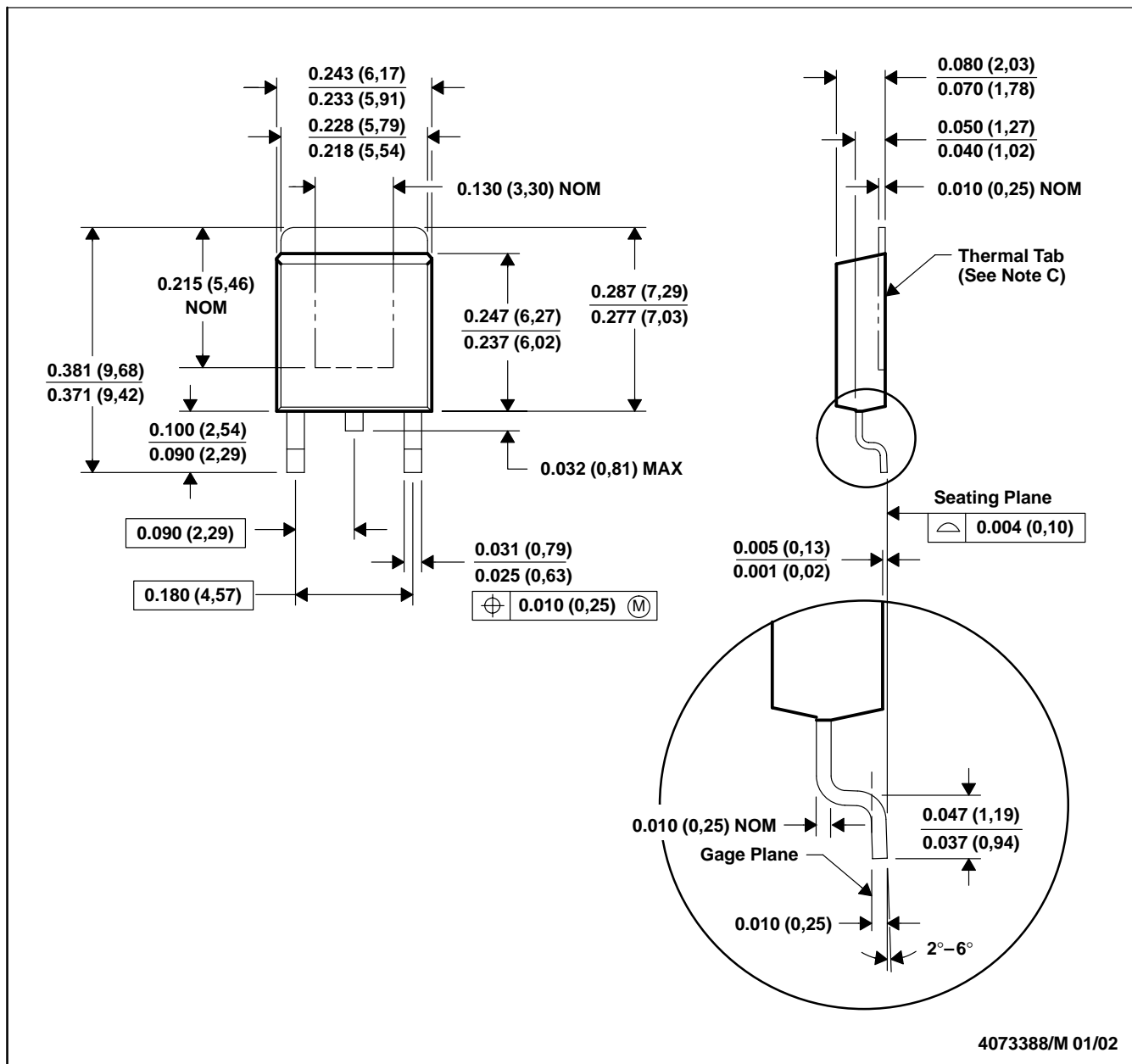

- NOTES: A. All linear dimensions are in inches (millimeters).  
 B. This drawing is subject to change without notice.  
 C. The center lead is in electrical contact with the thermal tab.  
 D. Dimensions do not include mold protrusions, not to exceed 0.006 (0,15).  
 E. Falls within JEDEC TO-252 variation AC.

PowerFLEX is a trademark of Texas Instruments.



KTT (R-PSFM-G3)

PLASTIC FLANGE-MOUNT PACKAGE

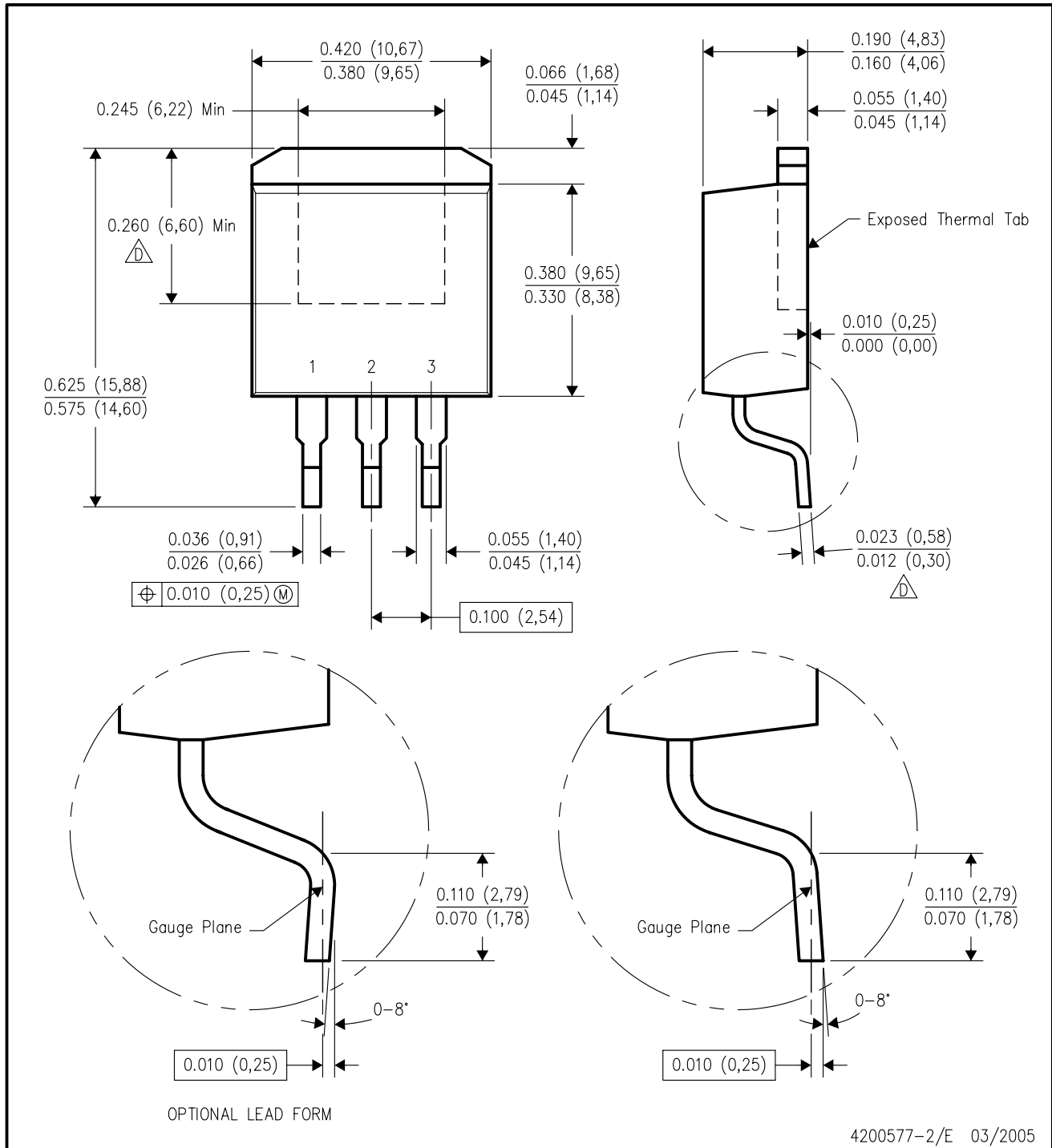

- NOTES:
- A. All linear dimensions are in inches (millimeters).
  - B. This drawing is subject to change without notice.
  - C. Body dimensions do not include mold flash or protrusion. Mold flash or protrusion not to exceed 0.005 (0,13) per side.
- △ Falls within JEDEC TO-263 variation AA, except minimum lead thickness and minimum exposed pad length.

KCS (R-PSFM-T3)

PLASTIC FLANGE-MOUNT PACKAGE

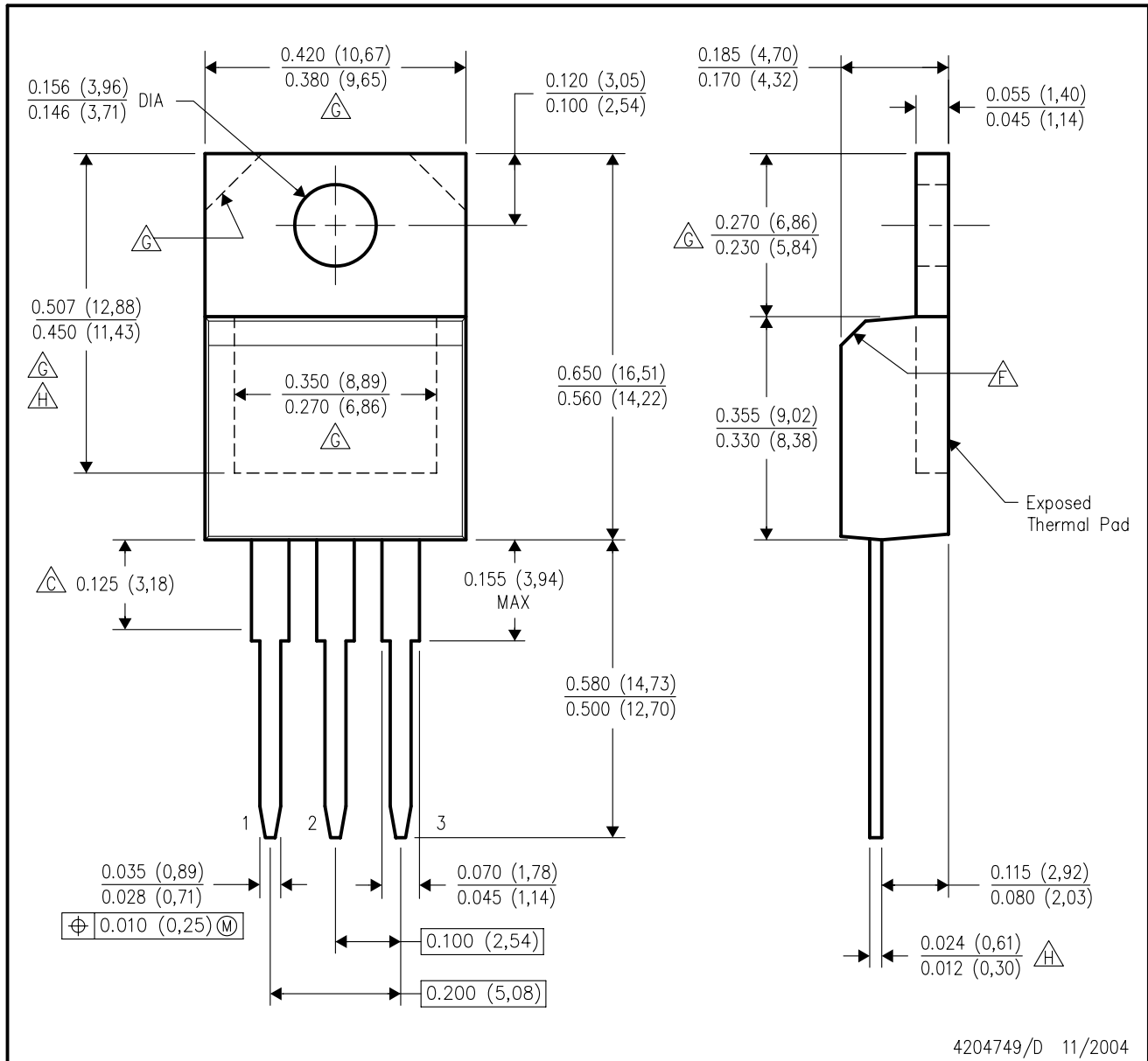

- NOTES:
- A. All linear dimensions are in inches (millimeters).
  - B. This drawing is subject to change without notice.
  - C. Lead dimensions are not controlled within this area.
  - D. All lead dimensions apply before solder dip.
  - E. The center lead is in electrical contact with the mounting tab.
  - F. The chamfer is optional.
  - G. Thermal pad contour optional within these dimensions.
  - H. Falls within JEDEC TO-220 variation AB, except minimum lead thickness and minimum exposed pad length.

KVU (R-PSFM-G3)

PLASTIC FLANGE-MOUNT PACKAGE

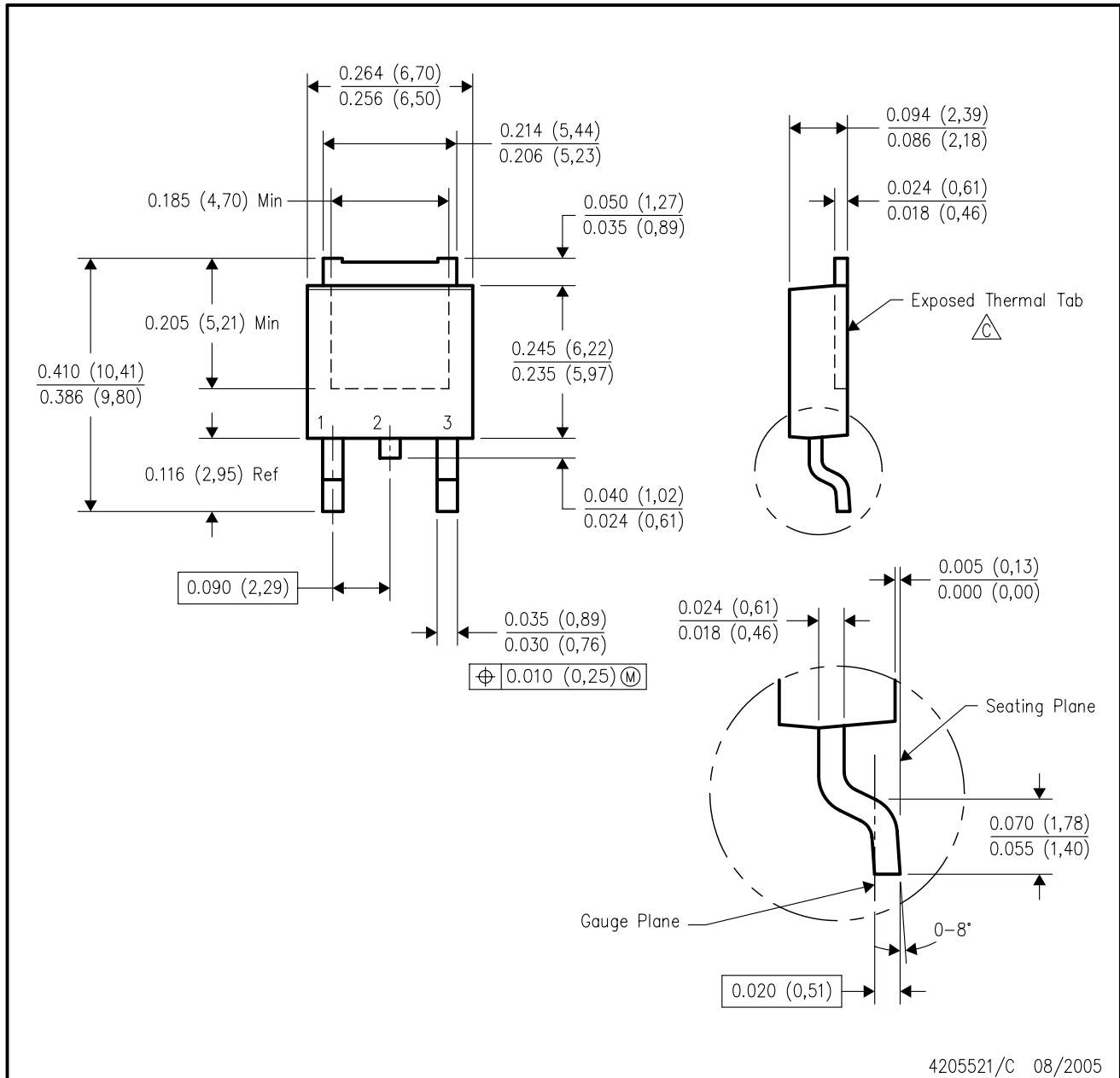

- NOTES:
- A. All linear dimensions are in inches (millimeters).
  - B. This drawing is subject to change without notice.
  - $\triangle C$  The center lead is in electrical contact with the exposed thermal tab.
  - D. Body Dimensions do not include mold flash or protrusions. Mold flash and protrusion shall not exceed 0.006 (0,15) per side.
  - E. Falls within JEDEC TO-252 variation AA.

## IMPORTANT NOTICE

Texas Instruments Incorporated and its subsidiaries (TI) reserve the right to make corrections, modifications, enhancements, improvements, and other changes to its products and services at any time and to discontinue any product or service without notice. Customers should obtain the latest relevant information before placing orders and should verify that such information is current and complete. All products are sold subject to TI's terms and conditions of sale supplied at the time of order acknowledgment.

TI warrants performance of its hardware products to the specifications applicable at the time of sale in accordance with TI's standard warranty. Testing and other quality control techniques are used to the extent TI deems necessary to support this warranty. Except where mandated by government requirements, testing of all parameters of each product is not necessarily performed.

TI assumes no liability for applications assistance or customer product design. Customers are responsible for their products and applications using TI components. To minimize the risks associated with customer products and applications, customers should provide adequate design and operating safeguards.

TI does not warrant or represent that any license, either express or implied, is granted under any TI patent right, copyright, mask work right, or other TI intellectual property right relating to any combination, machine, or process in which TI products or services are used. Information published by TI regarding third-party products or services does not constitute a license from TI to use such products or services or a warranty or endorsement thereof. Use of such information may require a license from a third party under the patents or other intellectual property of the third party, or a license from TI under the patents or other intellectual property of TI.

Reproduction of information in TI data books or data sheets is permissible only if reproduction is without alteration and is accompanied by all associated warranties, conditions, limitations, and notices. Reproduction of this information with alteration is an unfair and deceptive business practice. TI is not responsible or liable for such altered documentation.

Resale of TI products or services with statements different from or beyond the parameters stated by TI for that product or service voids all express and any implied warranties for the associated TI product or service and is an unfair and deceptive business practice. TI is not responsible or liable for any such statements.

Following are URLs where you can obtain information on other Texas Instruments products and application solutions:

<b>Products</b>		<b>Applications</b>	
Amplifiers	<a href="http://amplifier.ti.com">amplifier.ti.com</a>	Audio	<a href="http://www.ti.com/audio">www.ti.com/audio</a>
Data Converters	<a href="http://dataconverter.ti.com">dataconverter.ti.com</a>	Automotive	<a href="http://www.ti.com/automotive">www.ti.com/automotive</a>
DSP	<a href="http://dsp.ti.com">dsp.ti.com</a>	Broadband	<a href="http://www.ti.com/broadband">www.ti.com/broadband</a>
Interface	<a href="http://interface.ti.com">interface.ti.com</a>	Digital Control	<a href="http://www.ti.com/digitalcontrol">www.ti.com/digitalcontrol</a>
Logic	<a href="http://logic.ti.com">logic.ti.com</a>	Military	<a href="http://www.ti.com/military">www.ti.com/military</a>
Power Mgmt	<a href="http://power.ti.com">power.ti.com</a>	Optical Networking	<a href="http://www.ti.com/opticalnetwork">www.ti.com/opticalnetwork</a>
Microcontrollers	<a href="http://microcontroller.ti.com">microcontroller.ti.com</a>	Security	<a href="http://www.ti.com/security">www.ti.com/security</a>
Low Power Wireless	<a href="http://www.ti.com/lpw">www.ti.com/lpw</a>	Telephony	<a href="http://www.ti.com/telephony">www.ti.com/telephony</a>
		Video & Imaging	<a href="http://www.ti.com/video">www.ti.com/video</a>
		Wireless	<a href="http://www.ti.com/wireless">www.ti.com/wireless</a>

Mailing Address: Texas Instruments  
Post Office Box 655303 Dallas, Texas 75265

Copyright © 2006, Texas Instruments Incorporated