

SN64BCT757 OCTAL BUFFER/DRIVER WITH OPEN-COLLECTOR OUTPUTS

SCBS479 – MARCH 1993 – REVISED MAY 1994

- BiCMOS Design Significantly Reduces I_{CCZ}
- ESD Protection Exceeds 2000 V Per MIL-STD-883C, Method 3015; Exceeds 200 V Using Machine Model ($C = 200$ pF, $R = 0$)
- High-Impedance State During Power Up and Power Down
- Open-Collector Outputs Drive Bus Lines or Buffer-Memory Address Registers
- Package Options Include Plastic Small-Outline (DW) Packages and Standard Plastic and Ceramic 300-mil DIPs (N)

DW OR N PACKAGE
(TOP VIEW)

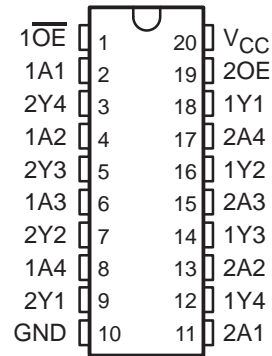

description

This octal buffer and line driver is designed specifically to improve both the performance and density of 3-state memory address drivers, clock drivers, and bus-oriented receivers and transmitters. The device provides complementary output-enable (OE and \overline{OE}) inputs and noninverting outputs.

The SN64BCT757 is characterized for operation from -40°C to 85°C and 0°C to 70°C .

FUNCTION TABLES

INPUTS		OUTPUT
$\overline{1OE}$	1A	1Y
H	X	H
L	L	L
L	H	H

INPUTS		OUTPUT
2OE	2A	2Y
L	X	H
H	L	L
H	H	H

SN64BCT757

OCTAL BUFFER/DRIVER

WITH OPEN-COLLECTOR OUTPUTS

SCBS479 – MARCH 1993 – REVISED MAY 1994

logic symbol†

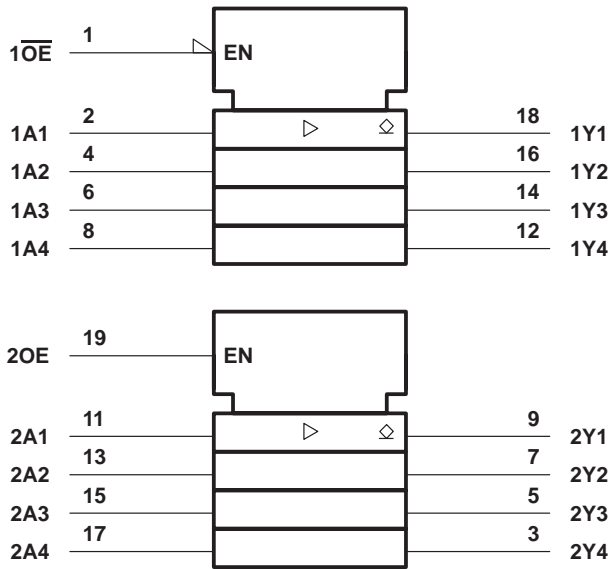

† This symbol is in accordance with ANSI/IEEE Std 91-1984 and IEC Publication 617-12.

logic diagram (positive logic)

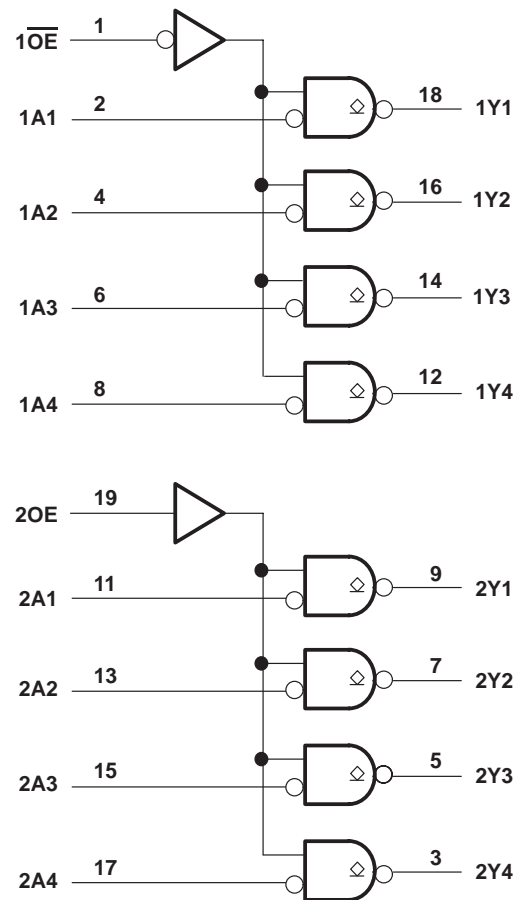

absolute maximum ratings over operating free-air temperature range (unless otherwise noted)‡

Supply voltage range, V_{CC}	-0.5 V to 7 V
Input voltage range, V_I (see Note 1)	-0.5 V to 7 V
Voltage range applied to any output in the disabled or power-off state, V_O	-0.5 V to 5.5 V
Voltage range applied to any output in the high state, V_O	-0.5 V to V_{CC}
Input clamp current, I_{IK} ($V_I < 0$)	-30 mA
Current into any output in the low state, I_O	128 mA
Operating free-air temperature range	-40°C to 85°C
Storage temperature range	-65°C to 150°C

‡ Stresses beyond those listed under "absolute maximum ratings" may cause permanent damage to the device. These are stress ratings only, and functional operation of the device at these or any other conditions beyond those indicated under "recommended operating conditions" is not implied. Exposure to absolute-maximum-rated conditions for extended periods may affect device reliability.

NOTE 1: The input negative-voltage ratings may be exceeded if the input clamp-current ratings are observed.

recommended operating conditions (see Note 2)

		MIN	NOM	MAX	UNIT
V _{CC}	Supply voltage	4.5	5	5.5	V
V _{IH}	High-level input voltage	2			V
V _{IL}	Low-level input voltage			0.8	V
V _{OH}	High-level output voltage			5.5	V
I _{IK}	Input clamp current			-18	mA
I _{OL}	Low-level output current			64	mA
Δt/ΔV _{CC}	Power-up ramp rate	2			μs/V
T _A	Operating free-air temperature	-40		85	°C

NOTE 2: Unused or floating inputs must be held high or low.

electrical characteristics over recommended operating free-air temperature range (unless otherwise noted)

PARAMETER	TEST CONDITIONS		MIN	TYP†	MAX	UNIT
V _{IK}	V _{CC} = 4.5 V,	I _I = -18 mA			-1.2	V
I _{OH}	V _{CC} = 4.5 V,	V _{OH} = 5.5 V			0.1	mA
V _{OL}	V _{CC} = 4.5 V,	I _{OL} = 64 mA		0.42	0.55	V
I _{OZ}	V _{CC} = 0 to 2.3 V (power up),	V _O = 2.7 V, \overline{OE} = 0.8 V or OE = 2 V			50	μA
I _{OZ}	V _{CC} = 1.8 V to 0 (power down),	V _O = 2.7 V, \overline{OE} = 0.8 V or OE = 2 V			50	μA
I _I	V _{CC} = 5.5 V,	V _I = 7 V			0.1	mA
I _{IH}	V _{CC} = 5.5 V,	V _I = 2.7 V			20	μA
I _{IL}	V _{CC} = 5.5 V,	V _I = 0.5 V			-1	mA
I _{CC}	V _{CC} = 5.5 V,	Outputs open	Outputs high		34	mA
			Outputs low		77	
			OE and \overline{OE} inactive		10	
C _i	V _{CC} = 5 V,	V _I = 2.5 V or 0.5 V		6		pF
C _o	V _{CC} = 5 V,	V _O = 2.5 V or 0.5 V		4		pF

† All typical values are at V_{CC} = 5 V, T_A = 25°C.

switching characteristics over recommended range of supply voltage, C_L = 50 pF (unless otherwise noted) (see Note 3)

PARAMETER	FROM (INPUT)	TO (OUTPUT)	V _{CC} = 5 V, T _A = 25°C			T _A = -40°C to 85°C		T _A = 0°C to 70°C		UNIT
			MIN	TYP	MAX	MIN	MAX	MIN	MAX	
t _{PLH}	A	Y	6.9	8.3	9.6	6.5	11.2	6.6	10.1	ns
t _{PHL}			2.4	4.2	6	1.9	7	2	6.6	
t _{PLH}	2OE	Y	11	14.8	17.9	10.4	21.3	10.8	19.7	ns
t _{PHL}			2.9	4.6	6.2	2.6	7.5	2.6	6.9	
t _{PLH}	$\overline{1OE}$	Y	11.4	13.9	16.1	8.9	19.9	10	18	ns
t _{PHL}			4.4	6.1	7.8	4	9.2	4	8.5	

NOTE 3: Load circuits and voltage waveforms are shown in Section 1.

PACKAGING INFORMATION

Orderable Device	Status ⁽¹⁾	Package Type	Package Drawing	Pins	Package Qty	Eco Plan ⁽²⁾	Lead/Ball Finish	MSL Peak Temp ⁽³⁾
SN64BCT757DW	ACTIVE	SOIC	DW	20	25	Pb-Free (RoHS)	CU NIPDAU	Level-2-250C-1 YEAR/ Level-1-235C-UNLIM
SN64BCT757DWE4	ACTIVE	SOIC	DW	20	25	Pb-Free (RoHS)	CU NIPDAU	Level-2-250C-1 YEAR/ Level-1-235C-UNLIM
SN64BCT757DWR	ACTIVE	SOIC	DW	20	2000	Green (RoHS & no Sb/Br)	CU NIPDAU	Level-1-260C-UNLIM
SN64BCT757DWRE4	ACTIVE	SOIC	DW	20	2000	Green (RoHS & no Sb/Br)	CU NIPDAU	Level-1-260C-UNLIM
SN64BCT757N	ACTIVE	PDIP	N	20	20	Pb-Free (RoHS)	CU NIPDAU	Level-NC-NC-NC
SN64BCT757NE4	ACTIVE	PDIP	N	20	20	Pb-Free (RoHS)	CU NIPDAU	Level-NC-NC-NC

⁽¹⁾ The marketing status values are defined as follows:

ACTIVE: Product device recommended for new designs.

LIFEBUY: TI has announced that the device will be discontinued, and a lifetime-buy period is in effect.

NRND: Not recommended for new designs. Device is in production to support existing customers, but TI does not recommend using this part in a new design.

PREVIEW: Device has been announced but is not in production. Samples may or may not be available.

OBSELETE: TI has discontinued the production of the device.

⁽²⁾ Eco Plan - The planned eco-friendly classification: Pb-Free (RoHS) or Green (RoHS & no Sb/Br) - please check <http://www.ti.com/productcontent> for the latest availability information and additional product content details.

TBD: The Pb-Free/Green conversion plan has not been defined.

Pb-Free (RoHS): TI's terms "Lead-Free" or "Pb-Free" mean semiconductor products that are compatible with the current RoHS requirements for all 6 substances, including the requirement that lead not exceed 0.1% by weight in homogeneous materials. Where designed to be soldered at high temperatures, TI Pb-Free products are suitable for use in specified lead-free processes.

Green (RoHS & no Sb/Br): TI defines "Green" to mean Pb-Free (RoHS compatible), and free of Bromine (Br) and Antimony (Sb) based flame retardants (Br or Sb do not exceed 0.1% by weight in homogeneous material)

⁽³⁾ MSL, Peak Temp. -- The Moisture Sensitivity Level rating according to the JEDEC industry standard classifications, and peak solder temperature.

Important Information and Disclaimer:The information provided on this page represents TI's knowledge and belief as of the date that it is provided. TI bases its knowledge and belief on information provided by third parties, and makes no representation or warranty as to the accuracy of such information. Efforts are underway to better integrate information from third parties. TI has taken and continues to take reasonable steps to provide representative and accurate information but may not have conducted destructive testing or chemical analysis on incoming materials and chemicals. TI and TI suppliers consider certain information to be proprietary, and thus CAS numbers and other limited information may not be available for release.

In no event shall TI's liability arising out of such information exceed the total purchase price of the TI part(s) at issue in this document sold by TI to Customer on an annual basis.

N (R-PDIP-T**)

PLASTIC DUAL-IN-LINE PACKAGE

16 PINS SHOWN

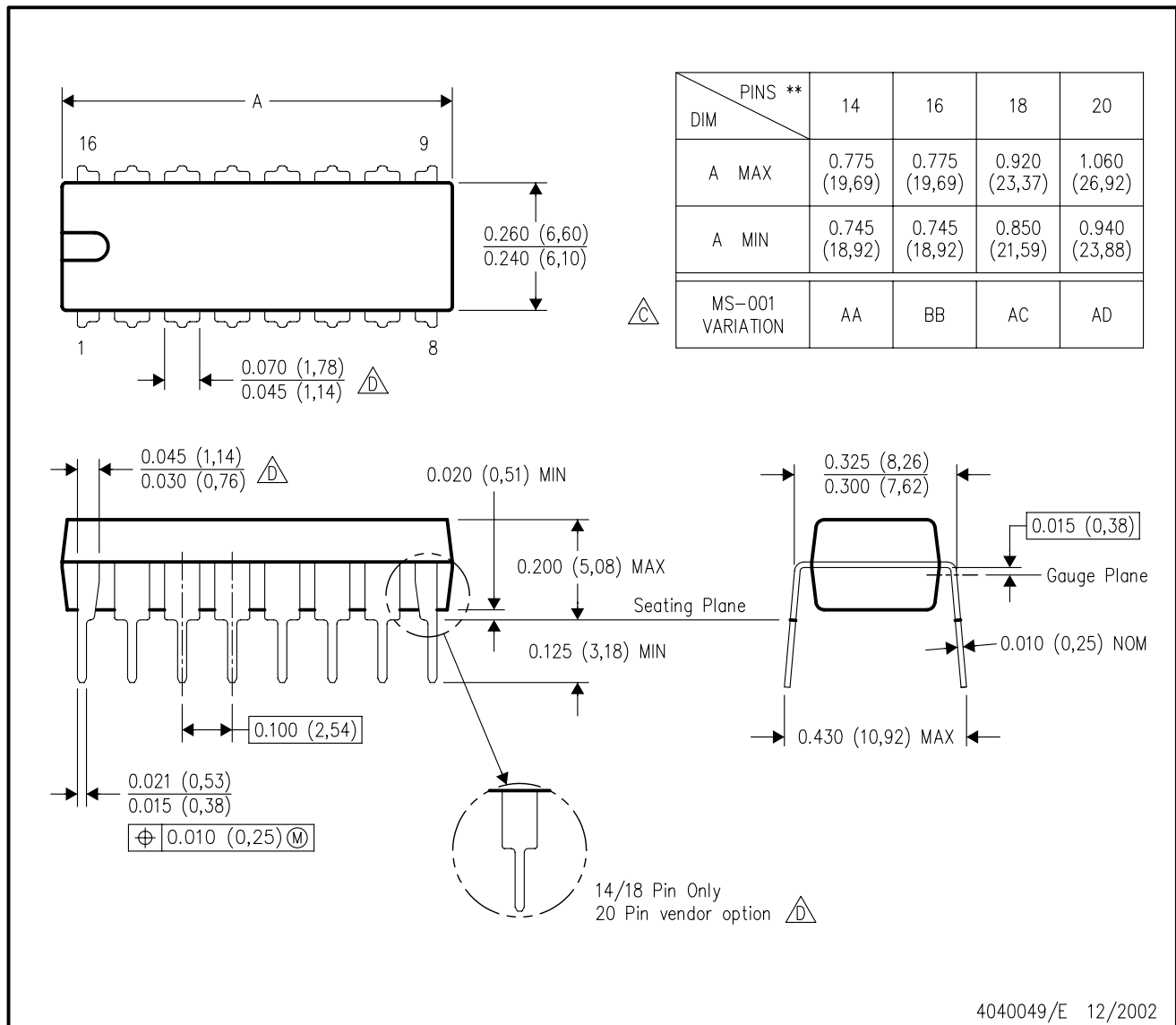

- NOTES:
- A. All linear dimensions are in inches (millimeters).
 - B. This drawing is subject to change without notice.
 - C Falls within JEDEC MS-001, except 18 and 20 pin minimum body length (Dim A).
 - D The 20 pin end lead shoulder width is a vendor option, either half or full width.

4040049/E 12/2002

DW (R-PDSO-G20)

PLASTIC SMALL-OUTLINE PACKAGE

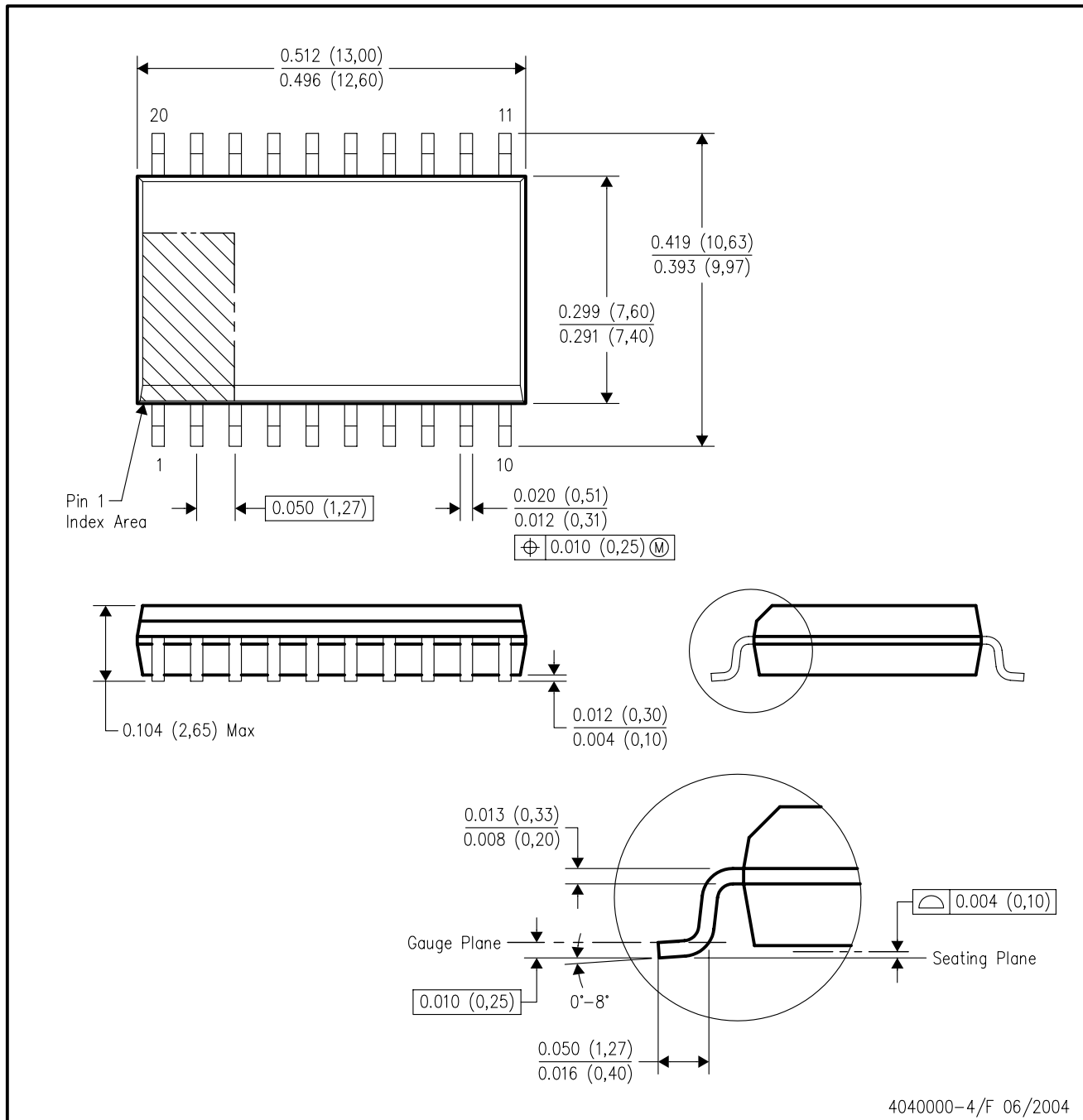

- NOTES:
- A. All linear dimensions are in inches (millimeters).
 - B. This drawing is subject to change without notice.
 - C. Body dimensions do not include mold flash or protrusion not to exceed 0.006 (0,15).
 - D. Falls within JEDEC MS-013 variation AC.

IMPORTANT NOTICE

Texas Instruments Incorporated and its subsidiaries (TI) reserve the right to make corrections, modifications, enhancements, improvements, and other changes to its products and services at any time and to discontinue any product or service without notice. Customers should obtain the latest relevant information before placing orders and should verify that such information is current and complete. All products are sold subject to TI's terms and conditions of sale supplied at the time of order acknowledgment.

TI warrants performance of its hardware products to the specifications applicable at the time of sale in accordance with TI's standard warranty. Testing and other quality control techniques are used to the extent TI deems necessary to support this warranty. Except where mandated by government requirements, testing of all parameters of each product is not necessarily performed.

TI assumes no liability for applications assistance or customer product design. Customers are responsible for their products and applications using TI components. To minimize the risks associated with customer products and applications, customers should provide adequate design and operating safeguards.

TI does not warrant or represent that any license, either express or implied, is granted under any TI patent right, copyright, mask work right, or other TI intellectual property right relating to any combination, machine, or process in which TI products or services are used. Information published by TI regarding third-party products or services does not constitute a license from TI to use such products or services or a warranty or endorsement thereof. Use of such information may require a license from a third party under the patents or other intellectual property of the third party, or a license from TI under the patents or other intellectual property of TI.

Reproduction of information in TI data books or data sheets is permissible only if reproduction is without alteration and is accompanied by all associated warranties, conditions, limitations, and notices. Reproduction of this information with alteration is an unfair and deceptive business practice. TI is not responsible or liable for such altered documentation.

Resale of TI products or services with statements different from or beyond the parameters stated by TI for that product or service voids all express and any implied warranties for the associated TI product or service and is an unfair and deceptive business practice. TI is not responsible or liable for any such statements.

Following are URLs where you can obtain information on other Texas Instruments products and application solutions:

Products		Applications	
Amplifiers	amplifier.ti.com	Audio	www.ti.com/audio
Data Converters	dataconverter.ti.com	Automotive	www.ti.com/automotive
DSP	dsp.ti.com	Broadband	www.ti.com/broadband
Interface	interface.ti.com	Digital Control	www.ti.com/digitalcontrol
Logic	logic.ti.com	Military	www.ti.com/military
Power Mgmt	power.ti.com	Optical Networking	www.ti.com/opticalnetwork
Microcontrollers	microcontroller.ti.com	Security	www.ti.com/security
		Telephony	www.ti.com/telephony
		Video & Imaging	www.ti.com/video
		Wireless	www.ti.com/wireless

Mailing Address: Texas Instruments
Post Office Box 655303 Dallas, Texas 75265