

HIGH-SPEED DIFFERENTIAL LINE RECEIVERS

FEATURES

- Meet or Exceed the Requirements of ANSI TIA/EIA-644 Standard
- Operate With a Single 3.3-V Supply
- Designed for Signaling Rates of up to 100 Mbps (See Table 1)
- Differential Input Thresholds ± 100 mV Max
- Typical Propagation Delay Time of 2.1 ns
- Power Dissipation 60 mW Typical Per Receiver at Maximum Data Rate
- Bus-Terminal ESD Protection Exceeds 8 kV
- Low-Voltage TTL (LVTTTL) Logic Output Levels
- Pin Compatible With AM26LS32, MC3486, and μ A9637
- Open-Circuit Fail-Safe
- Cold Sparring for Space and High Reliability Applications Requiring Redundancy

DESCRIPTION

The SN55LVDS32, SN65LVDS32, SN65LVDS3486, and SN65LVDS9637 are differential line receivers that implement the electrical characteristics of low-voltage differential signaling (LVDS). This signaling technique lowers the output voltage levels of 5-V differential standard levels (such as EIA/TIA-422B) to reduce the power, increase the switching speeds, and allow operation with a 3.3-V supply rail. Any of the four differential receivers provides a valid logical output state with a ± 100 -mV differential input voltage within the input common-mode voltage range. The input common-mode voltage range allows 1 V of ground potential difference between two LVDS nodes.

The intended application of these devices and signaling technique is both point-to-point and multidrop (one driver and multiple receivers) data transmission over controlled impedance media of approximately 100 Ω . The transmission media may be printed-circuit board traces, backplanes, or cables. The ultimate rate and distance of data transfer depends on the attenuation characteristics of the media and the noise coupling to the environment.

SN55LVDS32 . . . J OR W
SN65LVDS32 . . . D OR PW
(Marked as LVDS32 or 65LVDS32)

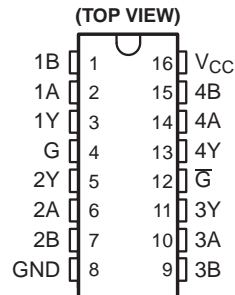

SN55LVDS32FK
(TOP VIEW)

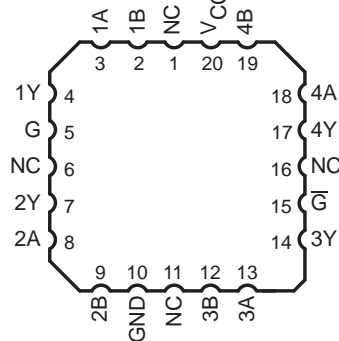

SN65LVDS3486D (Marked as LVDS3486)
(TOP VIEW)

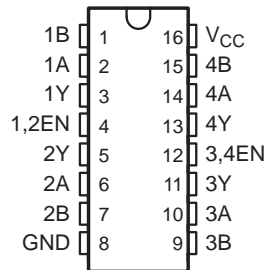

SN65LVDS9637D (Marked as DK637 or LVDS37)
SN65LVDS9637DGN (Marked as L37)
SN65LVDS9637DGK (Marked as AXF)
(TOP VIEW)

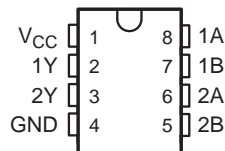

Please be aware that an important notice concerning availability, standard warranty, and use in critical applications of Texas Instruments semiconductor products and disclaimers thereto appears at the end of this data sheet.

PowerPAD is a trademark of Texas Instruments.



These devices have limited built-in ESD protection. The leads should be shorted together or the device placed in conductive foam during storage or handling to prevent electrostatic damage to the MOS gates.

DESCRIPTION (CONTINUED)

The SN65LVDS32, SN65LVDS3486, and SN65LVDS9637 are characterized for operation from -40°C to 85°C . The SN55LVDS32 is characterized for operation from -55°C to 125°C .

Table 1. Maximum Recommended Operating Speeds

Part Number	All Rx Active
SN65LVDS32	100 Mbps
SN65LVDS3486	100 Mbps
SN65LVDS9637	150 Mbps

AVAILABLE OPTIONS

T _A	PACKAGE ⁽¹⁾					
	SMALL OUTLINE		MSOP	CHIP CARRIER (FK)	CERAMIC DIP (J)	FLAT PACK (W)
	(D)	(PW)				
-40°C to 85°C	SN65LVDS32D	SN65LVDS32PW	—	—	—	—
	SN65LVDS3486D	—	—	—	—	—
	SN65LVDS9637D	—	SN65LVDS9637DGN	—	—	—
	—	—	SN65LVDS9637DGK	—	—	—
-55°C to 125°C	—	—	—	SNJ55LVDS32FK	SNJ55LVDS32J	SNJ55LVDS32W SN55LVDS32W

(1) For the most current package and ordering information, see the Package Option Addendum at the end of this document, or see the TI website at www.ti.com.

'LVDS32 logic diagram (positive logic)

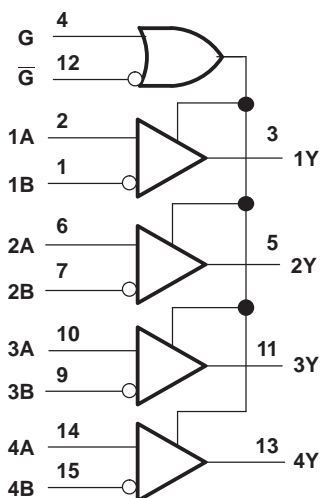

SN65LVDS3486D logic diagram (positive logic)

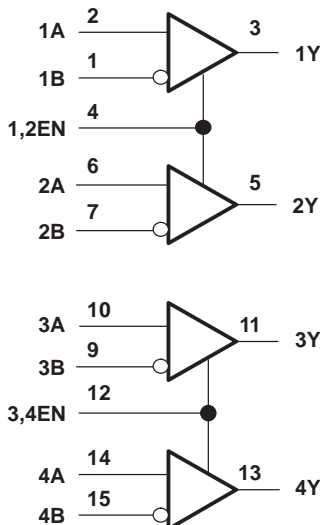

SN65LVDS9637D logic diagram (positive logic)

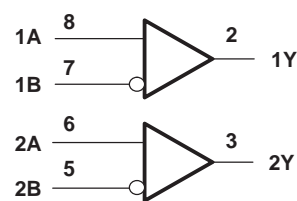

FUNCTION TABLES

SN55LVDS32, SN65LVDS32 ⁽¹⁾				SN65LVDS3486 ⁽¹⁾		
DIFFERENTIAL INPUT A, B	ENABLES		OUTPUT Y	DIFFERENTIAL INPUT A, B	ENABLE EN	OUTPUT Y
	G	\bar{G}				
$V_{ID} \geq 100$ mV	H X	X L	H H	$V_{ID} \geq 100$ mV	H	H
-100 mV < V_{ID} < 100 mV	H X	X L	? ?	-100 mV < V_{ID} < 100 mV	H	?
$V_{ID} \leq -100$ mV	H X	X L	L L	$V_{ID} \leq -100$ mV	H	L
X	L	H	Z	X	L	Z
Open	H X	X L	H H	Open	H	H

(1) H = high level, L = low level, X = irrelevant, Z = high impedance (off), ? = indeterminate

logic symbols†

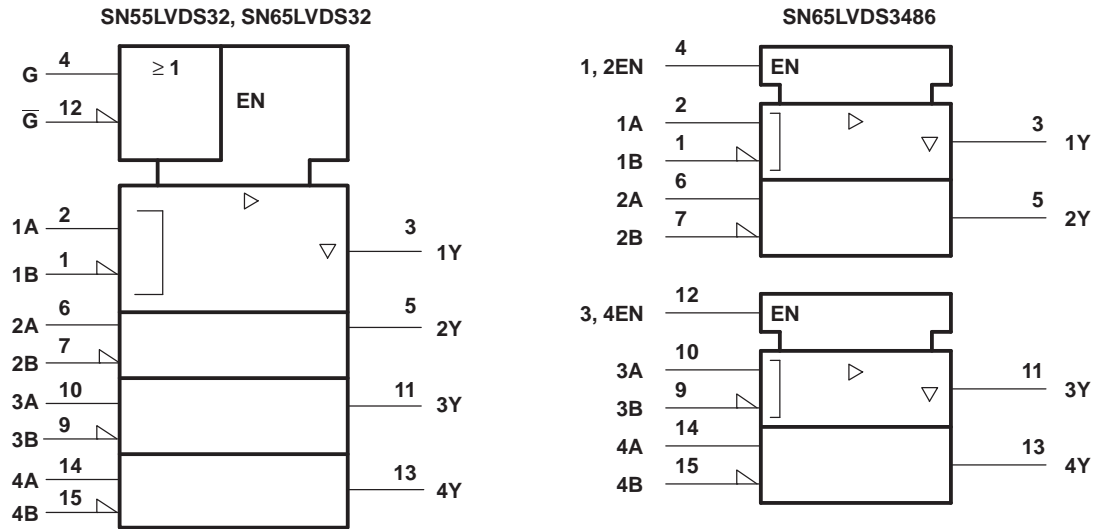

† This symbol is in accordance with ANSI/IEEE Std 91-1984 and IEC Publication 617-12.

Function Table
SN65LVDS9637

DIFFERENTIAL INPUT A, B	OUTPUT Y
$V_{ID} \geq 100$ mV	H
-100 mV < V_{ID} < 100 mV	?
$V_{ID} \leq -100$ mV	L
Open	H

H = high level, L = low level, ? = indeterminate

logic symbol†

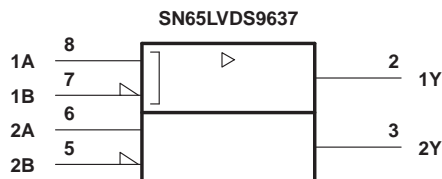

† This symbol is in accordance with ANSI/IEEE Std 91-1984 and IEC Publication 617-12.

EQUIVALENT INPUT AND OUTPUT SCHEMATIC DIAGRAMS

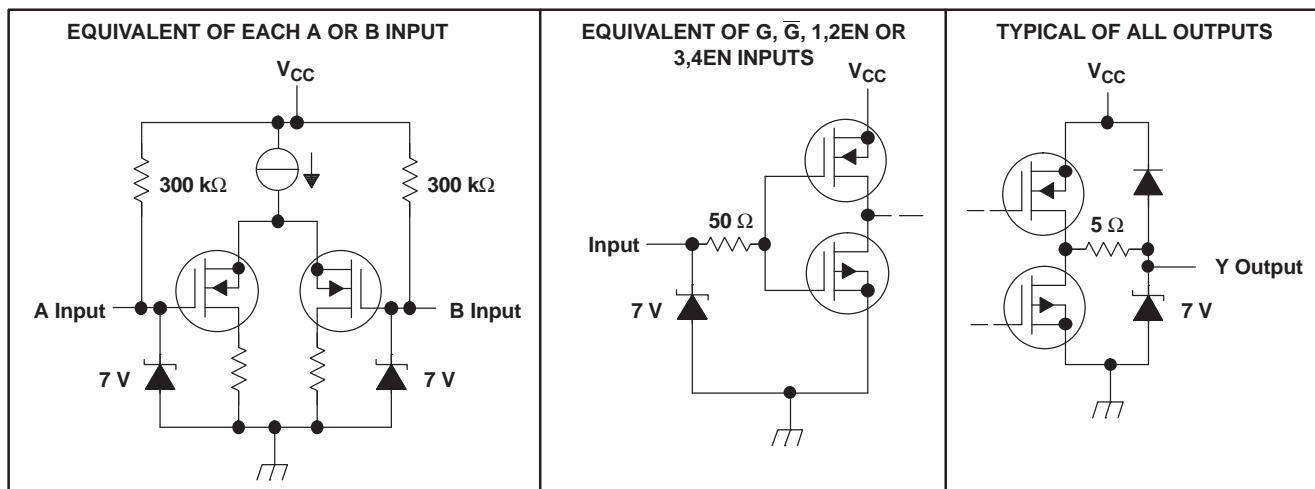

ABSOLUTE MAXIMUM RATINGS

over operating free-air temperature range (unless otherwise noted)⁽¹⁾

		UNIT
V_{CC}	Supply voltage range ⁽²⁾	–0.5 V to 4 V
V_I	Input voltage range	–0.5 V to $V_{CC} + 0.5$ V
	Enables and output A or B	–0.5 V to 4 V
Continuous total power dissipation		See Dissipation Rating Table
Lead temperature 1,6 mm (1/16 inch) from case for 10 seconds		260°C
T_{stg}	Storage temperature range	–65°C to 150°C

- (1) Stresses beyond those listed under *absolute maximum ratings* may cause permanent damage to the device. These are stress ratings only, and functional operation of the device at these or any other conditions beyond those indicated under *recommended operating conditions* is not implied. Exposure to absolute-maximum-rated conditions for extended periods may affect device reliability.
- (2) All voltages, except differential I/O bus voltages, are with respect to the network ground terminal.

DISSIPATION RATING TABLE

PACKAGE	$T_A \leq 25^\circ\text{C}$ POWER RATING	DERATING FACTOR ⁽¹⁾ ABOVE $T_A = 25^\circ\text{C}$	$T_A = 70^\circ\text{C}$ POWER RATING	$T_A = 85^\circ\text{C}$ POWER RATING	$T_A = 125^\circ\text{C}$ POWER RATING
D (8)	725 mW	5.8 mW/°C	464 mW	377 mW	—
D (16)	950 mW	7.6 mW/°C	608 mW	494 mW	—
DGK	425 mW	3.4 mW/°C	272 mW	221 mW	—
DGN ⁽²⁾	2.14 W	17.1 mW/°C	1.37 W	1.11 W	—
FK	1375 mW	11.0 mW/°C	880 mW	715 mW	275 mW
J	1375 mW	11.0 mW/°C	880 mW	715 mW	275 mW
PW (16)	774 mW	6.2 mW/°C	496 mW	402 mW	—
W	1000 mW	8.0 mW/°C	640 mW	520 mW	200 mW

(1) This is the inverse of the junction-to-ambient thermal resistance when board mounted and with no air flow.

(2) The PowerPAD™ must be soldered to a thermal land on the printed-circuit board. See the application note *PowerPAD Thermally Enhanced Package (SLMA002)*

RECOMMENDED OPERATING CONDITIONS

		MIN	NOM	MAX	UNIT
V_{CC}	Supply voltage	3	3.3	3.6	V
V_{IH}	High-level input voltage	G, \bar{G} , 1,2EN, or 3,4EN		2	V
V_{IL}	Low-level input voltage	G, \bar{G} , 1,2EN, or 3,4EN		0.8	V
$ V_{ID} $	Magnitude of differential input voltage	0.1		0.6	V
V_{IC}	Common-mode input voltage (see Figure 1)	$\frac{ V_{ID} }{2}$		$2.4 - \frac{ V_{ID} }{2}$	V
				$V_{CC} - 0.8$	
T_A	Operating free-air temperature	SN65 prefix		-40	°C
		SN55 prefix		-55	

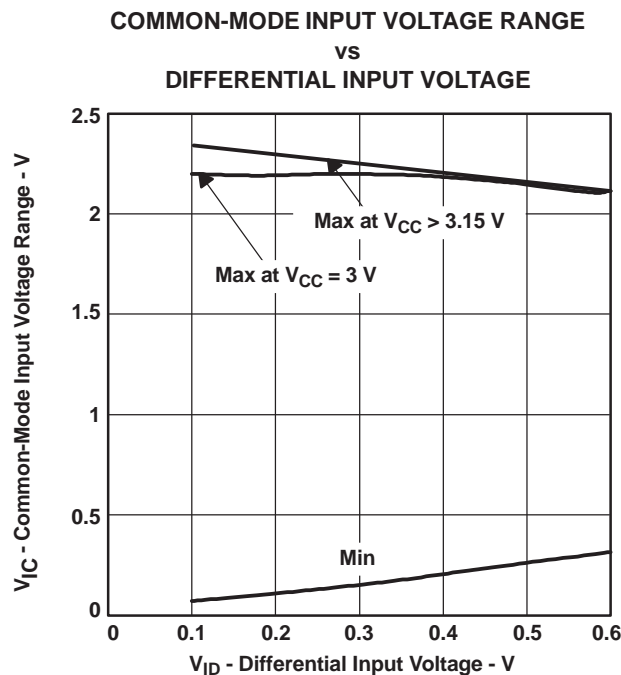

Figure 1. V_{IC} Versus V_{ID} and V_{CC}

SN55LVDS32 ELECTRICAL CHARACTERISTICS

over recommended operating conditions (unless otherwise noted)

PARAMETER	TEST CONDITIONS	MIN	TYP ⁽¹⁾	MAX	UNIT
V _{ITH+} Positive-going differential input voltage threshold	See Figure 2, Table 2, and ⁽²⁾			100	mV
V _{ITH-} Negative-going differential input voltage threshold ⁽³⁾	See Figure 2, Table 2, and ⁽²⁾	-100			mV
V _{OH} High-level output voltage	I _{OH} = -8 mA	2.4			V
V _{OL} Low-level output voltage	I _{OL} = 8 mA			0.4	V
I _{CC} Supply current	Enabled, No load		10	18	mA
	Disabled		0.25	0.5	
I _I Input current (A or B inputs)	V _I = 0	-2	-10	-20	μA
	V _I = 2.4 V	-1.2	-3		
I _{I(OFF)} Power-off input current (A or B inputs)	V _{CC} = 0, V _I = 2.4 V		6	20	μA
I _{IH} High-level input current (EN, G, or \overline{G} inputs)	V _{IH} = 2 V			10	μA
I _{IL} Low-level input current (EN, G, or \overline{G} inputs)	V _{IL} = 0.8 V			10	μA
I _{OZ} High-impedance output current	V _O = 0 or V _{CC}			±12	μA

(1) All typical values are at T_A = 25°C and with V_{CC} = 3.3 V.

(2) |V_{ITH}| = 200 mV for operation at -55°C

(3) The algebraic convention, in which the less-positive (more-negative) limit is designated minimum, is used in this data sheet for the negative-going differential input voltage threshold only.

SN55LVDS32 SWITCHING CHARACTERISTICS

over recommended operating conditions (unless otherwise noted)

PARAMETER	TEST CONDITIONS	MIN	TYP	MAX	UNIT
t _{PLH} Propagation delay time, low-to-high-level output	C _L = 10 pF, See Figure 3	1.3	2.3	6	ns
t _{PHL} Propagation delay time, high-to-low-level output		1.4	2.2	6.1	ns
t _{sk(o)} Channel-to-channel output skew ⁽¹⁾			0.1		ns
t _r Output signal rise time, 20% to 80%				0.6	ns
t _f Output signal fall time, 80% to 20%				0.7	ns
t _{PHZ} Propagation delay time, high-level-to-high-impedance output	See Figure 4		6.5	12	ns
t _{PLZ} Propagation delay time, low-level-to-high-impedance output			5.5	12	ns
t _{PZH} Propagation delay time, high-impedance-to-high-level output			8	14	ns
t _{PZL} Propagation delay time, high-impedance-to-low-level output			3	12	ns

(1) t_{sk(o)} is the maximum delay time difference between drivers on the same device.

SN65LVDSxxxx ELECTRICAL CHARACTERISTICS

over recommended operating conditions (unless otherwise noted)

PARAMETER		TEST CONDITIONS	SN65LVDS32 SN65LVDS3486 SN65LVDS9637			UNIT	
			MIN	TYP ⁽¹⁾	MAX		
V _{IT+}	Positive-going differential input voltage threshold	See Figure 2 and Table 2			100	mV	
V _{IT-}	Negative-going differential input voltage threshold ⁽²⁾	See Figure 2 and Table 2	-100			mV	
V _{OH}	High-level output voltage	I _{OH} = -8 mA	2.4			V	
		I _{OH} = -4 mA	2.8				
V _{OL}	Low-level output voltage	I _{OL} = 8 mA			0.4	V	
I _{CC}	Supply current	SN65LVDS32, SN65LVDS3486	Enabled, No load		10	18	mA
			Disabled		0.25	0.5	
		SN65LVDS9637	No load		5.5	10	
I _I	Input current (A or B inputs)	V _I = 0	-2	-10	-20	μA	
		V _I = 2.4 V	-1.2	-3			
I _{I(OFF)}	Power-off input current (A or B inputs)	V _{CC} = 0, V _I = 3.6 V	6	20		μA	
I _{IH}	High-level input current (EN, G, or \overline{G} inputs)	V _{IH} = 2 V			10	μA	
I _{IL}	Low-level input current (EN, G, or \overline{G} inputs)	V _{IL} = 0.8 V			10	μA	
I _{OZ}	High-impedance output current	V _O = 0 or V _{CC}			±10	μA	

(1) All typical values are at T_A = 25°C and with V_{CC} = 3.3 V.

(2) The algebraic convention, in which the less-positive (more-negative) limit is designated minimum, is used in this data sheet for the negative-going differential input voltage threshold only.

SN65LVDSxxxx SWITCHING CHARACTERISTICS

over recommended operating conditions (unless otherwise noted)

PARAMETER		TEST CONDITIONS	SN65LVDS32 SN65LVDS3486 SN65LVDS9637			UNIT
			MIN	TYP	MAX	
t _{PLH}	Propagation delay time, low-to-high-level output	C _L = 10 pF, See Figure 3	1.5	2.1	3	ns
t _{PHL}	Propagation delay time, high-to-low-level output		1.5	2.1	3	ns
t _{sk(p)}	Pulse skew (t _{PHL} - t _{PLH})			0	0.4	ns
t _{sk(o)}	Channel-to-channel output skew ⁽¹⁾			0.1	0.3	ns
t _{sk(pp)}	Part-to-part skew ⁽²⁾				1	ns
t _r	Output signal rise time, 20% to 80%			0.6		ns
t _f	Output signal fall time, 80% to 20%			0.7		ns
t _{PHZ}	Propagation delay time, high-level-to-high-impedance output	See Figure 4		6.5	12	ns
t _{PLZ}	Propagation delay time, low-level-to-high-impedance output			5.5	12	ns
t _{PZH}	Propagation delay time, high-impedance-to-high-level output			8	12	ns
t _{PZL}	Propagation delay time, high-impedance-to-low-level output			3	12	ns

(1) t_{sk(o)} is the skew between specified outputs of a single device with all driving inputs connected together and the outputs switching in the same direction while driving identical specified loads.

(2) t_{sk(pp)} is the magnitude of the difference in propagation delay times between any specified terminals of two devices when both devices operate with the same supply voltages, same temperature, and have identical packages and test circuits.

PARAMETER MEASUREMENT INFORMATION

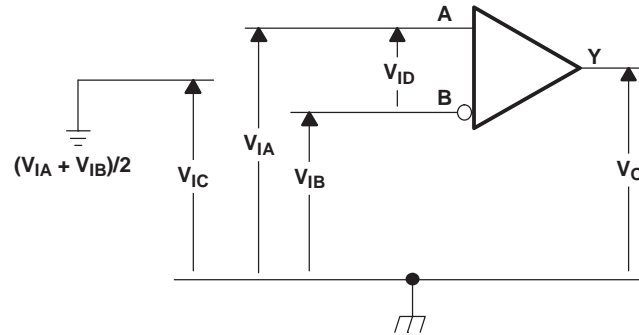
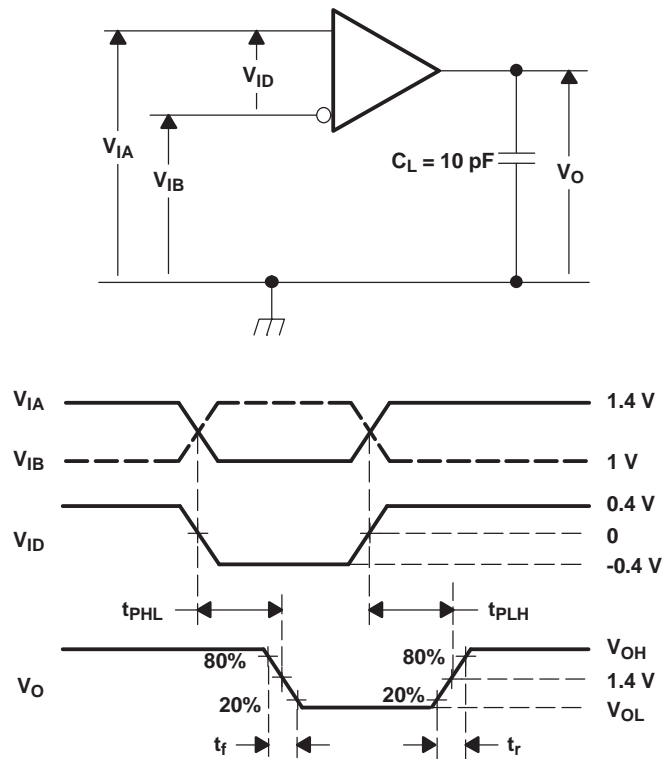

Figure 2. Voltage Definitions

Table 2. Receiver Minimum and Maximum Input Threshold Test Voltages

Applied Voltages		Resulting Differential Input Voltage	Resulting Common-Mode Input Voltage
V _{IA} (V)	V _{IB} (V)	V _{ID} (mV)	V _{IC} (V)
1.25	1.15	100	1.2
1.15	1.25	-100	1.2
2.4	2.3	100	2.35
2.3	2.4	-100	2.35
0.1	0	100	0.05
0	0.1	-100	0.05
1.5	0.9	600	1.2
0.9	1.5	-600	1.2
2.4	1.8	600	2.1
1.8	2.4	-600	2.1
0.6	0	600	0.3
0	0.6	-600	0.3



- A. All input pulses are supplied by a generator having the following characteristics: t_r or $t_f \leq 1 \text{ ns}$, pulse repetition rate (PRR) = 50 Mpps, pulse width = $10 \pm 0.2 \text{ ns}$.
- B. C_L includes instrumentation and fixture capacitance within 6 mm of the D.U.T.

Figure 3. Timing Test Circuit and Waveforms

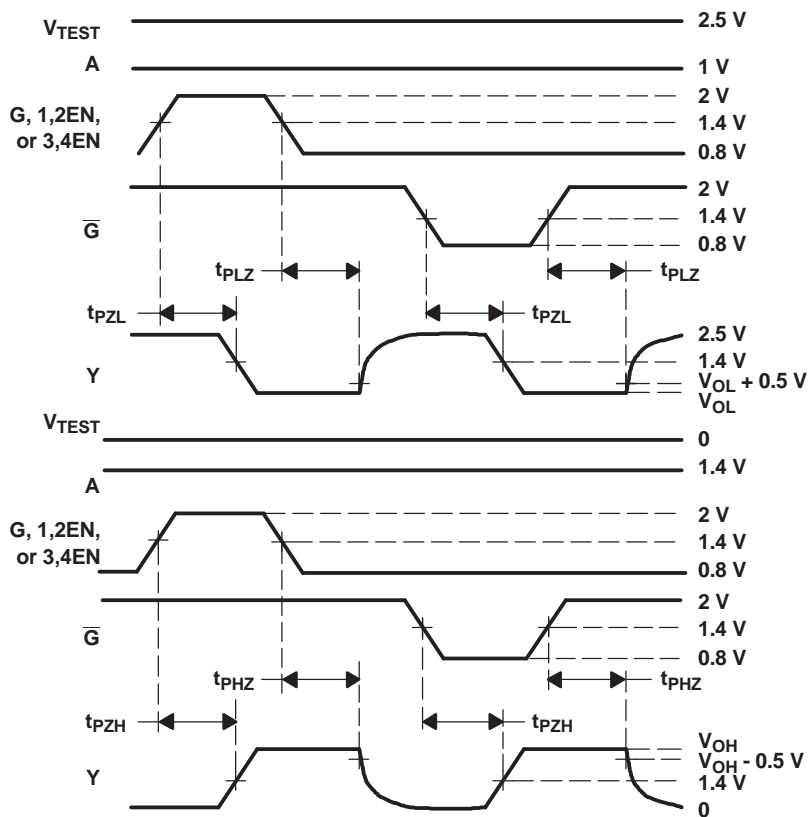
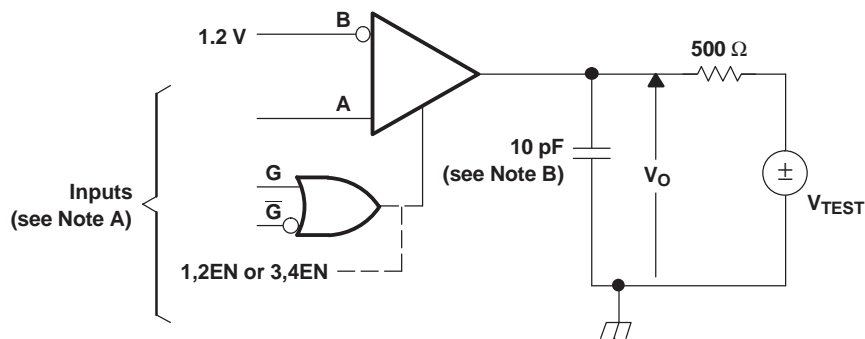

- A. All input pulses are supplied by a generator having the following characteristics: t_r or $t_f \leq 1$ ns, pulse repetition rate (PRR) = 0.5 Mpps, pulse width = 500 ± 10 ns.
- B. C_L includes instrumentation and fixture capacitance within 6 mm of the D.U.T.

Figure 4. Enable- and Disable-Time Test Circuit and Waveforms

TYPICAL CHARACTERISTICS

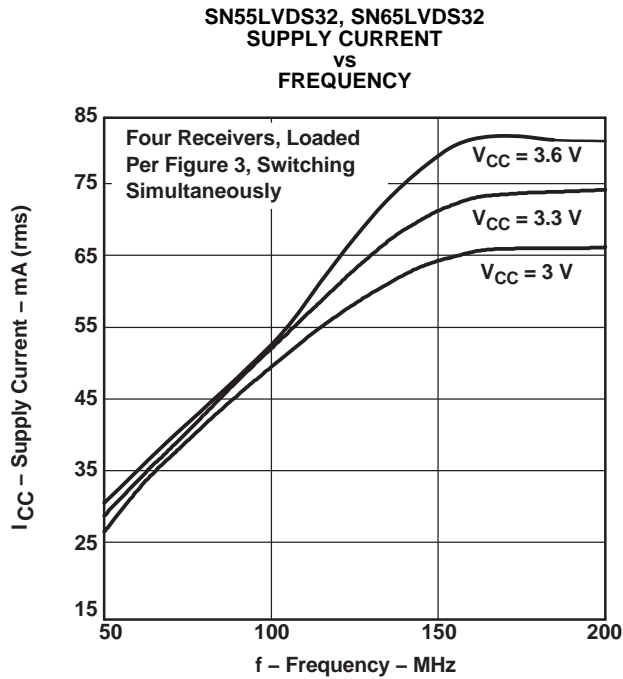

Figure 5.

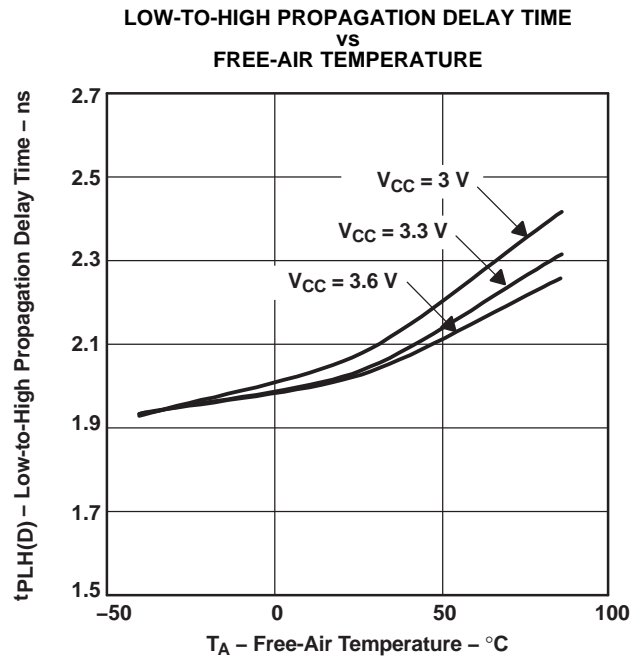

Figure 6.

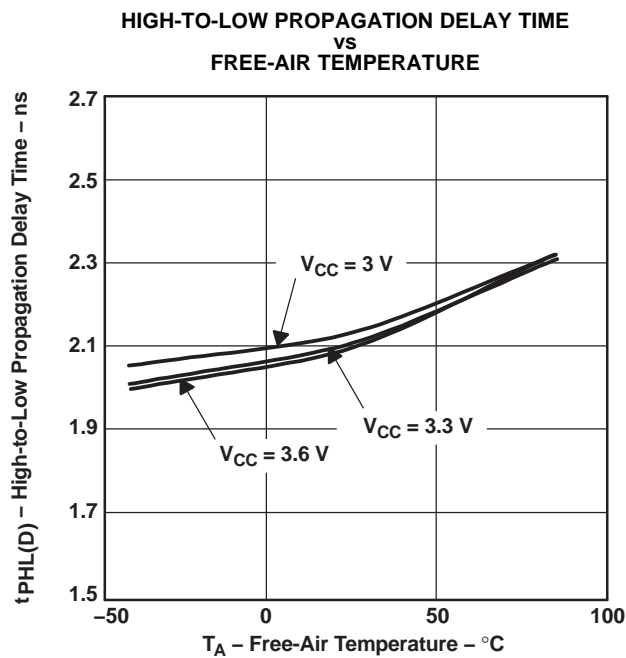

Figure 7.

TYPICAL CHARACTERISTICS (continued)

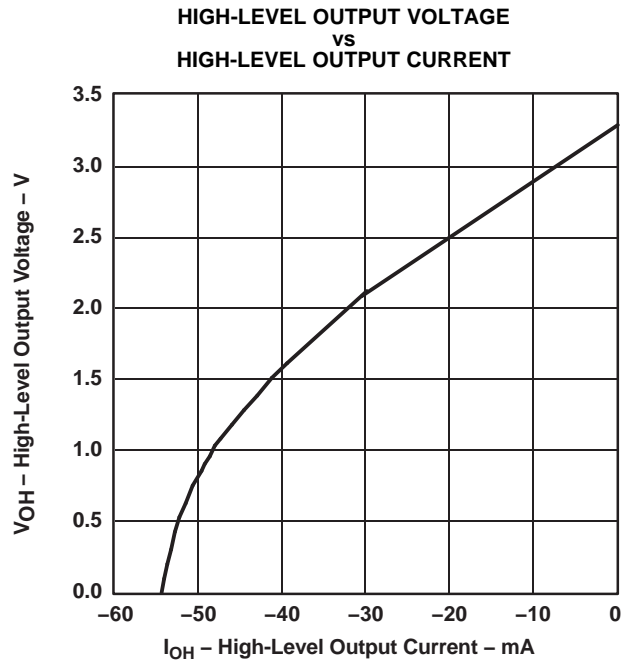

Figure 8.

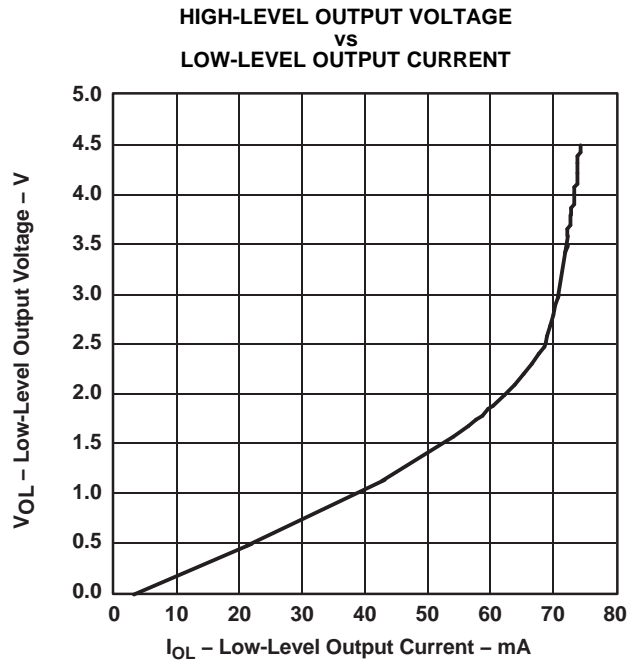

Figure 9.

APPLICATION INFORMATION

Equipment

- Hewlett Packard HP6624A DC power supply
- Tektronix TDS7404 Real Time Scope
- Agilent ParBERT E4832A

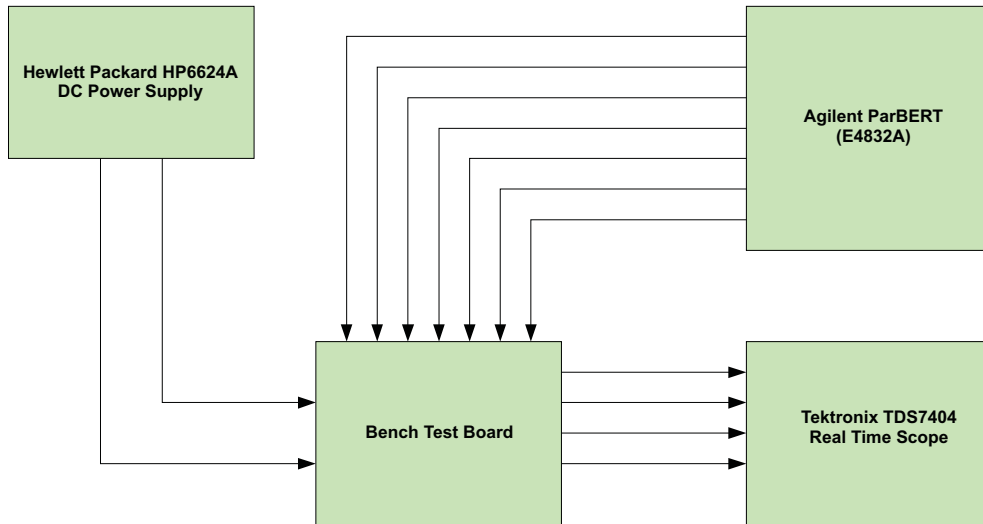
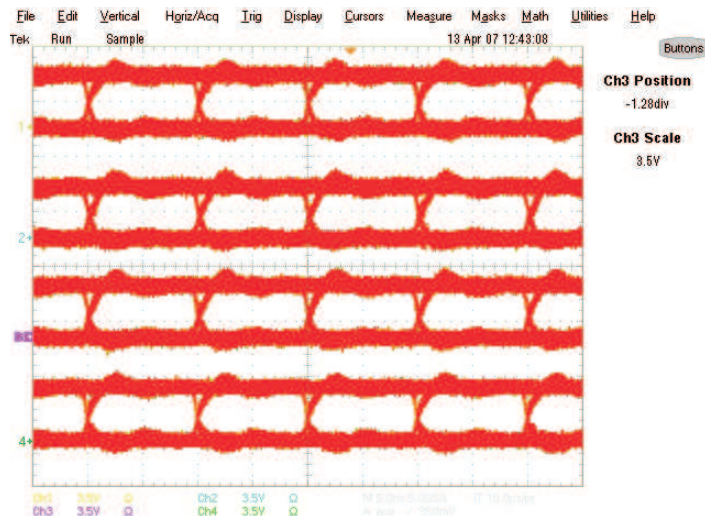

Figure 10. Equipment Setup



All Rx running at 100 Mbps; Channel 1: 1Y, Channel 2: 2Y; Channel 3: 3Y; Channel 4: 4Y

Figure 11. Typical Eye Patterns SN65LVDS32: (T = 25°C; V_{CC} = 3.6 V; PRBS = 2²³-1)

APPLICATION INFORMATION (continued)

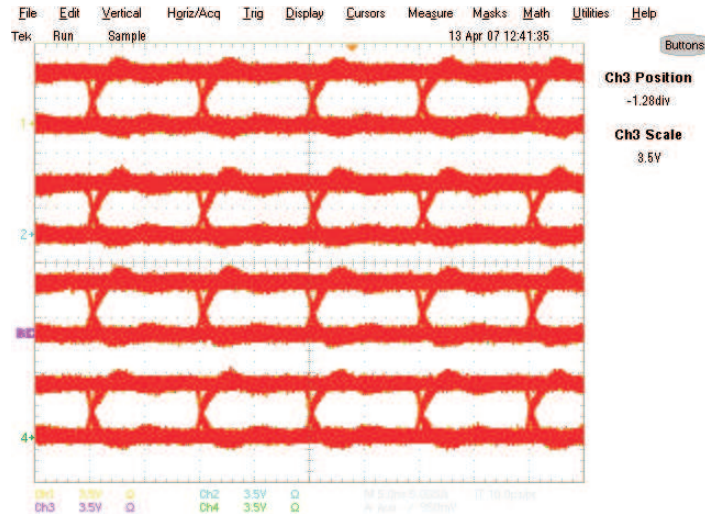

All Rx running at 100 Mbps; Channel 1: 1Y, Channel 2: 2Y; Channel 3: 3Y; Channel 4: 4Y

Figure 12. Typical Eye Patterns SN65LVDS3486: (T = 25°C; V_{CC} = 3.6 V; PRBS = 2²³-1)

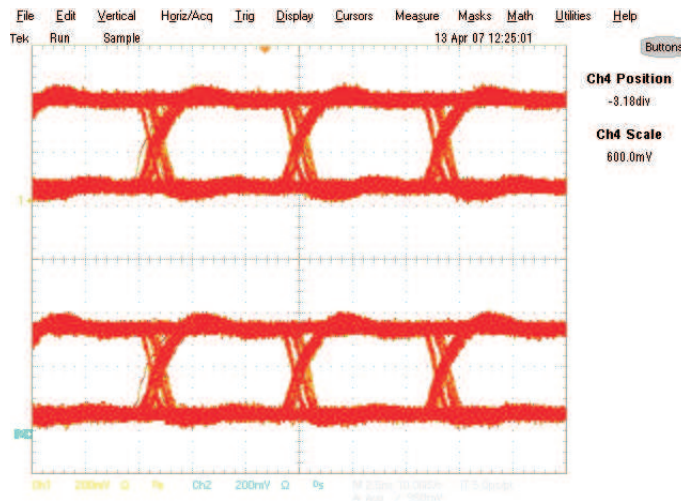

All Rx running at 150 Mbps; Channel 1: 1Y, Channel 2: 2Y

Figure 13. Typical Eye Patterns SN65LVDS9637: (T = 25°C; V_{CC} = 3.6 V; PRBS = 2²³-1)

APPLICATION INFORMATION (continued)

USING AN LVDS RECEIVER WITH RS-422 DATA

Receipt of data from a TIA/EIA-422 line driver can be accomplished using a TIA/EIA-644 line receiver with the addition of an attenuator circuit. This technique gives the user a high-speed and low-power 422 receiver.

If the ground noise between the transmitter and receiver is not a concern (less than ± 1 V), the answer can be as simple as shown in Figure 14. A resistor divider circuit in front of the LVDS receiver attenuates the 422 differential signal to LVDS levels.

The resistors present a total differential load of $100\ \Omega$ to match the characteristic impedance of the transmission line and to reduce the signal 10:1. The maximum 422 differential output signal, or 6 V, is reduced to 600 mV. The high input impedance of the LVDS receiver prevents input bias offsets and maintains a greater than 200-mV differential input voltage threshold at the inputs to the divider. This circuit is used in front of each LVDS channel that also receives 422 signals.

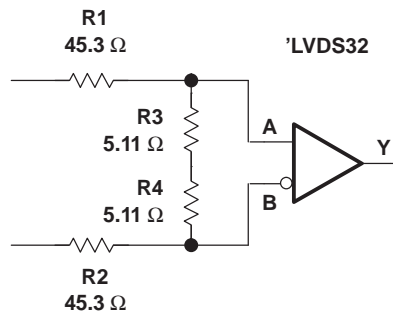

NOTE: The components used were standard values. (1) R1, R2 = NRC12F45R3TR, NIC components, 45.3 Ω, 1/8 W, 1%, 1206 package (2) R3, R4 = NRC12F5R11TR, NIC components, 5.11 Ω, 1/8 W, 1%, 1206 package (3) The resistor values do not need to be 1% tolerance. However, it can be difficult locating a supplier of resistors having values less than 100 Ω in stock and readily available. The user may find other suppliers with comparable parts having tolerances of 5% or even 10%. These parts are adequate for use in this circuit.

Figure 14. RS-422 Data Input to an LVDS Receiver Under Low Ground-Noise Conditions

If ground noise between the RS-422 driver and LVDS receiver is a concern, the common-mode voltage must be attenuated. The circuit must then be modified to connect the node between R3 and R4 to the LVDS receiver ground. This modification to the circuit increases the common-mode voltage from ± 1 V to greater than ± 4.5 V.

The devices are generally used as building blocks for high-speed point-to-point data transmission where ground differences are less than 1 V. Devices can interoperate with RS-422, PECL, and IEEE-P1596. Drivers/receivers approach ECL speeds without the power and dual-supply requirements.

APPLICATION INFORMATION (continued)

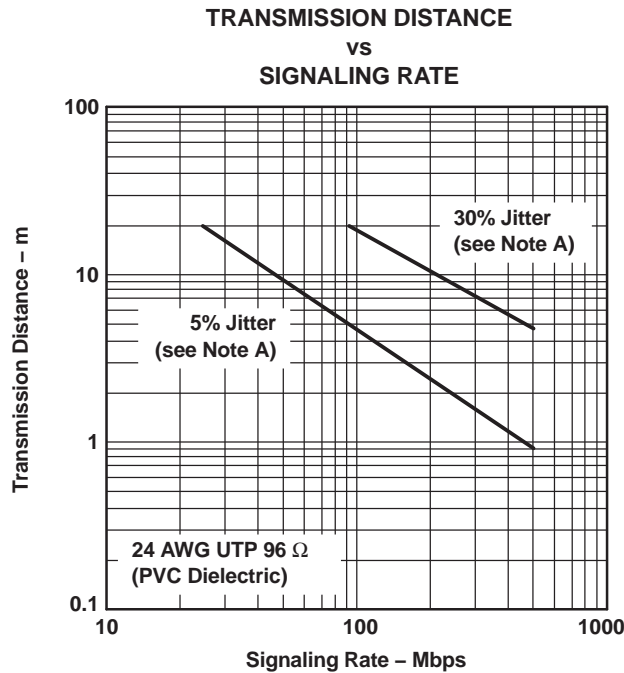

- A. This parameter is the percentage of distortion of the unit interval (UI) with a pseudorandom data pattern.

Figure 15. Typical Transmission Distance Versus Signaling Rate

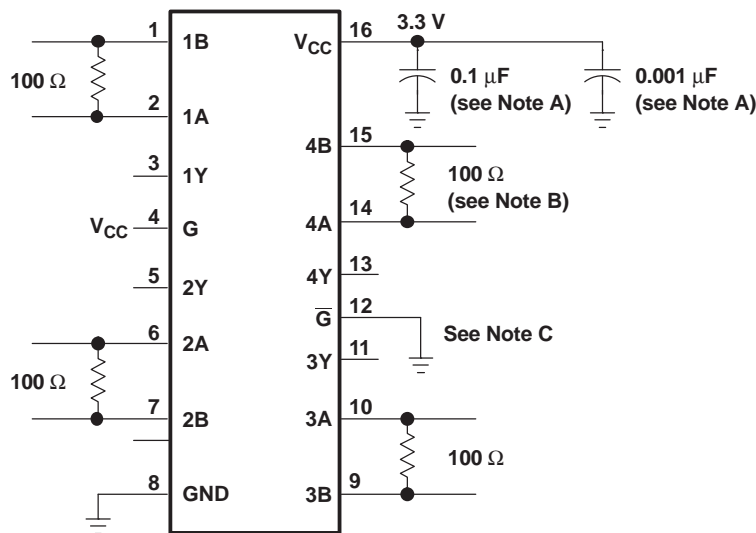

- A. Place a 0.1- μ F and a 0.001- μ F Z5U ceramic, mica, or polystyrene dielectric, 0805 size, chip capacitor between V_{CC} and the ground plane. The capacitors should be located as close as possible to the device terminals.
- B. The termination resistance value should match the nominal characteristic impedance of the transmission media with $\pm 10\%$.
- C. Unused enable inputs should be tied to V_{CC} or GND as appropriate.

Figure 16. Typical Application Circuit Schematic

APPLICATION INFORMATION

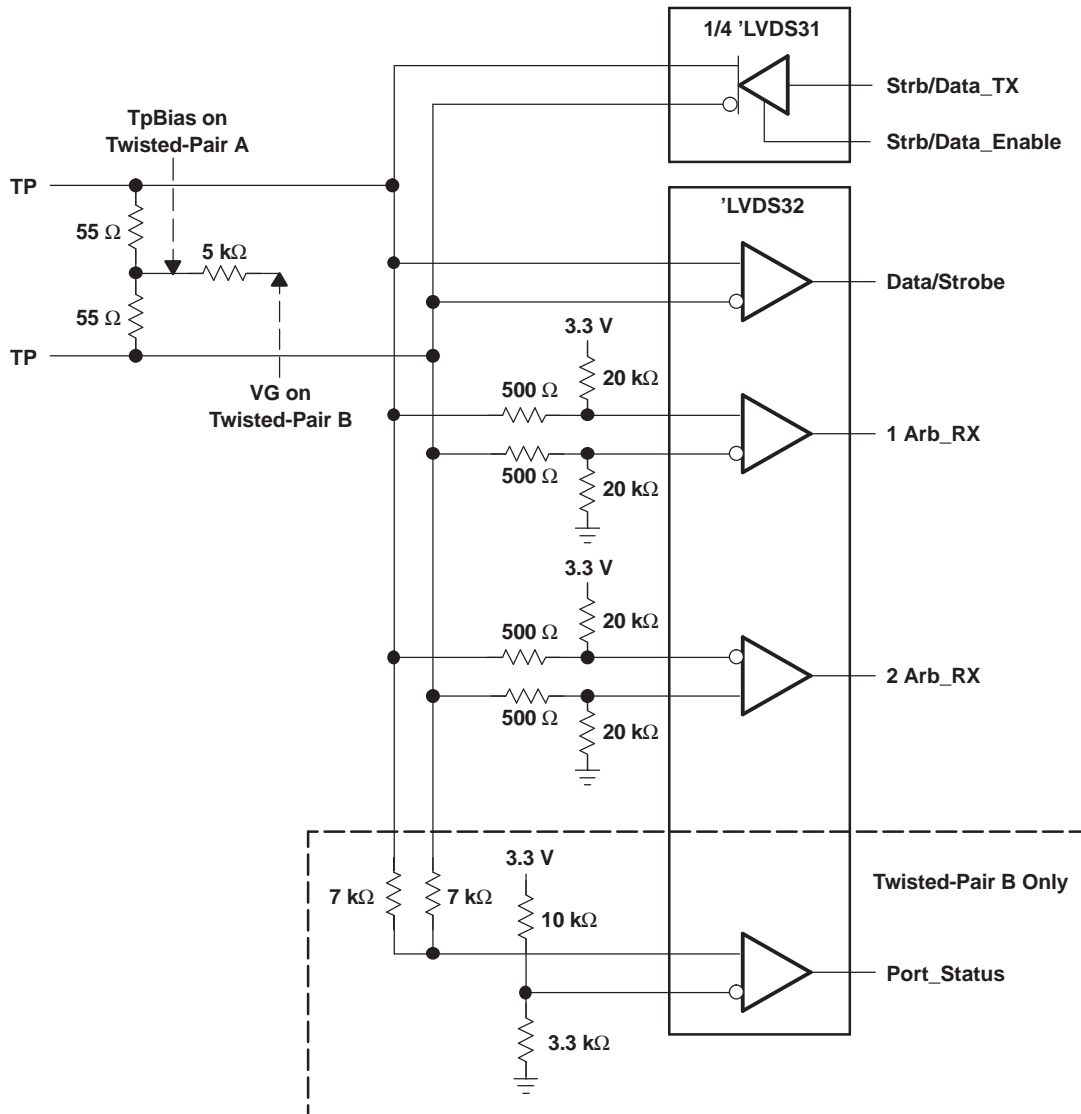

- A. Resistors are leadless, thick film (0603), 5% tolerance.
- B. Decoupling capacitance is not shown but recommended.
- C. V_{CC} is 3 V to 3.6 V.
- D. The differential output voltage of the 'LVDS31 can exceed that allowed by IEEE1394.

Figure 17. 100-Mbps IEEE 1394 Transceiver

FAIL-SAFE

One of the most common problems with differential signaling applications is how the system responds when no differential voltage is present on the signal pair. The LVDS receiver is like most differential line receivers in that its output logic state can be indeterminate when the differential input voltage is between -100 mV and 100 mV if it is within its recommended input common-mode voltage range. However, TI LVDS receivers handle the open-input circuit situation differently.

APPLICATION INFORMATION (continued)

Open-input circuit means that there is little or no input current to the receiver from the data line itself. This could be when the driver is in a high-impedance state or the cable is disconnected. When this occurs, the LVDS receiver pulls each line of the signal pair to near V_{CC} through 300-k Ω resistors (see Figure 18). The fail-safe feature uses an AND gate with input voltage thresholds at about 2.3 V to detect this condition and force the output to a high level, regardless of the differential input voltage.

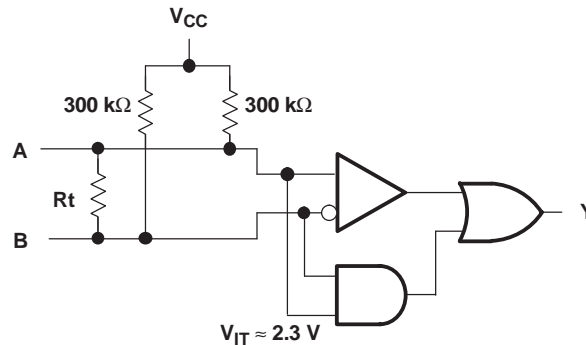
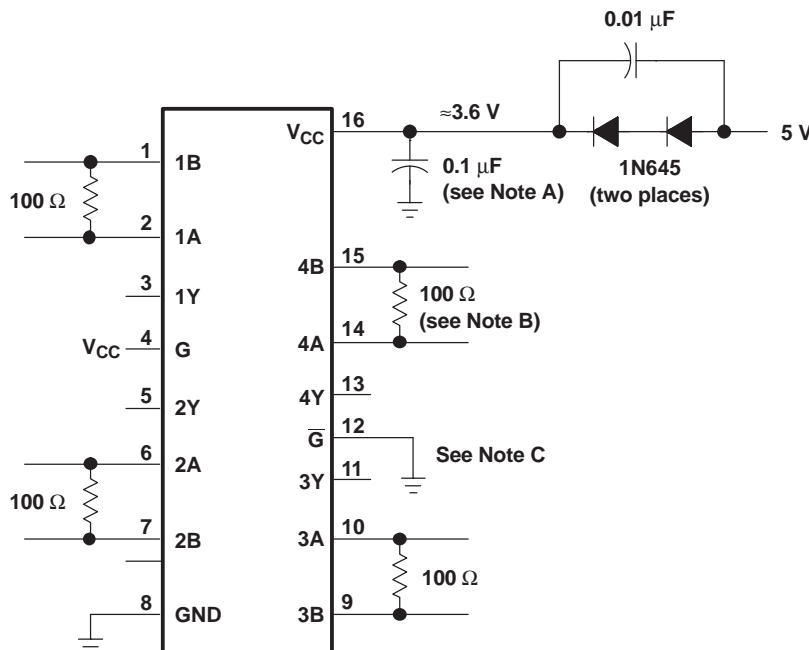

Figure 18. Open-Circuit Fail-Safe of LVDS Receiver

It is only under these conditions that the output of the receiver is valid with less than a 100-mV differential input voltage magnitude. The presence of the termination resistor, R_t , does not affect the fail-safe function as long as it is connected as shown in Figure 18. Other termination circuits may allow a dc current to ground that could defeat the pullup currents from the receiver and the fail-safe feature.



- Place a 0.1- μ F Z5U ceramic, mica, or polystyrene dielectric, 0805 size, chip capacitor between V_{CC} and the ground plane. The capacitor should be located as close as possible to the device terminals.
- The termination resistance value should match the nominal characteristic impedance of the transmission media with $\pm 10\%$.
- Unused enable inputs should be tied to V_{CC} or GND, as appropriate.

Figure 19. Operation With 5-V Supply

APPLICATION INFORMATION (continued)

COLD SPARING

Systems using cold sparing have a redundant device electrically connected without power supplied. To support this configuration, the spare must present a high-input impedance to the system so that it does not draw appreciable power. In cold sparing, voltage may be applied to an I/O before and during power up of a device. When the device is powered off, V_{CC} must be clamped to ground and the I/O voltages applied must be within the specified recommended operating conditions.

RELATED INFORMATION

IBIS modeling is available for this device. Contact the local TI sales office or the TI Web site at www.ti.com for more information.

For more application guidelines, see the following documents:

- *Low-Voltage Differential Signaling Design Notes (SLLA014)*
- *Interface Circuits for TIA/EIA-644 (LVDS) (SLLA038)*
- *Reducing EMI With LVDS (SLLA030)*
- *Slew Rate Control of LVDS Circuits (SLLA034)*
- *Using an LVDS Receiver With TIA/EIA-422 Data (SLLA031)*
- *Low Voltage Differential Signaling (LVDS) EVM (SLLA033)*

PACKAGING INFORMATION

Orderable Device	Status ⁽¹⁾	Package Type	Package Drawing	Pins	Package Qty	Eco Plan ⁽²⁾	Lead/Ball Finish	MSL Peak Temp ⁽³⁾
5962-9762201Q2A	ACTIVE	LCCC	FK	20	1	TBD	POST-PLATE	N / A for Pkg Type
5962-9762201QEA	ACTIVE	CDIP	J	16	1	TBD	A42 SNPB	N / A for Pkg Type
5962-9762201QFA	ACTIVE	CFP	W	16	1	TBD	A42 SNPB	N / A for Pkg Type
5962-9762201VF A	ACTIVE	CFP	W	16	1	TBD	A42 SNPB	N / A for Pkg Type
5962-9762202Q2A	ACTIVE	LCCC	FK	20	1	TBD	POST-PLATE	N / A for Pkg Type
SN55LVDS32W	ACTIVE	CFP	W	16	1	TBD	A42 SNPB	N / A for Pkg Type
SN65LVDS32D	ACTIVE	SOIC	D	16	40	Green (RoHS & no Sb/Br)	CU NIPDAU	Level-1-260C-UNLIM
SN65LVDS32DG4	ACTIVE	SOIC	D	16	40	Green (RoHS & no Sb/Br)	CU NIPDAU	Level-1-260C-UNLIM
SN65LVDS32DR	ACTIVE	SOIC	D	16	2500	Green (RoHS & no Sb/Br)	CU NIPDAU	Level-1-260C-UNLIM
SN65LVDS32DRG4	ACTIVE	SOIC	D	16	2500	Green (RoHS & no Sb/Br)	CU NIPDAU	Level-1-260C-UNLIM
SN65LVDS32NSR	ACTIVE	SO	NS	16	2000	Green (RoHS & no Sb/Br)	CU NIPDAU	Level-1-260C-UNLIM
SN65LVDS32NSRG4	ACTIVE	SO	NS	16	2000	Green (RoHS & no Sb/Br)	CU NIPDAU	Level-1-260C-UNLIM
SN65LVDS32PW	ACTIVE	TSSOP	PW	16	90	Green (RoHS & no Sb/Br)	CU NIPDAU	Level-1-260C-UNLIM
SN65LVDS32PWG4	ACTIVE	TSSOP	PW	16	90	Green (RoHS & no Sb/Br)	CU NIPDAU	Level-1-260C-UNLIM
SN65LVDS32PWR	ACTIVE	TSSOP	PW	16	2000	Green (RoHS & no Sb/Br)	CU NIPDAU	Level-1-260C-UNLIM
SN65LVDS32PW RG4	ACTIVE	TSSOP	PW	16	2000	Green (RoHS & no Sb/Br)	CU NIPDAU	Level-1-260C-UNLIM
SN65LVDS3486D	ACTIVE	SOIC	D	16	40	Green (RoHS & no Sb/Br)	CU NIPDAU	Level-1-260C-UNLIM
SN65LVDS3486DG4	ACTIVE	SOIC	D	16	40	Green (RoHS & no Sb/Br)	CU NIPDAU	Level-1-260C-UNLIM
SN65LVDS3486DR	ACTIVE	SOIC	D	16	2500	Green (RoHS & no Sb/Br)	CU NIPDAU	Level-1-260C-UNLIM
SN65LVDS3486DRG4	ACTIVE	SOIC	D	16	2500	Green (RoHS & no Sb/Br)	CU NIPDAU	Level-1-260C-UNLIM
SN65LVDS9637D	ACTIVE	SOIC	D	8	75	Green (RoHS & no Sb/Br)	CU NIPDAU	Level-1-260C-UNLIM
SN65LVDS9637DG4	ACTIVE	SOIC	D	8	75	Green (RoHS & no Sb/Br)	CU NIPDAU	Level-1-260C-UNLIM
SN65LVDS9637DGK	ACTIVE	MSOP	DGK	8	80	Green (RoHS & no Sb/Br)	CU NIPDAU	Level-1-260C-UNLIM
SN65LVDS9637DGKG4	ACTIVE	MSOP	DGK	8	80	Green (RoHS & no Sb/Br)	CU NIPDAU	Level-1-260C-UNLIM
SN65LVDS9637DGKR	ACTIVE	MSOP	DGK	8	2500	Green (RoHS & no Sb/Br)	CU NIPDAU	Level-1-260C-UNLIM
SN65LVDS9637DGKRG4	ACTIVE	MSOP	DGK	8	2500	Green (RoHS & no Sb/Br)	CU NIPDAU	Level-1-260C-UNLIM
SN65LVDS9637DGN	ACTIVE	MSOP-Power PAD	DGN	8	80	Green (RoHS & no Sb/Br)	CU NIPDAU	Level-1-260C-UNLIM

Orderable Device	Status ⁽¹⁾	Package Type	Package Drawing	Pins	Package Qty	Eco Plan ⁽²⁾	Lead/Ball Finish	MSL Peak Temp ⁽³⁾
SN65LVDS9637DGNG4	ACTIVE	MSOP-Power PAD	DGN	8	80	Green (RoHS & no Sb/Br)	CU NIPDAU	Level-1-260C-UNLIM
SN65LVDS9637DGNR	ACTIVE	MSOP-Power PAD	DGN	8	2500	Green (RoHS & no Sb/Br)	CU NIPDAU	Level-1-260C-UNLIM
SN65LVDS9637DGNRG4	ACTIVE	MSOP-Power PAD	DGN	8	2500	Green (RoHS & no Sb/Br)	CU NIPDAU	Level-1-260C-UNLIM
SN65LVDS9637DR	ACTIVE	SOIC	D	8	2500	Green (RoHS & no Sb/Br)	CU NIPDAU	Level-1-260C-UNLIM
SN65LVDS9637DRG4	ACTIVE	SOIC	D	8	2500	Green (RoHS & no Sb/Br)	CU NIPDAU	Level-1-260C-UNLIM
SNJ55LVDS32FK	ACTIVE	LCCC	FK	20	1	TBD	POST-PLATE	N / A for Pkg Type
SNJ55LVDS32J	ACTIVE	CDIP	J	16	1	TBD	A42 SNPB	N / A for Pkg Type
SNJ55LVDS32W	ACTIVE	CFP	W	16	1	TBD	A42 SNPB	N / A for Pkg Type

⁽¹⁾ The marketing status values are defined as follows:

ACTIVE: Product device recommended for new designs.

LIFEBUY: TI has announced that the device will be discontinued, and a lifetime-buy period is in effect.

NRND: Not recommended for new designs. Device is in production to support existing customers, but TI does not recommend using this part in a new design.

PREVIEW: Device has been announced but is not in production. Samples may or may not be available.

OBSOLETE: TI has discontinued the production of the device.

⁽²⁾ Eco Plan - The planned eco-friendly classification: Pb-Free (RoHS), Pb-Free (RoHS Exempt), or Green (RoHS & no Sb/Br) - please check <http://www.ti.com/productcontent> for the latest availability information and additional product content details.

TBD: The Pb-Free/Green conversion plan has not been defined.

Pb-Free (RoHS): TI's terms "Lead-Free" or "Pb-Free" mean semiconductor products that are compatible with the current RoHS requirements for all 6 substances, including the requirement that lead not exceed 0.1% by weight in homogeneous materials. Where designed to be soldered at high temperatures, TI Pb-Free products are suitable for use in specified lead-free processes.

Pb-Free (RoHS Exempt): This component has a RoHS exemption for either 1) lead-based flip-chip solder bumps used between the die and package, or 2) lead-based die adhesive used between the die and leadframe. The component is otherwise considered Pb-Free (RoHS compatible) as defined above.

Green (RoHS & no Sb/Br): TI defines "Green" to mean Pb-Free (RoHS compatible), and free of Bromine (Br) and Antimony (Sb) based flame retardants (Br or Sb do not exceed 0.1% by weight in homogeneous material)

⁽³⁾ MSL, Peak Temp. -- The Moisture Sensitivity Level rating according to the JEDEC industry standard classifications, and peak solder temperature.

Important Information and Disclaimer: The information provided on this page represents TI's knowledge and belief as of the date that it is provided. TI bases its knowledge and belief on information provided by third parties, and makes no representation or warranty as to the accuracy of such information. Efforts are underway to better integrate information from third parties. TI has taken and continues to take reasonable steps to provide representative and accurate information but may not have conducted destructive testing or chemical analysis on incoming materials and chemicals. TI and TI suppliers consider certain information to be proprietary, and thus CAS numbers and other limited information may not be available for release.

In no event shall TI's liability arising out of such information exceed the total purchase price of the TI part(s) at issue in this document sold by TI to Customer on an annual basis.

TAPE AND REEL INFORMATION

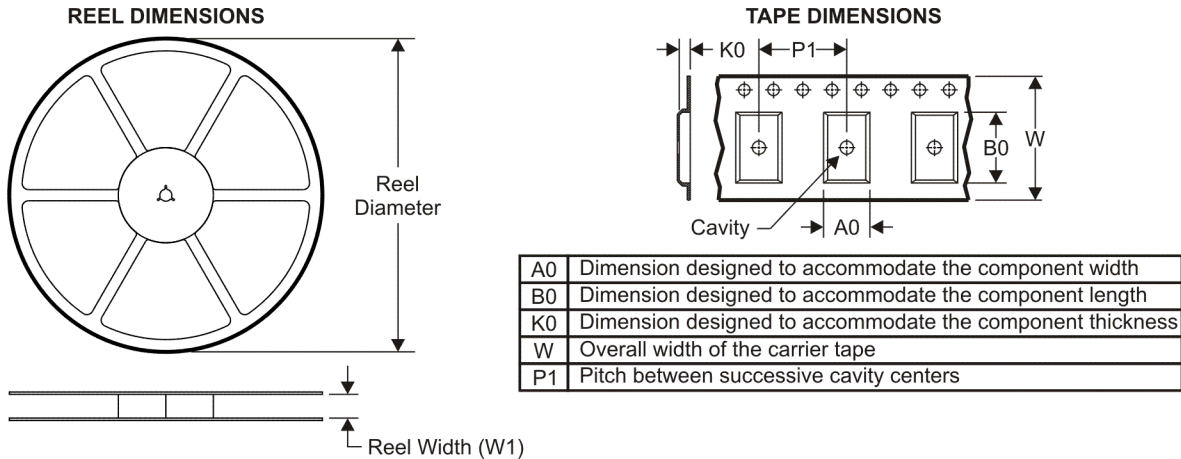

QUADRANT ASSIGNMENTS FOR PIN 1 ORIENTATION IN TAPE

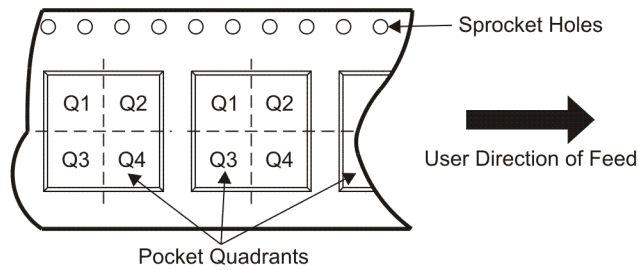

*All dimensions are nominal

Device	Package Type	Package Drawing	Pins	SPQ	Reel Diameter (mm)	Reel Width W1 (mm)	A0 (mm)	B0 (mm)	K0 (mm)	P1 (mm)	W (mm)	Pin1 Quadrant
SN65LVDS32DR	SOIC	D	16	2500	330.0	16.4	6.5	10.3	2.1	8.0	16.0	Q1
SN65LVDS32NSR	SO	NS	16	2000	330.0	16.4	8.2	10.5	2.5	12.0	16.0	Q1
SN65LVDS32PWR	TSSOP	PW	16	2000	330.0	12.4	6.67	5.4	1.6	8.0	12.0	Q1
SN65LVDS3486DR	SOIC	D	16	2500	330.0	16.4	6.5	10.3	2.1	8.0	16.0	Q1
SN65LVDS9637DGKR	MSOP	DGK	8	2500	330.0	12.4	5.3	3.4	1.4	8.0	12.0	Q1
SN65LVDS9637DGNR	MSOP-Power PAD	DGN	8	2500	330.0	12.4	5.3	3.4	1.4	8.0	12.0	Q1
SN65LVDS9637DR	SOIC	D	8	2500	330.0	12.4	6.4	5.2	2.1	8.0	12.0	Q1

TAPE AND REEL BOX DIMENSIONS

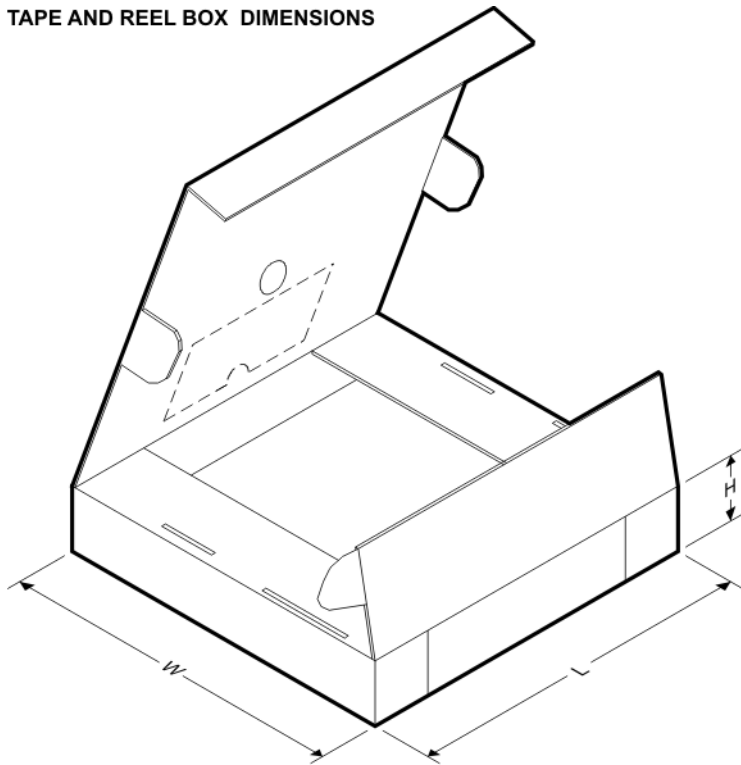

*All dimensions are nominal

Device	Package Type	Package Drawing	Pins	SPQ	Length (mm)	Width (mm)	Height (mm)
SN65LVDS32DR	SOIC	D	16	2500	342.9	345.9	28.6
SN65LVDS32NSR	SO	NS	16	2000	346.0	346.0	33.0
SN65LVDS32PWR	TSSOP	PW	16	2000	346.0	346.0	29.0
SN65LVDS3486DR	SOIC	D	16	2500	346.0	346.0	33.0
SN65LVDS9637DGKR	MSOP	DGK	8	2500	358.0	335.0	35.0
SN65LVDS9637DGNR	MSOP-PowerPAD	DGN	8	2500	358.0	335.0	35.0
SN65LVDS9637DR	SOIC	D	8	2500	346.0	346.0	29.0

DGN (S-PDSO-G8)

PowerPAD™ PLASTIC SMALL-OUTLINE PACKAGE

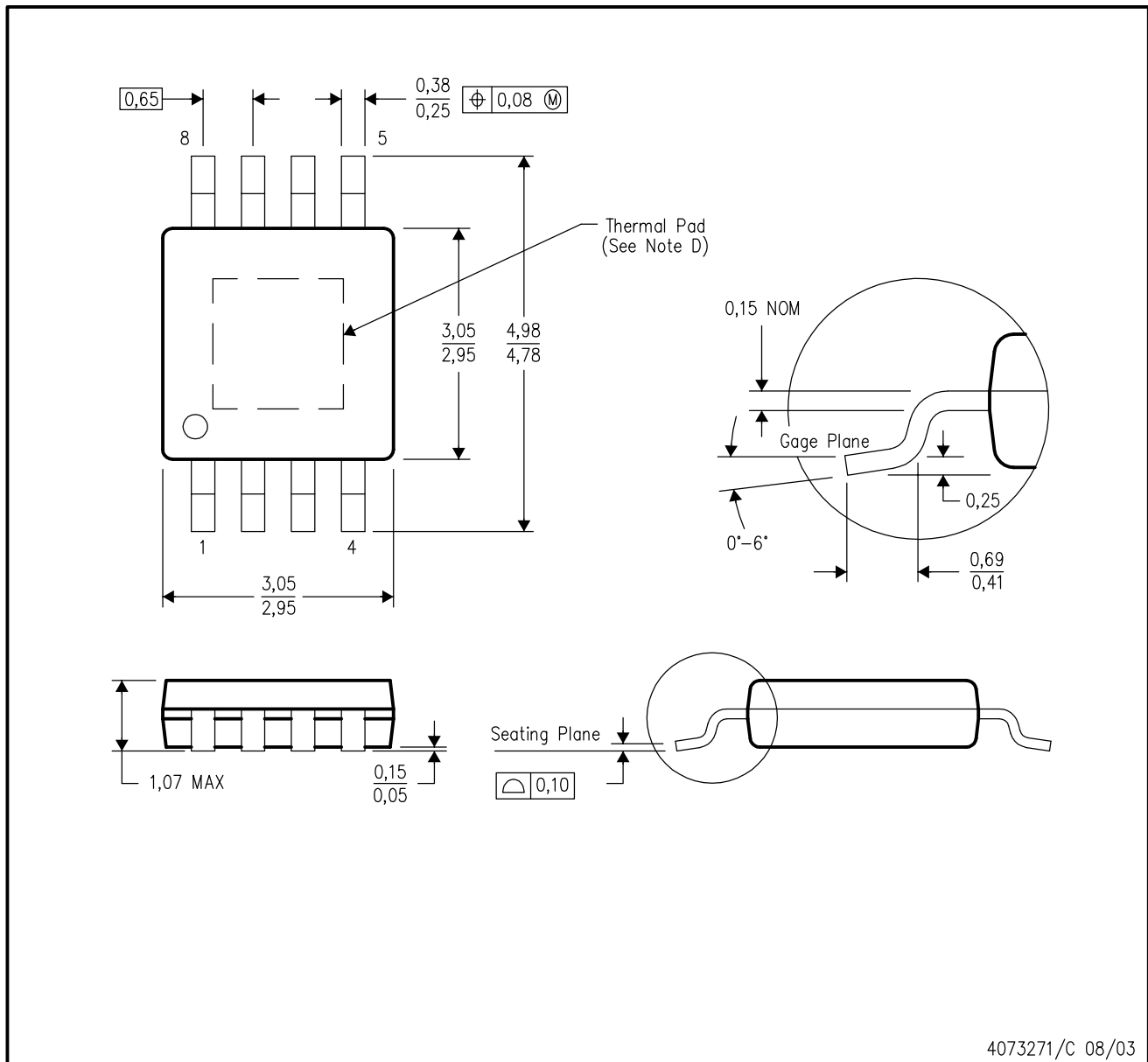

4073271/C 08/03

- NOTES:
- All linear dimensions are in millimeters.
 - This drawing is subject to change without notice.
 - Body dimensions do not include mold flash or protrusion.
 - This package is designed to be soldered to a thermal pad on the board. Refer to Technical Brief, PowerPad Thermally Enhanced Package, Texas Instruments Literature No. SLMA002 for information regarding recommended board layout. This document is available at www.ti.com <<http://www.ti.com>>.
 - Falls within JEDEC MO-187

PowerPAD is a trademark of Texas Instruments.

THERMAL INFORMATION

This PowerPAD™ package incorporates an exposed thermal pad that is designed to be attached directly to an external heatsink. The thermal pad must be soldered directly to the printed circuit board (PCB). After soldering, the PCB can be used as a heatsink. In addition, through the use of thermal vias, the thermal pad can be attached directly to the appropriate copper plane shown in the electrical schematic for the device, or alternatively, can be attached to a special heatsink structure designed into the PCB. This design optimizes the heat transfer from the integrated circuit (IC).

For additional information on the PowerPAD package and how to take advantage of its heat dissipating abilities, refer to Technical Brief, PowerPAD Thermally Enhanced Package, Texas Instruments Literature No. SLMA002 and Application Brief, PowerPAD Made Easy, Texas Instruments Literature No. SLMA004. Both documents are available at www.ti.com.

The exposed thermal pad dimensions for this package are shown in the following illustration.

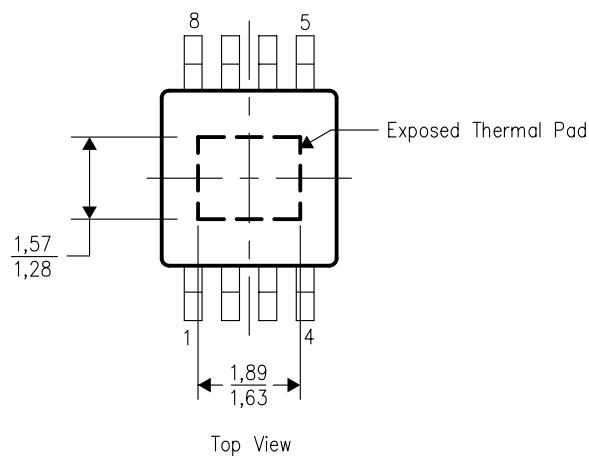

NOTE: All linear dimensions are in millimeters

Exposed Thermal Pad Dimensions

DGN (R-PDS0-G8) PowerPAD™

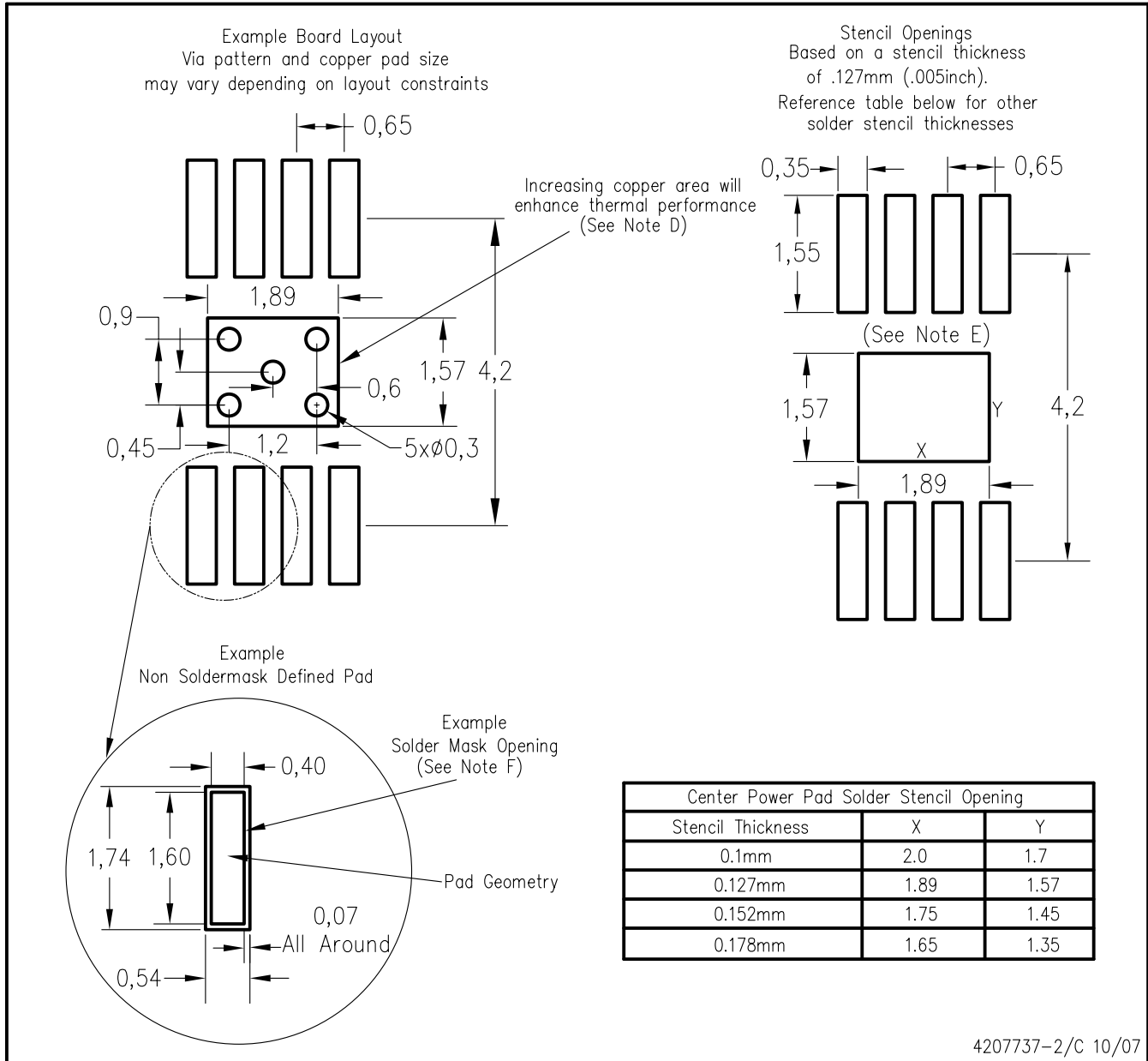

- NOTES:
- A. All linear dimensions are in millimeters.
 - B. This drawing is subject to change without notice.
 - C. Customers should place a note on the circuit board fabrication drawing not to alter the center solder mask defined pad.
 - D. This package is designed to be soldered to a thermal pad on the board. Refer to Technical Brief, PowerPad Thermally Enhanced Package, Texas Instruments Literature No. SLMA002, SLMA004, and also the Product Data Sheets for specific thermal information, via requirements, and recommended board layout. These documents are available at www.ti.com <<http://www.ti.com>>. Publication IPC-7351 is recommended for alternate designs.
 - E. Laser cutting apertures with trapezoidal walls and also rounding corners will offer better paste release. Customers should contact their board assembly site for stencil design recommendations. Example stencil design based on a 50% volumetric metal load solder paste. Refer to IPC-7525 for other stencil recommendations.
 - F. Customers should contact their board fabrication site for solder mask tolerances between and around signal pads.

PW (R-PDSO-G**)

PLASTIC SMALL-OUTLINE PACKAGE

14 PINS SHOWN



4040064/F 01/97

- NOTES: A. All linear dimensions are in millimeters.
 B. This drawing is subject to change without notice.
 C. Body dimensions do not include mold flash or protrusion not to exceed 0,15.
 D. Falls within JEDEC MO-153

MECHANICAL DATA

NS (R-PDSO-G**)

PLASTIC SMALL-OUTLINE PACKAGE

14-PINS SHOWN



- NOTES:
- A. All linear dimensions are in millimeters.
 - B. This drawing is subject to change without notice.
 - C. Body dimensions do not include mold flash or protrusion, not to exceed 0,15.

FK (S-CQCC-N**)

LEADLESS CERAMIC CHIP CARRIER

28 TERMINAL SHOWN

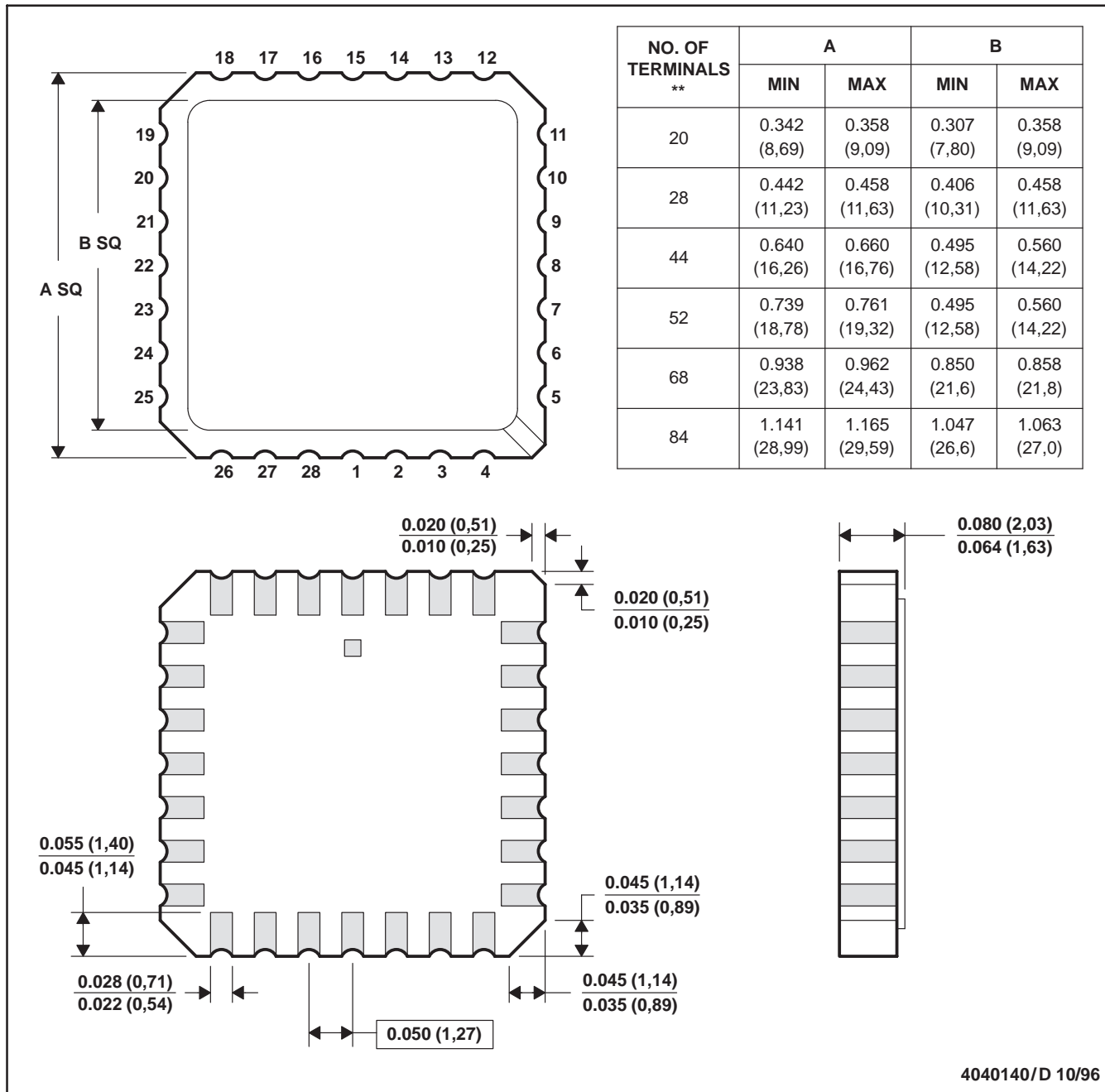

- NOTES:
- A. All linear dimensions are in inches (millimeters).
 - B. This drawing is subject to change without notice.
 - C. This package can be hermetically sealed with a metal lid.
 - D. The terminals are gold plated.
 - E. Falls within JEDEC MS-004

D (R-PDSO-G8)

PLASTIC SMALL-OUTLINE PACKAGE

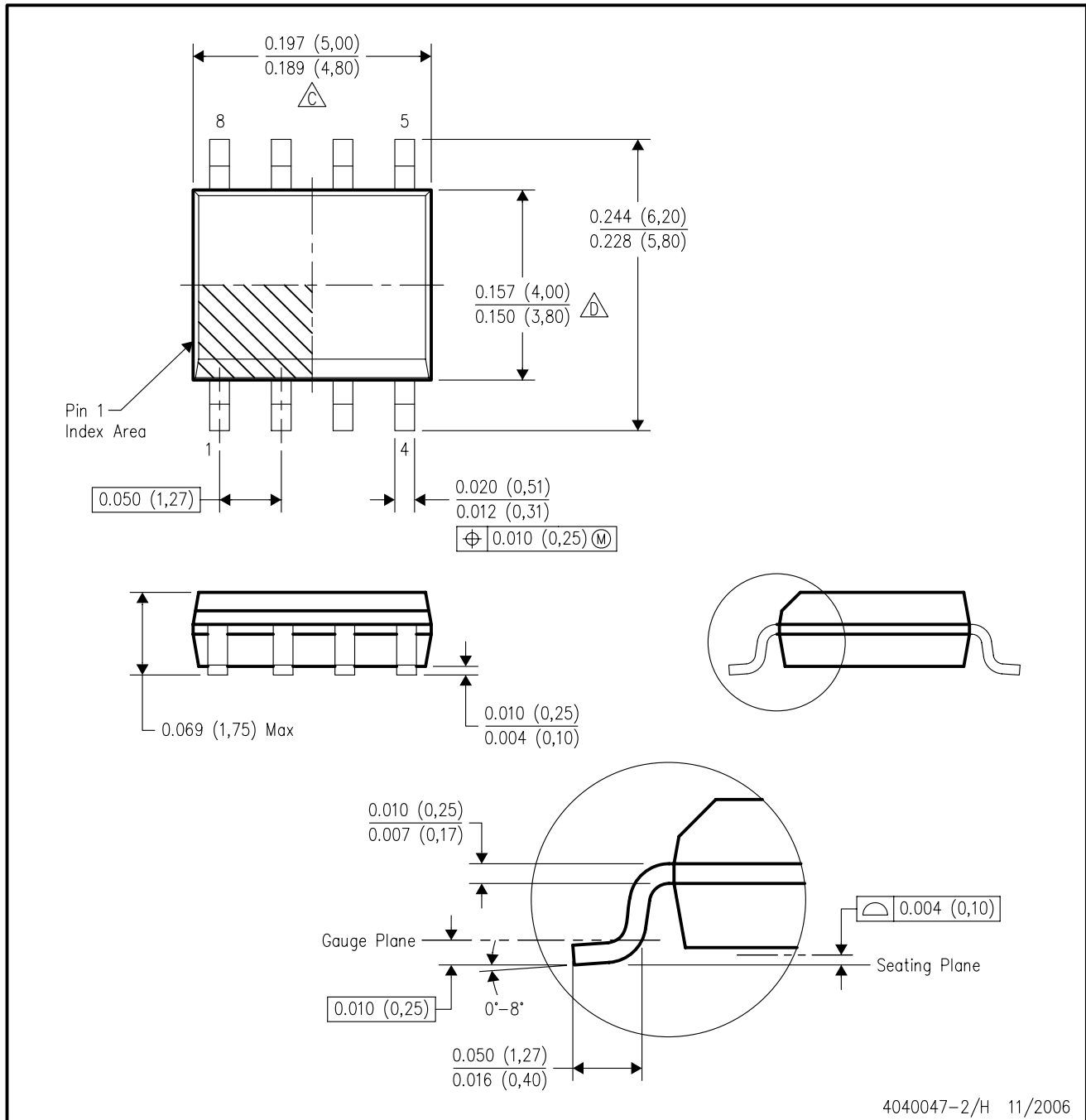

- NOTES:
- A. All linear dimensions are in inches (millimeters).
 - B. This drawing is subject to change without notice.
 - C. Body length does not include mold flash, protrusions, or gate burrs. Mold flash, protrusions, or gate burrs shall not exceed .006 (0,15) per end.
 - D. Body width does not include interlead flash. Interlead flash shall not exceed .017 (0,43) per side.
 - E. Reference JEDEC MS-012 variation AA.

J (R-GDIP-T**)

14 LEADS SHOWN

CERAMIC DUAL IN-LINE PACKAGE



DIM \ PINS **	14	16	18	20
A	0.300 (7,62) BSC	0.300 (7,62) BSC	0.300 (7,62) BSC	0.300 (7,62) BSC
B MAX	0.785 (19,94)	.840 (21,34)	0.960 (24,38)	1.060 (26,92)
B MIN	—	—	—	—
C MAX	0.300 (7,62)	0.300 (7,62)	0.310 (7,87)	0.300 (7,62)
C MIN	0.245 (6,22)	0.245 (6,22)	0.220 (5,59)	0.245 (6,22)



4040083/F 03/03

- NOTES:
- All linear dimensions are in inches (millimeters).
 - This drawing is subject to change without notice.
 - This package is hermetically sealed with a ceramic lid using glass frit.
 - Index point is provided on cap for terminal identification only on press ceramic glass frit seal only.
 - Falls within MIL STD 1835 GDIP1-T14, GDIP1-T16, GDIP1-T18 and GDIP1-T20.

W (R-GDFP-F16)

CERAMIC DUAL FLATPACK

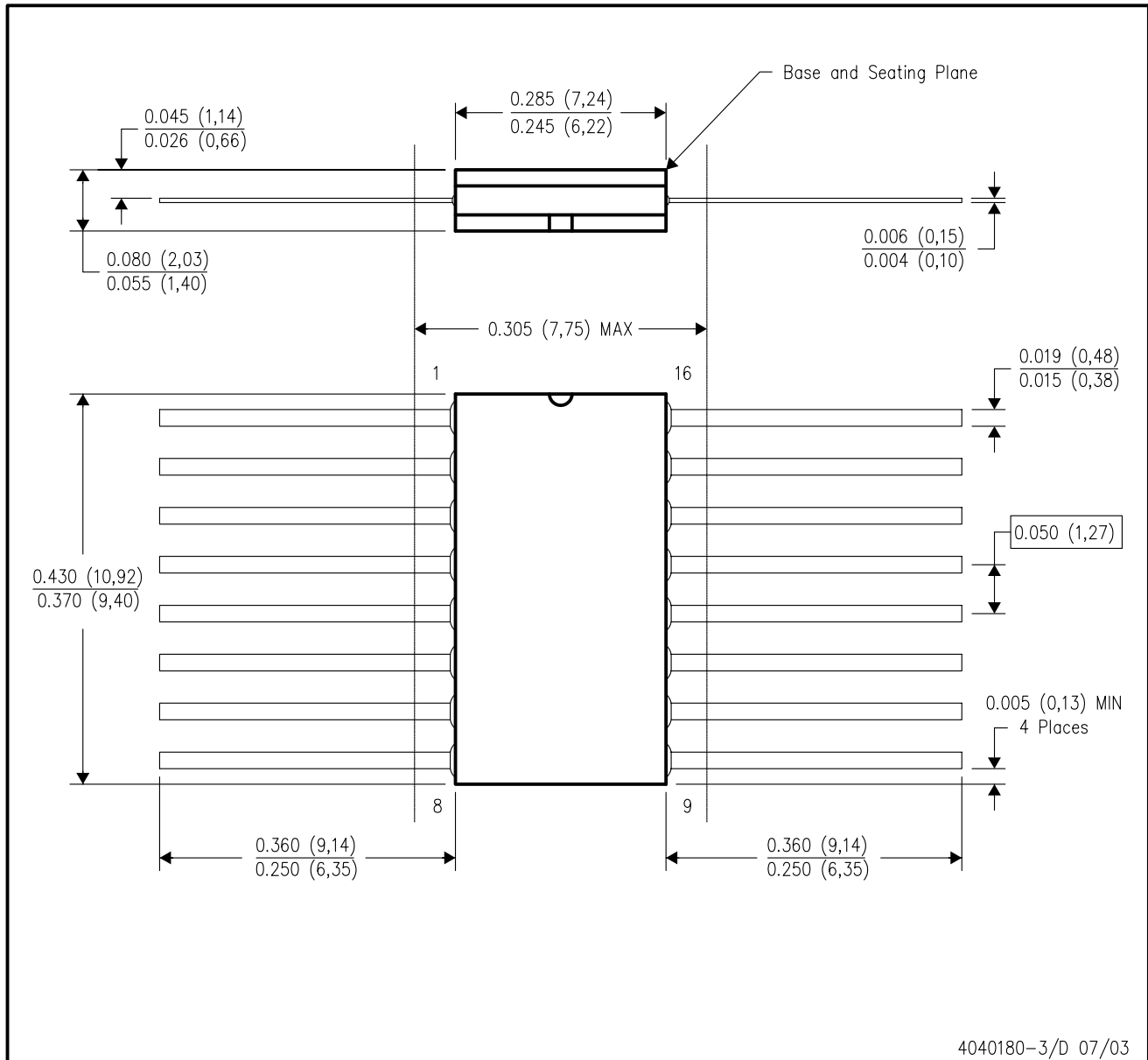

- NOTES:
- A. All linear dimensions are in inches (millimeters).
 - B. This drawing is subject to change without notice.
 - C. This package can be hermetically sealed with a ceramic lid using glass frit.
 - D. Index point is provided on cap for terminal identification only.
 - E. Falls within MIL STD 1835 GDFP1-F16 and JEDEC MO-092AC

DGK (S-PDSO-G8)

PLASTIC SMALL-OUTLINE PACKAGE

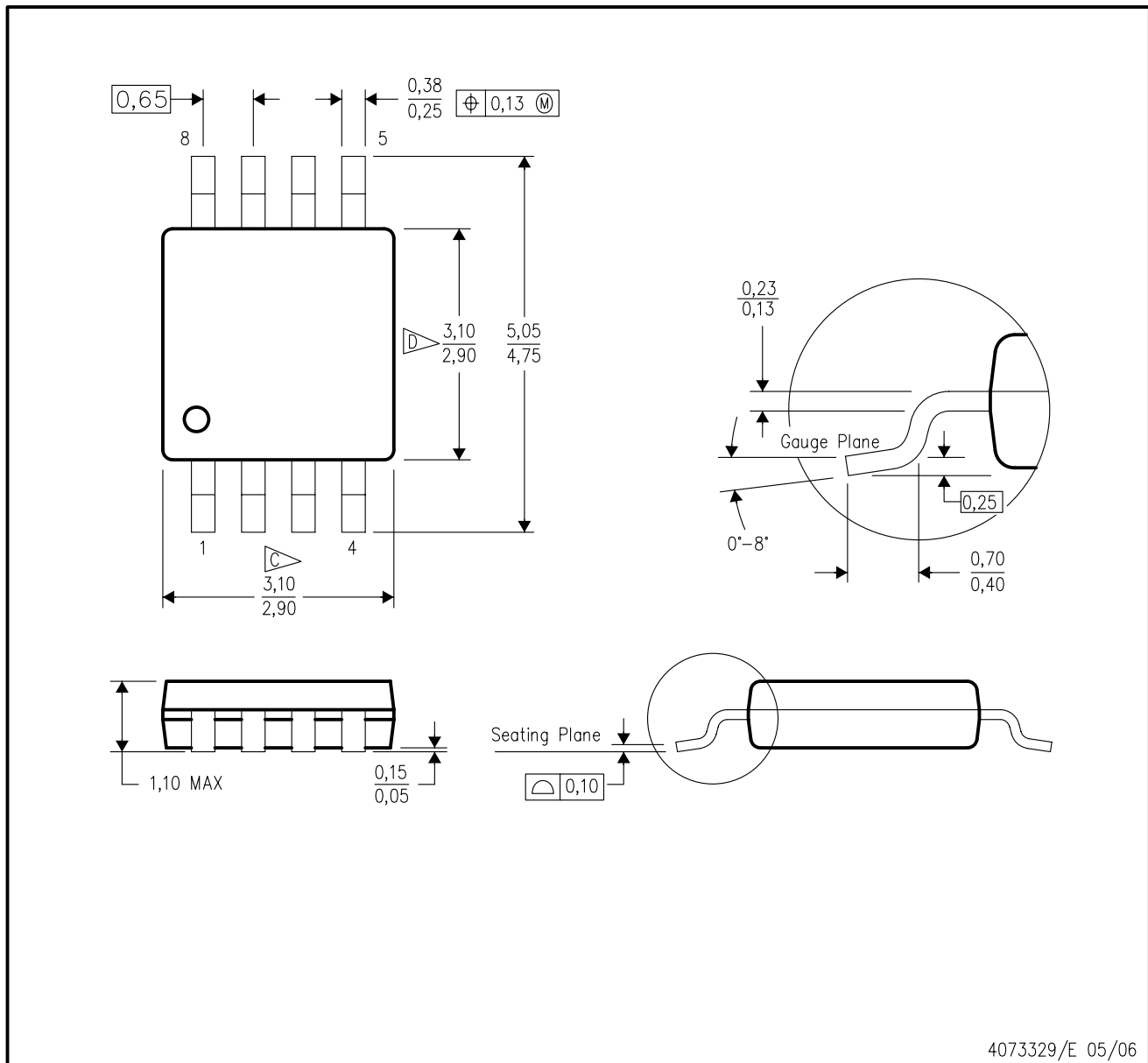

- NOTES:
- A. All linear dimensions are in millimeters.
 - B. This drawing is subject to change without notice.
 - C. Body length does not include mold flash, protrusions, or gate burrs. Mold flash, protrusions, or gate burrs shall not exceed 0.15 per end.
 - D. Body width does not include interlead flash. Interlead flash shall not exceed 0.50 per side.
 - E. Falls within JEDEC MO-187 variation AA, except interlead flash.

D (R-PDSO-G16)

PLASTIC SMALL-OUTLINE PACKAGE

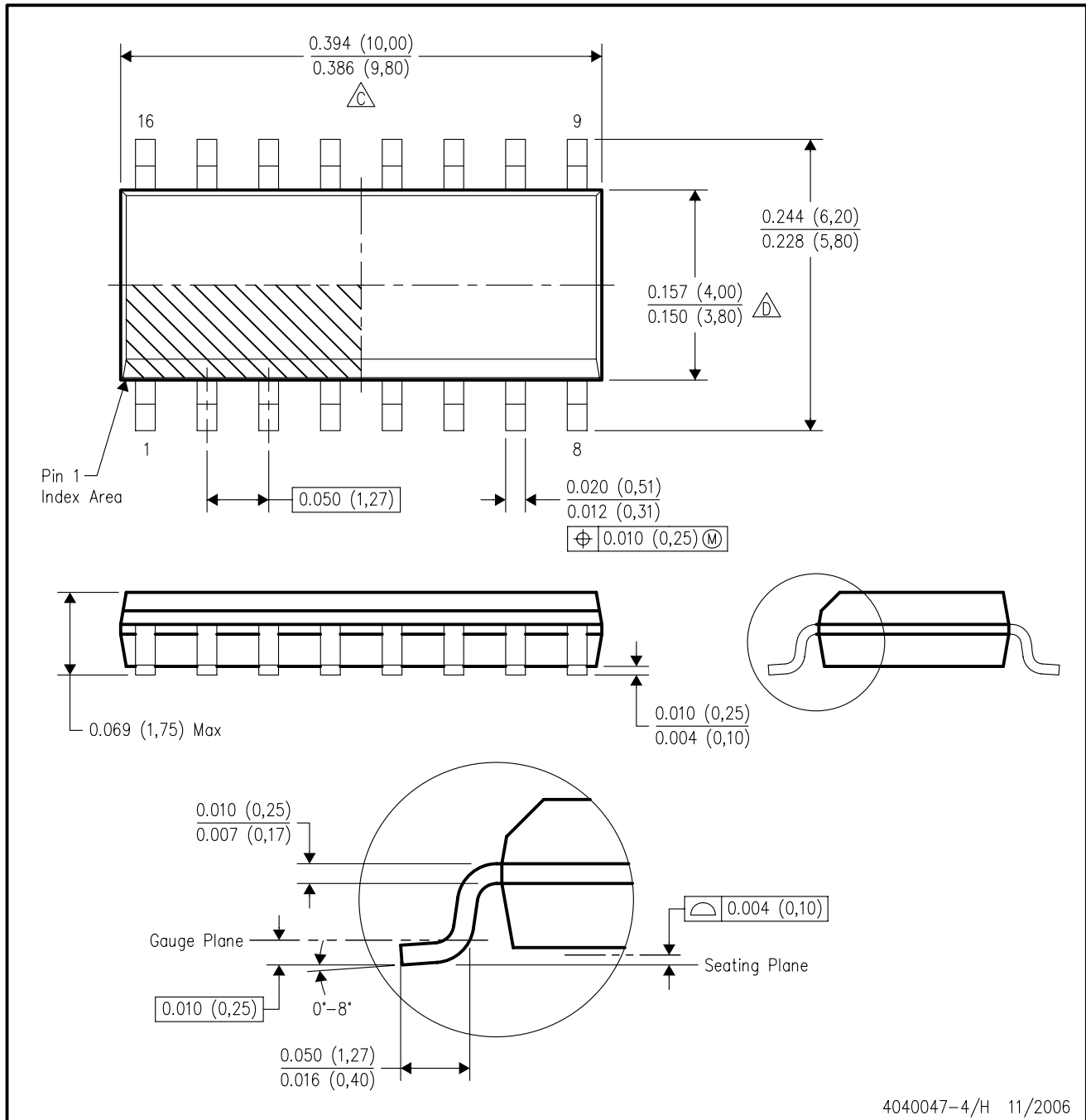

- NOTES:
- A. All linear dimensions are in inches (millimeters).
 - B. This drawing is subject to change without notice.
 - C. Body length does not include mold flash, protrusions, or gate burrs. Mold flash, protrusions, or gate burrs shall not exceed .006 (0,15) per end.
 - D. Body width does not include interlead flash. Interlead flash shall not exceed .017 (0,43) per side.
 - E. Reference JEDEC MS-012 variation AC.

IMPORTANT NOTICE

Texas Instruments Incorporated and its subsidiaries (TI) reserve the right to make corrections, modifications, enhancements, improvements, and other changes to its products and services at any time and to discontinue any product or service without notice. Customers should obtain the latest relevant information before placing orders and should verify that such information is current and complete. All products are sold subject to TI's terms and conditions of sale supplied at the time of order acknowledgment.

TI warrants performance of its hardware products to the specifications applicable at the time of sale in accordance with TI's standard warranty. Testing and other quality control techniques are used to the extent TI deems necessary to support this warranty. Except where mandated by government requirements, testing of all parameters of each product is not necessarily performed.

TI assumes no liability for applications assistance or customer product design. Customers are responsible for their products and applications using TI components. To minimize the risks associated with customer products and applications, customers should provide adequate design and operating safeguards.

TI does not warrant or represent that any license, either express or implied, is granted under any TI patent right, copyright, mask work right, or other TI intellectual property right relating to any combination, machine, or process in which TI products or services are used. Information published by TI regarding third-party products or services does not constitute a license from TI to use such products or services or a warranty or endorsement thereof. Use of such information may require a license from a third party under the patents or other intellectual property of the third party, or a license from TI under the patents or other intellectual property of TI.

Reproduction of TI information in TI data books or data sheets is permissible only if reproduction is without alteration and is accompanied by all associated warranties, conditions, limitations, and notices. Reproduction of this information with alteration is an unfair and deceptive business practice. TI is not responsible or liable for such altered documentation. Information of third parties may be subject to additional restrictions.

Resale of TI products or services with statements different from or beyond the parameters stated by TI for that product or service voids all express and any implied warranties for the associated TI product or service and is an unfair and deceptive business practice. TI is not responsible or liable for any such statements.

TI products are not authorized for use in safety-critical applications (such as life support) where a failure of the TI product would reasonably be expected to cause severe personal injury or death, unless officers of the parties have executed an agreement specifically governing such use. Buyers represent that they have all necessary expertise in the safety and regulatory ramifications of their applications, and acknowledge and agree that they are solely responsible for all legal, regulatory and safety-related requirements concerning their products and any use of TI products in such safety-critical applications, notwithstanding any applications-related information or support that may be provided by TI. Further, Buyers must fully indemnify TI and its representatives against any damages arising out of the use of TI products in such safety-critical applications.

TI products are neither designed nor intended for use in military/aerospace applications or environments unless the TI products are specifically designated by TI as military-grade or "enhanced plastic." Only products designated by TI as military-grade meet military specifications. Buyers acknowledge and agree that any such use of TI products which TI has not designated as military-grade is solely at the Buyer's risk, and that they are solely responsible for compliance with all legal and regulatory requirements in connection with such use.

TI products are neither designed nor intended for use in automotive applications or environments unless the specific TI products are designated by TI as compliant with ISO/TS 16949 requirements. Buyers acknowledge and agree that, if they use any non-designated products in automotive applications, TI will not be responsible for any failure to meet such requirements.

Following are URLs where you can obtain information on other Texas Instruments products and application solutions:

Products

Amplifiers	amplifier.ti.com
Data Converters	dataconverter.ti.com
DSP	dsp.ti.com
Clocks and Timers	www.ti.com/clocks
Interface	interface.ti.com
Logic	logic.ti.com
Power Mgmt	power.ti.com
Microcontrollers	microcontroller.ti.com
RFID	www.ti-rfid.com
RF/IF and ZigBee® Solutions	www.ti.com/lprf

Applications

Audio	www.ti.com/audio
Automotive	www.ti.com/automotive
Broadband	www.ti.com/broadband
Digital Control	www.ti.com/digitalcontrol
Medical	www.ti.com/medical
Military	www.ti.com/military
Optical Networking	www.ti.com/opticalnetwork
Security	www.ti.com/security
Telephony	www.ti.com/telephony
Video & Imaging	www.ti.com/video
Wireless	www.ti.com/wireless

Mailing Address: Texas Instruments, Post Office Box 655303, Dallas, Texas 75265
Copyright © 2008, Texas Instruments Incorporated