

# SN54AHCT74, SN74AHCT74 DUAL POSITIVE-EDGE-TRIGGERED D-TYPE FLIP-FLOPS WITH CLEAR AND PRESET

SCLS263M – DECEMBER 1995 – REVISED SEPTEMBER 2002

- Inputs Are TTL-Voltage Compatible
- Latch-Up Performance Exceeds 250 mA Per JESD 17
- ESD Protection Exceeds JESD 22
  - 2000-V Human-Body Model (A114-A)
  - 200-V Machine Model (A115-A)
  - 1000-V Charged-Device Model (C101)

SN54AHCT74 . . . J OR W PACKAGE  
SN74AHCT74 . . . D, DB, DGV, N, NS,  
OR PW PACKAGE  
(TOP VIEW)

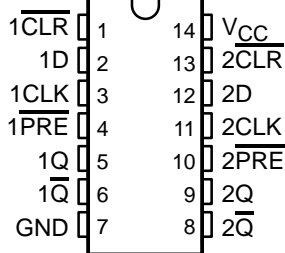

SN74AHCT74 . . . RGY PACKAGE  
(TOP VIEW)

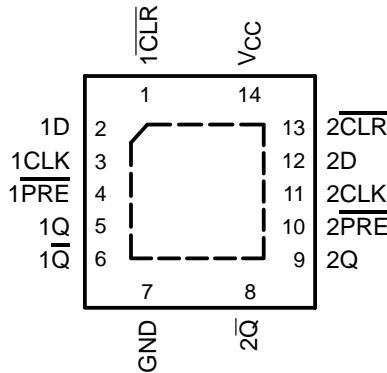

SN54AHCT74 . . . FK PACKAGE  
(TOP VIEW)

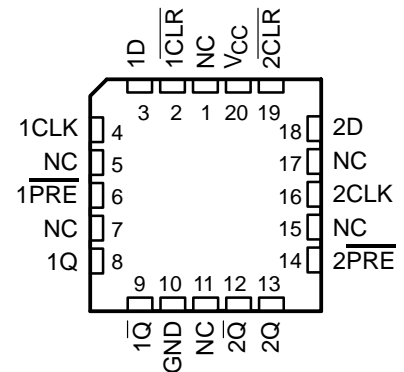

NC – No internal connection

## description/ordering information

The 'AHCT74 dual positive-edge-triggered devices are D-type flip-flops.

A low level at the preset ( $\overline{\text{PRE}}$ ) or clear ( $\overline{\text{CLR}}$ ) inputs sets or resets the outputs, regardless of the levels of the other inputs. When  $\overline{\text{PRE}}$  and  $\overline{\text{CLR}}$  are inactive (high), data at the data (D) input meeting the setup time requirements is transferred to the outputs on the positive-going edge of the clock pulse. Clock triggering occurs at a voltage level and is not directly related to the rise time of the clock pulse. Following the hold-time interval, data at the D input can be changed without affecting the levels at the outputs.

## ORDERING INFORMATION

T <sub>A</sub>	PACKAGE†		ORDERABLE PART NUMBER	TOP-SIDE MARKING
–40°C to 85°C	QFN – RGY	Tape and reel	SN74AHCT74RGYR	HB74
	PDIP – N	Tube	SN74AHCT74N	SN74AHCT74N
	SOIC – D	Tube	SN74AHCT74D	AHCT74
		Tape and reel	SN74AHCT74DR	
	SOP – NS	Tape and reel	SN74AHCT74NSR	AHCT74
	SSOP – DB	Tape and reel	SN74AHCT74DBR	HB74
	TSSOP – PW	Tape and reel	SN74AHCT74PWR	HB74
TVSOP – DGV	Tape and reel	SN74AHCT74DGV	HB74	
–55°C to 125°C	CDIP – J	Tube	SNJ54AHCT74J	SNJ54AHCT74J
	CFP – W	Tube	SNJ54AHCT74W	SNJ54AHCT74W
	LCCC – FK	Tube	SNJ54AHCT74FK	SNJ54AHCT74FK

† Package drawings, standard packing quantities, thermal data, symbolization, and PCB design guidelines are available at [www.ti.com/sc/package](http://www.ti.com/sc/package).



Please be aware that an important notice concerning availability, standard warranty, and use in critical applications of Texas Instruments semiconductor products and disclaimers thereto appears at the end of this data sheet.

PRODUCTION DATA information is current as of publication date. Products conform to specifications per the terms of Texas Instruments standard warranty. Production processing does not necessarily include testing of all parameters.

 **TEXAS  
INSTRUMENTS**

POST OFFICE BOX 655303 • DALLAS, TEXAS 75265

Copyright © 2002, Texas Instruments Incorporated  
On products compliant to MIL-PRF-38535, all parameters are tested unless otherwise noted. On all other products, production processing does not necessarily include testing of all parameters.

# SN54AHCT74, SN74AHCT74 DUAL POSITIVE-EDGE-TRIGGERED D-TYPE FLIP-FLOPS WITH CLEAR AND PRESET

SCLS263M – DECEMBER 1995 – REVISED SEPTEMBER 2002

FUNCTION TABLE  
(each flip-flop)

INPUTS				OUTPUTS	
$\overline{\text{PRE}}$	$\overline{\text{CLR}}$	CLK	D	Q	$\overline{\text{Q}}$
L	H	X	X	H	L
H	L	X	X	L	H
L	L	X	X	H <sup>†</sup>	H <sup>†</sup>
H	H	↑	H	H	L
H	H	↑	L	L	H
H	H	L	X	Q <sub>0</sub>	$\overline{\text{Q}}_0$

<sup>†</sup> This configuration is unstable; that is, it does not persist when  $\overline{\text{PRE}}$  or  $\overline{\text{CLR}}$  returns to its inactive (high) level.

## logic diagram, each flip-flop (positive logic)

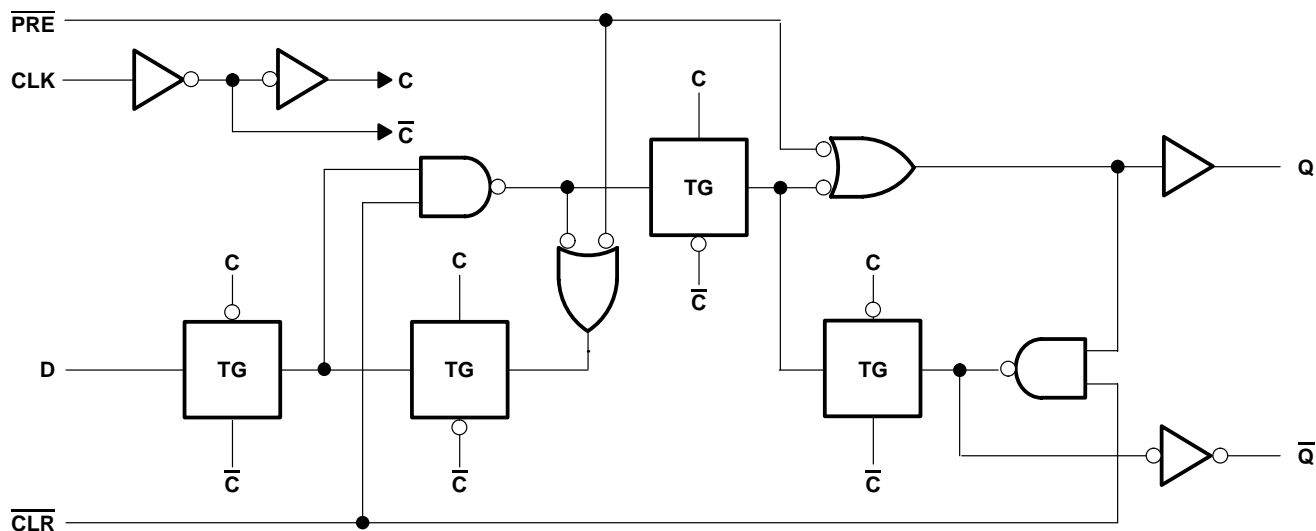

# SN54AHCT74, SN74AHCT74 DUAL POSITIVE-EDGE-TRIGGERED D-TYPE FLIP-FLOPS WITH CLEAR AND PRESET

SCLS263M – DECEMBER 1995 – REVISED SEPTEMBER 2002

## absolute maximum ratings over operating free-air temperature range (unless otherwise noted)†

Supply voltage range, $V_{CC}$ .....	-0.5 V to 7 V
Input voltage range, $V_I$ (see Note 1) .....	-0.5 V to 7 V
Output voltage range, $V_O$ (see Note 1) .....	-0.5 V to $V_{CC} + 0.5$ V
Input clamp current, $I_{IK}$ ( $V_I < 0$ ) .....	-20 mA
Output clamp current, $I_{OK}$ ( $V_O < 0$ or $V_O > V_{CC}$ ) .....	$\pm 20$ mA
Continuous output current, $I_O$ ( $V_O = 0$ to $V_{CC}$ ) .....	$\pm 25$ mA
Continuous current through $V_{CC}$ or GND .....	$\pm 50$ mA
Package thermal impedance, $\theta_{JA}$ (see Note 2): D package .....	86°C/W
(see Note 2): DB package .....	96°C/W
(see Note 2): DGV package .....	127°C/W
(see Note 2): N package .....	80°C/W
(see Note 2): NS package .....	76°C/W
(see Note 2): PW package .....	113°C/W
(see Note 3): RGY package .....	47°C/W
Storage temperature range, $T_{stg}$ .....	-65°C to 150°C

† Stresses beyond those listed under “absolute maximum ratings” may cause permanent damage to the device. These are stress ratings only, and functional operation of the device at these or any other conditions beyond those indicated under “recommended operating conditions” is not implied. Exposure to absolute-maximum-rated conditions for extended periods may affect device reliability.

- NOTES: 1. The input and output voltage ratings may be exceeded if the input and output current ratings are observed.  
 2. The package thermal impedance is calculated in accordance with JESD 51-7.  
 3. The package thermal impedance is calculated in accordance with JESD 51-5.

## recommended operating conditions (see Note 4)

	SN54AHCT74		SN74AHCT74		UNIT
	MIN	MAX	MIN	MAX	
$V_{CC}$ Supply voltage	4.5	5.5	4.5	5.5	V
$V_{IH}$ High-level input voltage	2		2		V
$V_{IL}$ Low-level input voltage		0.8		0.8	V
$V_I$ Input voltage	0	5.5	0	5.5	V
$V_O$ Output voltage	0	$V_{CC}$	0	$V_{CC}$	V
$I_{OH}$ High-level output current		-8		-8	mA
$I_{OL}$ Low-level output current		8		8	mA
$\Delta t/\Delta v$ Input transition rise or fall rate		20		20	ns/V
$T_A$ Operating free-air temperature	-55	125	-40	85	°C

NOTE 4: All unused inputs of the device must be held at  $V_{CC}$  or GND to ensure proper device operation. Refer to the TI application report, *Implications of Slow or Floating CMOS Inputs*, literature number SCBA004.



# SN54AHCT74, SN74AHCT74 DUAL POSITIVE-EDGE-TRIGGERED D-TYPE FLIP-FLOPS WITH CLEAR AND PRESET

SCLS263M – DECEMBER 1995 – REVISED SEPTEMBER 2002

electrical characteristics over recommended operating free-air temperature range (unless otherwise noted)

PARAMETER	TEST CONDITIONS	V <sub>CC</sub>	T <sub>A</sub> = 25°C			SN54AHCT74		SN74AHCT74		UNIT
			MIN	TYP	MAX	MIN	MAX	MIN	MAX	
V <sub>OH</sub>	I <sub>OH</sub> = -50 μA	4.5 V	4.4	4.5		4.4		4.4	V	
	I <sub>OH</sub> = -8 mA		3.94			3.8		3.8		
V <sub>OL</sub>	I <sub>OL</sub> = 50 μA	4.5 V			0.1			0.1	V	
	I <sub>OL</sub> = 8 mA				0.36		0.44	0.44		
I <sub>I</sub>	V <sub>I</sub> = 5.5 V or GND	0 V to 5.5 V			±0.1		±1*	±1	μA	
I <sub>CC</sub>	V <sub>I</sub> = V <sub>CC</sub> or GND, I <sub>O</sub> = 0	5.5 V			2		20	20	μA	
ΔI <sub>CC</sub> †	One input at 3.4 V, Other inputs at V <sub>CC</sub> or GND	5.5 V			1.35		1.5	1.5	mA	
C <sub>i</sub>	V <sub>I</sub> = V <sub>CC</sub> or GND	5 V			2	10		10	pF	

\* On products compliant to MIL-PRF-38535, this parameter is not production tested at V<sub>CC</sub> = 0 V.

† This is the increase in supply current for each input at one of the specified TTL voltage levels rather than 0 V or V<sub>CC</sub>.

timing requirements over recommended operating free-air temperature range, V<sub>CC</sub> = 5 V ± 0.5 V (unless otherwise noted) (see Figure 1)

PARAMETER		T <sub>A</sub> = 25°C		SN54AHCT74		SN74AHCT74		UNIT
		MIN	MAX	MIN	MAX	MIN	MAX	
t <sub>w</sub>	Pulse duration	PRE or CLR low	5		5		5	ns
		CLK	5		5		5	
t <sub>su</sub>	Setup time before CLK↑	Data	5		5		5	ns
		PRE or CLR inactive	3.5		3.5		3.5	
t <sub>h</sub>	Hold time, data after CLK↑		0		0		0	ns

switching characteristics over recommended operating free-air temperature range, V<sub>CC</sub> = 5 V ± 0.5 V (unless otherwise noted) (see Figure 1)

PARAMETER	FROM (INPUT)	TO (OUTPUT)	LOAD CAPACITANCE	T <sub>A</sub> = 25°C			SN54AHCT74		SN74AHCT74		UNIT
				MIN	TYP	MAX	MIN	MAX	MIN	MAX	
f <sub>max</sub>			C <sub>L</sub> = 15 pF	100**	160**		80**		80	MHz	
			C <sub>L</sub> = 50 pF	80	140		65		65		
t <sub>PLH</sub>	PRE or CLR	Q or Q̄	C <sub>L</sub> = 15 pF	7.6**	10.4**		1**	12**	1	12	ns
t <sub>PHL</sub>				7.6**	10.4**		1**	12**	1	12	
t <sub>PLH</sub>	CLK	Q or Q̄	C <sub>L</sub> = 15 pF	5.8**	7.8**		1**	9**	1	9	ns
t <sub>PHL</sub>				5.8**	7.8**		1**	9**	1	9	
t <sub>PLH</sub>	PRE or CLR	Q or Q̄	C <sub>L</sub> = 50 pF	8.1	11.4		1	13	1	13	ns
t <sub>PHL</sub>				8.1	11.4		1	13	1	13	
t <sub>PLH</sub>	CLK	Q or Q̄	C <sub>L</sub> = 50 pF	6.3	8.8		1	10	1	10	ns
t <sub>PHL</sub>				6.3	8.8		1	10	1	10	

\*\* On products compliant to MIL-PRF-38535, this parameter is not production tested.



# SN54AHCT74, SN74AHCT74 DUAL POSITIVE-EDGE-TRIGGERED D-TYPE FLIP-FLOPS WITH CLEAR AND PRESET

SCLS263M – DECEMBER 1995 – REVISED SEPTEMBER 2002

**noise characteristics,  $V_{CC} = 5\text{ V}$ ,  $C_L = 50\text{ pF}$ ,  $T_A = 25^\circ\text{C}$  (see Note 5)**

PARAMETER	SN74AHCT74		UNIT
	MIN	MAX	
$V_{OL(P)}$ Quiet output, maximum dynamic $V_{OL}$	0.8		V
$V_{OL(V)}$ Quiet output, minimum dynamic $V_{OL}$	-0.8		V
$V_{OH(V)}$ Quiet output, minimum dynamic $V_{OH}$	4		V
$V_{IH(D)}$ High-level dynamic input voltage	2		V
$V_{IL(D)}$ Low-level dynamic input voltage	0.8		V

NOTE 5: Characteristics are for surface-mount packages only.

**operating characteristics,  $V_{CC} = 5\text{ V}$ ,  $T_A = 25^\circ\text{C}$**

PARAMETER	TEST CONDITIONS	TYP	UNIT
$C_{pd}$ Power dissipation capacitance	No load, $f = 1\text{ MHz}$	32	pF

# SN54AHCT74, SN74AHCT74 DUAL POSITIVE-EDGE-TRIGGERED D-TYPE FLIP-FLOPS WITH CLEAR AND PRESET

SCLS263M – DECEMBER 1995 – REVISED SEPTEMBER 2002

## PARAMETER MEASUREMENT INFORMATION

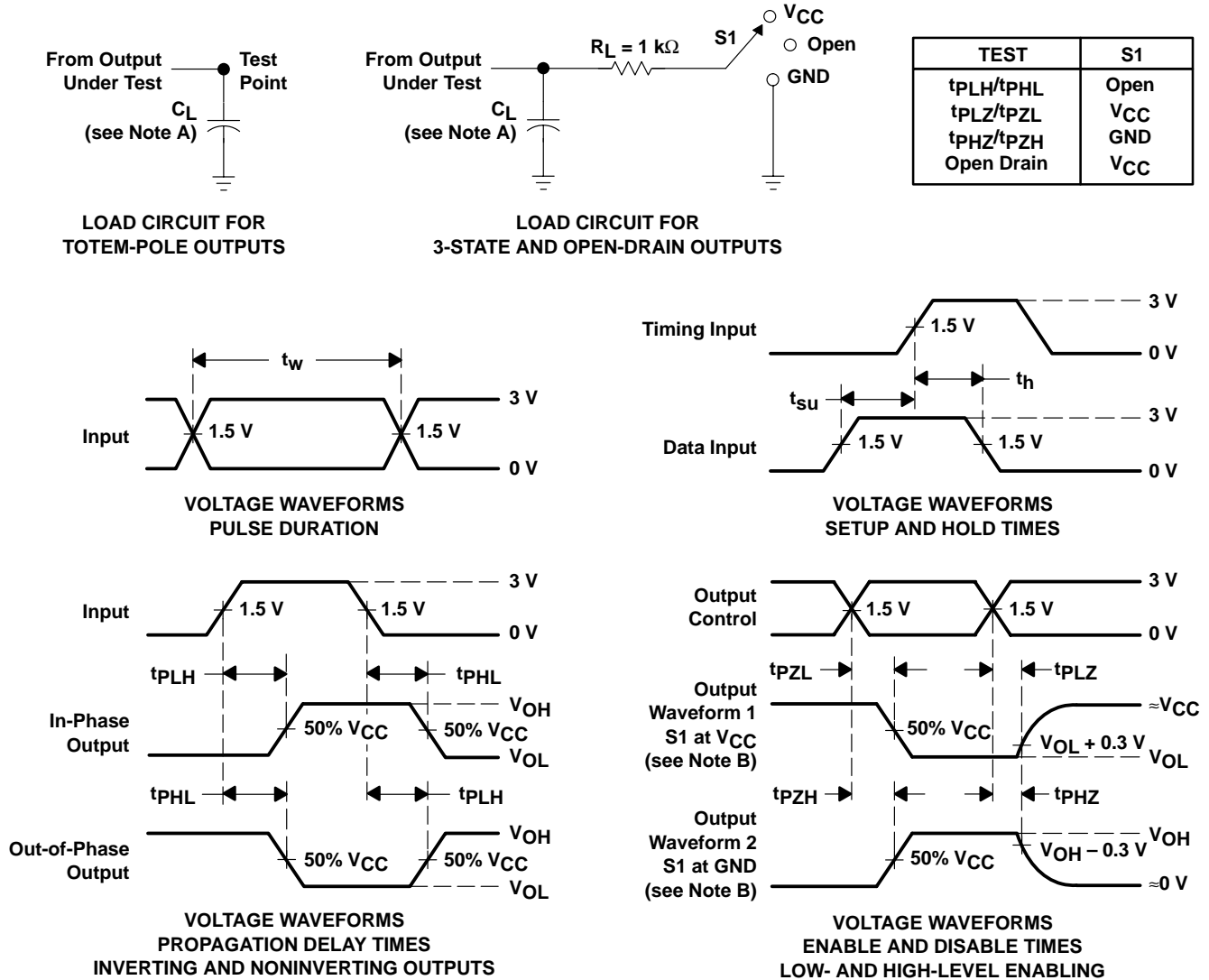

- NOTES:
- A.  $C_L$  includes probe and jig capacitance.
  - B. Waveform 1 is for an output with internal conditions such that the output is low except when disabled by the output control. Waveform 2 is for an output with internal conditions such that the output is high except when disabled by the output control.
  - C. All input pulses are supplied by generators having the following characteristics:  $PRR \leq 1\text{ MHz}$ ,  $Z_O = 50\ \Omega$ ,  $t_r \leq 3\text{ ns}$ ,  $t_f \leq 3\text{ ns}$ .
  - D. The outputs are measured one at a time with one input transition per measurement.
  - E. All parameters and waveforms are not applicable to all devices.

Figure 1. Load Circuit and Voltage Waveforms

## IMPORTANT NOTICE

Texas Instruments Incorporated and its subsidiaries (TI) reserve the right to make corrections, modifications, enhancements, improvements, and other changes to its products and services at any time and to discontinue any product or service without notice. Customers should obtain the latest relevant information before placing orders and should verify that such information is current and complete. All products are sold subject to TI's terms and conditions of sale supplied at the time of order acknowledgment.

TI warrants performance of its hardware products to the specifications applicable at the time of sale in accordance with TI's standard warranty. Testing and other quality control techniques are used to the extent TI deems necessary to support this warranty. Except where mandated by government requirements, testing of all parameters of each product is not necessarily performed.

TI assumes no liability for applications assistance or customer product design. Customers are responsible for their products and applications using TI components. To minimize the risks associated with customer products and applications, customers should provide adequate design and operating safeguards.

TI does not warrant or represent that any license, either express or implied, is granted under any TI patent right, copyright, mask work right, or other TI intellectual property right relating to any combination, machine, or process in which TI products or services are used. Information published by TI regarding third-party products or services does not constitute a license from TI to use such products or services or a warranty or endorsement thereof. Use of such information may require a license from a third party under the patents or other intellectual property of the third party, or a license from TI under the patents or other intellectual property of TI.

Reproduction of information in TI data books or data sheets is permissible only if reproduction is without alteration and is accompanied by all associated warranties, conditions, limitations, and notices. Reproduction of this information with alteration is an unfair and deceptive business practice. TI is not responsible or liable for such altered documentation.

Resale of TI products or services with statements different from or beyond the parameters stated by TI for that product or service voids all express and any implied warranties for the associated TI product or service and is an unfair and deceptive business practice. TI is not responsible or liable for any such statements.

### Mailing Address:

Texas Instruments  
Post Office Box 655303  
Dallas, Texas 75265