

SN54AHCT14, SN74AHCT14 HEX SCHMITT-TRIGGER INVERTERS

SCLS2460 – OCTOBER 1995 – REVISED SEPTEMBER 2002

- Inputs Are TTL-Voltage Compatible
- Latch-Up Performance Exceeds 250 mA Per JESD 17
- ESD Protection Exceeds JESD 22
 - 2000-V Human-Body Model (A114-A)
 - 200-V Machine Model (A115-A)
 - 1000-V Charged-Device Model (C101)

SN54AHCT14 . . . J OR W PACKAGE
SN74AHCT14 . . . D, DB, DGV, N, NS,
OR PW PACKAGE
(TOP VIEW)

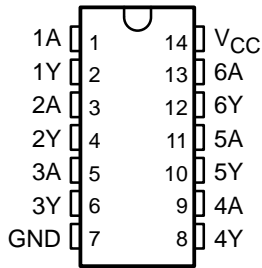

SN74AHCT14 . . . RGY PACKAGE
(TOP VIEW)

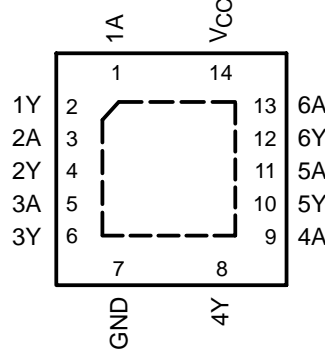

SN54AHCT14 . . . FK PACKAGE
(TOP VIEW)

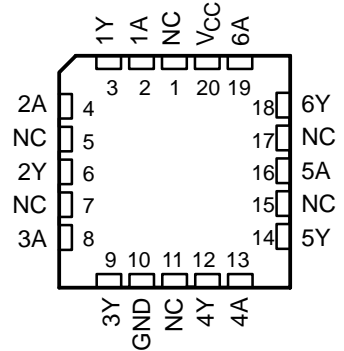

NC – No internal connection

description/ordering information

The 'AHCT14 devices contain six independent inverters. These devices perform the Boolean function $Y = \bar{A}$. Each circuit functions as an independent inverter, but because of the Schmitt action, the inverters have different input threshold levels for positive-going (V_{T+}) and for negative-going (V_{T-}) signals.

ORDERING INFORMATION

| TA | PACKAGE† | | ORDERABLE PART NUMBER | TOP-SIDE MARKING |
|----------------|---------------|---------------|-----------------------|------------------|
| –40°C to 85°C | QFN – RGY | Tape and reel | SN74AHCT14RGYR | HB14 |
| | PDIP – N | Tube | SN74AHCT14N | SN74AHCT14N |
| | SOIC – D | Tube | SN74AHCT14D | AHCT14 |
| | | Tape and reel | SN74AHCT14DR | |
| | SOP – NS | Tape and reel | SN74AHCT14NSR | AHCT14 |
| | SSOP – DB | Tape and reel | SN74AHCT14DBR | HB14 |
| | TSSOP – PW | Tape and reel | SN74AHCT14PWR | HB14 |
| TVSOP – DGV | Tape and reel | SN74AHCT14DGV | HB14 | |
| –55°C to 125°C | CDIP – J | Tube | SNJ54AHCT14J | SNJ54AHCT14J |
| | CFP – W | Tube | SNJ54AHCT14W | SNJ54AHCT14W |
| | LCCC – FK | Tube | SNJ54AHCT14FK | SNJ54AHCT14FK |

† Package drawings, standard packing quantities, thermal data, symbolization, and PCB design guidelines are available at www.ti.com/sc/package.



Please be aware that an important notice concerning availability, standard warranty, and use in critical applications of Texas Instruments semiconductor products and disclaimers thereto appears at the end of this data sheet.

PRODUCTION DATA information is current as of publication date. Products conform to specifications per the terms of Texas Instruments standard warranty. Production processing does not necessarily include testing of all parameters.

**TEXAS
INSTRUMENTS**

POST OFFICE BOX 655303 • DALLAS, TEXAS 75265

Copyright © 2002, Texas Instruments Incorporated
On products compliant to MIL-PRF-38535, all parameters are tested unless otherwise noted. On all other products, production processing does not necessarily include testing of all parameters.

SN54AHCT14, SN74AHCT14 HEX SCHMITT-TRIGGER INVERTERS

SCLS2460 – OCTOBER 1995 – REVISED SEPTEMBER 2002

FUNCTION TABLE
(each inverter)

| INPUT A | OUTPUT Y |
|------------|-------------|
| H | L |
| L | H |

logic diagram, each inverter (positive logic)

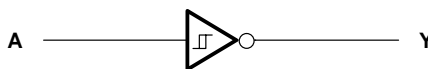

absolute maximum ratings over operating free-air temperature range (unless otherwise noted)†

| | |
|--|----------------------------|
| Supply voltage range, V_{CC} | -0.5 V to 7 V |
| Input voltage range, V_I (see Note 1) | -0.5 V to 7 V |
| Output voltage range, V_O (see Note 1) | -0.5 V to $V_{CC} + 0.5$ V |
| Input clamp current, I_{IK} ($V_I < 0$) | -20 mA |
| Output clamp current, I_{OK} ($V_O < 0$ or $V_O > V_{CC}$) | ±20 mA |
| Continuous output current, I_O ($V_O = 0$ to V_{CC}) | ±25 mA |
| Continuous current through V_{CC} or GND | ±50 mA |
| Package thermal impedance, θ_{JA} (see Note 2): D package | 86°C/W |
| (see Note 2): DB package | 96°C/W |
| (see Note 2): DGV package | 127°C/W |
| (see Note 2): N package | 80°C/W |
| (see Note 2): NS package | 76°C/W |
| (see Note 2): PW package | 113°C/W |
| (see Note 3): RGY package | 47°C/W |
| Storage temperature range, T_{stg} | -65°C to 150°C |

† Stresses beyond those listed under “absolute maximum ratings” may cause permanent damage to the device. These are stress ratings only, and functional operation of the device at these or any other conditions beyond those indicated under “recommended operating conditions” is not implied. Exposure to absolute-maximum-rated conditions for extended periods may affect device reliability.

- NOTES:
1. The input and output voltage ratings may be exceeded if the input and output current ratings are observed.
 2. The package thermal impedance is calculated in accordance with JESD 51-7.
 3. The package thermal impedance is calculated in accordance with JESD 51-5.

recommended operating conditions (see Note 4)

| | SN54AHCT14 | | SN74AHCT14 | | UNIT |
|--------------------------------------|------------|----------|------------|----------|------|
| | MIN | MAX | MIN | MAX | |
| V_{CC} Supply voltage | 4.5 | 5.5 | 4.5 | 5.5 | V |
| V_I Input voltage | 0 | 5.5 | 0 | 5.5 | V |
| V_O Output voltage | 0 | V_{CC} | 0 | V_{CC} | V |
| I_{OH} High-level output current | | -8 | | -8 | mA |
| I_{OL} Low-level output current | | 8 | | 8 | mA |
| T_A Operating free-air temperature | -55 | 125 | -40 | 85 | °C |

NOTE 4: All unused inputs of the device must be held at V_{CC} or GND to ensure proper device operation. Refer to the TI application report, *Implications of Slow or Floating CMOS Inputs*, literature number SCBA004.



SN54AHCT14, SN74AHCT14 HEX SCHMITT-TRIGGER INVERTERS

SCLS2460 – OCTOBER 1995 – REVISED SEPTEMBER 2002

electrical characteristics over recommended operating free-air temperature range (unless otherwise noted)

| PARAMETER | TEST CONDITIONS | V _{CC} | T _A = 25°C | | | SN54AHCT14 | | SN74AHCT14 | | UNIT |
|--|---|-----------------|-----------------------|-----|------|------------|------|------------|------|------|
| | | | MIN | TYP | MAX | MIN | MAX | MIN | MAX | |
| V _{T+} Positive-going input threshold voltage | | 4.5 V | 0.9 | | 1.9 | 0.9 | 1.9 | 0.9 | 1.9 | V |
| | | 5.5 V | 1 | | 2.1 | 1 | 2.1 | 1 | 2.1 | |
| V _{T-} Negative-going input threshold voltage | | 4.5 V | 0.5 | | 1.5 | 0.5 | 1.5 | 0.5 | 1.5 | V |
| | | 5.5 V | 0.6 | | 1.7 | 0.6 | 1.7 | 0.6 | 1.7 | |
| ΔV _T Hysteresis (V _{T+} - V _{T-}) | | 4.5 V | 0.4 | | 1.4 | 0.4 | 1.4 | 0.4 | 1.4 | V |
| | | 5.5 V | 0.4 | | 1.5 | 0.4 | 1.5 | 0.4 | 1.5 | |
| V _{OH} | I _{OH} = -50 μA | 4.5 V | 4.4 | 4.5 | | 4.4 | | 4.4 | | V |
| | I _{OH} = -8 mA | 4.5 V | 3.94 | | | 3.8 | | 3.8 | | |
| V _{OL} | I _{OL} = 50 μA | 4.5 V | | | 0.1 | | 0.1 | | 0.1 | V |
| | I _{OL} = 8 mA | 4.5 V | | | 0.36 | | 0.44 | | 0.44 | |
| I _I | V _I = 5.5 V or GND | 0 V to 5.5 V | | | | ±0.1 | | ±1* | | μA |
| I _{CC} | V _I = V _{CC} or GND, I _O = 0 | 5.5 V | | | 2 | | 20 | | 20 | μA |
| ΔI _{CC} † | One input at 3.4 V, Other inputs at V _{CC} or GND | 5.5 V | | | 1.35 | | 1.5 | | 1.5 | mA |
| C _i | V _I = V _{CC} or GND | 5 V | | 2 | 10 | | | | 10 | pF |

* On products compliant to MIL-PRF-38535, this parameter is not production tested at V_{CC} = 0 V.

† This is the increase in supply current for each input at one of the specified TTL voltage levels rather than 0 V or V_{CC}.

switching characteristics over recommended operating free-air temperature range
V_{CC} = 5 V ± 0.5 V (unless otherwise noted) (see Figure 1)

| PARAMETER | FROM (INPUT) | TO (OUTPUT) | LOAD CAPACITANCE | T _A = 25°C | | | SN54AHCT14 | | SN74AHCT14 | | UNIT |
|------------------|--------------|-------------|------------------------|-----------------------|-----|-----|------------|-----|------------|-----|------|
| | | | | MIN | TYP | MAX | MIN | MAX | MIN | MAX | |
| t _{PLH} | A | Y | C _L = 15 pF | | 4** | 7** | 1** | 8** | 1 | 8 | ns |
| t _{PHL} | | | | | 4** | 7** | 1** | 8** | 1 | 8 | |
| t _{PLH} | A | Y | C _L = 50 pF | | 5.5 | 8 | 1 | 9 | 1 | 9 | ns |
| t _{PHL} | | | | | 5.5 | 8 | 1 | 9 | 1 | 9 | |

** On products compliant to MIL-PRF-38535, this parameter is not production tested.

noise characteristics, V_{CC} = 5 V, C_L = 50 pF, T_A = 25°C (see Note 5)

| PARAMETER | | SN74AHCT14 | | | UNIT |
|--------------------|---|------------|------|-----|------|
| | | MIN | TYP | MAX | |
| V _{OL(P)} | Quiet output, maximum dynamic V _{OL} | | 0.9 | | V |
| V _{OL(V)} | Quiet output, minimum dynamic V _{OL} | | -0.7 | | V |
| V _{OH(V)} | Quiet output, minimum dynamic V _{OH} | | 4.3 | | V |
| V _{IH(D)} | High-level dynamic input voltage | | 2.1 | | V |
| V _{IL(D)} | Low-level dynamic input voltage | | | 0.5 | V |

NOTE 5: Characteristics are for surface-mount packages only.

operating characteristics, V_{CC} = 5 V, T_A = 25°C

| PARAMETER | TEST CONDITIONS | TYP | UNIT |
|---|--------------------|-----|------|
| C _{pd} Power dissipation capacitance | No load, f = 1 MHz | 12 | pF |



SN54AHCT14, SN74AHCT14 HEX SCHMITT-TRIGGER INVERTERS

SCLS2460 – OCTOBER 1995 – REVISED SEPTEMBER 2002

PARAMETER MEASUREMENT INFORMATION

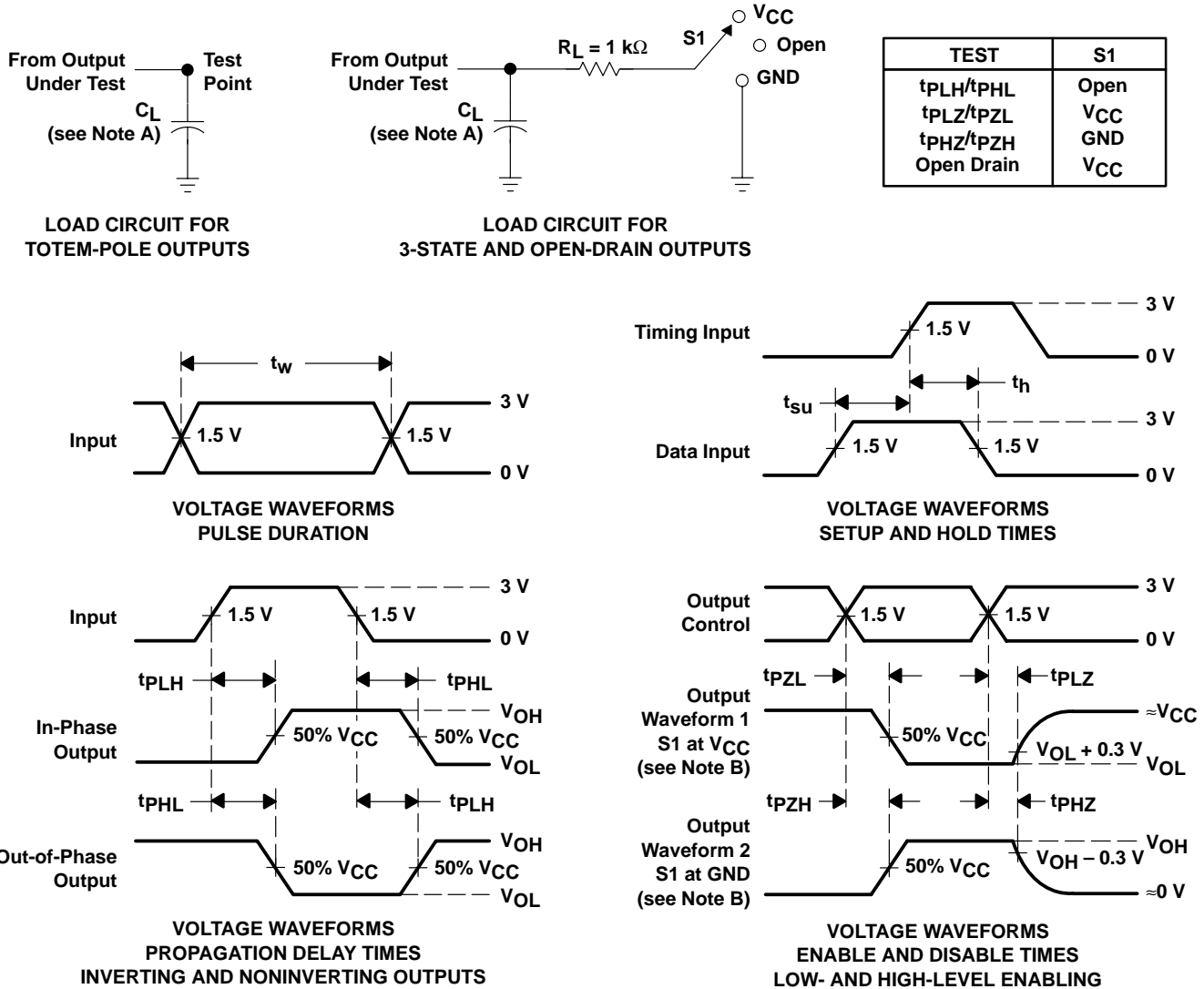

- NOTES:
- A. C_L includes probe and jig capacitance.
 - B. Waveform 1 is for an output with internal conditions such that the output is low except when disabled by the output control. Waveform 2 is for an output with internal conditions such that the output is high except when disabled by the output control.
 - C. All input pulses are supplied by generators having the following characteristics: PRR \leq 1 MHz, $Z_O = 50 \Omega$, $t_r \leq 3$ ns, $t_f \leq 3$ ns.
 - D. The outputs are measured one at a time with one input transition per measurement.
 - E. All parameters and waveforms are not applicable to all devices.

Figure 1. Load Circuit and Voltage Waveforms

IMPORTANT NOTICE

Texas Instruments Incorporated and its subsidiaries (TI) reserve the right to make corrections, modifications, enhancements, improvements, and other changes to its products and services at any time and to discontinue any product or service without notice. Customers should obtain the latest relevant information before placing orders and should verify that such information is current and complete. All products are sold subject to TI's terms and conditions of sale supplied at the time of order acknowledgment.

TI warrants performance of its hardware products to the specifications applicable at the time of sale in accordance with TI's standard warranty. Testing and other quality control techniques are used to the extent TI deems necessary to support this warranty. Except where mandated by government requirements, testing of all parameters of each product is not necessarily performed.

TI assumes no liability for applications assistance or customer product design. Customers are responsible for their products and applications using TI components. To minimize the risks associated with customer products and applications, customers should provide adequate design and operating safeguards.

TI does not warrant or represent that any license, either express or implied, is granted under any TI patent right, copyright, mask work right, or other TI intellectual property right relating to any combination, machine, or process in which TI products or services are used. Information published by TI regarding third-party products or services does not constitute a license from TI to use such products or services or a warranty or endorsement thereof. Use of such information may require a license from a third party under the patents or other intellectual property of the third party, or a license from TI under the patents or other intellectual property of TI.

Reproduction of information in TI data books or data sheets is permissible only if reproduction is without alteration and is accompanied by all associated warranties, conditions, limitations, and notices. Reproduction of this information with alteration is an unfair and deceptive business practice. TI is not responsible or liable for such altered documentation.

Resale of TI products or services with statements different from or beyond the parameters stated by TI for that product or service voids all express and any implied warranties for the associated TI product or service and is an unfair and deceptive business practice. TI is not responsible or liable for any such statements.

Mailing Address:

Texas Instruments
Post Office Box 655303
Dallas, Texas 75265