



MULTI-CLOCK GENERATOR

FEATURES

- 27MHz MASTER CLOCK INPUT
- GENERATED AUDIO SYSTEM CLOCK:
 - SCKO1: 33.8688MHz (Fixed)
 - SCKO2: $256f_S$
 - SCKO3: $384f_S$
 - SCKO4: $768f_S$
- ZERO PPM ERROR OUTPUT CLOCKS
- LOW CLOCK JITTER: 150ps at SCKO3
- MULTIPLE SAMPLING FREQUENCIES:
 - $f_S = 32\text{kHz}, 44.1\text{kHz}, 48\text{kHz}, 64\text{kHz},$
 - $88.2\text{kHz}, 96\text{kHz}$
- +3.3V CMOS LOGIC INTERFACE
- DUAL POWER SUPPLIES: +5V and +3.3V
- SMALL PACKAGE: 20-Lead SSOP

DESCRIPTION

The PLL1700 is a low cost, multi-clock generator Phase Lock Loop (PLL).

The PLL1700 can generate four systems clocks from a 27MHz reference input frequency.

The device gives customers both cost and space savings by eliminating external components and enables customers to achieve the very low jitter performance needed for high-performance audio digital-to-analog converters (DACs) and/or analog-to-digital converters (ADCs).

The PLL1700 is ideal for MPEG-2 applications that use a 27MHz master clock such as DVD players, DVD add-on cards for multimedia PCs, digital HDTV systems, and set-top boxes.

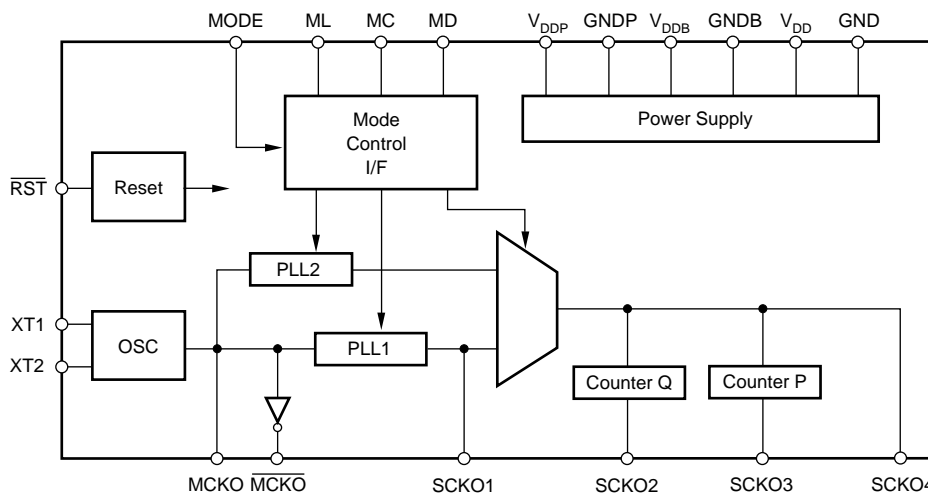

Please be aware that an important notice concerning availability, standard warranty, and use in critical applications of Texas Instruments semiconductor products and disclaimers thereto appears at the end of this data sheet.

All trademarks are the property of their respective owners.

ELECTROSTATIC DISCHARGE SENSITIVITY

This integrated circuit can be damaged by ESD. Texas Instruments recommends that all integrated circuits be handled with appropriate precautions. Failure to observe proper handling and installation procedures can cause damage.

ESD damage can range from subtle performance degradation to complete device failure. Precision integrated circuits may be more susceptible to damage because very small parametric changes could cause the device not to meet its published specifications.

ABSOLUTE MAXIMUM RATINGS⁽¹⁾

Supply Voltage (+V _{DD} , +V _{DDP} , +V _{DDB})	+6.5V
Supply Voltage Differences (+V _{DD} , +V _{DDP})	±0.1V
GND Voltage Differences: GND, GNDP, GNDB	±0.1V
Digital Input Voltage	-0.3V to (V _{DD} + 0.3V)
Digital Output Voltage	-0.3V to (V _{DDB} + 0.3V)
Input Current (any pins except supply pins)	±10mA
Power Dissipation	300mW
Operating Temperature Range	-25°C to +85°C
Storage Temperature	-55°C to +125°C
Lead Temperature (soldering, 5s)	+260°C
Package Temperature (IR reflow, 10s)	+235°C

NOTE: (1) Stresses above those listed under Absolute Maximum Ratings may cause permanent damage to the device. Exposure to absolute maximum conditions for extended periods may affect device reliability.

PACKAGE INFORMATION⁽¹⁾

PRODUCT	PACKAGE	SPECIFIED TEMPERATURE RANGE	PACKAGE DESIGNATOR
PLL1700E	20-Lead SSOP	-25°C to +85°C	DB

NOTE: (1) For the most current package and ordering information, see the Package Option Addendum at the end of this data sheet, or see the TI web site at www.ti.com.

PIN CONFIGURATION

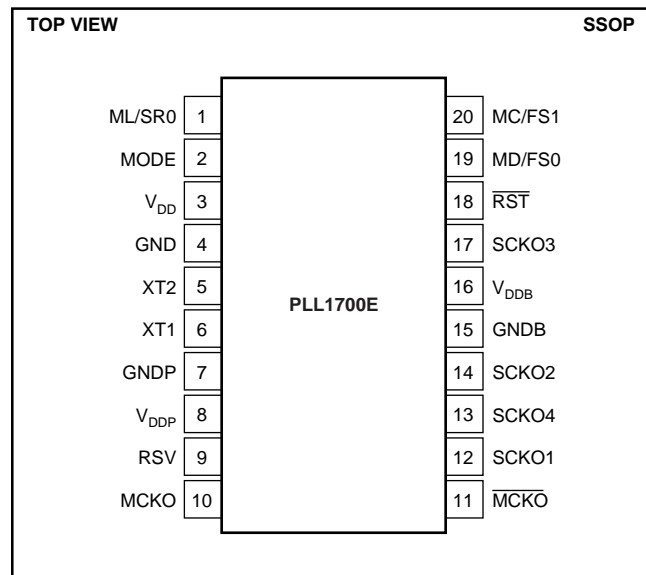

PIN ASSIGNMENTS

PIN	NAME	I/O	FUNCTION
1	ML/SR0	IN	Latch Enable for Software Mode/Sampling Rate Selection for Hardware Mode. When MODE pin is LOW, ML is selected. ⁽¹⁾
2	MODE	IN	Mode Control Select. When this pin is HIGH, device is operated in hardware mode using SR0 (pin 1), FS0 (pin 19), and FS1 (pin 20). When this pin is LOW, device is operated in software mode by three-wire interface using ML (pin 1), MD (pin 19) and MC (pin 20). ⁽¹⁾
3	V _{DD}	—	Digital Power Supply, +5V.
4	GND	—	Digital Ground.
5	XT2	—	27MHz Crystal. When an external 27MHz clock is applied to XT1 (pin 6), this pin must be connected to GND.
6	XT1	IN	27MHz Oscillator Input/External 27MHz Input.
7	GNDP	—	Ground for PLL.
8	V _{DDP}	—	Power Supply for PLL, +5V.
9	RSV	—	Reserved. Must be left open.
10	MCKO	OUT	27MHz Output.
11	MCKO-bar	OUT	Inverted 27MHz Output.
12	SCKO1	OUT	Fixed 33.8688MHz Clock Output.
13	SCKO4	OUT	768f _s Clock Output.
14	SCKO2	OUT	256f _s Clock Output.
15	GNDB	—	Digital Ground for V _{DDB} .
16	V _{DDB}	—	Digital Power Supply for Clock Output Buffers, +3.3V.
17	SCKO3	OUT	384f _s Output. This output has been optimized for the lowest jitter and should be connected to the audio DAC(s).
18	RST-bar	IN	Reset. When this pin is LOW, device is held in reset. ⁽¹⁾
19	MD/FS0	IN	Serial Data Input for Software Mode/Sampling Frequency Selection for Hardware Mode. When MODE pin is LOW, MD is selected. ⁽¹⁾
20	MC/FS1	IN	Shift Clock Input for Software Mode/Sampling Frequency Selection for Hardware Mode. When MODE pin is LOW, MC is selected. ⁽¹⁾

NOTE: (1) Schmitt-trigger input with internal pull-down resistors.

ELECTRICAL CHARACTERISTICS

All specifications at $T_A = +25^\circ\text{C}$, $V_{DD} = V_{DDP} = +5\text{V}$, $V_{DDB} = +3.3\text{V}$, $f_M = 27\text{MHz}$ crystal oscillation, and $f_S = 48\text{kHz}$, unless otherwise noted.

PARAMETER	CONDITIONS	PLL1700E			UNITS
		MIN	TYP	MAX	
DIGITAL INPUT/OUTPUT Input Logic Level: $V_{IH}^{(1)}$ $V_{IL}^{(1)}$ $V_{IH}^{(2)}$ $V_{IL}^{(2)}$ Input Logic Current: $I_{IH}^{(1)}$ $I_{IL}^{(1)}$ $I_{IH}^{(2)}$ $I_{IL}^{(2)}$ Output Logic Level: $V_{OH}^{(3)}$ $V_{OL}^{(3)}$ Sampling Frequency (f_S)			TTL-Compatible		
		2.0		0.8	VDC
		1.2		0.4	VDC
				200	μA
				-1	μA
				4	mA
				-800	μA
			CMOS		
			$V_{DDB} - 0.4\text{V}$		VDC
				0.4	VDC
		32	44.1	48	kHz
		64	88.2	96	kHz
MASTER CLOCK (MCKO, $\overline{\text{MCKO}}$) Master Clock Frequency Clock Jitter ⁽⁴⁾ Clock Duty Cycle $\overline{\text{MCKO}}$ For Crystal Oscillation $\overline{\text{MCKO}}$ Clock Duty Cycle $\overline{\text{MCKO}}$ For External Clock $\overline{\text{MCKO}}$	$f_M = 27\text{MHz}$, $C_L = 20\text{pF}$	26.73	27	27.27	MHz
	$C_1 = C_2 = 15\text{pF}$	40	50	60	ps
		40	50	60	%
		40	50	60	%
			60	60	%
PHASE LOCK LOOP (PLL) Generated System Clock Frequency SCKO1 SCKO2 SCKO3 SCKO4 Generated Clock Rise Time ⁽³⁾ Generated Clock Fall Time ⁽³⁾ Generated Clock Duty Cycle Generated Clock Jitter ⁽⁴⁾ Settling Time Power-Up Time	$f_M = 27\text{MHz}$, $C_L = 20\text{pF}$		33.8688		MHz
	Fixed	8.192		24.576	MHz
	$256f_S$	12.288		36.864	MHz
	$384f_S$	24.576		36.864	MHz
	$768f_S$		5		ns
	20% to 80% V_{DDB}		5		ns
	80% to 20% V_{DDB}		40	60	%
	SCKO1, SCKO3, SCKO4		40	60	%
	SCKO2 (standard)		40	60	%
	SCKO2 (double) ⁽⁵⁾		25	40	%
	SCKO1, SCKO2 (standard), SCKO4		300		ps
	SCKO3		150		ps
SCKO2 (double)		450		ps	
To Programmed Frequency			20	ms	
To Programmed Frequency			15	ms	
POWER SUPPLY REQUIREMENTS Voltage Range Supply Current ⁽⁶⁾ : $I_{DD} + I_{DDP}$ I_{DDB} Power Dissipation	V_{DD}, V_{DDP} V_{DDB}	+4.5 +2.7	+5 +3.3	+5.5 +3.6	VDC VDC
	$V_{DD} = V_{DDP} = 5\text{V}$, $f_S = 48\text{kHz}$		11	16	mA
	$V_{DDB} = +3.3\text{V}$, $f_S = 48\text{kHz}$		6	9	mA
	$f_S = 48\text{kHz}$		75	110	mW
TEMPERATURE RANGE Operation Storage		-25 -55		+85 +125	$^\circ\text{C}$ $^\circ\text{C}$

NOTES: (1) ML, MC, MD, MODE, $\overline{\text{RST}}$ (Schmitt-trigger input with internal pull-down resistor).

(2) XT1, when an external 27MHz clock is used, the buffer ICs, such as 74HC04, are recommended to interface to XT1.

(3) $\overline{\text{MCKO}}$, $\overline{\text{MCKO}}$, SCKO4, SCKO3, SCKO2, and SCKO1.

(4) Jitter performance is specified as standard deviation of jitter under 27MHz crystal oscillation.

(5) When SCKO2 is set to double rate clock output, its duty cycle is 33%.

(6) $f_M = 27\text{MHz}$ crystal oscillation, no load on $\overline{\text{MCKO}}$, $\overline{\text{MCKO}}$, SCKO4, SCKO3, SCKO2, and SCKO1.

TYPICAL CHARACTERISTICS

At $T_A = +25^\circ\text{C}$, $V_{DD} = V_{DDP} = +5\text{V}$, $V_{DDB} = +3.3\text{V}$, $C_L = 20\text{pF}$, unless otherwise noted.

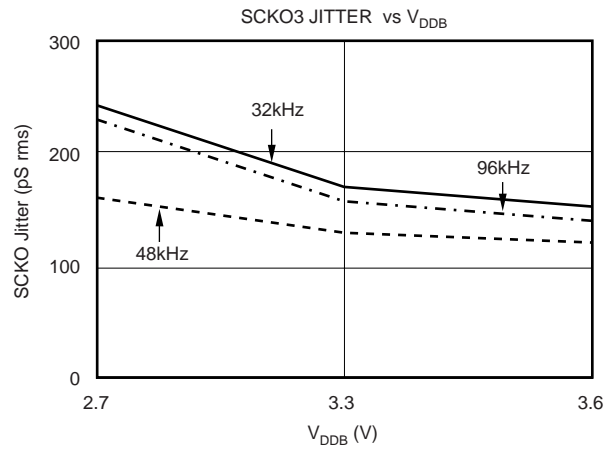
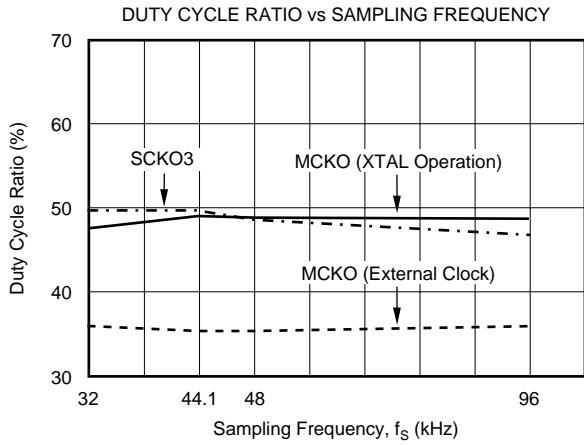
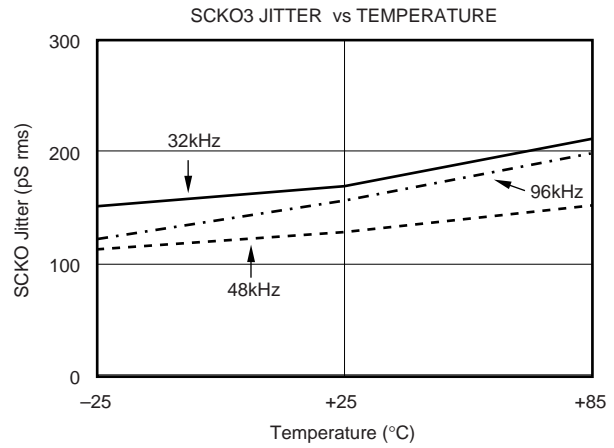
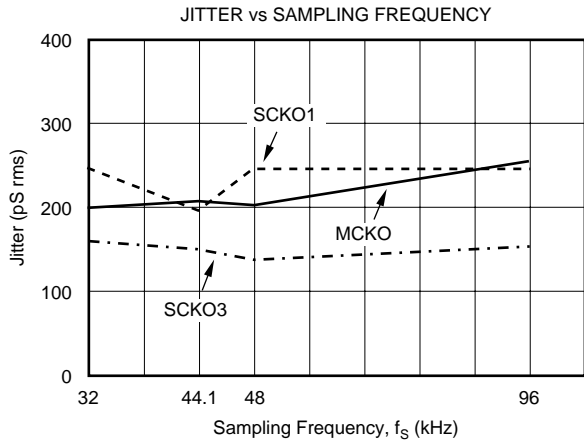

THEORY OF OPERATION

MASTER CLOCK AND SYSTEM CLOCK OUTPUT

The PLL1700 consists of a dual PLL clock and master clock generator which generates four system clocks and two buffered 27MHz clocks from a 27MHz master clock. Figure 1 shows the block diagram of the PLL1700. The PLL is designed to accept a 27MHz master clock or crystal oscillator. The master clock can be either a crystal

oscillator placed between XT1 (pin 6) and XT2 (pin 5), or an external input to XT1. If an external master clock is used, XT2 must be connected to ground. In both cases, the signal amplitude on XT1 must satisfy the specification described in Figure 3. Therefore, careful C_1 and C_2 determination is required for keeping this specification when using a crystal oscillator.

Figure 2 illustrates possible system clock connection options. Figure 3 illustrates the 27MHz master clock timing requirements.

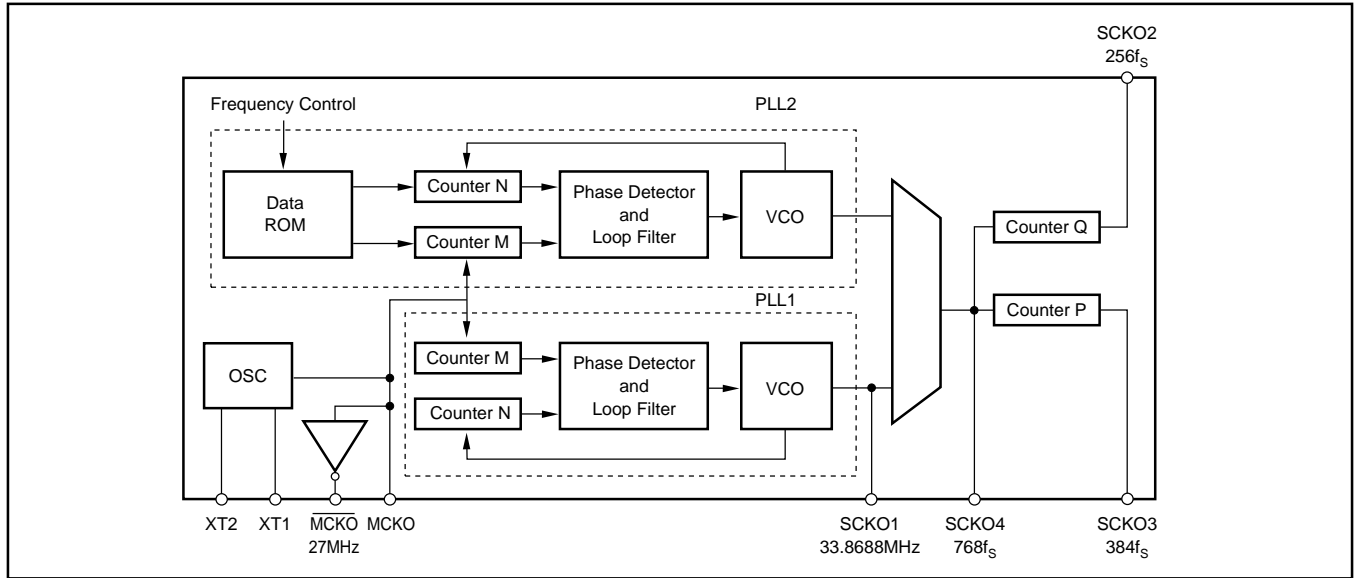

FIGURE 1. Block Diagram of PLL1700.

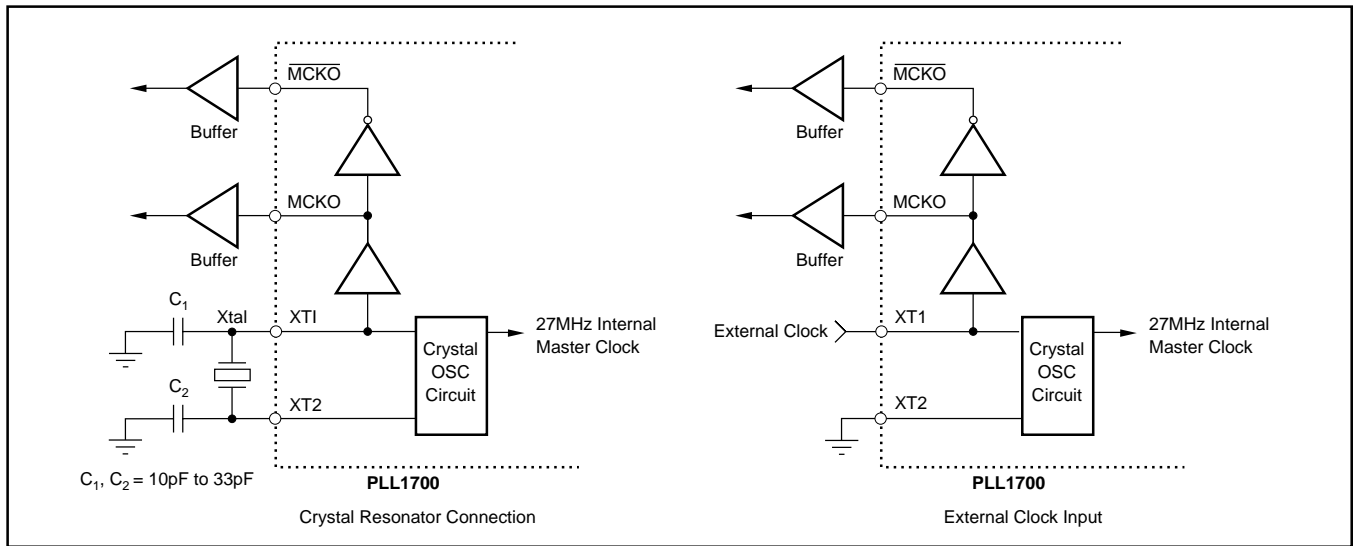

FIGURE 2. Master Clock Generator Connection Diagram.

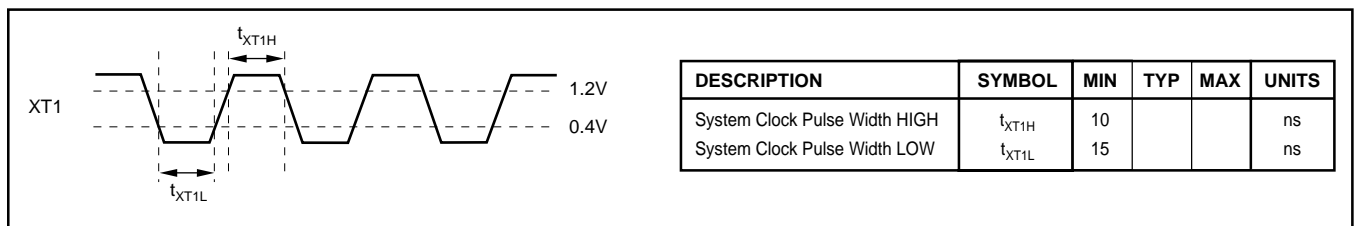

FIGURE 3. External Master Clock Timing Requirement.

The PLL1700 provides a very low jitter, high accuracy clock. SCKO1 is a fixed frequency clock which is 33.8688MHz (768 x 44.1kHz) for a CD-DA DSP. The output frequency of the remaining clocks is determined by the sampling frequency (f_s) by software or hardware control. SCKO2 and SCKO3 output $256f_s$ and $384f_s$ systems clocks, respectively. SCKO4 output is $768f_s$ if the sampling frequency is 32kHz, 44.1kHz, 48kHz, or the output is $384f_s$ if the sampling frequency is 64kHz, 88.2kHz, or 96kHz. Table I shows each sampling frequency. The system clock output frequencies are generated by a 27MHz master clock and programmed sampling frequencies are shown in Table II.

SAMPLING RATE	SAMPLING FREQUENCY (kHz)		
	Standard Sampling Frequencies	32	44.1
Double of Standard Sampling Frequencies	64	88.2	96

TABLE I. Sampling Frequencies.

SAMPLING FREQUENCY (kHz)	SAMPLING RATE	SCKO2 (MHz)	SCKO3 (MHz)	SCKO4 (MHz)
32	Standard	8.192	12.288	24.576
44.1	Standard	11.2896	16.9344	33.8688
48	Standard	12.288	18.4320	36.8640
64	Double	16.384	24.576	24.576
88.2	Double	22.5792	33.8688	33.8688
96	Double	24.576	36.8640	36.8640

TABLE II. Sampling Frequencies and Master Clock Output Frequencies.

Response time from power-on (or applying the clock to XT1) to SCKO settling time is typically 15ms. Delay time from sampling frequency change to SCKO settling time is 20ms maximum. Figure 4 illustrates SCKO transient timing.

External buffers are recommended on all output clocks in order to avoid degrading the jitter performance of the PLL1700.

RESET

The PLL1700 has an internal power-on reset circuit, as well as an external forced reset (RST, pin 18). Both resets have the same effect on the PLL1700 functions. The mode register default settings for software mode are initialized by reset. Throughout the reset period, all clock outputs are enabled with the default settings. Initialization for the internal power-on reset is done automatically during 1024 master clocks at $V_{DD} \geq 2.2V$ (1.8V to 2.6V). When using the internal power-on reset, RST should be HIGH. Power-on reset timing is shown in Figure 5. RST (pin 18) accepts an external forced reset by RST = L. Initialization (reset) is done when RST = L and 1024 master clocks after RST = H. External reset timing is shown in Figures 6 and 7.

FUNCTION CONTROL

The built-in function of the PLL1700 can be controlled in the software mode (serial mode), which uses a three-wire interface by ML (pin 1), MC (pin 20), and MD (pin 19), when MODE (pin 2) = L. They can also be controlled in the hardware mode (parallel mode) which uses SR0 (pin 1), FS1 (pin 20) and FS0 (pin 19), when MODE (pin 2) = H. The selectable functions are shown in Table III.

FUNCTION	HARDWARE MODE (MODE = H)	SOFTWARE MODE (MODE = L)
Sampling Frequency Select (32kHz, 44.1kHz, 48kHz)	Yes	Yes
Sampling Rate Select (Standard/Double)	Yes	Yes
Each Clock Output Enable/Disable	No	Yes

TABLE III. Selectable Functions.

HARDWARE MODE (MODE = H)

In the hardware mode, the following functions can be selected:

Sampling Group Select

The sampling frequency group can be selected by FS1 (pin 20) and FS0 (pin 19). This selection must be made with an interval time greater than 20 μ s.

FS1 (Pin 20)	FS0 (Pin 19)	SAMPLING GROUP
L	L	48kHz
L	H	44.1kHz
H	L	32kHz
H	H	Reserved

Sampling Rate Select

The sampling rate can be selected by SR0 (pin 1).

SR0 (Pin 1)	SAMPLING RATE SELECT
L	Standard
H	Double

SOFTWARE MODE (MODE = L)

The PLL1700 special function in software mode is shown in Table IV. These functions are controlled using ML, MC, and MD serial control signal.

FUNCTION	DEFAULT
Sampling Frequency Select (32kHz, 44.1kHz, 48kHz)	48kHz Group
Sampling Rate Select (Standard/Double)	Standard
Each Clock Output Enable/Disable	Enable

TABLE IV. Selectable Functions.

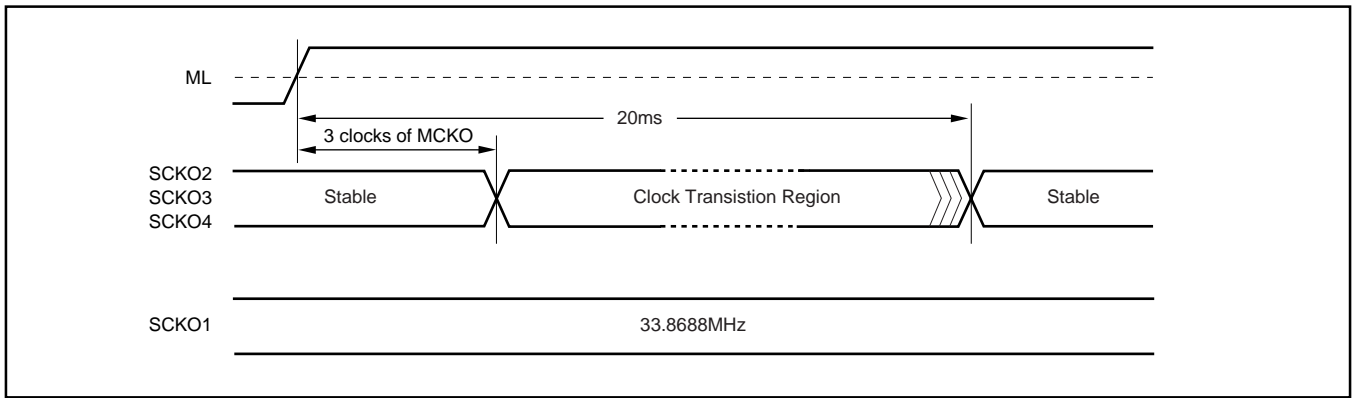

FIGURE 4. System Clock Transient Timing Chart.

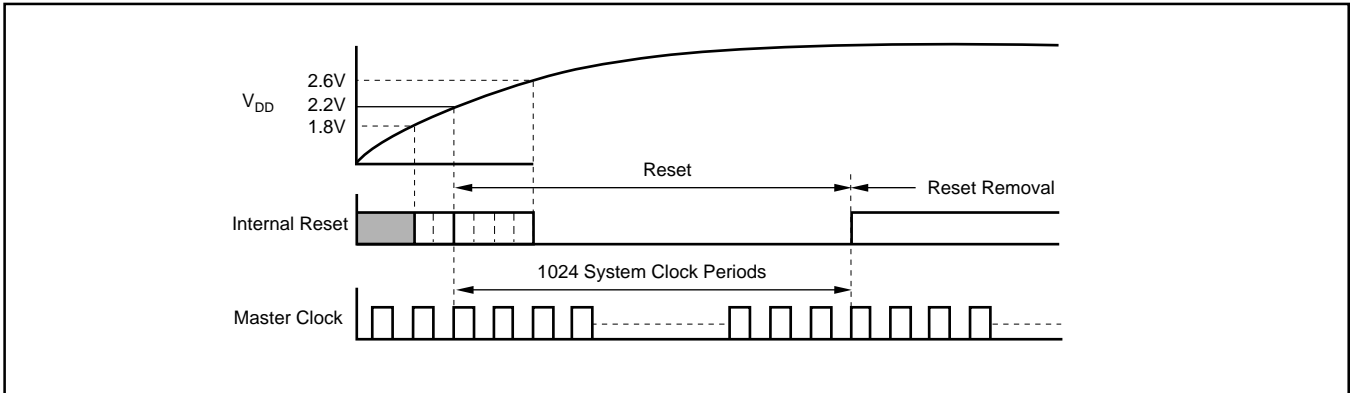

FIGURE 5. Power-On Reset Timing.

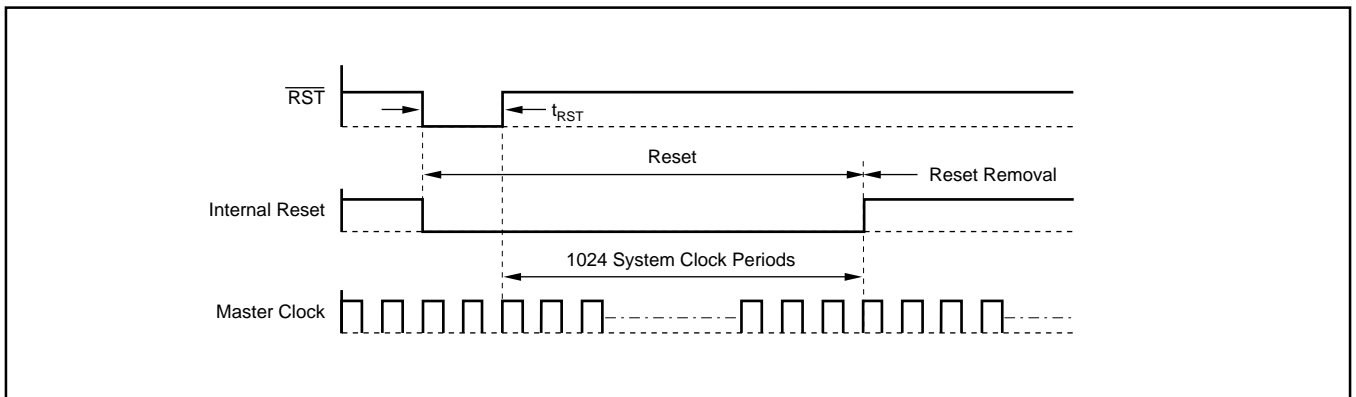

FIGURE 6. External Reset Timing.

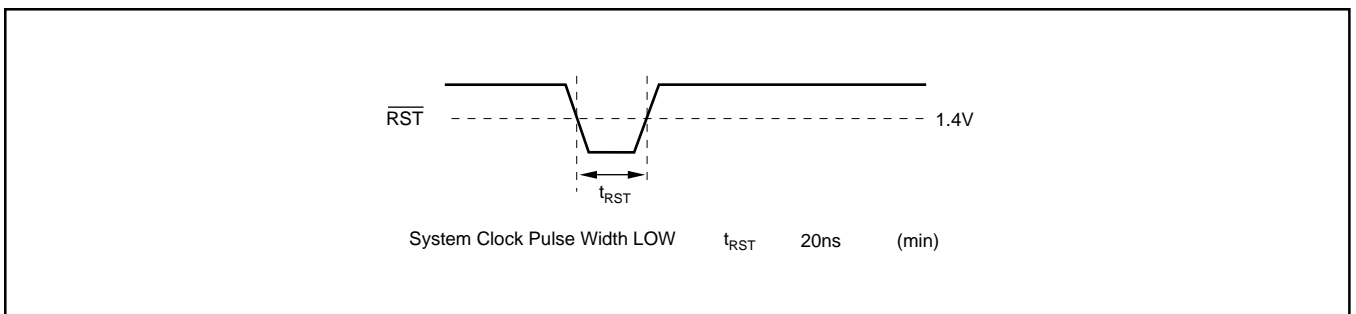

FIGURE 7. Reset Pulse Timing Requirement.

CONNECTION DIAGRAM

Figure 10 shows the typical connection circuit for the PLL1700. There are three grounds for digital, analog and PLL power supply. However, the use of one common ground connection is recommended to avoid latch-up problems. Power supplies should be bypassed as close as possible to the device.

MPEG-2 APPLICATIONS

Typical applications for the PLL1700 are MPEG-2 based systems such as DVD players, DVD add-on cards for multimedia PCs, digital HDTV systems, and set-top boxes. The PLL1700 provides audio system clocks for a CD-DA DSP, DVD DSP, Karaoke DSP, and DAC(s) from a 27MHz video clock.

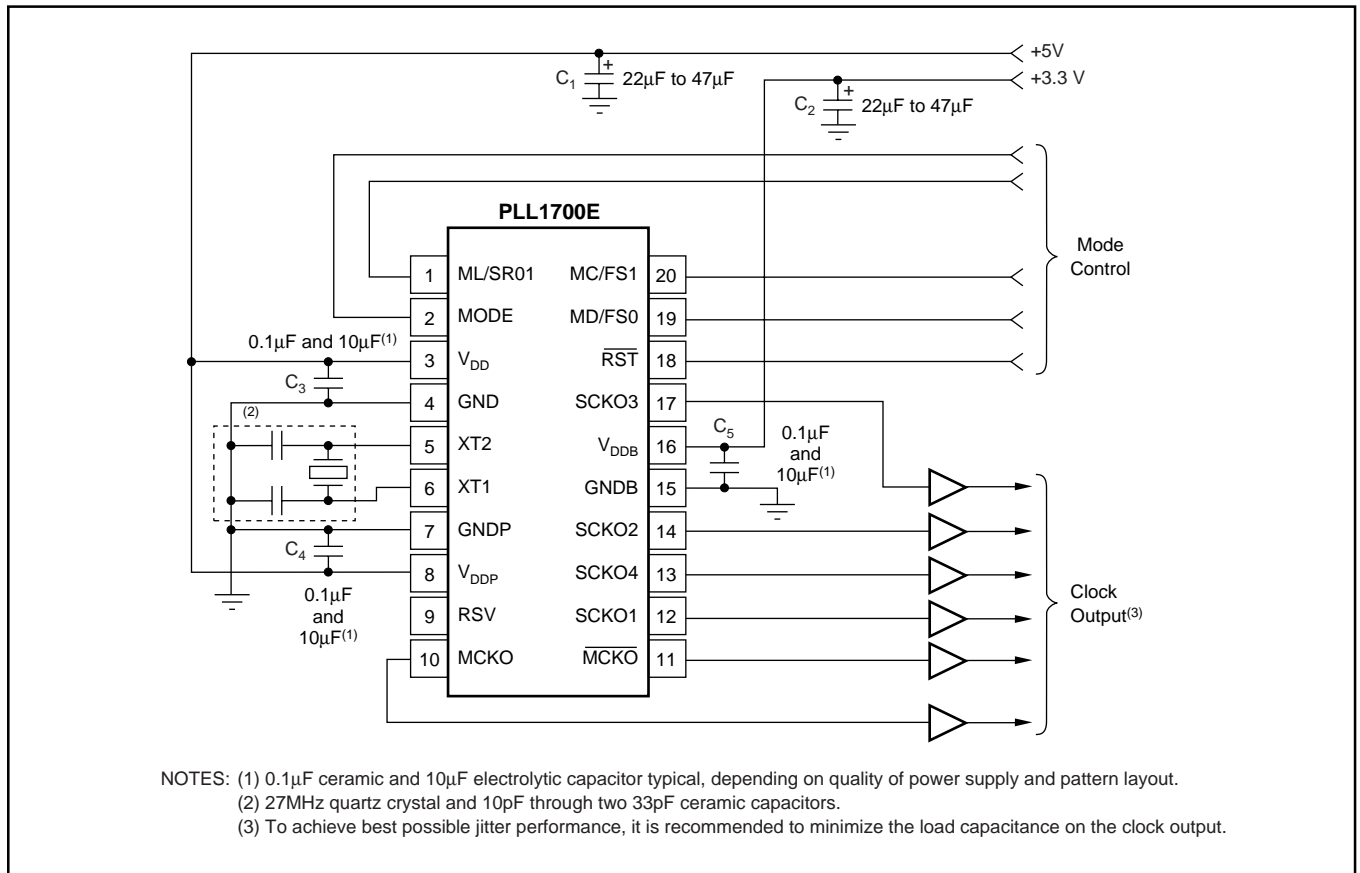

FIGURE 10. Typical Connection Diagram.

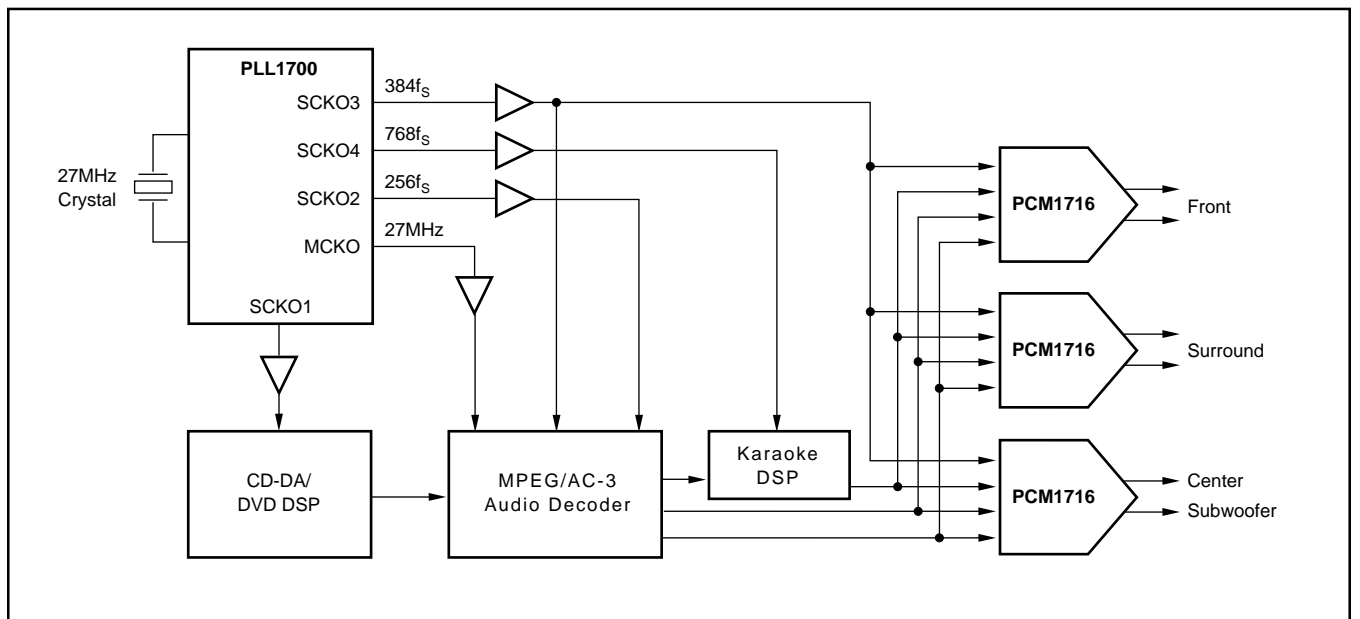

FIGURE 11. PLL1700 System Application Block Diagram.

Revision History

DATE	REVISION	PAGE	SECTION	DESCRIPTION
5/07	A	—	Entire Document	Updated format to current standard look.
		3	Electrical Characteristics	Added note (1) to V_{IH} and V_{IL} .
				Added two rows to <i>Input Logic Level</i> for V_{IH} and V_{IL} with note (2). Added condition to <i>Clock Duty Cycle</i> row stating that $C_1 = C_2 = 15\text{pF}$.
		5	Master Clock and System Clock Output	Changed "X2 should be connected" to "X2 must be connected."
				Added text regarding signal amplitude.
		5	Figure 5	Changed voltage from 2.0V to 1.2V.
				Changed voltage from 0.8V to 0.4V.
				Changed t_{XT1H} min value from 15 to 10.
		6	Sampling Group Select	Added text regarding interval time.
		8	Mode Register	Added text regarding interval time.
9	Figure 10	Deleted note (1) from C_1 and C_2 .		
		Changed note text from "tantalum" to "electrolytic" capacitor.		

NOTE: Page numbers for previous revisions may differ from page numbers in the current version.

PACKAGING INFORMATION

Orderable Device	Status ⁽¹⁾	Package Type	Package Drawing	Pins	Package Qty	Eco Plan ⁽²⁾	Lead/Ball Finish	MSL Peak Temp ⁽³⁾
PLL1700E	ACTIVE	SSOP	DB	20	65	Green (RoHS & no Sb/Br)	CU NIPDAU	Level-1-260C-UNLIM
PLL1700E/2K	ACTIVE	SSOP	DB	20	2000	Green (RoHS & no Sb/Br)	CU NIPDAU	Level-1-260C-UNLIM
PLL1700E/2KG4	ACTIVE	SSOP	DB	20	2000	Green (RoHS & no Sb/Br)	CU NIPDAU	Level-1-260C-UNLIM
PLL1700EG	ACTIVE	SSOP	DB	20	65	Pb-Free (RoHS)	CU SNBI	Level-1-260C-UNLIM
PLL1700EG/2K	ACTIVE	SSOP	DB	20	2000	Pb-Free (RoHS)	CU SNBI	Level-1-260C-UNLIM
PLL1700EG/2KE6	ACTIVE	SSOP	DB	20	2000	Pb-Free (RoHS)	CU SNBI	Level-1-260C-UNLIM
PLL1700EG4	ACTIVE	SSOP	DB	20	65	Green (RoHS & no Sb/Br)	CU NIPDAU	Level-1-260C-UNLIM
PLL1700EGE6	ACTIVE	SSOP	DB	20	65	Pb-Free (RoHS)	CU SNBI	Level-1-260C-UNLIM

⁽¹⁾ The marketing status values are defined as follows:

ACTIVE: Product device recommended for new designs.

LIFEBUY: TI has announced that the device will be discontinued, and a lifetime-buy period is in effect.

NRND: Not recommended for new designs. Device is in production to support existing customers, but TI does not recommend using this part in a new design.

PREVIEW: Device has been announced but is not in production. Samples may or may not be available.

OBSOLETE: TI has discontinued the production of the device.

⁽²⁾ Eco Plan - The planned eco-friendly classification: Pb-Free (RoHS), Pb-Free (RoHS Exempt), or Green (RoHS & no Sb/Br) - please check <http://www.ti.com/productcontent> for the latest availability information and additional product content details.

TBD: The Pb-Free/Green conversion plan has not been defined.

Pb-Free (RoHS): TI's terms "Lead-Free" or "Pb-Free" mean semiconductor products that are compatible with the current RoHS requirements for all 6 substances, including the requirement that lead not exceed 0.1% by weight in homogeneous materials. Where designed to be soldered at high temperatures, TI Pb-Free products are suitable for use in specified lead-free processes.

Pb-Free (RoHS Exempt): This component has a RoHS exemption for either 1) lead-based flip-chip solder bumps used between the die and package, or 2) lead-based die adhesive used between the die and leadframe. The component is otherwise considered Pb-Free (RoHS compatible) as defined above.

Green (RoHS & no Sb/Br): TI defines "Green" to mean Pb-Free (RoHS compatible), and free of Bromine (Br) and Antimony (Sb) based flame retardants (Br or Sb do not exceed 0.1% by weight in homogeneous material)

⁽³⁾ MSL, Peak Temp. -- The Moisture Sensitivity Level rating according to the JEDEC industry standard classifications, and peak solder temperature.

Important Information and Disclaimer:The information provided on this page represents TI's knowledge and belief as of the date that it is provided. TI bases its knowledge and belief on information provided by third parties, and makes no representation or warranty as to the accuracy of such information. Efforts are underway to better integrate information from third parties. TI has taken and continues to take reasonable steps to provide representative and accurate information but may not have conducted destructive testing or chemical analysis on incoming materials and chemicals. TI and TI suppliers consider certain information to be proprietary, and thus CAS numbers and other limited information may not be available for release.

In no event shall TI's liability arising out of such information exceed the total purchase price of the TI part(s) at issue in this document sold by TI to Customer on an annual basis.

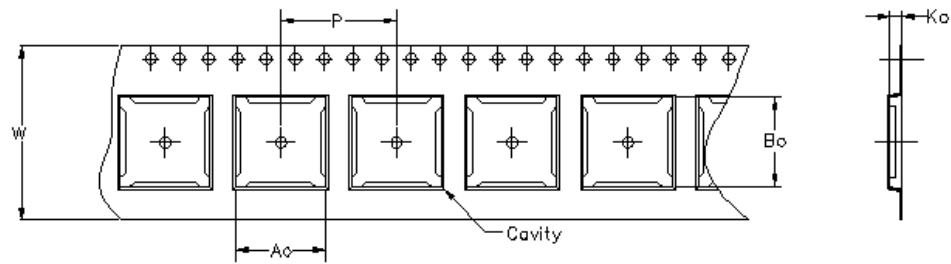

Carrier tape design is defined largely by the component length, width, and thickness.

A_o = Dimension designed to accommodate the component width.
B_o = Dimension designed to accommodate the component length.
K_o = Dimension designed to accommodate the component thickness.
W = Overall width of the carrier tape.
P = Pitch between successive cavity centers.

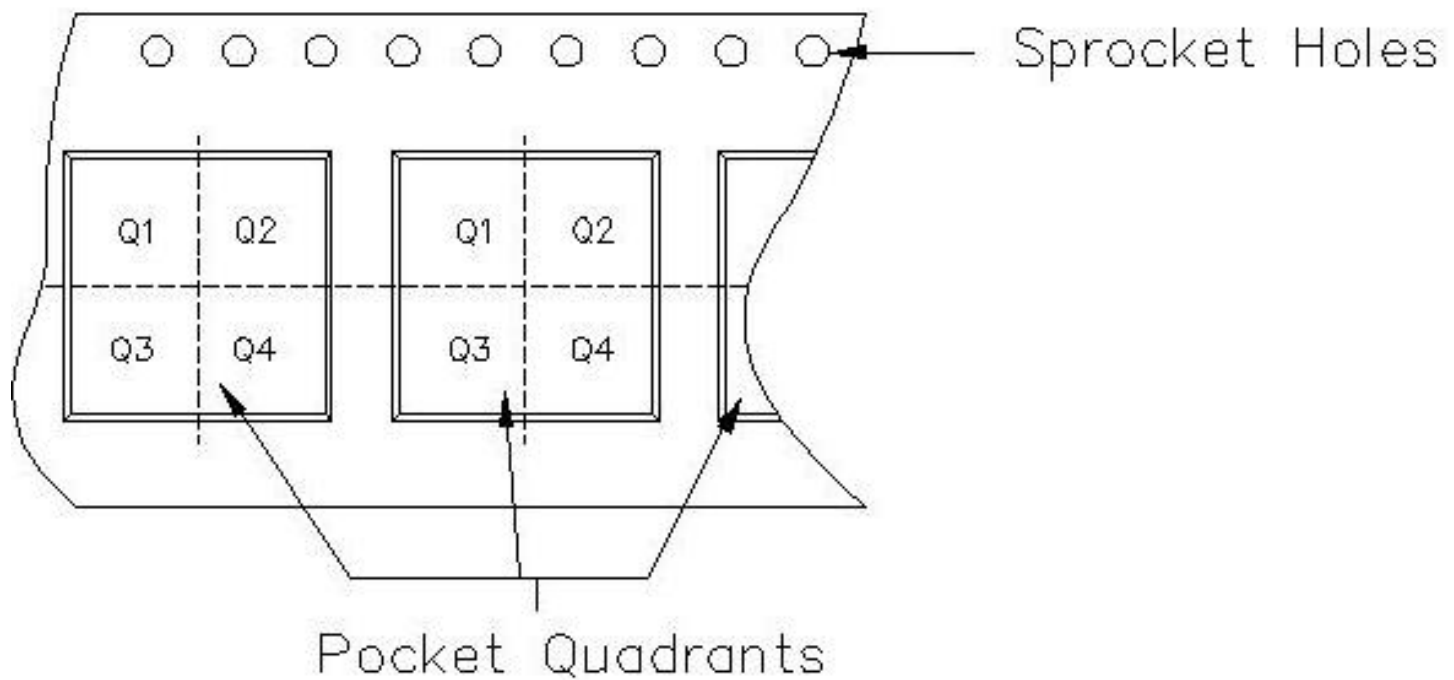

TAPE AND REEL INFORMATION

Device	Package	Pins	Site	Reel Diameter (mm)	Reel Width (mm)	A0 (mm)	B0 (mm)	K0 (mm)	P1 (mm)	W (mm)	Pin1 Quadrant
PLL1700E/2K	DB	20	SITE 49	330	17	8.5	7.6	2.4	12	16	Q1
PLL1700EG/2K	DB	20	SITE 49	330	17	8.5	7.6	2.4	12	16	Q1

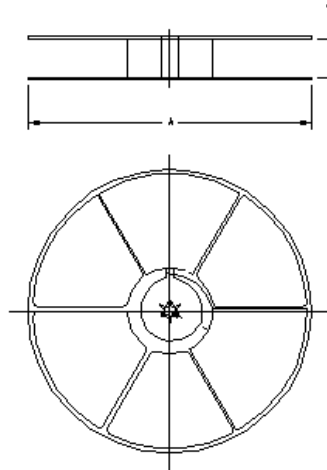

TAPE AND REEL BOX INFORMATION

Device	Package	Pins	Site	Length (mm)	Width (mm)	Height (mm)
PLL1700E/2K	DB	20	SITE 49	0.0	0.0	0.0
PLL1700EG/2K	DB	20	SITE 49	0.0	0.0	0.0

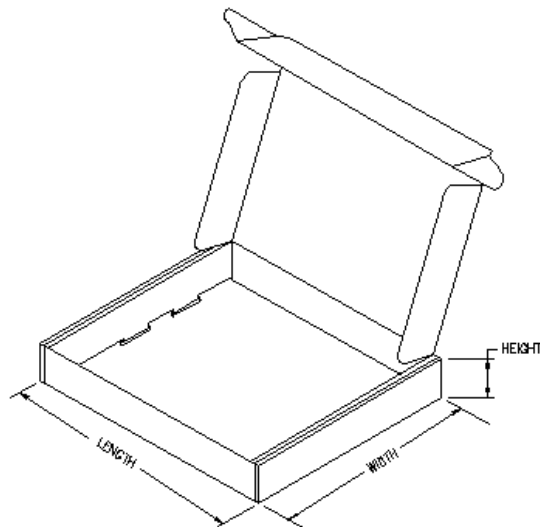

IMPORTANT NOTICE

Texas Instruments Incorporated and its subsidiaries (TI) reserve the right to make corrections, modifications, enhancements, improvements, and other changes to its products and services at any time and to discontinue any product or service without notice. Customers should obtain the latest relevant information before placing orders and should verify that such information is current and complete. All products are sold subject to TI's terms and conditions of sale supplied at the time of order acknowledgment.

TI warrants performance of its hardware products to the specifications applicable at the time of sale in accordance with TI's standard warranty. Testing and other quality control techniques are used to the extent TI deems necessary to support this warranty. Except where mandated by government requirements, testing of all parameters of each product is not necessarily performed.

TI assumes no liability for applications assistance or customer product design. Customers are responsible for their products and applications using TI components. To minimize the risks associated with customer products and applications, customers should provide adequate design and operating safeguards.

TI does not warrant or represent that any license, either express or implied, is granted under any TI patent right, copyright, mask work right, or other TI intellectual property right relating to any combination, machine, or process in which TI products or services are used. Information published by TI regarding third-party products or services does not constitute a license from TI to use such products or services or a warranty or endorsement thereof. Use of such information may require a license from a third party under the patents or other intellectual property of the third party, or a license from TI under the patents or other intellectual property of TI.

Reproduction of TI information in TI data books or data sheets is permissible only if reproduction is without alteration and is accompanied by all associated warranties, conditions, limitations, and notices. Reproduction of this information with alteration is an unfair and deceptive business practice. TI is not responsible or liable for such altered documentation. Information of third parties may be subject to additional restrictions.

Resale of TI products or services with statements different from or beyond the parameters stated by TI for that product or service voids all express and any implied warranties for the associated TI product or service and is an unfair and deceptive business practice. TI is not responsible or liable for any such statements.

TI products are not authorized for use in safety-critical applications (such as life support) where a failure of the TI product would reasonably be expected to cause severe personal injury or death, unless officers of the parties have executed an agreement specifically governing such use. Buyers represent that they have all necessary expertise in the safety and regulatory ramifications of their applications, and acknowledge and agree that they are solely responsible for all legal, regulatory and safety-related requirements concerning their products and any use of TI products in such safety-critical applications, notwithstanding any applications-related information or support that may be provided by TI. Further, Buyers must fully indemnify TI and its representatives against any damages arising out of the use of TI products in such safety-critical applications.

TI products are neither designed nor intended for use in military/aerospace applications or environments unless the TI products are specifically designated by TI as military-grade or "enhanced plastic." Only products designated by TI as military-grade meet military specifications. Buyers acknowledge and agree that any such use of TI products which TI has not designated as military-grade is solely at the Buyer's risk, and that they are solely responsible for compliance with all legal and regulatory requirements in connection with such use.

TI products are neither designed nor intended for use in automotive applications or environments unless the specific TI products are designated by TI as compliant with ISO/TS 16949 requirements. Buyers acknowledge and agree that, if they use any non-designated products in automotive applications, TI will not be responsible for any failure to meet such requirements.

Following are URLs where you can obtain information on other Texas Instruments products and application solutions:

Products		Applications	
Amplifiers	amplifier.ti.com	Audio	www.ti.com/audio
Data Converters	dataconverter.ti.com	Automotive	www.ti.com/automotive
DSP	dsp.ti.com	Broadband	www.ti.com/broadband
Interface	interface.ti.com	Digital Control	www.ti.com/digitalcontrol
Logic	logic.ti.com	Military	www.ti.com/military
Power Mgmt	power.ti.com	Optical Networking	www.ti.com/opticalnetwork
Microcontrollers	microcontroller.ti.com	Security	www.ti.com/security
RFID	www.ti-rfid.com	Telephony	www.ti.com/telephony
Low Power Wireless	www.ti.com/lpw	Video & Imaging	www.ti.com/video
		Wireless	www.ti.com/wireless

Mailing Address: Texas Instruments, Post Office Box 655303, Dallas, Texas 75265
Copyright © 2007, Texas Instruments Incorporated