

## FEATURES

- Low Standby-Current Consumption of 10  $\mu$ A Max
- I<sup>2</sup>C to Parallel-Port Expander
- Open-Drain Interrupt Output
- Compatible With Most Microcontrollers
- 400-kHz Fast I<sup>2</sup>C Bus
- Address by Three Hardware Address Pins for Use of up to Eight Devices
- Latched Outputs With High-Current Drive
- Capability for Directly Driving LEDs
- Current Source to V<sub>CC</sub> for Actively Driving a High at the Output
- Latch-Up Performance Exceeds 100 mA Per JESD 78, Class II
- ESD Protection Exceeds JESD 22
  - 2000-V Human-Body Model (A114-A)
  - 200-V Machine Model (A115-A)
  - 1000-V Charged-Device Model (C101)

DB, DBQ, DGV, DW, OR PW PACKAGE  
(TOP VIEW)

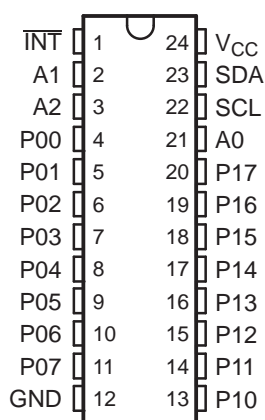

RGE PACKAGE  
(TOP VIEW)

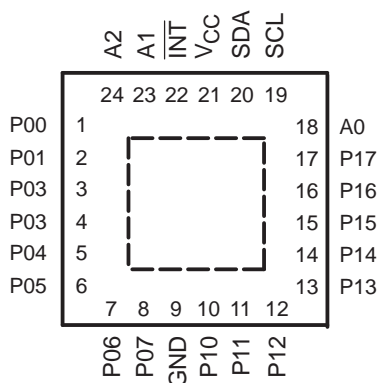

## DESCRIPTION/ORDERING INFORMATION

This 16-bit I/O expander for the two-line bidirectional bus (I<sup>2</sup>C) is designed for 2.5-V to 5.5-V V<sub>CC</sub> operation.

### ORDERING INFORMATION

T <sub>A</sub>	PACKAGE <sup>(1)</sup>		ORDERABLE PART NUMBER	TOP-SIDE MARKING
–40°C to 85°C	SSOP – DB	Reel of 2000	PCF8575DBR	PF575
	QSOP – DBQ	Reel of 2500	PCF8575DBQR	PCF8575
	TVSOP – DGV	Reel of 2000	PCF8575DGVR	PF575
	SOIC – DW	Tube of 25	PCF8575DW	PCF8575
		Reel of 2000	PCF8575DWR	
	TSSOP – PW	Tube of 60	PCF8575PW	PF575
		Reel of 1200	PCF8575PWR	
QFN – RGE	Reel of 3000	PCF8575RGER	PF575	

(1) Package drawings, standard packing quantities, thermal data, symbolization, and PCB design guidelines are available at [www.ti.com/sc/package](http://www.ti.com/sc/package).



Please be aware that an important notice concerning availability, standard warranty, and use in critical applications of Texas Instruments semiconductor products and disclaimers thereto appears at the end of this data sheet.

# PCF8575

## REMOTE 16-BIT I<sup>2</sup>C AND SMBus I/O EXPANDER WITH INTERRUPT OUTPUT

SCPS121D–JANUARY 2005–REVISED APRIL 2007

---

### DESCRIPTION/ORDERING INFORMATION (CONTINUED)

The PCF8575 provides general-purpose remote I/O expansion for most microcontroller families via the I<sup>2</sup>C interface serial clock (SCL) and serial data (SDA).

The device features a 16-bit quasi-bidirectional input/output (I/O) port (P07–P00, P17–P10), including latched outputs with high-current drive capability for directly driving LEDs. Each quasi-bidirectional I/O can be used as an input or output without the use of a data-direction control signal. At power on, the I/Os are high. In this mode, only a current source ( $I_{OH}$ ) to  $V_{CC}$  is active. An additional strong pullup to  $V_{CC}$  ( $I_{OHT}$ ) allows fast-rising edges into heavily loaded outputs. This device turns on when an output is written high and is switched off by the negative edge of SCL. The I/Os should be high before being used as inputs. After power on, as all the I/Os are set high, all of them can be used as inputs. Any change in setting of the I/Os as either input or outputs can be done with the write mode. If a high is applied externally to an I/O that has been written earlier to low, a large current ( $I_{OL}$ ) will flow to GND.

The PCF8575 provides an open-drain interrupt ( $\overline{INT}$ ) output, which can be connected to the interrupt input of a microcontroller. An interrupt is generated by any rising or falling edge of the port inputs in the input mode. After time,  $t_{iv}$ , the signal  $\overline{INT}$  is valid. Resetting and reactivating the interrupt circuit is achieved when data on the port is changed to the original setting, or data is read from or written to the port that generated the interrupt. Resetting occurs in the read mode at the acknowledge (ACK) bit after the rising edge of the SCL signal or in the write mode at the ACK bit after the falling edge of the SCL signal. Interrupts that occur during the ACK clock pulse can be lost (or be very short), due to the resetting of the interrupt during this pulse. Each change of the I/Os after resetting is detected and is transmitted as  $\overline{INT}$ . Reading from or writing to another device does not affect the interrupt circuit.

By sending an interrupt signal on this line, the remote I/O can inform the microcontroller if there is incoming data on its ports, without having to communicate via the I<sup>2</sup>C bus. Thus, the PCF8575 can remain a simple slave device.

Every data transmission to or from the PCF8575 must consist of an even number of bytes. The first data byte in every pair refers to port 0 (P07–P00), and the second data byte in every pair refers to port 1 (P17–P10). To write to the ports (output mode), the master first addresses the slave device, setting the last bit of the byte containing the slave address to logic 0. The PCF8575 acknowledges, and the master sends the first data byte for P07–P00. After the first data byte is acknowledged by the PCF8575, the second data byte (P17–P10) is sent by the master. Once again, the PCF8575 acknowledges the receipt of the data, after which this 16-bit data is presented on the port lines.

The number of data bytes that can be sent successively is not limited. After every two bytes, the previous data is overwritten. When the PCF8575 receives the pairs of data bytes, the first byte is referred to as P07–P00 and the second byte as P17–P10. The third byte is referred to as P07–P00, the fourth byte as P17–P10, and so on.

Before reading from the PCF8575, all ports desired as input should be set to logic 1. To read from the ports (input mode), the master first addresses the slave device, setting the last bit of the byte containing the slave address to logic 1. The data bytes that follow on the SDA are the values on the ports. If the data on the input port changes faster than the master can read, this data may be lost.

When power is applied to  $V_{CC}$ , an internal power-on reset holds the PCF8575 in a reset state until  $V_{CC}$  has reached  $V_{POR}$ . At that time, the reset condition is released, and the device I<sup>2</sup>C-bus state machine initializes the bus to its default state.

The hardware pins (A0, A1, and A2) are used to program and vary the fixed I<sup>2</sup>C address and allow up to eight devices to share the same I<sup>2</sup>C bus or SMBus. The fixed I<sup>2</sup>C address of the PCF8575 is the same as the PCF8575C, PCF8574, PCA9535, and PCA9555, allowing up to eight of these devices, in any combination, to share the same I<sup>2</sup>C bus or SMBus.

**TERMINAL FUNCTIONS**

NO.		NAME	FUNCTION
DB, DBQ, DGV, DW, AND PW	RGE		
1	22	INT	Interrupt output. Connect to V <sub>CC</sub> through a pullup resistor.
2	23	A1	Address input 1. Connect directly to V <sub>CC</sub> or ground. Pullup resistors are not needed.
3	24	A2	Address input 2. Connect directly to V <sub>CC</sub> or ground. Pullup resistors are not needed.
4	1	P00	P-port input/output. Push-pull design structure.
5	2	P01	P-port input/output. Push-pull design structure.
6	3	P02	P-port input/output. Push-pull design structure.
7	4	P03	P-port input/output. Push-pull design structure.
8	5	P04	P-port input/output. Push-pull design structure.
9	6	P05	P-port input/output. Push-pull design structure.
10	7	P06	P-port input/output. Push-pull design structure.
11	8	P07	P-port input/output. Push-pull design structure.
12	9	GND	Ground
13	10	P10	P-port input/output. Push-pull design structure.
14	11	P11	P-port input/output. Push-pull design structure.
15	12	P12	P-port input/output. Push-pull design structure.
16	13	P13	P-port input/output. Push-pull design structure.
17	14	P14	P-port input/output. Push-pull design structure.
18	15	P15	P-port input/output. Push-pull design structure.
19	16	P16	P-port input/output. Push-pull design structure.
20	17	P17	P-port input/output. Push-pull design structure.
21	18	A0	Address input 0. Connect directly to V <sub>CC</sub> or ground. Pullup resistors are not needed.
22	19	SCL	Serial clock line. Connect to V <sub>CC</sub> through a pullup resistor
23	20	SDA	Serial data line. Connect to V <sub>CC</sub> through a pullup resistor.
24	21	V <sub>CC</sub>	Supply voltage

# PCF8575 REMOTE 16-BIT I<sup>2</sup>C AND SMBus I/O EXPANDER WITH INTERRUPT OUTPUT

SCPS121D—JANUARY 2005—REVISED APRIL 2007

## LOGIC DIAGRAM (POSITIVE LOGIC)

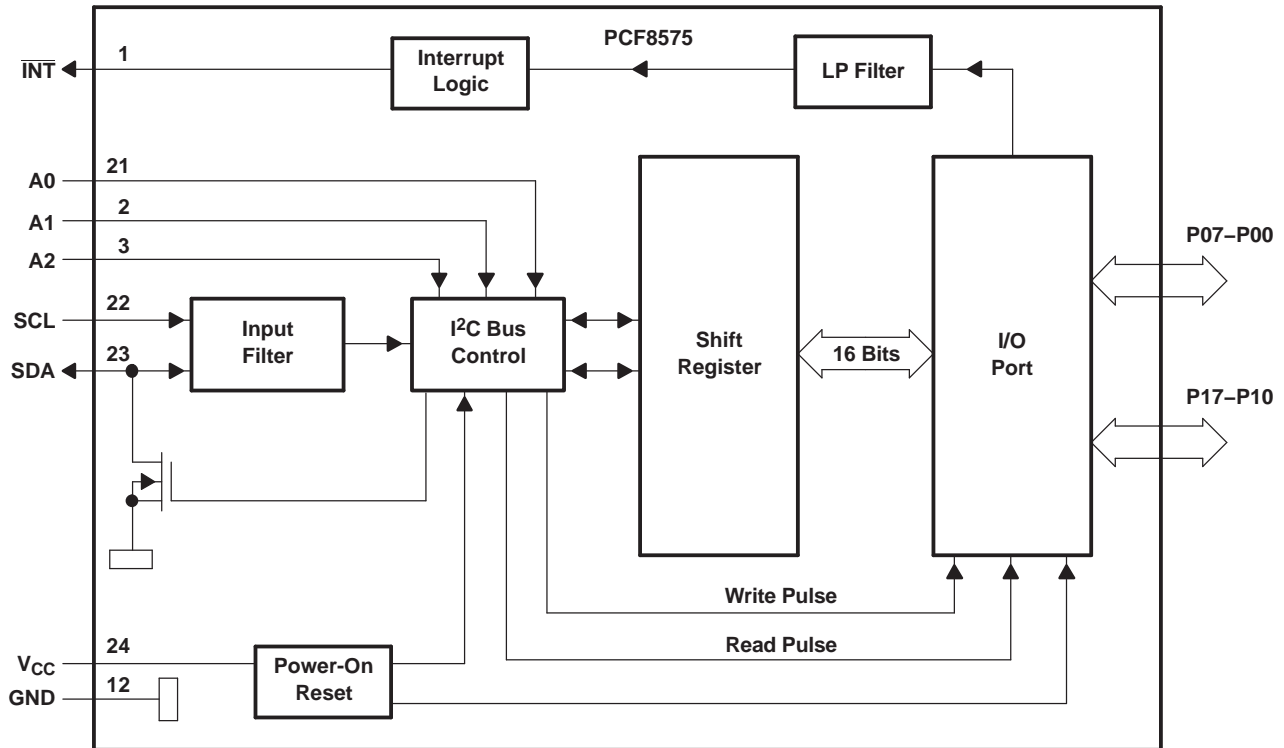

## SIMPLIFIED SCHEMATIC DIAGRAM OF EACH P-PORT INPUT/OUTPUT

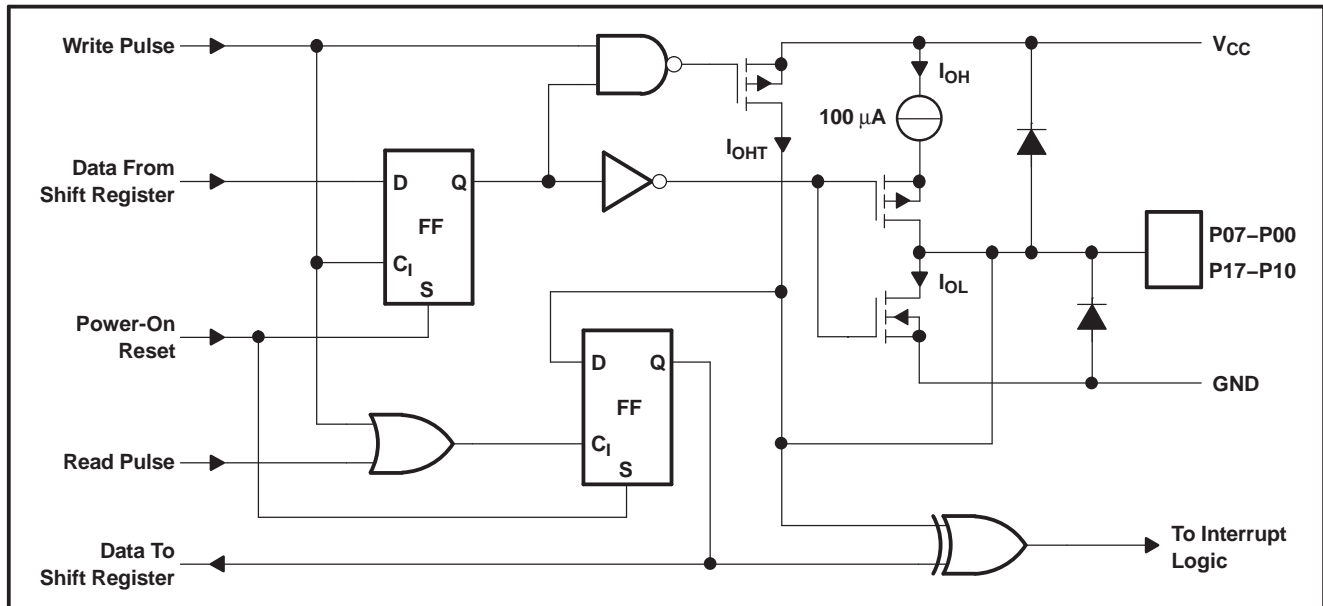

## I<sup>2</sup>C Interface

The bidirectional I<sup>2</sup>C bus consists of the serial clock (SCL) and serial data (SDA) lines. Both lines must be connected to a positive supply via a pullup resistor when connected to the output stages of a device. Data transfer may be initiated only when the bus is not busy.

I<sup>2</sup>C communication with this device is initiated by a master sending a Start condition, a high-to-low transition on the SDA input/output while the SCL input is high (see Figure 1). After the Start condition, the device address byte is sent, most significant bit (MSB) first, including the data direction bit ( $R/\overline{W}$ ). This device does not respond to the general call address. After receiving the valid address byte, this device responds with an ACK, a low on the SDA input/output during the high of the ACK-related clock pulse. The address inputs (A2–A0) of the slave device must not be changed between the Start and Stop conditions.

The data byte follows the address ACK. If the  $R/\overline{W}$  bit is high, the data from this device are the values read from the P port. If the  $R/\overline{W}$  bit is low, the data are from the master, to be output to the P port. The data byte is followed by an ACK sent from this device. If other data bytes are sent from the master, following the ACK, they are ignored by this device. Data are output only if complete bytes are received and acknowledged. The output data is valid at time ( $t_{pv}$ ) after the low-to-high transition of SCL, during the clock cycle for the ACK.

On the I<sup>2</sup>C bus, only one data bit is transferred during each clock pulse. The data on the SDA line must remain stable during the high pulse of the clock period, as changes in the data line at this time are interpreted as control commands (Start or Stop) (see Figure 2).

A Stop condition, a low-to-high transition on the SDA input/output while the SCL input is high, is sent by the master (see Figure 1).

The number of data bytes transferred between the Start and Stop conditions from transmitter to receiver is not limited. Each byte of eight bits is followed by one ACK bit. The transmitter must release the SDA line before the receiver can send an ACK bit.

A slave receiver that is addressed must generate an ACK after the reception of each byte. Also, a master must generate an ACK after the reception of each byte that has been clocked out of the slave transmitter. The device that acknowledges has to pull down the SDA line during the ACK clock pulse so that the SDA line is stable low during the high pulse of the ACK-related clock period (see Figure 3). Setup and hold times must be taken into account.

A master receiver must signal an end of data to the transmitter by not generating an acknowledge (NACK) after the last byte that has been clocked out of the slave. This is done by the master receiver by holding the SDA line high. In this event, the transmitter must release the data line to enable the master to generate a Stop condition.

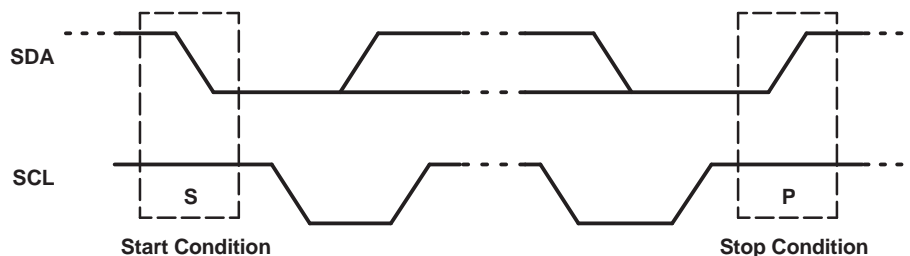

**Figure 1. Definition of Start and Stop Conditions**

**PCF8575**  
**REMOTE 16-BIT I<sup>2</sup>C AND SMBus I/O EXPANDER**  
**WITH INTERRUPT OUTPUT**

SCPS121D—JANUARY 2005—REVISED APRIL 2007

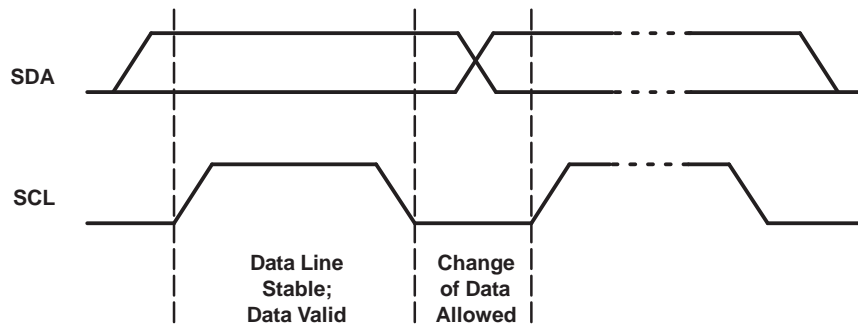

**Figure 2. Bit Transfer**

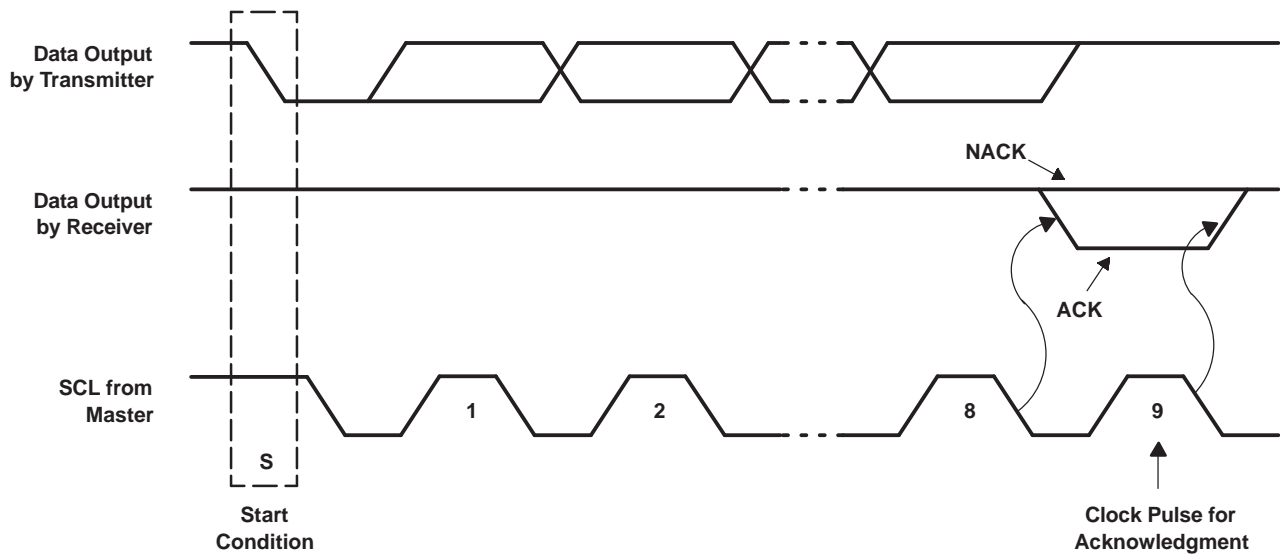

**Figure 3. Acknowledgment on I<sup>2</sup>C Bus**

**Interface Definition**

BYTE	BIT							
	7 (MSB)	6	5	4	3	2	1	0 (LSB)
I <sup>2</sup> C slave address	L	H	L	L	A2	A1	A0	R/W
P0x I/O data bus	P07	P06	P05	P04	P03	P02	P01	P00
P1x I/O data bus	P17	P16	P15	P14	P13	P12	P11	P10

Figure 4 and Figure 5 show the address and timing diagrams for the write and read modes, respectively.

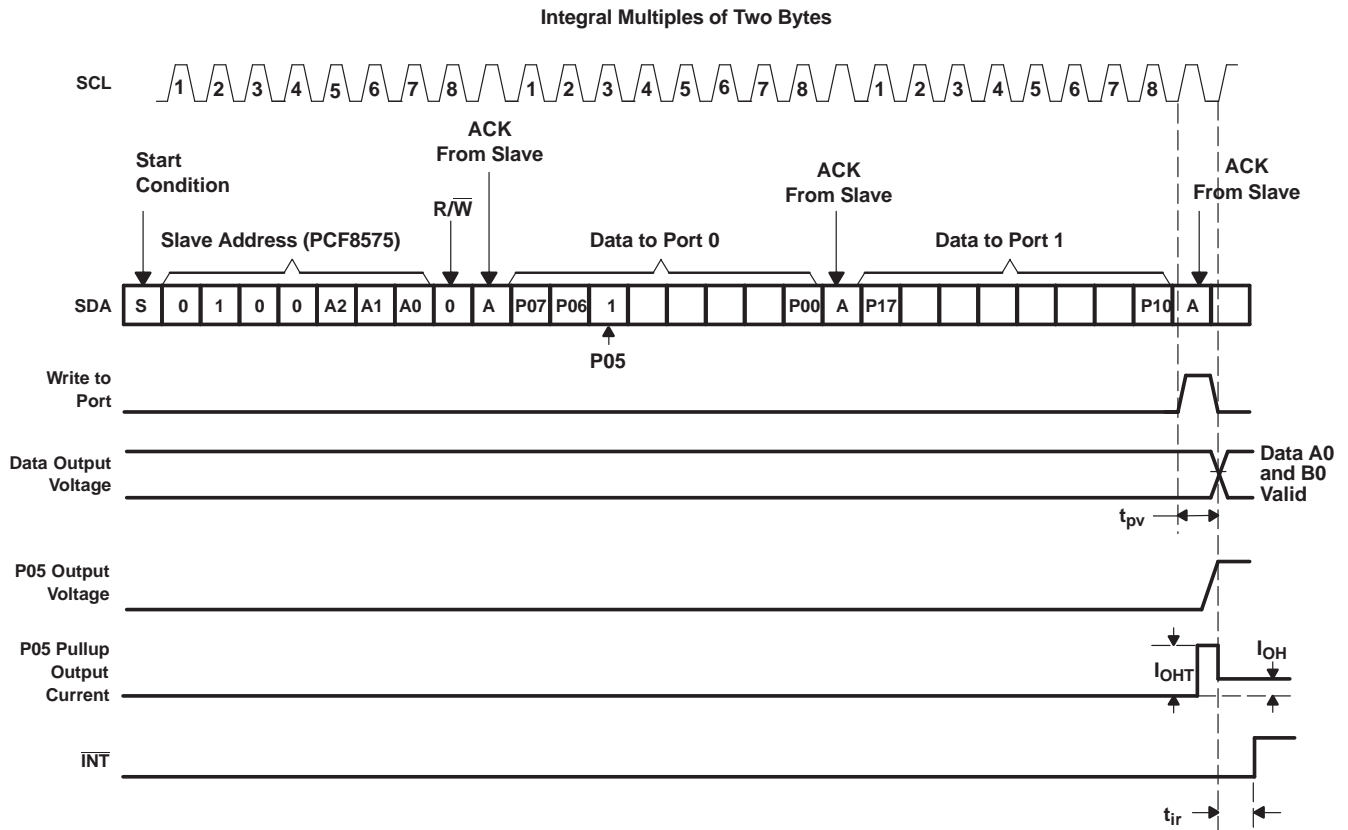
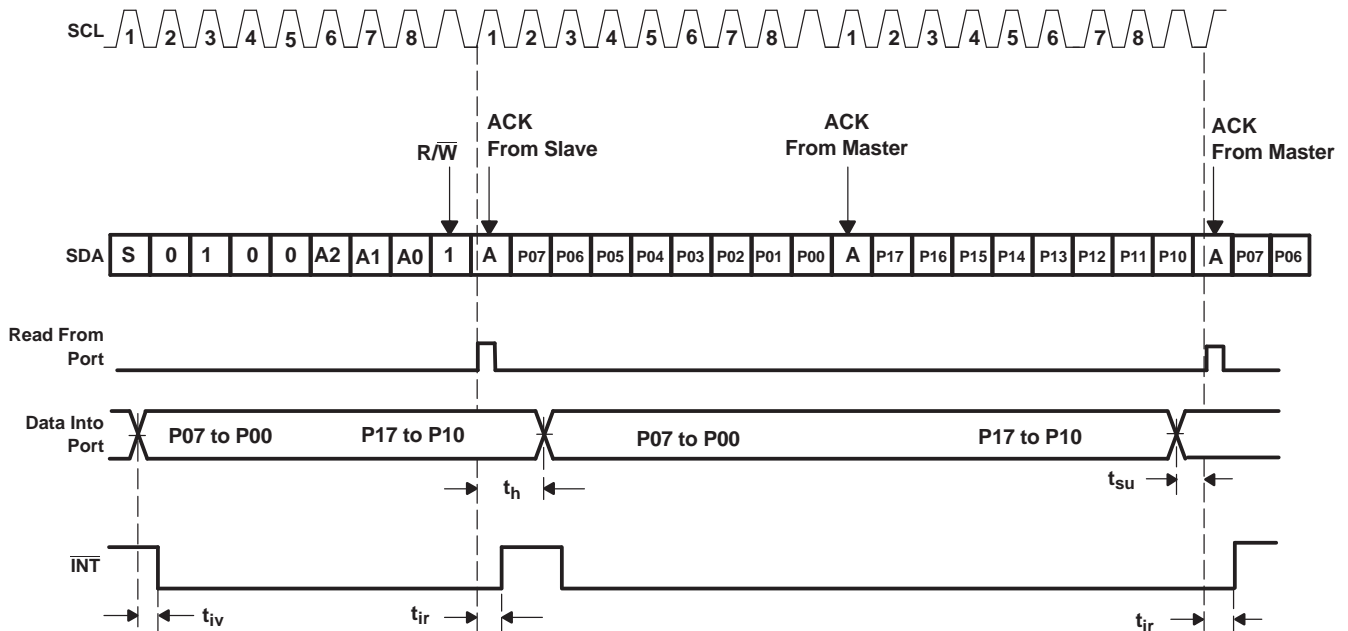

Figure 4. Write Mode (Output)



A low-to-high transition of SDA while SCL is high is defined as the stop condition (P). The transfer of data can be stopped at any moment by a stop condition. When this occurs, data present at the latest ACK phase is valid (output mode). Input data is lost.

Figure 5. Read Mode (Input)

# PCF8575

## REMOTE 16-BIT I<sup>2</sup>C AND SMBus I/O EXPANDER WITH INTERRUPT OUTPUT

SCPS121D–JANUARY 2005–REVISED APRIL 2007

### Address Reference

INPUTS			I <sup>2</sup> C BUS SLAVE ADDRESS
A2	A1	A0	
L	L	L	32 (decimal), 20 (hexadecimal)
L	L	H	33 (decimal), 21 (hexadecimal)
L	H	L	34 (decimal), 22 (hexadecimal)
L	H	H	35 (decimal), 23 (hexadecimal)
H	L	L	36 (decimal), 24 (hexadecimal)
H	L	H	37 (decimal), 25 (hexadecimal)
H	H	L	38 (decimal), 26 (hexadecimal)
H	H	H	39 (decimal), 27 (hexadecimal)

### Absolute Maximum Ratings<sup>(1)</sup>

over operating free-air temperature range (unless otherwise noted)

		MIN	MAX	UNIT
V <sub>CC</sub>	Supply voltage range	–0.5	6.5	V
V <sub>I</sub>	Input voltage range <sup>(2)</sup>	–0.5	V <sub>CC</sub> + 0.5	V
V <sub>O</sub>	Output voltage range <sup>(2)</sup>	–0.5	V <sub>CC</sub> + 0.5	V
I <sub>IK</sub>	Input clamp current	V <sub>I</sub> < 0	–20	mA
I <sub>OK</sub>	Output clamp current	V <sub>O</sub> < 0	–20	mA
I <sub>OK</sub>	Input/output clamp current	V <sub>O</sub> < 0 or V <sub>O</sub> > V <sub>CC</sub>	–20	mA
I <sub>OL</sub>	Continuous output low current	V <sub>O</sub> = 0 to V <sub>CC</sub>	50	mA
I <sub>OH</sub>	Continuous output high current	V <sub>O</sub> = 0 to V <sub>CC</sub>	–4	mA
	Continuous current through V <sub>CC</sub> or GND		±100	mA
θ <sub>JA</sub>	Package thermal impedance <sup>(3)</sup>	DB package	63	°C/W
		DBQ package	61	
		DGV package	86	
		DW package	46	
		PW package	88	
		RGE package	53	
T <sub>stg</sub>	Storage temperature range	–65	150	°C

(1) Stresses beyond those listed under "absolute maximum ratings" may cause permanent damage to the device. These are stress ratings only, and functional operation of the device at these or any other conditions beyond those indicated under "recommended operating conditions" is not implied. Exposure to absolute-maximum-rated conditions for extended periods may affect device reliability.

(2) The input negative-voltage and output voltage ratings may be exceeded if the input and output current ratings are observed.

(3) The package thermal impedance is calculated in accordance with JESD 51-7.

### Recommended Operating Conditions

		MIN	MAX	UNIT
V <sub>CC</sub>	Supply voltage	2.5	5.5	V
V <sub>IH</sub>	High-level input voltage	0.7 × V <sub>CC</sub>	V <sub>CC</sub> + 0.5	V
V <sub>IL</sub>	Low-level input voltage	–0.5	0.3 × V <sub>CC</sub>	V
I <sub>OH</sub>	P-port high-level output current		–1	mA
I <sub>OHT</sub>	P-port transient pullup current		–10	mA
I <sub>OL</sub>	P-port low-level output current		25	mA
T <sub>A</sub>	Operating free-air temperature	–40	85	°C

## Electrical Characteristics

over recommended operating free-air temperature range (unless otherwise noted)

PARAMETER		TEST CONDITIONS	V <sub>CC</sub>	MIN	TYP <sup>(1)</sup>	MAX	UNIT
V <sub>IK</sub>	Input diode clamp voltage	I <sub>I</sub> = -18 mA	2.5 V to 5.5 V	-1.2			V
V <sub>POR</sub>	Power-on reset voltage <sup>(2)</sup>	V <sub>I</sub> = V <sub>CC</sub> or GND, I <sub>O</sub> = 0	V <sub>POR</sub>		1.2	1.8	V
I <sub>OH</sub>	P port	V <sub>O</sub> = GND	2.5 V to 5.5 V	-30		-300	μA
I <sub>OHT</sub>	P-port transient pullup current	High during ACK, V <sub>OH</sub> = GND	2.5 V	-0.5	-1		mA
I <sub>OL</sub>	SDA	V <sub>OL</sub> = 0.4 V	2.5 V to 5.5 V	3			mA
	P port	V <sub>OL</sub> = 0.4 V		5		15	
		V <sub>OL</sub> = 1 V		10		25	
	INT	V <sub>OL</sub> = 0.4 V		1.6			
I <sub>I</sub>	SCL, SDA	V <sub>I</sub> = V <sub>CC</sub> or GND	2.5 V to 5.5 V			±5	μA
	A0, A1, A2					±1	
I <sub>IHL</sub>	P port	V <sub>I</sub> ≥ V <sub>CC</sub> or V <sub>I</sub> ≤ GND	2.5 V to 5.5 V			±400	μA
I <sub>CC</sub>	Operating mode	V <sub>I</sub> = V <sub>CC</sub> or GND, I <sub>O</sub> = 0, f <sub>scl</sub> = 400 kHz	5.5 V	100		200	μA
			3.6 V	30		75	
			2.7 V	20		50	
	Standby mode	V <sub>I</sub> = V <sub>CC</sub> or GND, I <sub>O</sub> = 0, f <sub>scl</sub> = 0 kHz	5.5 V	2.5		10	
			3.6 V	2.5		10	
			2.7 V	2.5		10	
ΔI <sub>CC</sub>	Supply current increase	One input at V <sub>CC</sub> - 0.6 V, Other inputs at V <sub>CC</sub> or GND	2.5 V to 5.5 V			200	μA
C <sub>I</sub>	SCL	V <sub>I</sub> = V <sub>CC</sub> or GND	2.5 V to 5.5 V	3		7	pF
C <sub>io</sub>	SDA	V <sub>IO</sub> = V <sub>CC</sub> or GND	2.5 V to 5.5 V	3		7	pF
	P port			4		10	

(1) All typical values are at nominal supply voltage (2.5-V, 3.3-V, or 5-V V<sub>CC</sub>) and T<sub>A</sub> = 25°C.

(2) The power-on reset circuit resets the I<sup>2</sup>C bus logic with V<sub>CC</sub> < V<sub>POR</sub> and sets all I/Os to logic high (with current source to V<sub>CC</sub>).

## I<sup>2</sup>C Interface Timing Requirements

over recommended operating free-air temperature range (unless otherwise noted) (see [Figure 6](#))

		MIN	MAX	UNIT
f <sub>scl</sub>	I <sup>2</sup> C clock frequency		400	kHz
t <sub>sch</sub>	I <sup>2</sup> C clock high time	0.6		μs
t <sub>scl</sub>	I <sup>2</sup> C clock low time	1.3		μs
t <sub>sp</sub>	I <sup>2</sup> C spike time		50	ns
t <sub>sds</sub>	I <sup>2</sup> C serial data setup time	100		ns
t <sub>sdh</sub>	I <sup>2</sup> C serial data hold time	0		ns
t <sub>icr</sub>	I <sup>2</sup> C input rise time	20 + 0.1C <sub>b</sub> <sup>(1)</sup>	300	ns
t <sub>icf</sub>	I <sup>2</sup> C input fall time	20 + 0.1C <sub>b</sub> <sup>(1)</sup>	300	ns
t <sub>ocf</sub>	I <sup>2</sup> C output fall time	10-pF to 400-pF bus	300	ns
t <sub>buf</sub>	I <sup>2</sup> C bus free time between Stop and Start	1.3		μs
t <sub>sts</sub>	I <sup>2</sup> C start or repeated Start condition setup	0.6		μs
t <sub>sth</sub>	I <sup>2</sup> C start or repeated Start condition hold	0.6		μs
t <sub>sps</sub>	I <sup>2</sup> C Stop condition setup	0.6		μs
t <sub>vd</sub>	Valid-data time	SCL low to SDA output valid	1.2	μs
C <sub>b</sub>	I <sup>2</sup> C bus capacitive load		400	pF

(1) C<sub>b</sub> = total bus capacitance of one bus line in pF

# PCF8575 REMOTE 16-BIT I<sup>2</sup>C AND SMBus I/O EXPANDER WITH INTERRUPT OUTPUT

SCPS121D–JANUARY 2005–REVISED APRIL 2007

## Switching Characteristics

over recommended operating free-air temperature range,  $C_L \leq 100$  pF (unless otherwise noted) (see [Figure 7](#) and [Figure 8](#))

PARAMETER		FROM (INPUT)	TO (OUTPUT)	MIN	MAX	UNIT
$t_{iv}$	Interrupt valid time	P port	$\overline{INT}$		4	$\mu$ s
$t_{ir}$	Interrupt reset delay time	SCL	$\overline{INT}$		4	$\mu$ s
$t_{pv}$	Output data valid	SCL	P port		4	$\mu$ s
$t_{su}$	Input data setup time	P port	SCL	0		$\mu$ s
$t_h$	Input data hold time	P port	SCL	4		$\mu$ s

TYPICAL OPERATING CHARACTERISTICS

T<sub>A</sub> = 25°C (unless otherwise noted)

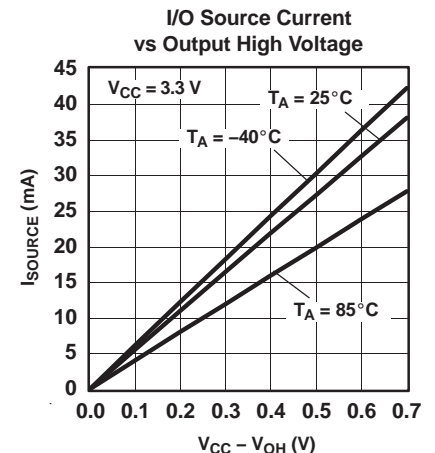
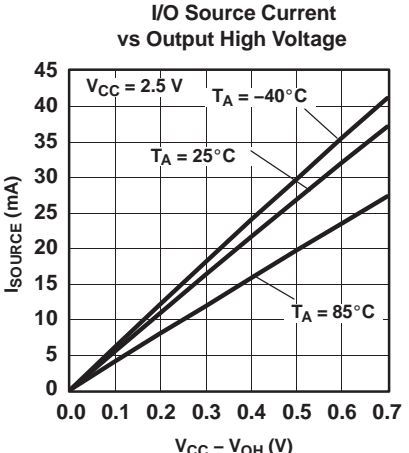
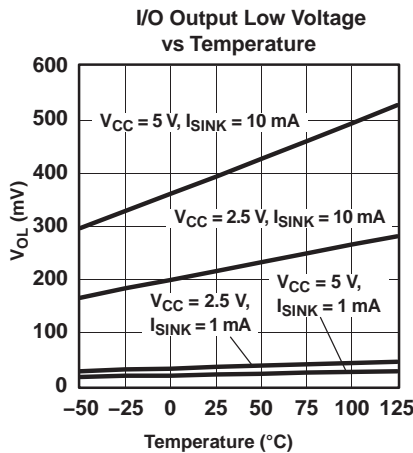
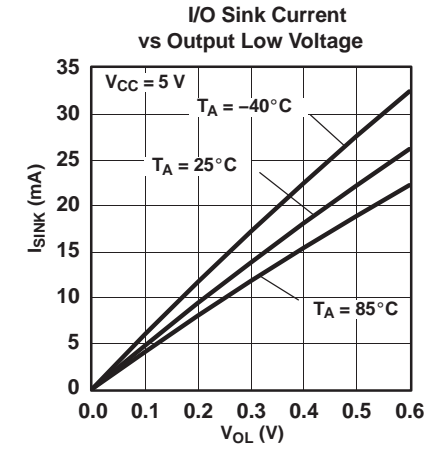
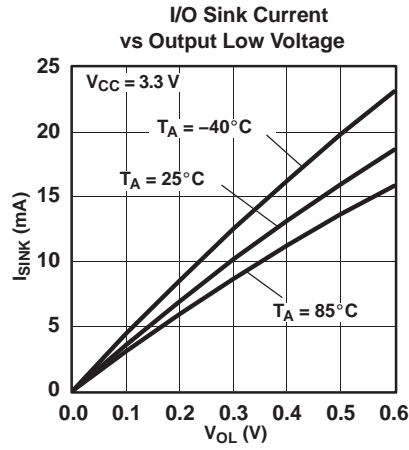
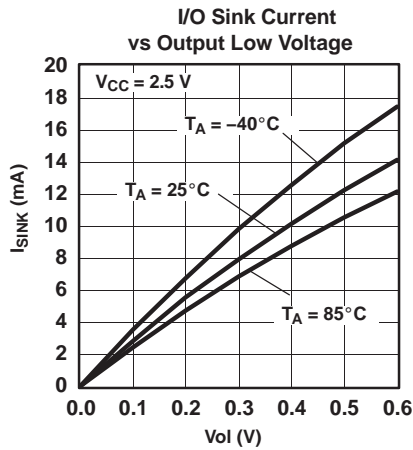
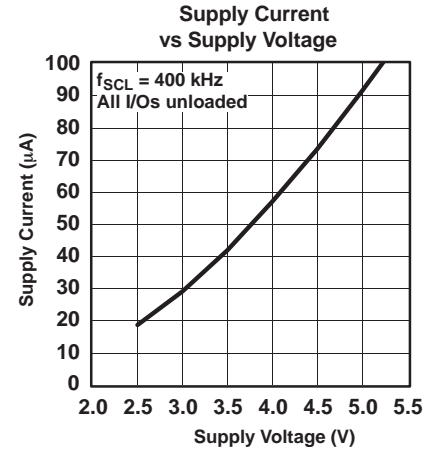
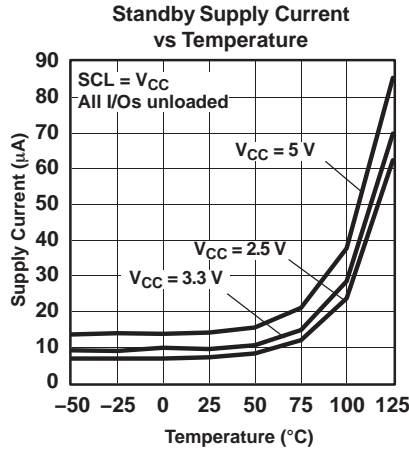
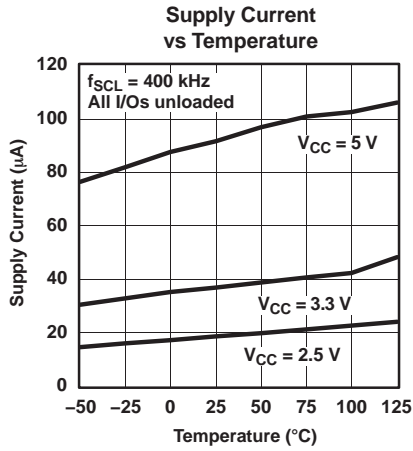

# PCF8575 REMOTE 16-BIT I<sup>2</sup>C AND SMBus I/O EXPANDER WITH INTERRUPT OUTPUT

SCPS121D–JANUARY 2005–REVISED APRIL 2007

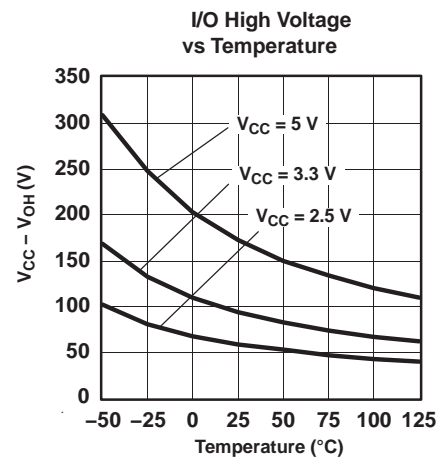
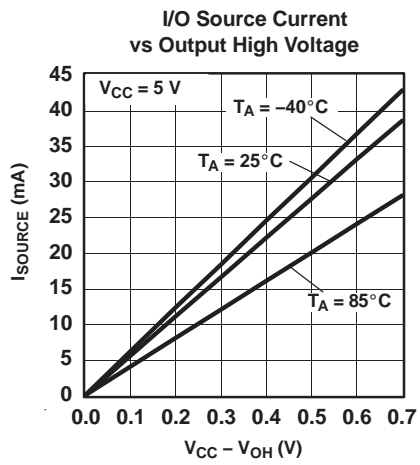



PARAMETER MEASUREMENT INFORMATION (continued)

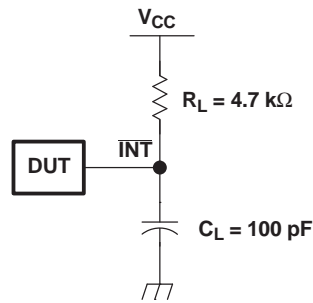

INTERRUPT LOAD CONFIGURATION

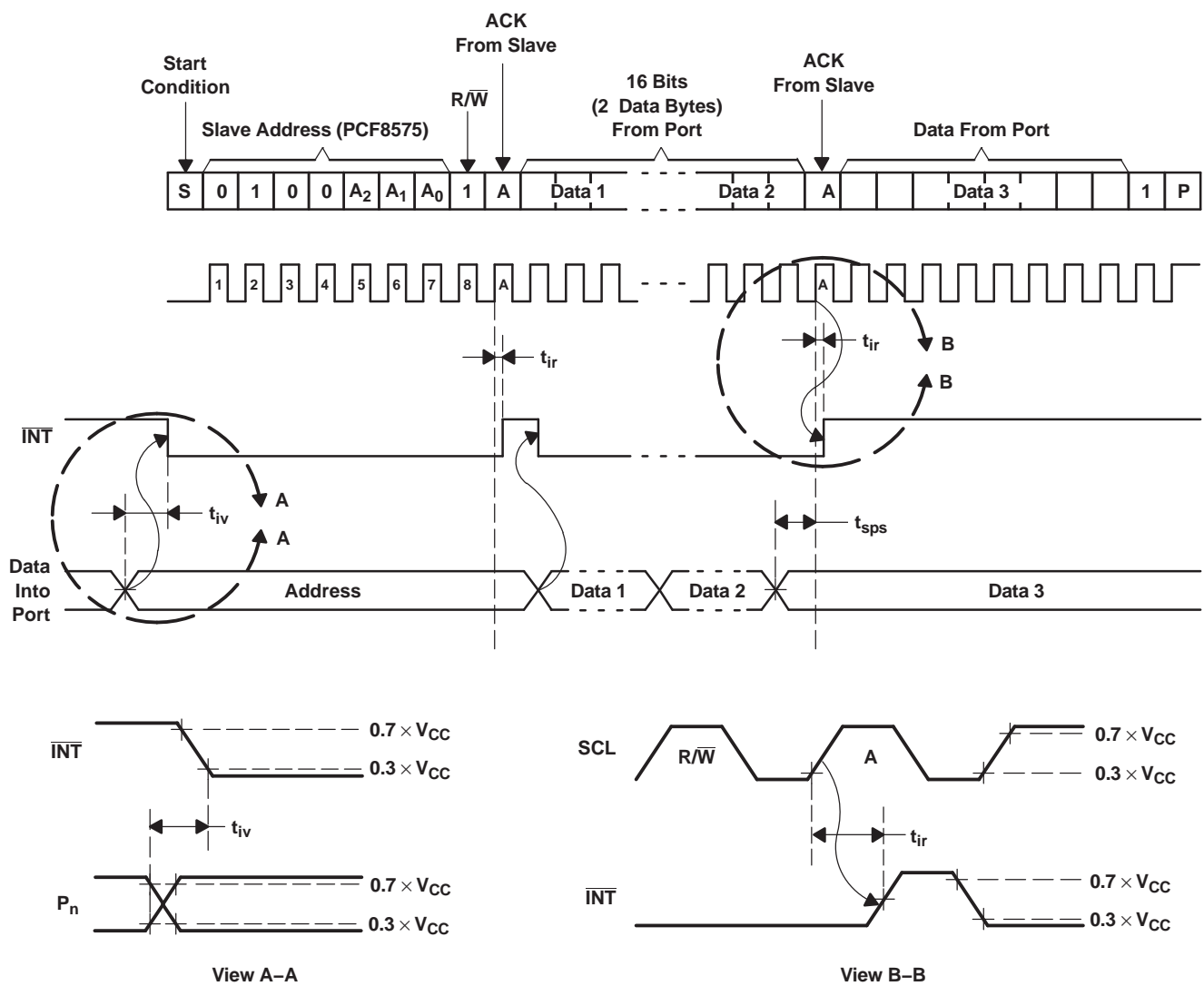
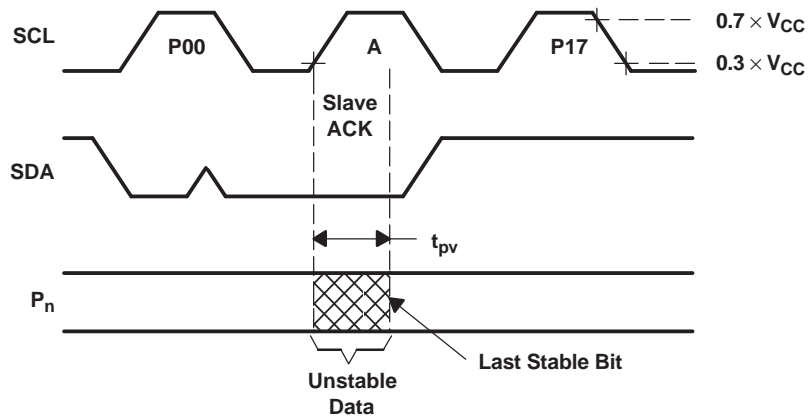
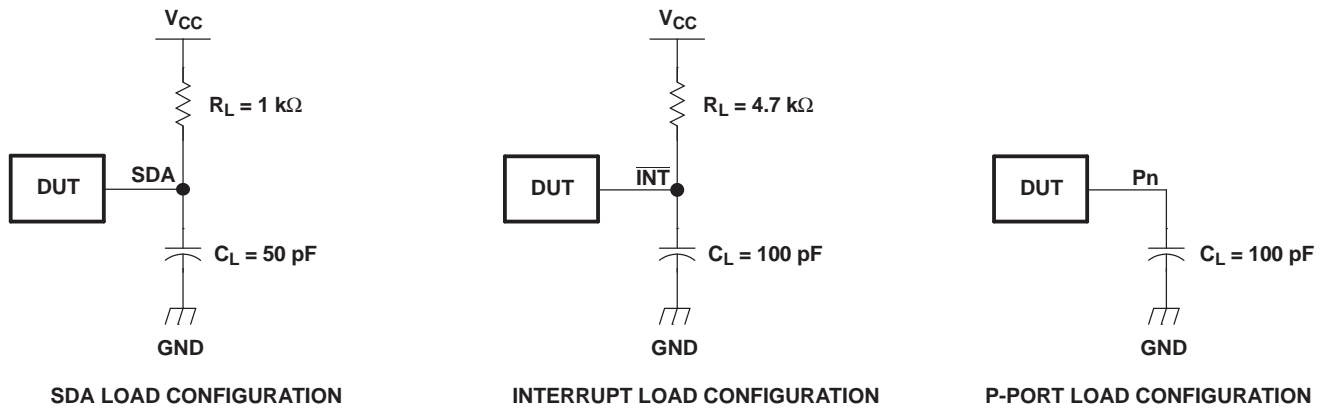
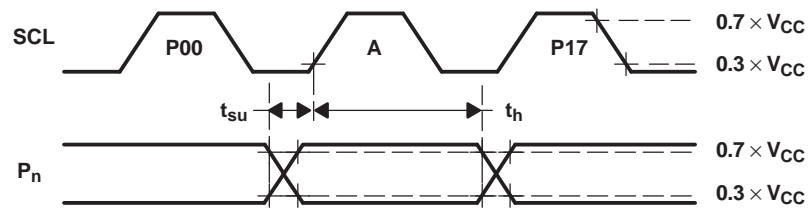

Figure 7. Interrupt Load Circuit and Voltage Waveforms

PARAMETER MEASUREMENT INFORMATION (continued)



Write-Mode Timing ( $R/\bar{W} = 0$ )



Read-Mode Timing ( $R/\bar{W} = 1$ )

Figure 8. P-Port Load Circuits and Voltage Waveforms

**THERMAL PAD MECHANICAL DATA**  
**RGE (S-PQFP-N24)**

THERMAL INFORMATION

This package incorporates an exposed thermal pad that is designed to be attached directly to an external heatsink. The thermal pad must be soldered directly to the printed circuit board (PCB), the PCB can be used as a heatsink. In addition, through the use of thermal vias, the thermal pad can be attached directly to a ground plane or special heatsink structure designed into the PCB. This design optimizes the heat transfer from the integrated circuit (IC).

For information on the Quad Flatpack No-Lead (QFN) package and its advantages, refer to Application Report, Quad Flatpack No-Lead Logic Packages, Texas Instruments Literature No. SCBA017. This document is available at [www.ti.com](http://www.ti.com).

The exposed thermal pad dimensions for this package are shown in the following illustration.

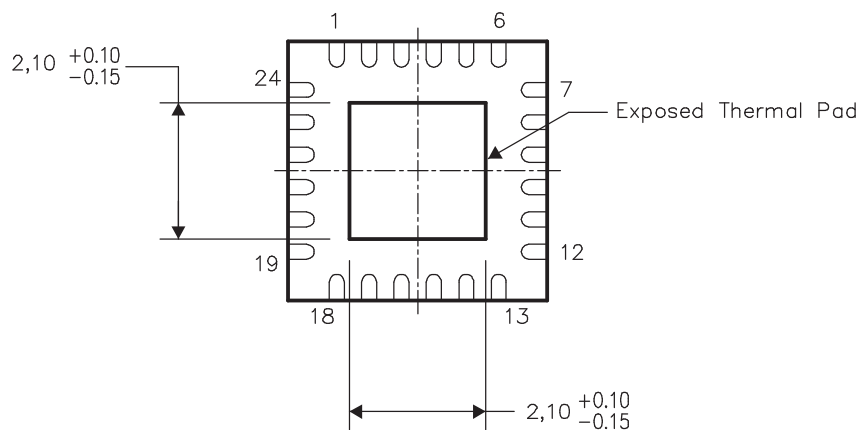

Bottom View

NOTE: All linear dimensions are in millimeters

Exposed Thermal Pad Dimensions

**PACKAGING INFORMATION**

Orderable Device	Status <sup>(1)</sup>	Package Type	Package Drawing	Pins	Package Qty	Eco Plan <sup>(2)</sup>	Lead/Ball Finish	MSL Peak Temp <sup>(3)</sup>
PCF8575DBQR	ACTIVE	SSOP/QSOP	DBQ	24	2500	Green (RoHS & no Sb/Br)	CU NIPDAU	Level-2-260C-1 YEAR
PCF8575DBQRE4	ACTIVE	SSOP/QSOP	DBQ	24	2500	Green (RoHS & no Sb/Br)	CU NIPDAU	Level-2-260C-1 YEAR
PCF8575DBQRG4	ACTIVE	SSOP/QSOP	DBQ	24	2500	Green (RoHS & no Sb/Br)	CU NIPDAU	Level-2-260C-1 YEAR
PCF8575DBR	ACTIVE	SSOP	DB	24	2000	Green (RoHS & no Sb/Br)	CU NIPDAU	Level-1-260C-UNLIM
PCF8575DBRE4	ACTIVE	SSOP	DB	24	2000	Green (RoHS & no Sb/Br)	CU NIPDAU	Level-1-260C-UNLIM
PCF8575DBRG4	ACTIVE	SSOP	DB	24	2000	Green (RoHS & no Sb/Br)	CU NIPDAU	Level-1-260C-UNLIM
PCF8575DGVR	ACTIVE	TVSOP	DGV	24	2000	Green (RoHS & no Sb/Br)	CU NIPDAU	Level-1-260C-UNLIM
PCF8575DGVRE4	ACTIVE	TVSOP	DGV	24	2000	Green (RoHS & no Sb/Br)	CU NIPDAU	Level-1-260C-UNLIM
PCF8575DGVRG4	ACTIVE	TVSOP	DGV	24	2000	Green (RoHS & no Sb/Br)	CU NIPDAU	Level-1-260C-UNLIM
PCF8575DW	ACTIVE	SOIC	DW	24	25	Green (RoHS & no Sb/Br)	CU NIPDAU	Level-1-260C-UNLIM
PCF8575DWG4	ACTIVE	SOIC	DW	24	25	Green (RoHS & no Sb/Br)	CU NIPDAU	Level-1-260C-UNLIM
PCF8575DWR	ACTIVE	SOIC	DW	24	2000	Green (RoHS & no Sb/Br)	CU NIPDAU	Level-1-260C-UNLIM
PCF8575DWRG4	ACTIVE	SOIC	DW	24	2000	Green (RoHS & no Sb/Br)	CU NIPDAU	Level-1-260C-UNLIM
PCF8575PW	ACTIVE	TSSOP	PW	24	60	Green (RoHS & no Sb/Br)	CU NIPDAU	Level-1-260C-UNLIM
PCF8575PWE4	ACTIVE	TSSOP	PW	24	60	Green (RoHS & no Sb/Br)	CU NIPDAU	Level-1-260C-UNLIM
PCF8575PWG4	ACTIVE	TSSOP	PW	24	60	Green (RoHS & no Sb/Br)	CU NIPDAU	Level-1-260C-UNLIM
PCF8575PWR	ACTIVE	TSSOP	PW	24	2000	Green (RoHS & no Sb/Br)	CU NIPDAU	Level-1-260C-UNLIM
PCF8575PWRE4	ACTIVE	TSSOP	PW	24	2000	Green (RoHS & no Sb/Br)	CU NIPDAU	Level-1-260C-UNLIM
PCF8575PWRG4	ACTIVE	TSSOP	PW	24	2000	Green (RoHS & no Sb/Br)	CU NIPDAU	Level-1-260C-UNLIM
PCF8575RGER	ACTIVE	VQFN	RGE	24	3000	Green (RoHS & no Sb/Br)	CU NIPDAU	Level-2-260C-1 YEAR
PCF8575RGERG4	ACTIVE	VQFN	RGE	24	3000	Green (RoHS & no Sb/Br)	CU NIPDAU	Level-2-260C-1 YEAR

<sup>(1)</sup> The marketing status values are defined as follows:

**ACTIVE:** Product device recommended for new designs.

**LIFEBUY:** TI has announced that the device will be discontinued, and a lifetime-buy period is in effect.

**NRND:** Not recommended for new designs. Device is in production to support existing customers, but TI does not recommend using this part in a new design.

**PREVIEW:** Device has been announced but is not in production. Samples may or may not be available.

**OBSELETE:** TI has discontinued the production of the device.

---

(2) Eco Plan - The planned eco-friendly classification: Pb-Free (RoHS), Pb-Free (RoHS Exempt), or Green (RoHS & no Sb/Br) - please check <http://www.ti.com/productcontent> for the latest availability information and additional product content details.

**TBD:** The Pb-Free/Green conversion plan has not been defined.

**Pb-Free (RoHS):** TI's terms "Lead-Free" or "Pb-Free" mean semiconductor products that are compatible with the current RoHS requirements for all 6 substances, including the requirement that lead not exceed 0.1% by weight in homogeneous materials. Where designed to be soldered at high temperatures, TI Pb-Free products are suitable for use in specified lead-free processes.

**Pb-Free (RoHS Exempt):** This component has a RoHS exemption for either 1) lead-based flip-chip solder bumps used between the die and package, or 2) lead-based die adhesive used between the die and leadframe. The component is otherwise considered Pb-Free (RoHS compatible) as defined above.

**Green (RoHS & no Sb/Br):** TI defines "Green" to mean Pb-Free (RoHS compatible), and free of Bromine (Br) and Antimony (Sb) based flame retardants (Br or Sb do not exceed 0.1% by weight in homogeneous material)

(3) MSL, Peak Temp. -- The Moisture Sensitivity Level rating according to the JEDEC industry standard classifications, and peak solder temperature.

**Important Information and Disclaimer:**The information provided on this page represents TI's knowledge and belief as of the date that it is provided. TI bases its knowledge and belief on information provided by third parties, and makes no representation or warranty as to the accuracy of such information. Efforts are underway to better integrate information from third parties. TI has taken and continues to take reasonable steps to provide representative and accurate information but may not have conducted destructive testing or chemical analysis on incoming materials and chemicals. TI and TI suppliers consider certain information to be proprietary, and thus CAS numbers and other limited information may not be available for release.

In no event shall TI's liability arising out of such information exceed the total purchase price of the TI part(s) at issue in this document sold by TI to Customer on an annual basis.

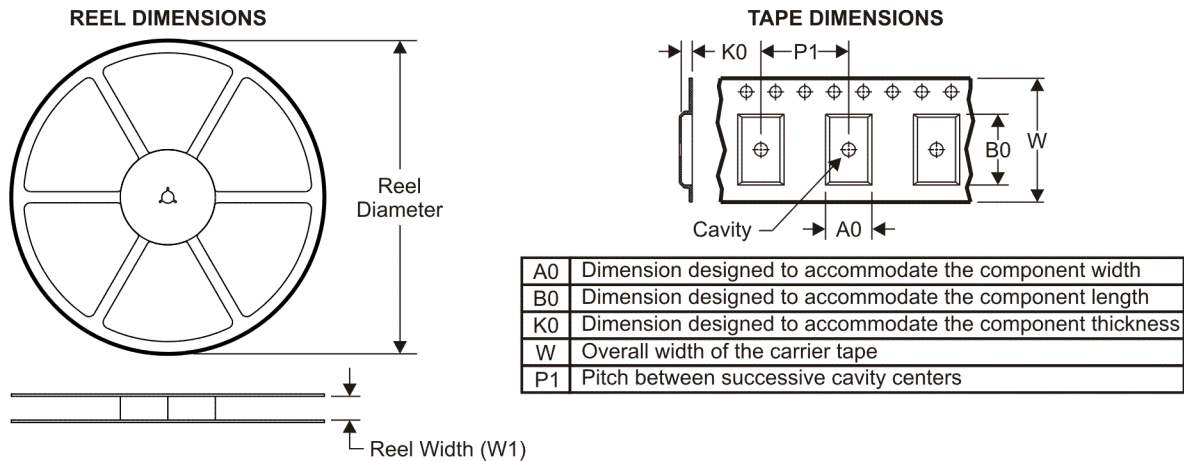
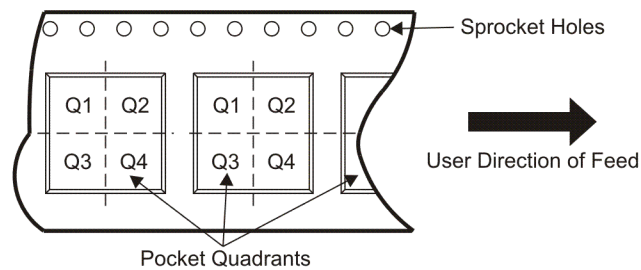
**TAPE AND REEL INFORMATION**

**QUADRANT ASSIGNMENTS FOR PIN 1 ORIENTATION IN TAPE**

\*All dimensions are nominal

Device	Package Type	Package Drawing	Pins	SPQ	Reel Diameter (mm)	Reel Width W1 (mm)	A0 (mm)	B0 (mm)	K0 (mm)	P1 (mm)	W (mm)	Pin1 Quadrant
PCF8575DBQR	SSOP/QSOP	DBQ	24	2500	330.0	16.4	6.5	9.0	2.1	8.0	16.0	Q1
PCF8575DBR	SSOP	DB	24	2000	330.0	16.4	8.2	8.8	2.5	12.0	16.0	Q1
PCF8575DGVR	TVSOP	DGV	24	2000	330.0	12.4	6.9	5.6	1.6	8.0	12.0	Q1
PCF8575DWR	SOIC	DW	24	2000	330.0	24.4	10.75	15.7	2.7	12.0	24.0	Q1
PCF8575PWR	TSSOP	PW	24	2000	330.0	16.4	6.95	8.3	1.6	8.0	16.0	Q1
PCF8575RGER	VQFN	RGE	24	3000	330.0	12.4	4.25	4.25	1.15	8.0	12.0	Q2

**TAPE AND REEL BOX DIMENSIONS**

\*All dimensions are nominal

Device	Package Type	Package Drawing	Pins	SPQ	Length (mm)	Width (mm)	Height (mm)
PCF8575DBQR	SSOP/QSOP	DBQ	24	2500	346.0	346.0	33.0
PCF8575DBR	SSOP	DB	24	2000	346.0	346.0	33.0
PCF8575DGVR	TVSOP	DGV	24	2000	346.0	346.0	29.0
PCF8575DWR	SOIC	DW	24	2000	346.0	346.0	41.0
PCF8575PWR	TSSOP	PW	24	2000	346.0	346.0	33.0
PCF8575RGER	VQFN	RGE	24	3000	346.0	346.0	29.0

DGV (R-PDSO-G\*\*)

PLASTIC SMALL-OUTLINE

24 PINS SHOWN



- NOTES: A. All linear dimensions are in millimeters.  
 B. This drawing is subject to change without notice.  
 C. Body dimensions do not include mold flash or protrusion, not to exceed 0,15 per side.  
 D. Falls within JEDEC: 24/48 Pins – MO-153  
 14/16/20/56 Pins – MO-194

DW (R-PDSO-G24)

PLASTIC SMALL OUTLINE

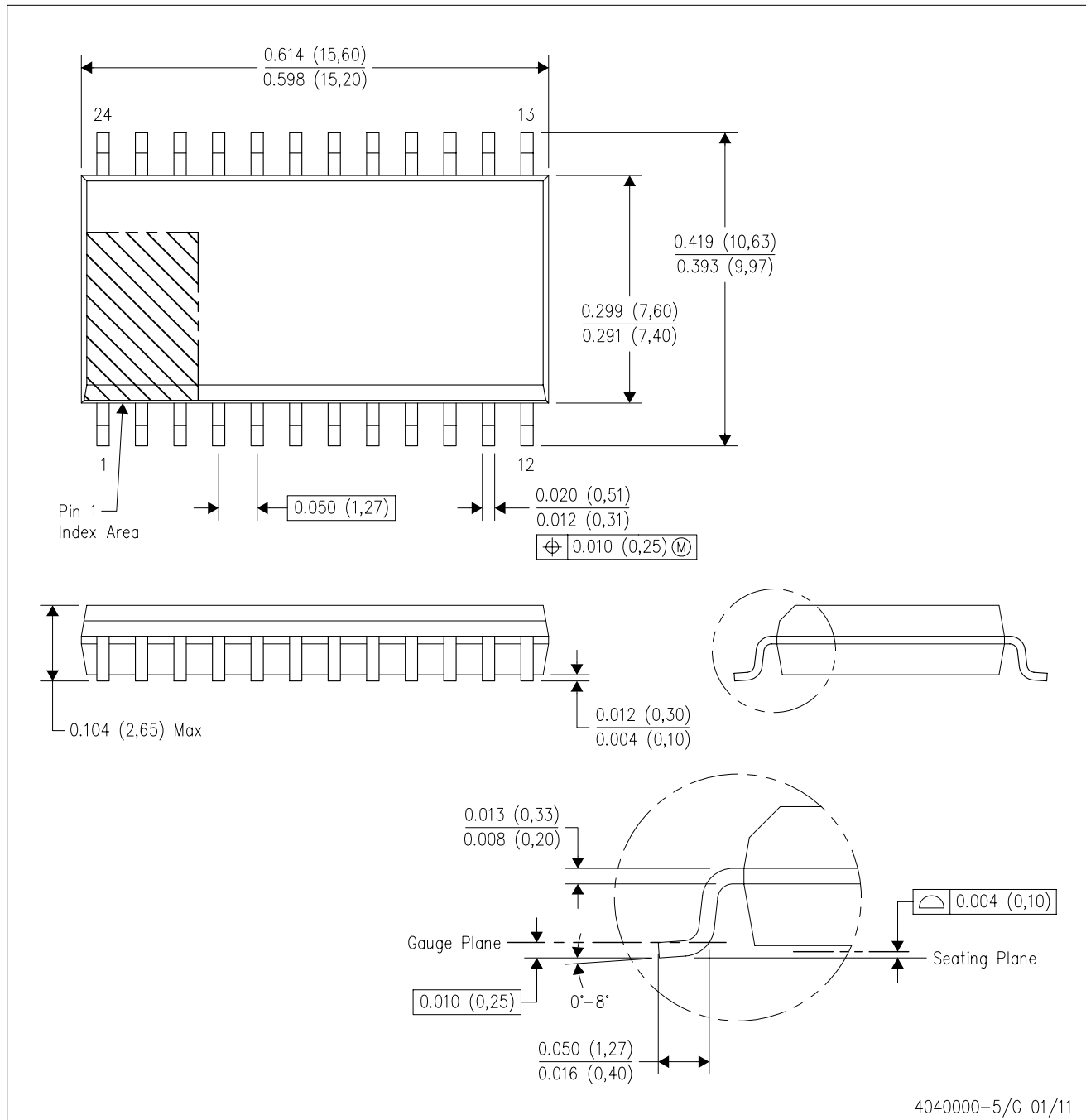

- NOTES:
- A. All linear dimensions are in inches (millimeters). Dimensioning and tolerancing per ASME Y14.5M-1994.
  - B. This drawing is subject to change without notice.
  - C. Body dimensions do not include mold flash or protrusion not to exceed 0.006 (0,15).
  - D. Falls within JEDEC MS-013 variation AD.

DBQ (R-PDSO-G24)

PLASTIC SMALL-OUTLINE PACKAGE

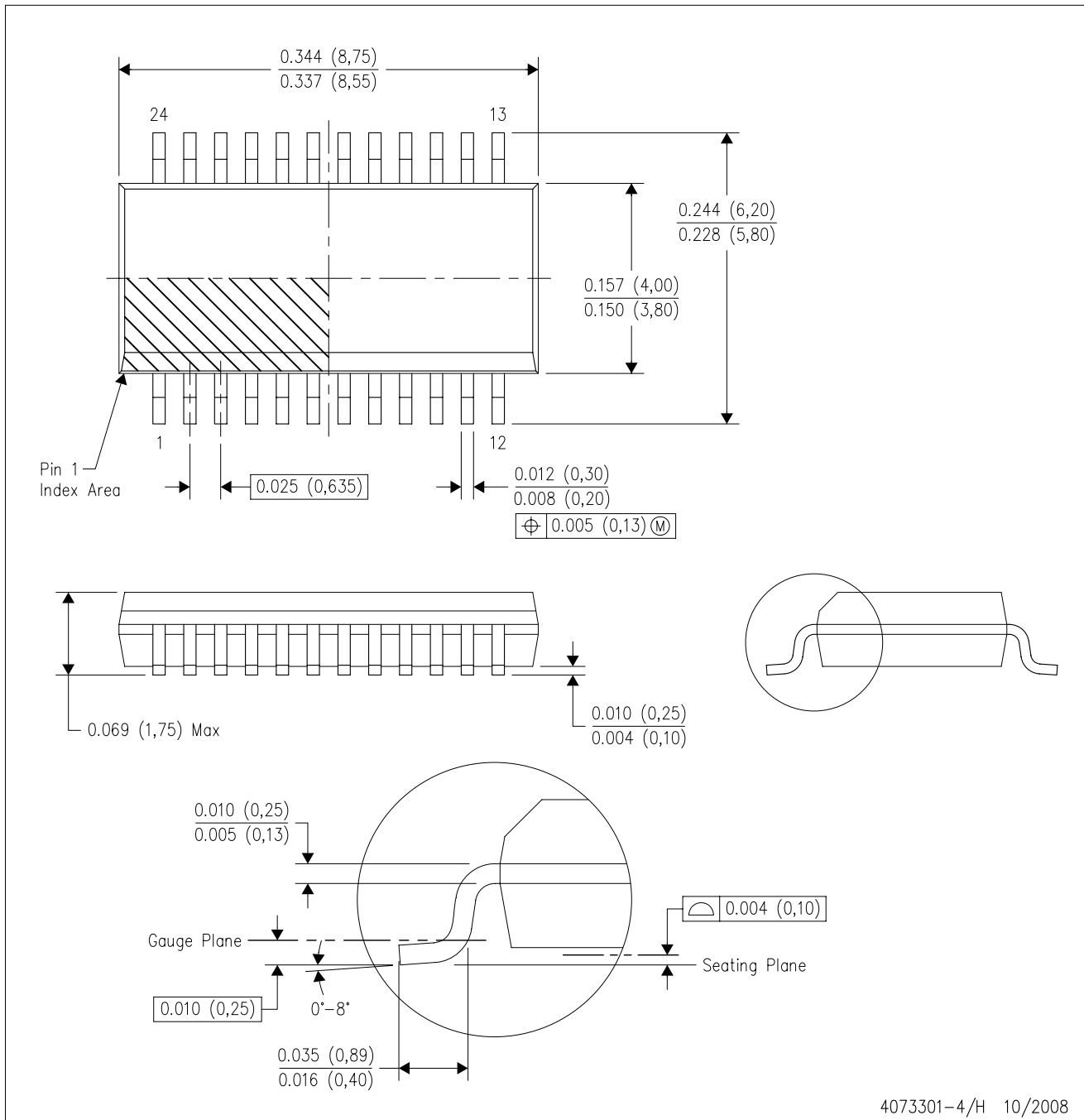

- NOTES:
- A. All linear dimensions are in inches (millimeters).
  - B. This drawing is subject to change without notice.
  - C. Body dimensions do not include mold flash or protrusion not to exceed 0.006 (0,15) per side.
  - D. Falls within JEDEC MO-137 variation AE.

DBQ (R-PDSO-G24)

PLASTIC SMALL OUTLINE PACKAGE

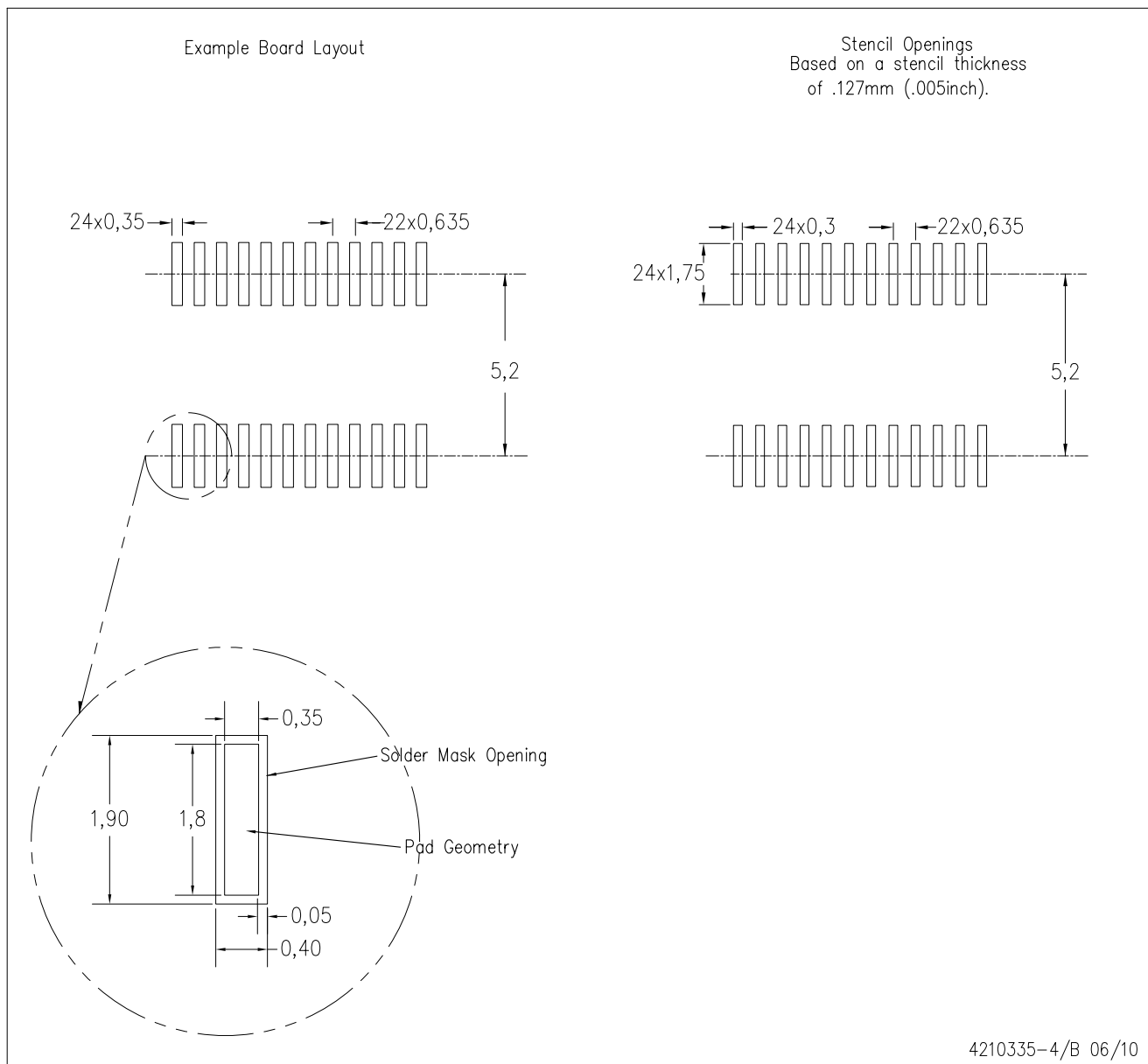

- NOTES:
- A. All linear dimensions are in millimeters.
  - B. This drawing is subject to change without notice.
  - C. Customers should place a note on the circuit board fabrication drawing not to alter the center solder mask defined pad.
  - D. Publication IPC-7351 is recommended for alternate designs.
  - E. Laser cutting apertures with trapezoidal walls and also rounding corners will offer better paste release. Customers should contact their board assembly site for stencil design recommendations. Example stencil design based on a 50% volumetric metal load solder paste. Refer to IPC-7525 for other stencil recommendations.

PW (R-PDSO-G24)

PLASTIC SMALL OUTLINE

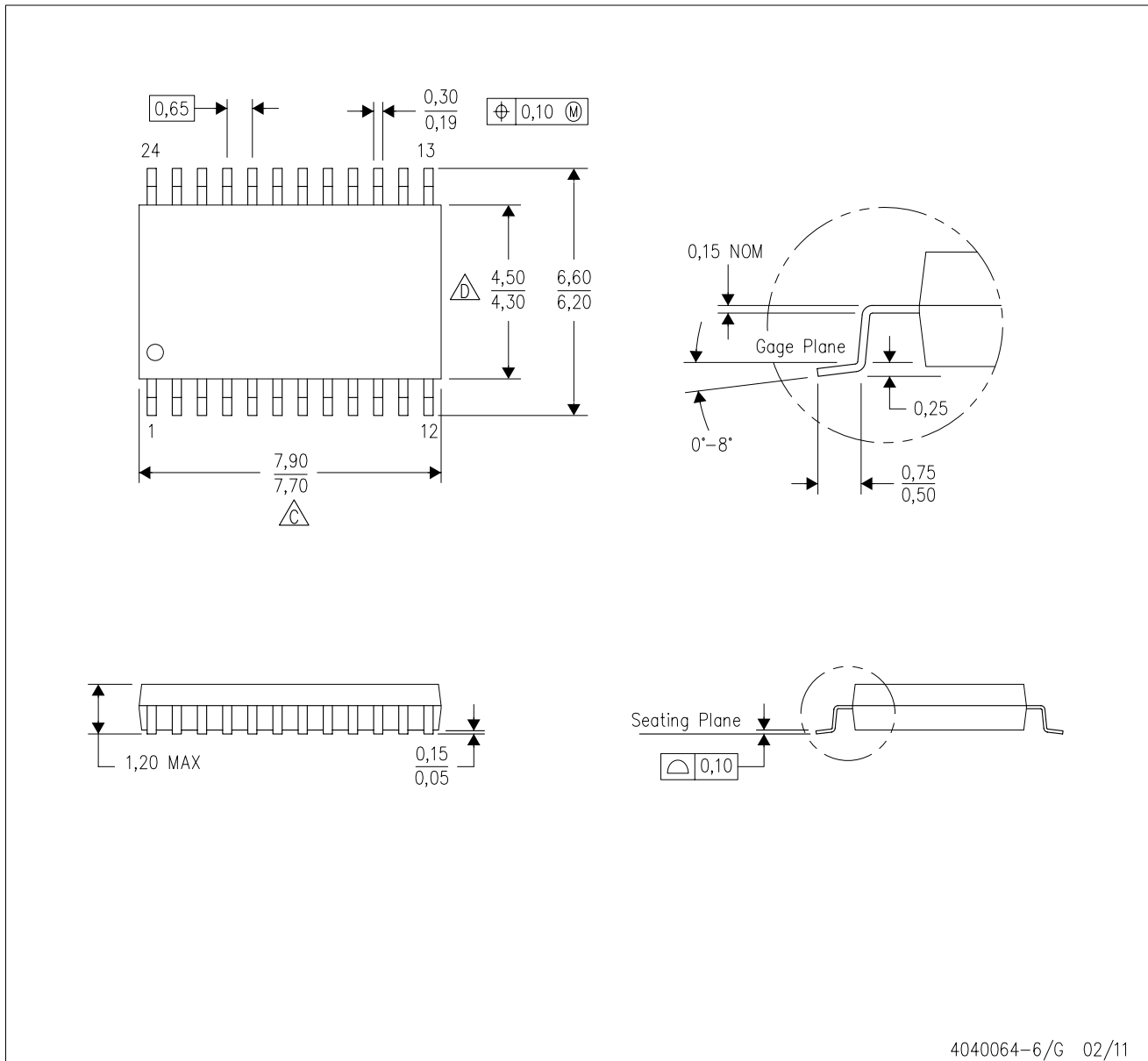

4040064-6/G 02/11

- NOTES:
- A. All linear dimensions are in millimeters. Dimensioning and tolerancing per ASME Y14.5M-1994.
  - B. This drawing is subject to change without notice.
  - C. Body length does not include mold flash, protrusions, or gate burrs. Mold flash, protrusions, or gate burrs shall not exceed 0,15 each side.
  - D. Body width does not include interlead flash. Interlead flash shall not exceed 0,25 each side.
  - E. Falls within JEDEC MO-153

PW (R-PDSO-G24)

PLASTIC SMALL OUTLINE

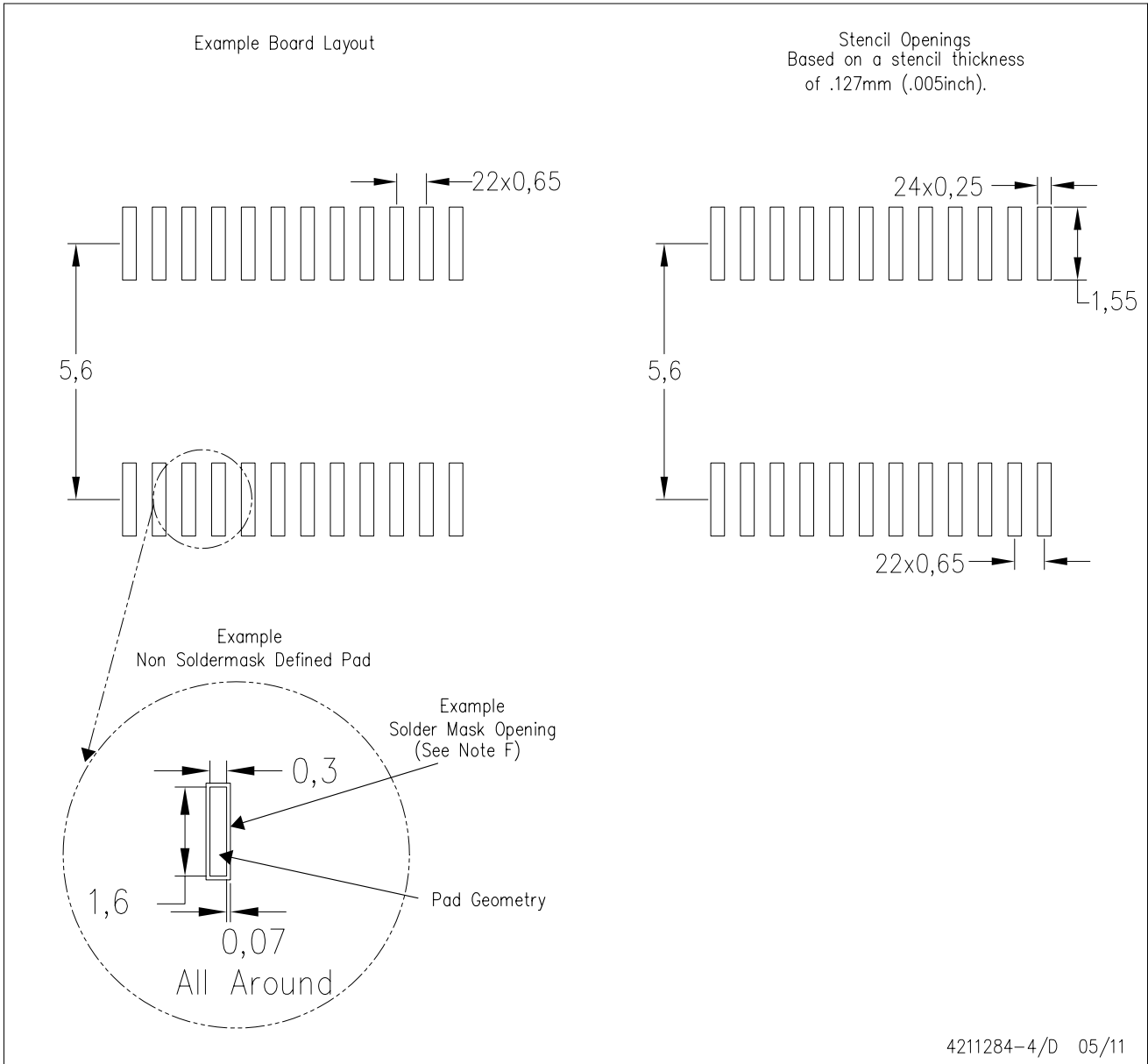

- NOTES:
- A. All linear dimensions are in millimeters.
  - B. This drawing is subject to change without notice.
  - C. Publication IPC-7351 is recommended for alternate design.
  - D. Laser cutting apertures with trapezoidal walls and also rounding corners will offer better paste release. Customers should contact their board assembly site for stencil design recommendations. Refer to IPC-7525 for other stencil recommendations.
  - E. Customers should contact their board fabrication site for solder mask tolerances between and around signal pads.

RGE (S-PVQFN-N24)

PLASTIC QUAD FLATPACK NO-LEAD

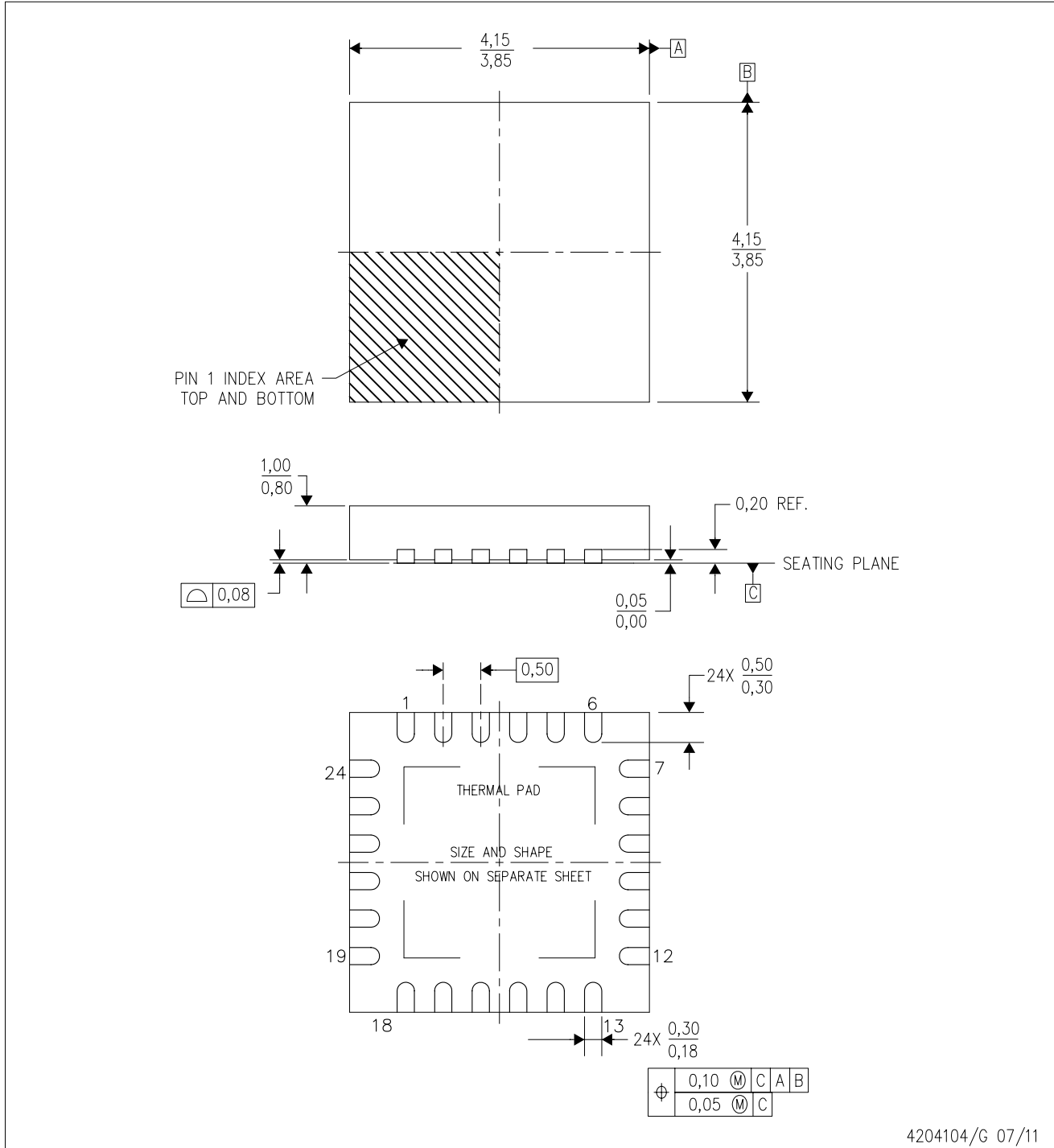

4204104/G 07/11

- NOTES:
- A. All linear dimensions are in millimeters. Dimensioning and tolerancing per ASME Y14.5M-1994.
  - B. This drawing is subject to change without notice.
  - C. Quad Flatpack, No-Leads (QFN) package configuration.
  - D. The package thermal pad must be soldered to the board for thermal and mechanical performance.
  - E. See the additional figure in the Product Data Sheet for details regarding the exposed thermal pad features and dimensions.
  - F. Falls within JEDEC MO-220.

## THERMAL PAD MECHANICAL DATA

RGE (S-PVQFN-N24)

PLASTIC QUAD FLATPACK NO-LEAD

### THERMAL INFORMATION

This package incorporates an exposed thermal pad that is designed to be attached directly to an external heatsink. The thermal pad must be soldered directly to the printed circuit board (PCB). After soldering, the PCB can be used as a heatsink. In addition, through the use of thermal vias, the thermal pad can be attached directly to the appropriate copper plane shown in the electrical schematic for the device, or alternatively, can be attached to a special heatsink structure designed into the PCB. This design optimizes the heat transfer from the integrated circuit (IC).

For information on the Quad Flatpack No-Lead (QFN) package and its advantages, refer to Application Report, QFN/SON PCB Attachment, Texas Instruments Literature No. SLUA271. This document is available at [www.ti.com](http://www.ti.com).

The exposed thermal pad dimensions for this package are shown in the following illustration.

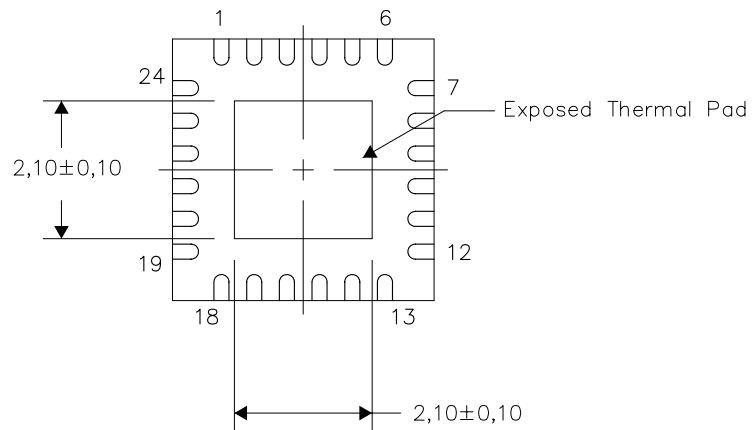

Bottom View

Exposed Thermal Pad Dimensions

4206344-6/X 03/11

NOTES: A. All linear dimensions are in millimeters

# MECHANICAL DATA

RHL (R-PVQFN-N24)

PLASTIC QUAD FLATPACK NO-LEAD

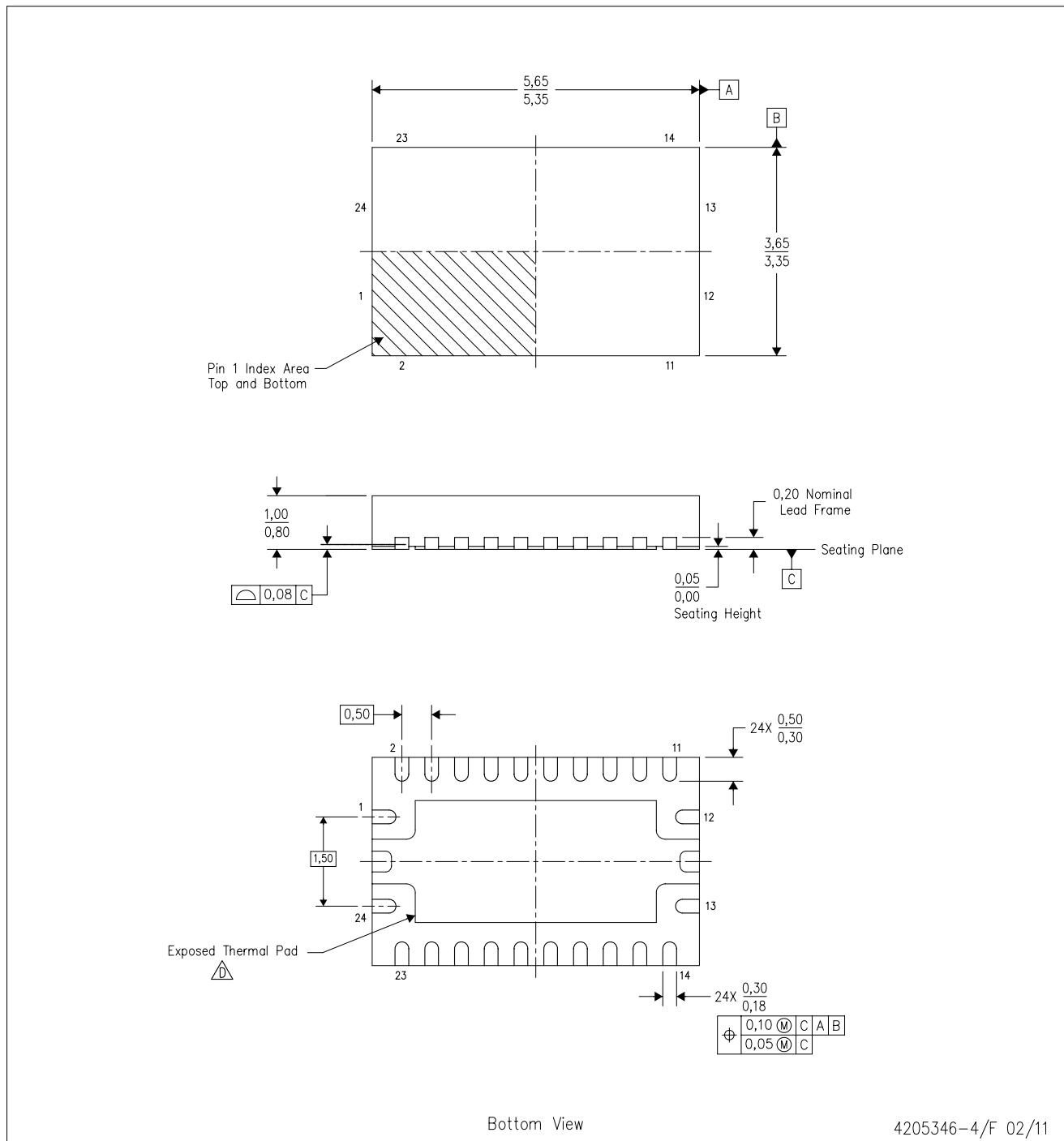

- NOTES:
- A. All linear dimensions are in millimeters. Dimensioning and tolerancing per ASME Y14.5M-1994.
  - B. This drawing is subject to change without notice.
  - C. QFN (Quad Flatpack No-Lead) package configuration.
  -  The package thermal pad must be soldered to the board for thermal and mechanical performance. See the Product Data Sheet for details regarding the exposed thermal pad dimensions.
  - E. JEDEC MO-241 package registration pending.

DB (R-PDSO-G\*\*)

PLASTIC SMALL-OUTLINE

28 PINS SHOWN



- NOTES: A. All linear dimensions are in millimeters.  
 B. This drawing is subject to change without notice.  
 C. Body dimensions do not include mold flash or protrusion not to exceed 0,15.  
 D. Falls within JEDEC MO-150

## IMPORTANT NOTICE

Texas Instruments Incorporated and its subsidiaries (TI) reserve the right to make corrections, modifications, enhancements, improvements, and other changes to its products and services at any time and to discontinue any product or service without notice. Customers should obtain the latest relevant information before placing orders and should verify that such information is current and complete. All products are sold subject to TI's terms and conditions of sale supplied at the time of order acknowledgment.

TI warrants performance of its hardware products to the specifications applicable at the time of sale in accordance with TI's standard warranty. Testing and other quality control techniques are used to the extent TI deems necessary to support this warranty. Except where mandated by government requirements, testing of all parameters of each product is not necessarily performed.

TI assumes no liability for applications assistance or customer product design. Customers are responsible for their products and applications using TI components. To minimize the risks associated with customer products and applications, customers should provide adequate design and operating safeguards.

TI does not warrant or represent that any license, either express or implied, is granted under any TI patent right, copyright, mask work right, or other TI intellectual property right relating to any combination, machine, or process in which TI products or services are used. Information published by TI regarding third-party products or services does not constitute a license from TI to use such products or services or a warranty or endorsement thereof. Use of such information may require a license from a third party under the patents or other intellectual property of the third party, or a license from TI under the patents or other intellectual property of TI.

Reproduction of TI information in TI data books or data sheets is permissible only if reproduction is without alteration and is accompanied by all associated warranties, conditions, limitations, and notices. Reproduction of this information with alteration is an unfair and deceptive business practice. TI is not responsible or liable for such altered documentation. Information of third parties may be subject to additional restrictions.

Resale of TI products or services with statements different from or beyond the parameters stated by TI for that product or service voids all express and any implied warranties for the associated TI product or service and is an unfair and deceptive business practice. TI is not responsible or liable for any such statements.

TI products are not authorized for use in safety-critical applications (such as life support) where a failure of the TI product would reasonably be expected to cause severe personal injury or death, unless officers of the parties have executed an agreement specifically governing such use. Buyers represent that they have all necessary expertise in the safety and regulatory ramifications of their applications, and acknowledge and agree that they are solely responsible for all legal, regulatory and safety-related requirements concerning their products and any use of TI products in such safety-critical applications, notwithstanding any applications-related information or support that may be provided by TI. Further, Buyers must fully indemnify TI and its representatives against any damages arising out of the use of TI products in such safety-critical applications.

TI products are neither designed nor intended for use in military/aerospace applications or environments unless the TI products are specifically designated by TI as military-grade or "enhanced plastic." Only products designated by TI as military-grade meet military specifications. Buyers acknowledge and agree that any such use of TI products which TI has not designated as military-grade is solely at the Buyer's risk, and that they are solely responsible for compliance with all legal and regulatory requirements in connection with such use.

TI products are neither designed nor intended for use in automotive applications or environments unless the specific TI products are designated by TI as compliant with ISO/TS 16949 requirements. Buyers acknowledge and agree that, if they use any non-designated products in automotive applications, TI will not be responsible for any failure to meet such requirements.

Following are URLs where you can obtain information on other Texas Instruments products and application solutions:

### Products

Audio	<a href="http://www.ti.com/audio">www.ti.com/audio</a>
Amplifiers	<a href="http://amplifier.ti.com">amplifier.ti.com</a>
Data Converters	<a href="http://dataconverter.ti.com">dataconverter.ti.com</a>
DLP® Products	<a href="http://www.dlp.com">www.dlp.com</a>
DSP	<a href="http://dsp.ti.com">dsp.ti.com</a>
Clocks and Timers	<a href="http://www.ti.com/clocks">www.ti.com/clocks</a>
Interface	<a href="http://interface.ti.com">interface.ti.com</a>
Logic	<a href="http://logic.ti.com">logic.ti.com</a>
Power Mgmt	<a href="http://power.ti.com">power.ti.com</a>
Microcontrollers	<a href="http://microcontroller.ti.com">microcontroller.ti.com</a>
RFID	<a href="http://www.ti-rfid.com">www.ti-rfid.com</a>
RF/IF and ZigBee® Solutions	<a href="http://www.ti.com/lprf">www.ti.com/lprf</a>

### Applications

Communications and Telecom	<a href="http://www.ti.com/communications">www.ti.com/communications</a>
Computers and Peripherals	<a href="http://www.ti.com/computers">www.ti.com/computers</a>
Consumer Electronics	<a href="http://www.ti.com/consumer-apps">www.ti.com/consumer-apps</a>
Energy and Lighting	<a href="http://www.ti.com/energy">www.ti.com/energy</a>
Industrial	<a href="http://www.ti.com/industrial">www.ti.com/industrial</a>
Medical	<a href="http://www.ti.com/medical">www.ti.com/medical</a>
Security	<a href="http://www.ti.com/security">www.ti.com/security</a>
Space, Avionics and Defense	<a href="http://www.ti.com/space-avionics-defense">www.ti.com/space-avionics-defense</a>
Transportation and Automotive	<a href="http://www.ti.com/automotive">www.ti.com/automotive</a>
Video and Imaging	<a href="http://www.ti.com/video">www.ti.com/video</a>
Wireless	<a href="http://www.ti.com/wireless-apps">www.ti.com/wireless-apps</a>

TI E2E Community Home Page

[e2e.ti.com](http://e2e.ti.com)

Mailing Address: Texas Instruments, Post Office Box 655303, Dallas, Texas 75265  
Copyright © 2011, Texas Instruments Incorporated