

**FEATURES**

- Output Voltage Range Adjustable From 1.25 V to 37 V
- Output Current Greater Than 1.5 A
- Internal Short-Circuit Current Limiting
- Thermal Overload Protection
- Output Safe-Area Compensation

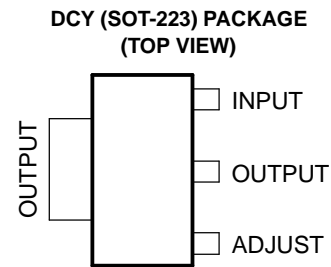
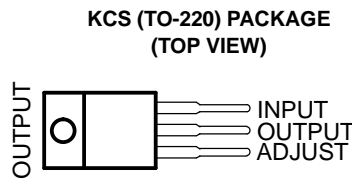
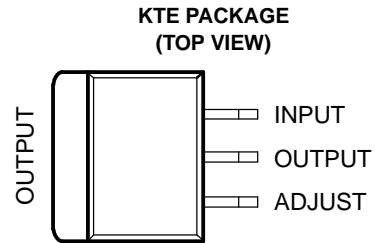
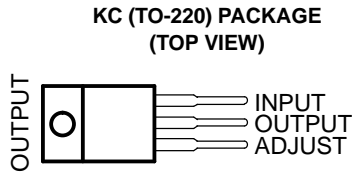

**DESCRIPTION/ORDERING INFORMATION**

The LM317 is an adjustable three-terminal positive-voltage regulator capable of supplying more than 1.5 A over an output-voltage range of 1.25 V to 37 V. It is exceptionally easy to use and requires only two external resistors to set the output voltage. Furthermore, both line and load regulation are better than standard fixed regulators.

In addition to having higher performance than fixed regulators, this device includes on-chip current limiting, thermal overload protection, and safe operating-area protection. All overload protection remains fully functional, even if the ADJUST terminal is disconnected.

The LM317 is versatile in its applications, including uses in programmable output regulation and local on-card regulation. Or, by connecting a fixed resistor between the ADJUST and OUTPUT terminals, the LM317 can function as a precision current regulator. An optional output capacitor can be added to improve transient response. The ADJUST terminal can be bypassed to achieve very high ripple-rejection ratios, which are difficult to achieve with standard three-terminal regulators.

**ORDERING INFORMATION**

T <sub>A</sub>	PACKAGE <sup>(1)</sup>		ORDERABLE PART NUMBER	TOP-SIDE MARKING
0°C to 125°C	PowerFLEX™ – KTE	Reel of 2000	LM317KTER	LM317
	SOT-223 – DCY	Tube of 80	LM317DCY	L3
		Reel of 2500	LM317DCYR	
	TO-220 – KC	Tube of 50	LM317KC	LM317
TO-220, short shoulder – KCS	Tube of 20	LM317KCS		

(1) Package drawings, standard packing quantities, thermal data, symbolization, and PCB design guidelines are available at [www.ti.com/sc/package](http://www.ti.com/sc/package).



Please be aware that an important notice concerning availability, standard warranty, and use in critical applications of Texas Instruments semiconductor products and disclaimers thereto appears at the end of this data sheet.

PowerFLEX, PowerPAD are trademarks of Texas Instruments.

# LM317

## 3-TERMINAL ADJUSTABLE REGULATOR

SLVS044Q—SEPTEMBER 1997—REVISED OCTOBER 2005

### SCHEMATIC DIAGRAM

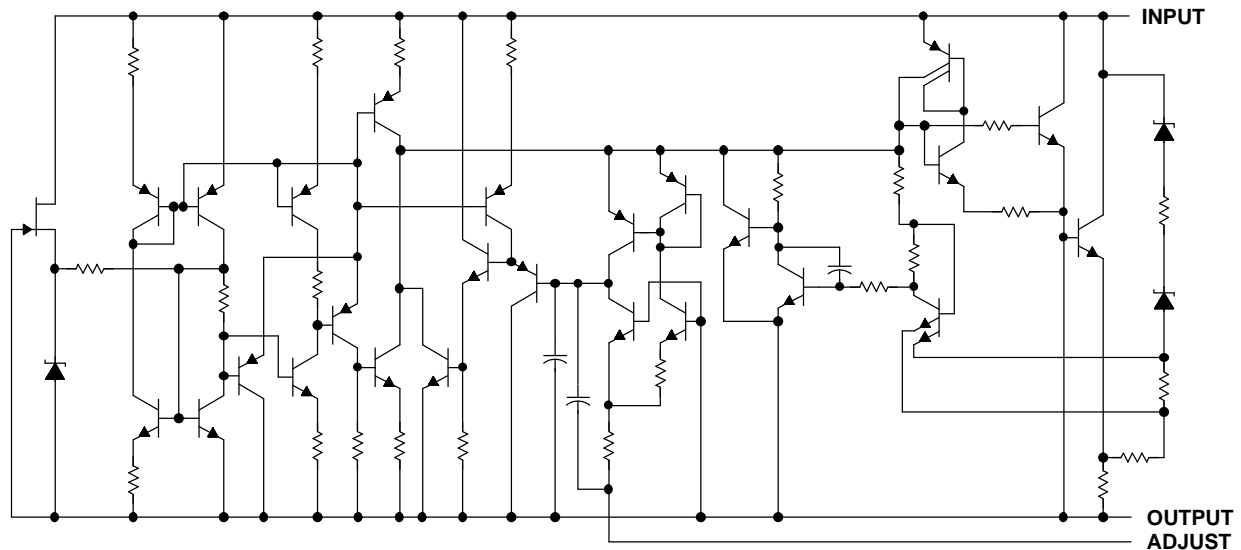

### Absolute Maximum Ratings<sup>(1)</sup>

over virtual junction temperature range (unless otherwise noted)

		MIN	MAX	UNIT
$V_I - V_O$	Input-to-output differential voltage		40	V
$T_J$	Operating virtual junction temperature		150	°C
	Lead temperature 1,6 mm (1/16 in) from case for 10 s		260	°C
$T_{stg}$	Storage temperature range	-65	150	°C

(1) Stresses beyond those listed under "absolute maximum ratings" may cause permanent damage to the device. These are stress ratings only, and functional operation of the device at these or any other conditions beyond those indicated under "recommended operating conditions" is not implied. Exposure to absolute-maximum-rated conditions for extended periods may affect device reliability.

### Package Thermal Data<sup>(1)</sup>

PACKAGE	BOARD	$\theta_{JA}$	$\theta_{JC}$	$\theta_{JP}$ <sup>(2)</sup>
PowerFLEX™ (KTE)	High K, JESD 51-5	23°C/W	3°C/W	
SOT-223 (DCY)	High K, JESD 51-7	53°C/W	30.6°C/W	
TO-220 (KC/KCS)	High K, JESD 51-5	19°C/W	17°C/W	3°C/W

- (1) Maximum power dissipation is a function of  $T_J(\max)$ ,  $\theta_{JA}$ , and  $T_A$ . The maximum allowable power dissipation at any allowable ambient temperature is  $P_D = (T_J(\max) - T_A)/\theta_{JA}$ . Operating at the absolute maximum  $T_J$  of 150°C can affect reliability.
- (2) For packages with exposed thermal pads, such as QFN, PowerPAD™, or PowerFLEX™,  $\theta_{JP}$  is defined as the thermal resistance between the die junction and the bottom of the exposed pad.

### Recommended Operating Conditions

		MIN	MAX	UNIT
$V_I - V_O$	Input-to-output differential voltage	3	40	V
$I_O$	Output current		1.5	A
$T_J$	Operating virtual junction temperature	0	125	°C

### Electrical Characteristics

over recommended ranges of operating virtual junction temperature (unless otherwise noted)

PARAMETER	TEST CONDITIONS <sup>(1)</sup>		MIN	TYP	MAX	UNIT
Line regulation <sup>(2)</sup>	$V_I - V_O = 3\text{ V to }40\text{ V}$		$T_J = 25^\circ\text{C}$	0.01	0.04	%V
			$T_J = 0^\circ\text{C to }125^\circ\text{C}$	0.02	0.07	
Load regulation	$I_O = 10\text{ mA to }1500\text{ mA}$	$C_{ADJ} = 10\ \mu\text{F},$ <sup>(3)</sup> $T_J = 25^\circ\text{C}$	$V_O \leq 5\text{ V}$		25	mV
			$V_O \geq 5\text{ V}$	0.1	0.5	% $V_O$
		$T_J = 0^\circ\text{C to }125^\circ\text{C}$	$V_O \leq 5\text{ V}$	20	70	mV
			$V_O \geq 5\text{ V}$	0.3	1.5	% $V_O$
Thermal regulation	20-ms pulse,	$T_J = 25^\circ\text{C}$	0.03	0.07	% $V_O/W$	
ADJUST terminal current			50	100	$\mu\text{A}$	
Change in ADJUST terminal current	$V_I - V_O = 2.5\text{ V to }40\text{ V}, P_D \leq 20\text{ W}, I_O = 10\text{ mA to }1500\text{ mA}$		0.2	5	$\mu\text{A}$	
Reference voltage	$V_I - V_O = 3\text{ V to }40\text{ V}, P_D \leq 20\text{ W}, I_O = 10\text{ mA to }1500\text{ mA}$		1.2	1.25	1.3	V
Output-voltage temperature stability	$T_J = 0^\circ\text{C to }125^\circ\text{C}$		0.7			% $V_O$
Minimum load current to maintain regulation	$V_I - V_O = 40\text{ V}$		3.5	10		mA
Maximum output current	$V_I - V_O \leq 15\text{ V},$	$P_D < P_{MAX}$ <sup>(4)</sup>	1.5	2.2		A
	$V_I - V_O \leq 40\text{ V},$	$P_D < P_{MAX}$ <sup>(4),</sup> $T_J = 25^\circ\text{C}$	0.15	0.4		
RMS output noise voltage (% of $V_O$ )	$f = 10\text{ Hz to }10\text{ kHz},$	$T_J = 25^\circ\text{C}$	0.003			% $V_O$
Ripple rejection	$V_O = 10\text{ V},$	$f = 120\text{ Hz}$	$C_{ADJ} = 0\ \mu\text{F}$ <sup>(3)</sup>	57		dB
			$C_{ADJ} = 10\ \mu\text{F}$ <sup>(3)</sup>	62	64	
Long-term stability	$T_J = 25^\circ\text{C}$		0.3	1		%/1k hr

- (1) Unless otherwise noted, the following test conditions apply:  $|V_I - V_O| = 5\text{ V}$  and  $I_{O\text{MAX}} = 1.5\text{ A}$ ,  $T_J = 0^\circ\text{C to }125^\circ\text{C}$ . Pulse testing techniques are used to maintain the junction temperature as close to the ambient temperature as possible.
- (2) Line regulation is expressed here as the percentage change in output voltage per 1-V change at the input.
- (3)  $C_{ADJ}$  is connected between the ADJUST terminal and GND.
- (4) Maximum power dissipation is a function of  $T_{J(\text{max})}$ ,  $\theta_{JA}$ , and  $T_A$ . The maximum allowable power dissipation at any allowable ambient temperature is  $P_D = (T_{J(\text{max})} - T_A)/\theta_{JA}$ . Operating at the absolute maximum  $T_J$  of  $150^\circ\text{C}$  can affect reliability.

TYPICAL CHARACTERISTICS

LOAD REGULATION

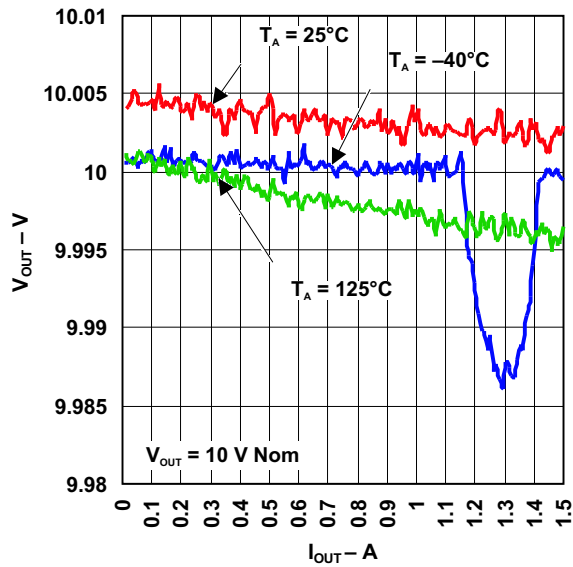

LOAD REGULATION

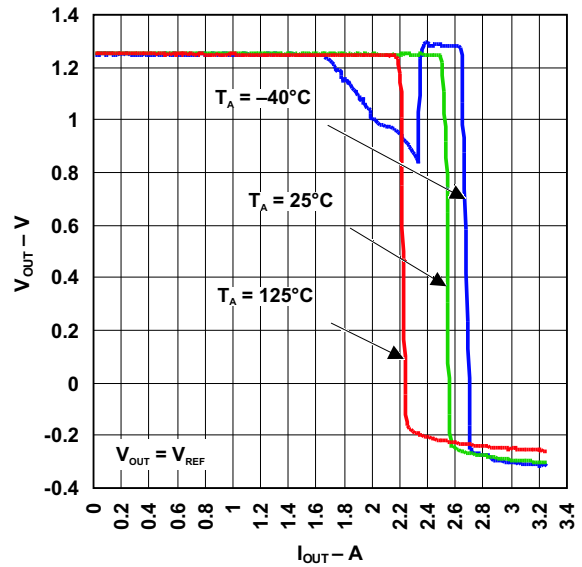

LOAD TRANSIENT RESPONSE

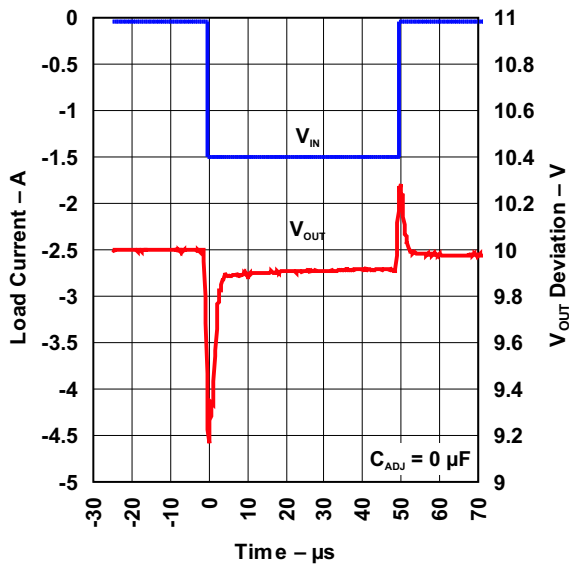

LOAD TRANSIENT RESPONSE

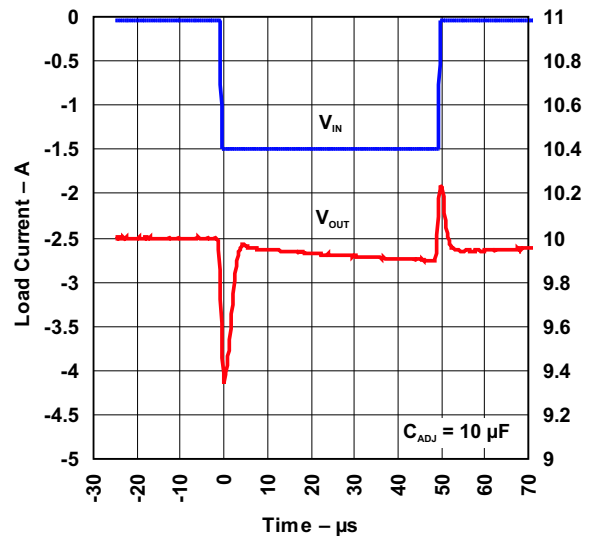

**TYPICAL CHARACTERISTICS (continued)**

**LINE REGULATION**

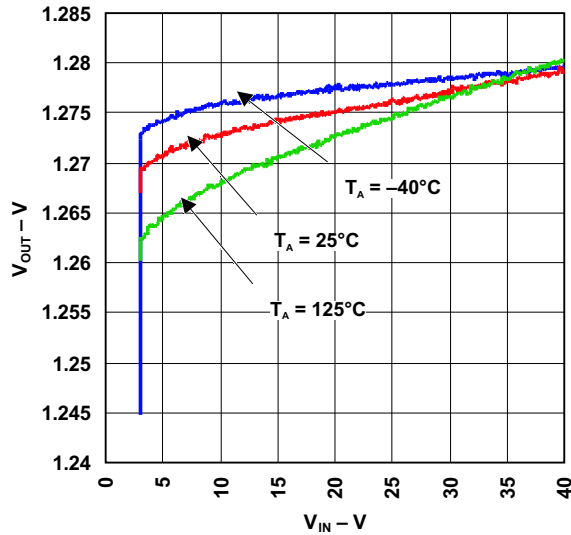

**LINE TRANSIENT RESPONSE**

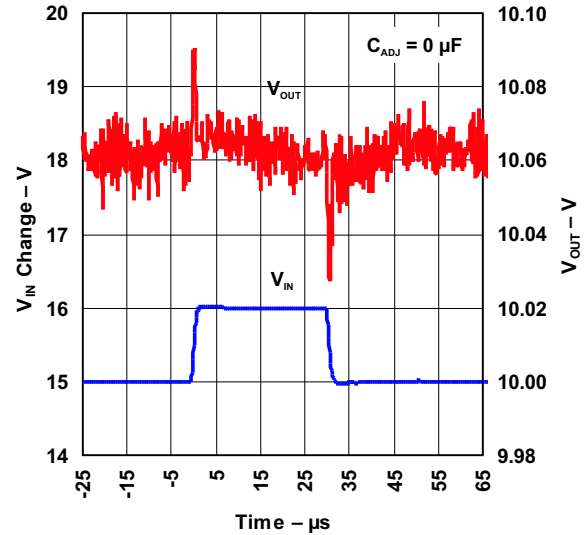

**LINE TRANSIENT RESPONSE**

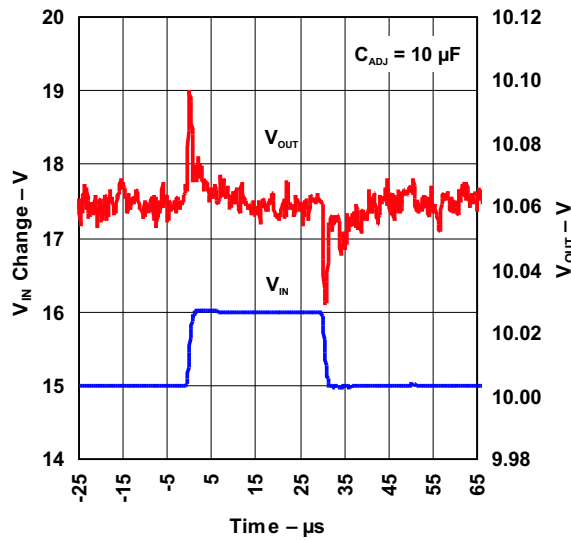

**RIPPLE REJECTION VS FREQUENCY**

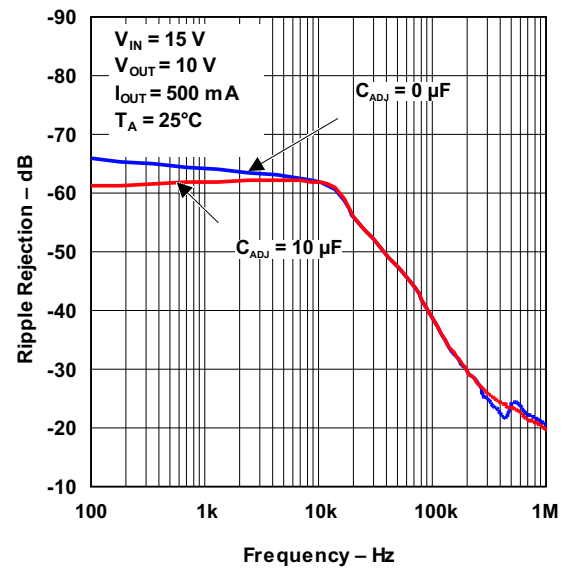

# LM317 3-TERMINAL ADJUSTABLE REGULATOR

SLVS044Q-SEPTEMBER 1997-REVISED OCTOBER 2005

## TYPICAL CHARACTERISTICS (continued)

**RIPPLE REJECTION  
VS  
OUTPUT CURRENT**

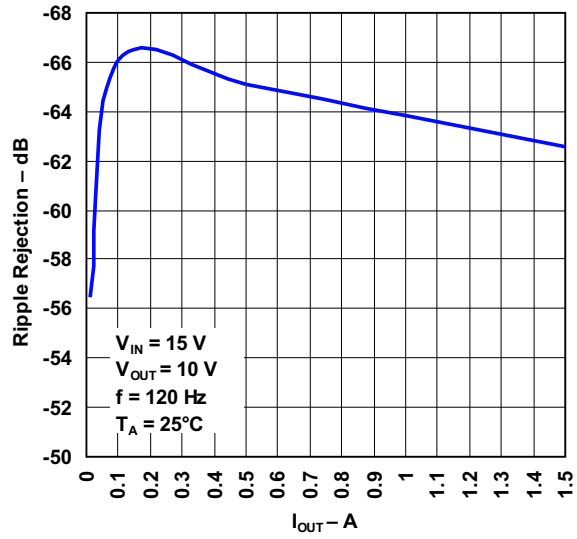

**RIPPLE REJECTION  
VS  
OUTPUT VOLTAGE**

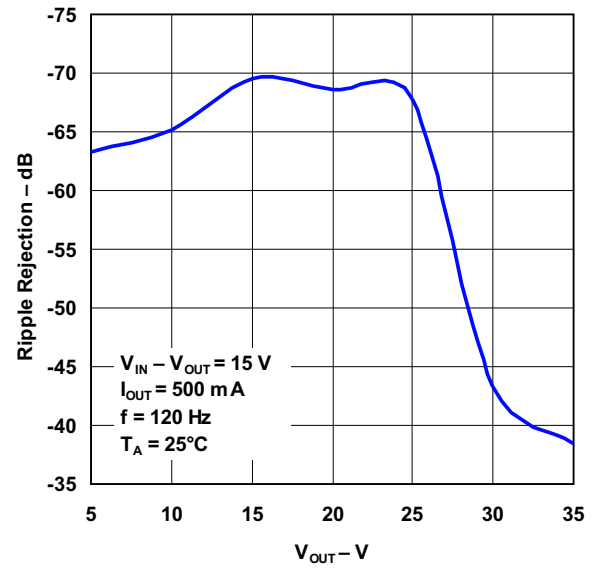

**APPLICATION INFORMATION**

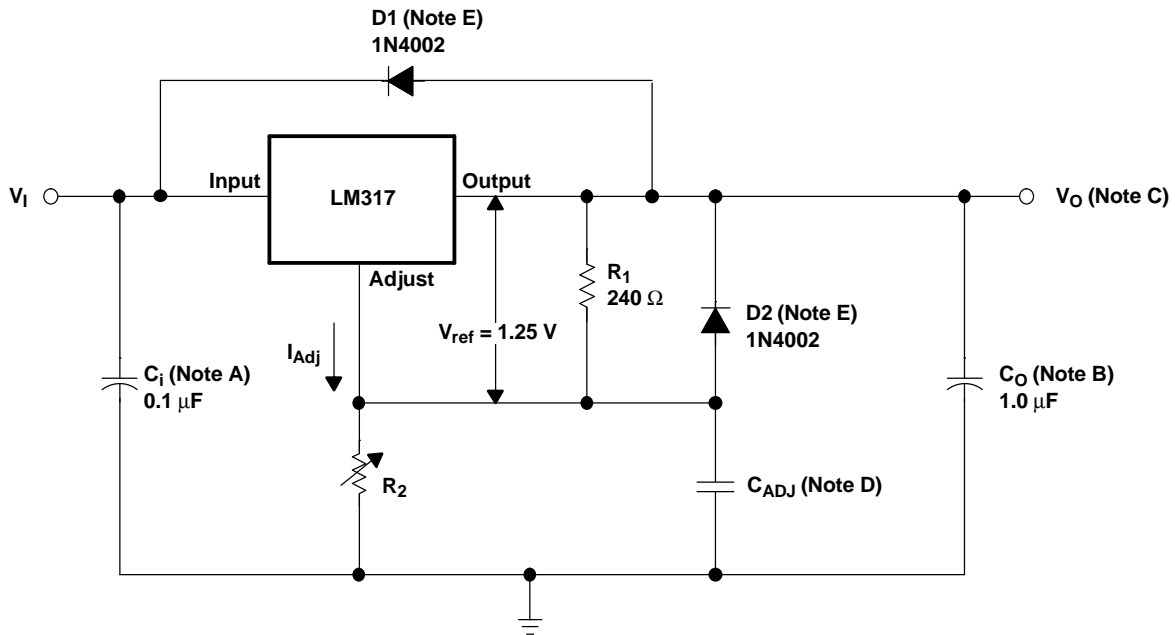

- NOTES:
- A.  $C_i$  is not required, but is recommended, particularly if the regulator is not in close proximity to the power-supply filter capacitors. A 0.1- $\mu$ F disc or 1- $\mu$ F tantalum provides sufficient bypassing for most applications, especially when adjustment and output capacitors are used.
  - B.  $C_O$  improves transient response, but is not needed for stability.
  - C.  $V_O$  is calculated as shown:

$$V_O = V_{ref} \left( 1 + \frac{R_2}{R_1} \right) + (I_{Adj} \times R_2)$$

Because  $I_{Adj}$  typically is 50  $\mu$ A, it is negligible in most applications.

- D.  $C_{ADJ}$  is used to improve ripple rejection; it prevents amplification of the ripple as the output voltage is adjusted higher. If  $C_{ADJ}$  is used, it is best to include protection diodes.
- E. If the input is shorted to ground during a fault condition, protection diodes provide measures to prevent the possibility of external capacitors discharging through low-impedance paths in the IC. By providing low-impedance discharge paths for  $C_O$  and  $C_{ADJ}$ , respectively, D1 and D2 prevent the capacitors from discharging into the output of the regulator.

**Figure 1. Adjustable Voltage Regulator**

APPLICATION INFORMATION (continued)

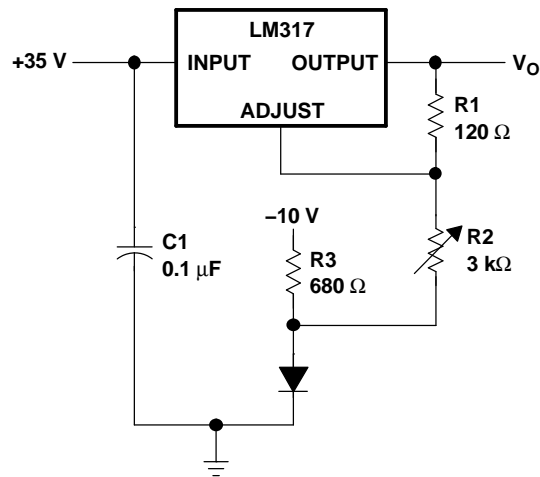

$V_O$  is calculated as:

$$V_O = V_{ref} \left( 1 + \frac{R_2 + R_3}{R_1} \right) + I_{Adj}(R_2 + R_3) - 10 \text{ V}$$

Since  $I_{Adj}$  typically is  $50 \mu\text{A}$ , it is negligible in most applications.

Figure 2. 0-V to 30-V Regulator Circuit

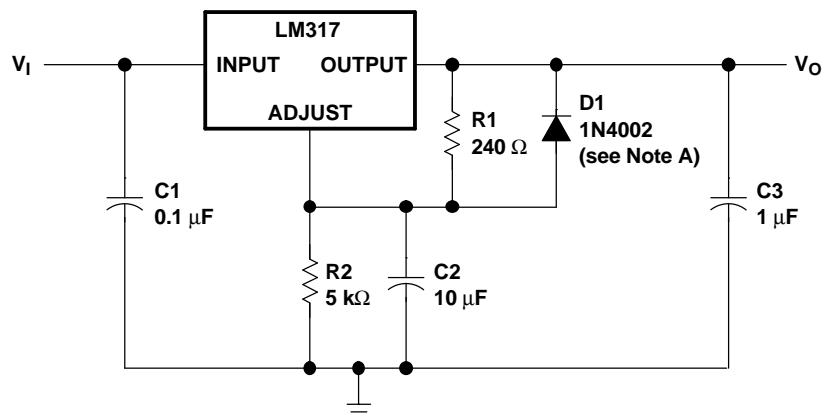

NOTE A: D1 discharges C2 if the output is shorted to ground.

Figure 3. Adjustable Regulator Circuit With Improved Ripple Rejection

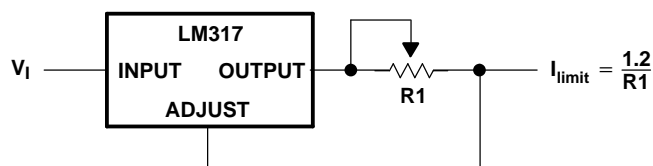

Figure 4. Precision Current-Limiter Circuit

APPLICATION INFORMATION (continued)

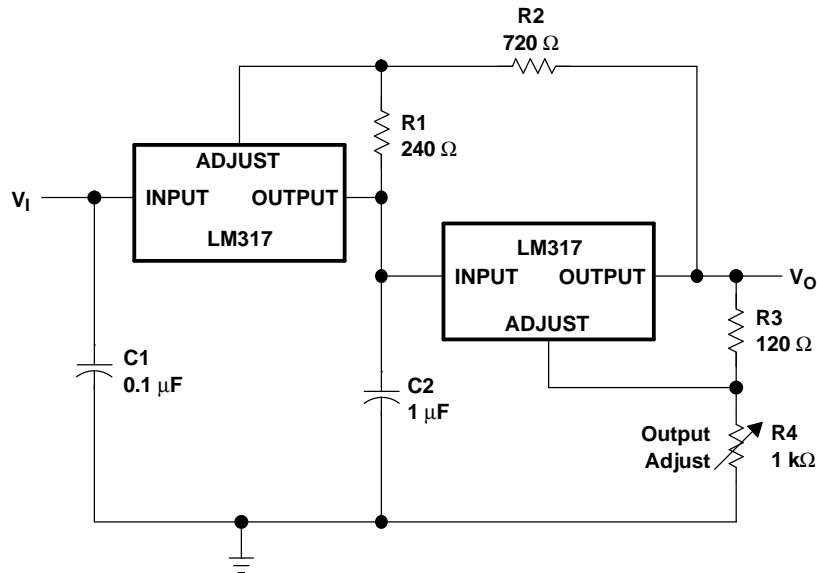

Figure 5. Tracking Preregulator Circuit

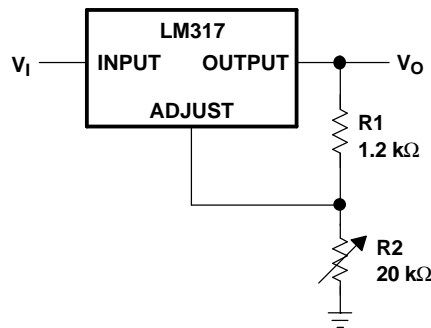
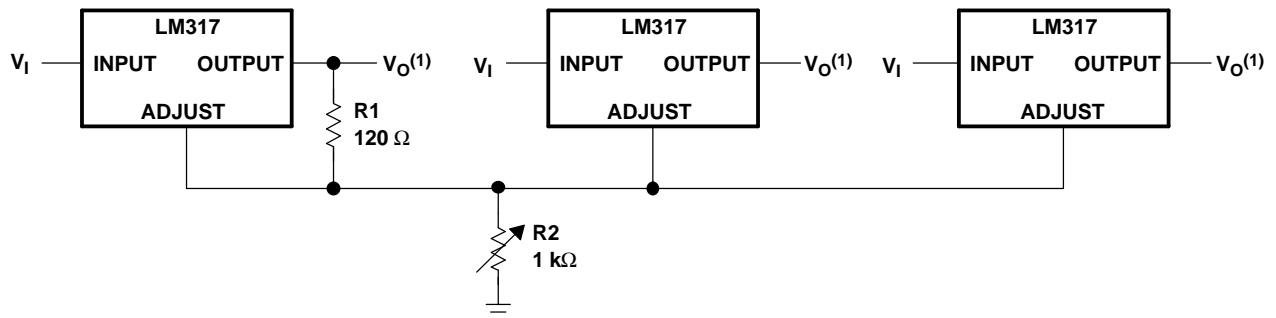

Figure 6. 1.25-V to 20-V Regulator Circuit With Minimum Program Current



(1) Minimum load current from each output is 10 mA. All output voltages are within 200 mV of each other.

Figure 7. Adjusting Multiple On-Card Regulators With a Single Control

APPLICATION INFORMATION (continued)

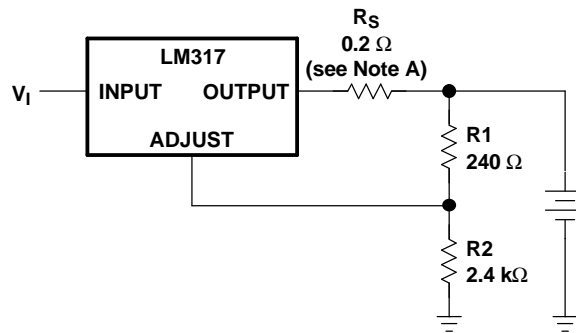

NOTE A:  $R_S$  controls the output impedance of the charger.

$$Z_{OUT} = R_S \left( 1 + \frac{R_2}{R_1} \right)$$

The use of  $R_S$  allows for low charging rates with a fully charged battery.

Figure 8. Battery-Charger Circuit

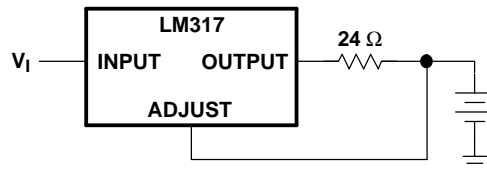

Figure 9. 50-mA Constant-Current Battery-Charger Circuit

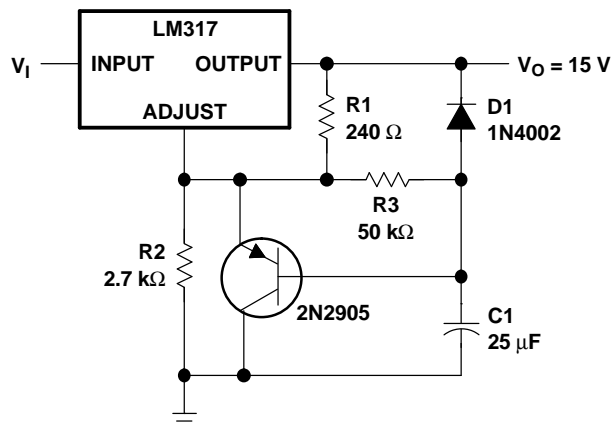
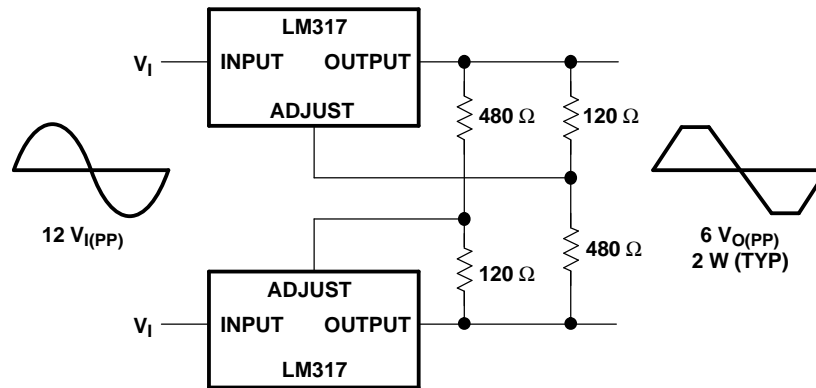
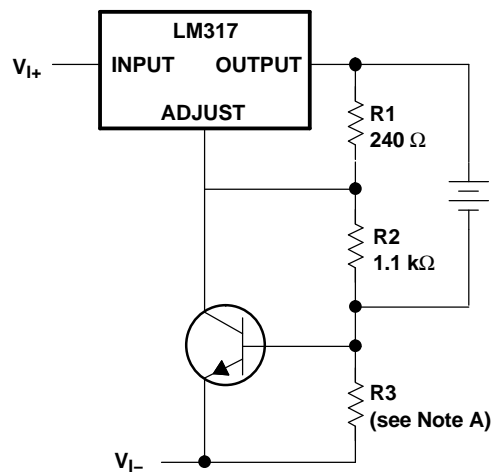

Figure 10. Slow Turn-On 15-V Regulator Circuit

**APPLICATION INFORMATION (continued)**



**Figure 11. AC Voltage-Regulator Circuit**



NOTE A: R3 sets the peak current (0.6 A for a 1-Ω resistor).

**Figure 12. Current-Limited 6-V Charger Circuit**



**PACKAGING INFORMATION**

Orderable Device	Status <sup>(1)</sup>	Package Type	Package Drawing	Pins	Package Qty	Eco Plan <sup>(2)</sup>	Lead/Ball Finish	MSL Peak Temp <sup>(3)</sup>
LM317DCY	ACTIVE	SOT-223	DCY	4		TBD	Call TI	Call TI
LM317DCYG3	ACTIVE	SOT-223	DCY	4		TBD	Call TI	Call TI
LM317DCYR	ACTIVE	SOT-223	DCY	4		TBD	Call TI	Call TI
LM317DCYRG3	ACTIVE	SOT-223	DCY	4		TBD	Call TI	Call TI
LM317KC	OBSOLETE	TO-220	KC	3		TBD	Call TI	Call TI
LM317KCS	ACTIVE	TO-220	KCS	3		TBD	Call TI	Call TI
LM317KCSE3	ACTIVE	TO-220	KCS	3		TBD	Call TI	Call TI
LM317KTER	OBSOLETE	PFM	KTE	3		TBD	Call TI	Call TI

<sup>(1)</sup> The marketing status values are defined as follows:

**ACTIVE:** Product device recommended for new designs.

**LIFEBUY:** TI has announced that the device will be discontinued, and a lifetime-buy period is in effect.

**NRND:** Not recommended for new designs. Device is in production to support existing customers, but TI does not recommend using this part in a new design.

**PREVIEW:** Device has been announced but is not in production. Samples may or may not be available.

**OBSOLETE:** TI has discontinued the production of the device.

<sup>(2)</sup> Eco Plan - The planned eco-friendly classification: Pb-Free (RoHS), Pb-Free (RoHS Exempt), or Green (RoHS & no Sb/Br) - please check <http://www.ti.com/productcontent> for the latest availability information and additional product content details.

**TBD:** The Pb-Free/Green conversion plan has not been defined.

**Pb-Free (RoHS):** TI's terms "Lead-Free" or "Pb-Free" mean semiconductor products that are compatible with the current RoHS requirements for all 6 substances, including the requirement that lead not exceed 0.1% by weight in homogeneous materials. Where designed to be soldered at high temperatures, TI Pb-Free products are suitable for use in specified lead-free processes.

**Pb-Free (RoHS Exempt):** This component has a RoHS exemption for either 1) lead-based flip-chip solder bumps used between the die and package, or 2) lead-based die adhesive used between the die and leadframe. The component is otherwise considered Pb-Free (RoHS compatible) as defined above.

**Green (RoHS & no Sb/Br):** TI defines "Green" to mean Pb-Free (RoHS compatible), and free of Bromine (Br) and Antimony (Sb) based flame retardants (Br or Sb do not exceed 0.1% by weight in homogeneous material)

<sup>(3)</sup> MSL, Peak Temp. -- The Moisture Sensitivity Level rating according to the JEDEC industry standard classifications, and peak solder temperature.

**Important Information and Disclaimer:**The information provided on this page represents TI's knowledge and belief as of the date that it is provided. TI bases its knowledge and belief on information provided by third parties, and makes no representation or warranty as to the accuracy of such information. Efforts are underway to better integrate information from third parties. TI has taken and continues to take reasonable steps to provide representative and accurate information but may not have conducted destructive testing or chemical analysis on incoming materials and chemicals. TI and TI suppliers consider certain information to be proprietary, and thus CAS numbers and other limited information may not be available for release.

In no event shall TI's liability arising out of such information exceed the total purchase price of the TI part(s) at issue in this document sold by TI to Customer on an annual basis.

DCY (R-PDSO-G4)

PLASTIC SMALL-OUTLINE

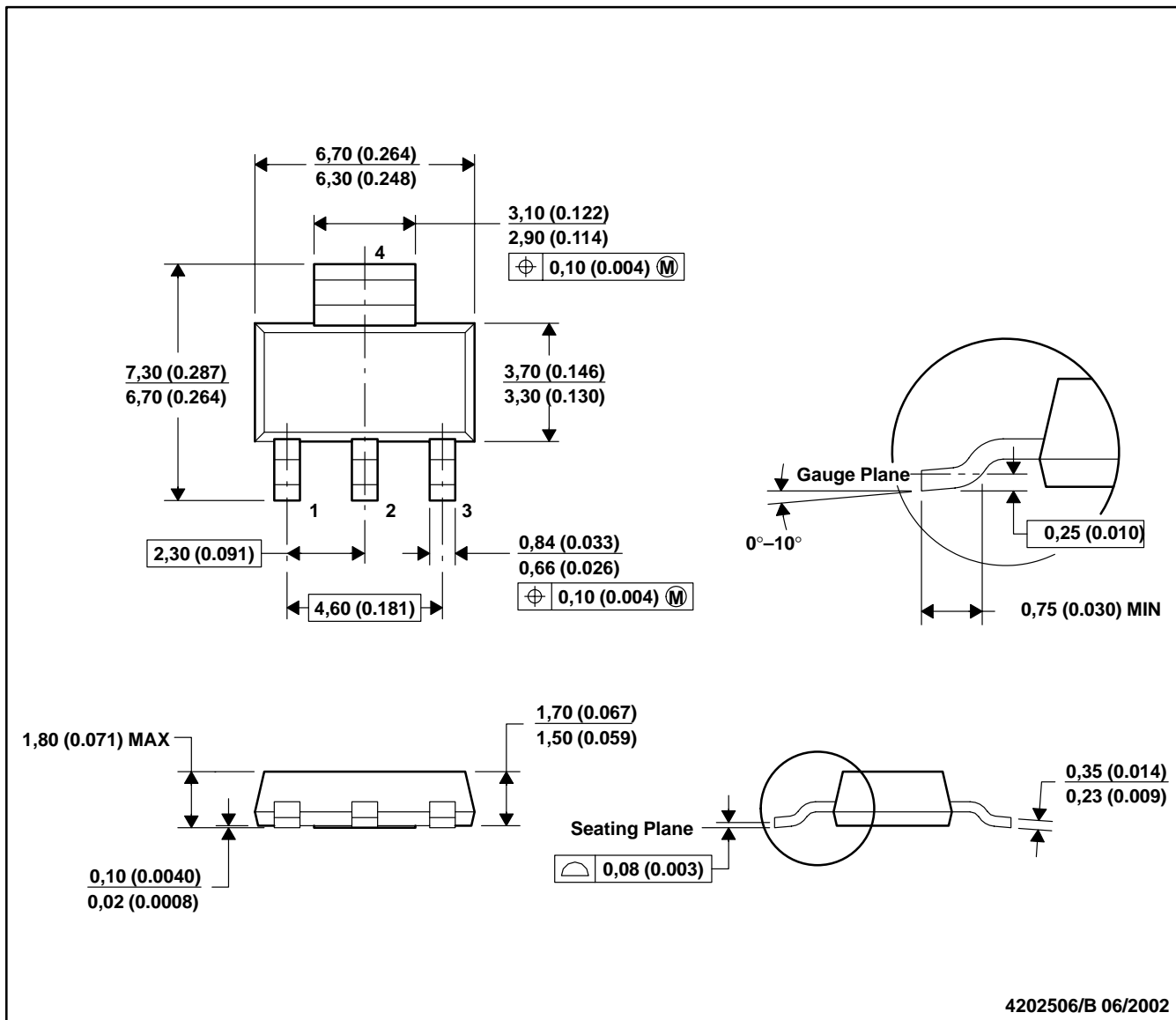

- NOTES: A. All linear dimensions are in millimeters (inches).  
 B. This drawing is subject to change without notice.  
 C. Body dimensions do not include mold flash or protrusion.  
 D. Falls within JEDEC TO-261 Variation AA.

KTE (R-PSFM-G3)

PowerFLEX™ PLASTIC FLANGE-MOUNT

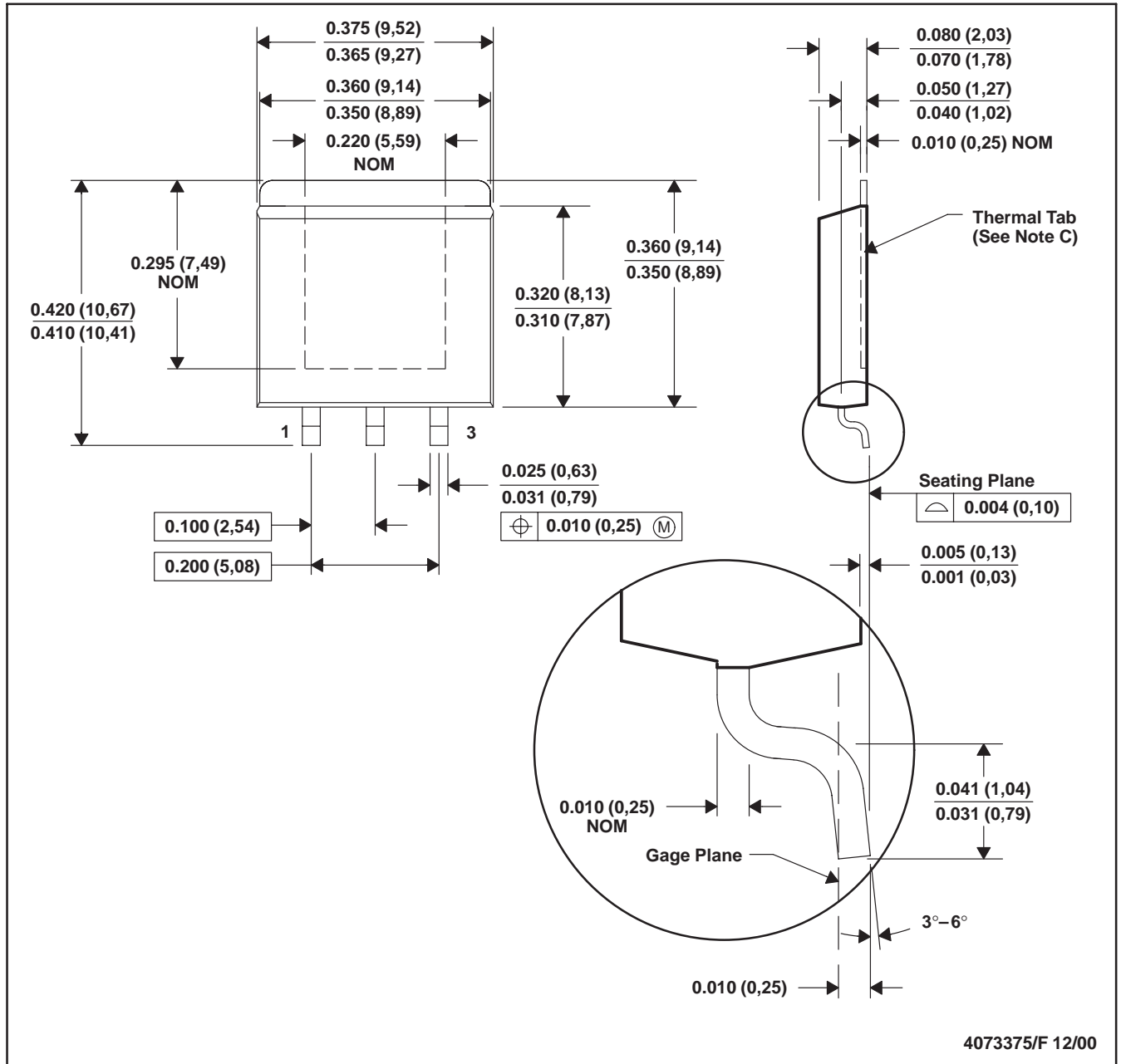

- NOTES: A. All linear dimensions are in inches (millimeters).  
 B. This drawing is subject to change without notice.  
 C. The center lead is in electrical contact with the thermal tab.  
 D. Dimensions do not include mold protrusions, not to exceed 0.006 (0,15).  
 E. Falls within JEDEC MO-169

PowerFLEX is a trademark of Texas Instruments.







## IMPORTANT NOTICE

Texas Instruments Incorporated and its subsidiaries (TI) reserve the right to make corrections, modifications, enhancements, improvements, and other changes to its products and services at any time and to discontinue any product or service without notice. Customers should obtain the latest relevant information before placing orders and should verify that such information is current and complete. All products are sold subject to TI's terms and conditions of sale supplied at the time of order acknowledgment.

TI warrants performance of its hardware products to the specifications applicable at the time of sale in accordance with TI's standard warranty. Testing and other quality control techniques are used to the extent TI deems necessary to support this warranty. Except where mandated by government requirements, testing of all parameters of each product is not necessarily performed.

TI assumes no liability for applications assistance or customer product design. Customers are responsible for their products and applications using TI components. To minimize the risks associated with customer products and applications, customers should provide adequate design and operating safeguards.

TI does not warrant or represent that any license, either express or implied, is granted under any TI patent right, copyright, mask work right, or other TI intellectual property right relating to any combination, machine, or process in which TI products or services are used. Information published by TI regarding third-party products or services does not constitute a license from TI to use such products or services or a warranty or endorsement thereof. Use of such information may require a license from a third party under the patents or other intellectual property of the third party, or a license from TI under the patents or other intellectual property of TI.

Reproduction of information in TI data books or data sheets is permissible only if reproduction is without alteration and is accompanied by all associated warranties, conditions, limitations, and notices. Reproduction of this information with alteration is an unfair and deceptive business practice. TI is not responsible or liable for such altered documentation.

Resale of TI products or services with statements different from or beyond the parameters stated by TI for that product or service voids all express and any implied warranties for the associated TI product or service and is an unfair and deceptive business practice. TI is not responsible or liable for any such statements.

Following are URLs where you can obtain information on other Texas Instruments products and application solutions:

<b>Products</b>		<b>Applications</b>	
Amplifiers	<a href="http://amplifier.ti.com">amplifier.ti.com</a>	Audio	<a href="http://www.ti.com/audio">www.ti.com/audio</a>
Data Converters	<a href="http://dataconverter.ti.com">dataconverter.ti.com</a>	Automotive	<a href="http://www.ti.com/automotive">www.ti.com/automotive</a>
DSP	<a href="http://dsp.ti.com">dsp.ti.com</a>	Broadband	<a href="http://www.ti.com/broadband">www.ti.com/broadband</a>
Interface	<a href="http://interface.ti.com">interface.ti.com</a>	Digital Control	<a href="http://www.ti.com/digitalcontrol">www.ti.com/digitalcontrol</a>
Logic	<a href="http://logic.ti.com">logic.ti.com</a>	Military	<a href="http://www.ti.com/military">www.ti.com/military</a>
Power Mgmt	<a href="http://power.ti.com">power.ti.com</a>	Optical Networking	<a href="http://www.ti.com/opticalnetwork">www.ti.com/opticalnetwork</a>
Microcontrollers	<a href="http://microcontroller.ti.com">microcontroller.ti.com</a>	Security	<a href="http://www.ti.com/security">www.ti.com/security</a>
		Telephony	<a href="http://www.ti.com/telephony">www.ti.com/telephony</a>
		Video & Imaging	<a href="http://www.ti.com/video">www.ti.com/video</a>
		Wireless	<a href="http://www.ti.com/wireless">www.ti.com/wireless</a>

Mailing Address: Texas Instruments  
Post Office Box 655303 Dallas, Texas 75265

Copyright © 2006, Texas Instruments Incorporated