

LM2900, LM3900 QUADRUPLE NORTON OPERATIONAL AMPLIFIERS

SLOS059 – JULY 1979 – REVISED SEPTEMBER 1990

- Wide Range of Supply Voltages, Single or Dual Supplies
- Wide Bandwidth
- Large Output Voltage Swing
- Output Short-Circuit Protection
- Internal Frequency Compensation
- Low Input Bias Current
- Designed to Be Interchangeable With National Semiconductor LM2900 and LM3900, Respectively

N PACKAGE
(TOP VIEW)

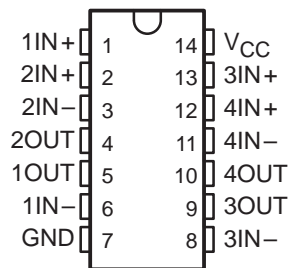

description

These devices consist of four independent, high-gain frequency-compensated Norton operational amplifiers that were designed specifically to operate from a single supply over a wide range of voltages. Operation from split supplies is also possible. The low supply current drain is essentially independent of the magnitude of the supply voltage. These devices provide wide bandwidth and large output voltage swing.

The LM2900 is characterized for operation from -40°C to 85°C, and the LM3900 is characterized for operation from 0°C to 70°C.

symbol (each amplifier)

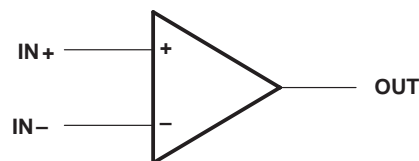

schematic (each amplifier)

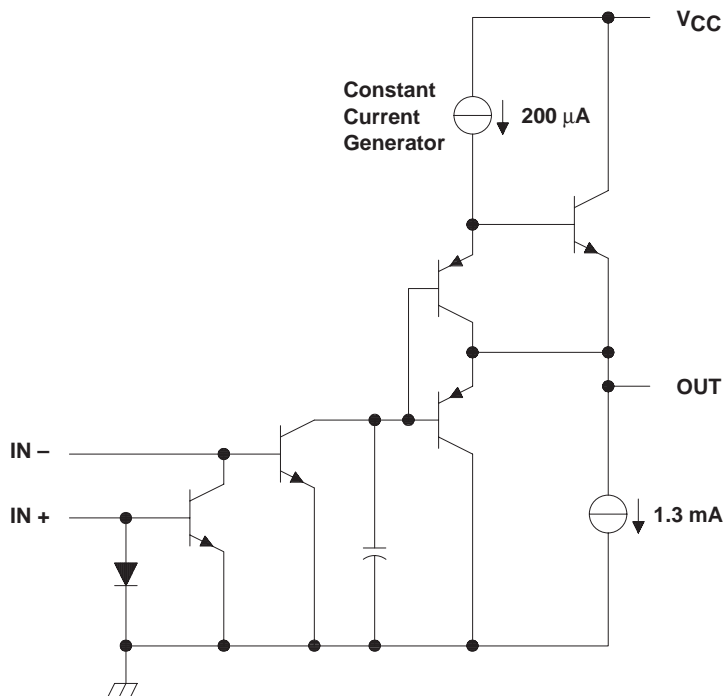

PRODUCTION DATA information is current as of publication date. Products conform to specifications per the terms of Texas Instruments standard warranty. Production processing does not necessarily include testing of all parameters.

 **TEXAS
INSTRUMENTS**

POST OFFICE BOX 655303 • DALLAS, TEXAS 75265

Copyright © 1990, Texas Instruments Incorporated

LM2900, LM3900 QUADRUPLE NORTON OPERATIONAL AMPLIFIERS

SLOS059 – JULY 1979 – REVISED SEPTEMBER 1990

absolute maximum ratings over operating free-air temperature range (unless otherwise noted)

	LM2900	LM3900	UNIT
Supply voltage, V_{CC} (see Note 1)	36	36	V
Input current	20	20	mA
Duration of output short circuit (one amplifier) to ground at (or below) 25°C free-air temperature (see Note 2)	unlimited	unlimited	
Continuous total dissipation	See Dissipation Rating Table		
Operating free-air temperature range	-40 to 85	0 to 70	°C
Storage temperature range	-65 to 150	-65 to 150	°C
Lead temperature 1,6 mm (1/16 inch) from case for 10 seconds	260	260	°C

NOTES: 1. All voltage values, except differential voltages, are with respect to the network ground terminal.
2. Short circuits from outputs to V_{CC} can cause excessive heating and eventual destruction.

DISSIPATION RATING TABLE

PACKAGE	$T_A \leq 25^\circ\text{C}$ POWER RATING	DERATING FACTOR ABOVE $T_A = 25^\circ\text{C}$	$T_A = 70^\circ\text{C}$ POWER RATING	$T_A = 85^\circ\text{C}$ POWER RATING
N	1150 mW	9.2 mW/°C	736 mW	598 mW

recommended operating conditions

	LM2900		LM3900		UNIT
	MIN	MAX	MIN	MAX	
Supply voltage, V_{CC} (single supply)	4.5	32	4.5	32	V
Supply voltage, V_{CC+} (dual supply)	2.2	16	2.2	16	V
Supply voltage, V_{CC-} (dual supply)	-2.2	-16	-2.2	-16	V
Input current (see Note 3)		-1		-1	mA
Operating free-air temperature, T_A	-40	85	0	70	°C

NOTE 3: Clamp transistors are included that prevent the input voltages from swinging below ground more than approximately -0.3 V. The negative input currents that may result from large signal overdrive with capacitive input coupling must be limited externally to values of approximately -1 mA. Negative input currents in excess of -4 mA causes the output voltage to drop to a low voltage. These values apply for any one of the input terminals. If more than one of the input terminals are simultaneously driven negative, maximum currents are reduced. Common-mode current biasing can be used to prevent negative input voltages.

LM2900, LM3900

QUADRUPLE NORTON OPERATIONAL AMPLIFIERS

SLOS059 – JULY 1979 – REVISED SEPTEMBER 1990

electrical characteristics, $V_{CC} = 15\text{ V}$, $T_A = 25^\circ\text{C}$ (unless otherwise noted)

PARAMETER	TEST CONDITION†		LM2900			LM3900			UNIT
			MIN	TYP	MAX	MIN	TYP	MAX	
I_{IB} Input bias current (inverting input)	$I_{I+} = 0$	$T_A = 25^\circ\text{C}$	30	200		30	200	nA	
		$T_A = \text{Full range}$		300		300			
Mirror gain	$I_{I+} = 20\ \mu\text{A}$ to $200\ \mu\text{A}$ $T_A = \text{Full range}$, See Note 4		0.9		1.1	0.9		1.1	$\mu\text{A}/\mu\text{A}$
Change in mirror gain				2%		5%	2%		5%
Mirror current	$V_{I+} = V_{I-}$, See Note 4	$T_A = \text{Full range}$,		10	500		10	500	μA
A_{VD} Large-signal differential voltage amplification	$V_O = 10\text{ V}$, $f = 100\text{ Hz}$	$R_L = 10\text{ k}\Omega$,	1.2	2.8		1.2	2.8		V/mV
r_i Input resistance (inverting input)				1			1		M Ω
r_o Output resistance				8			8		k Ω
B_1 Unity-gain bandwidth (inverting input)				2.5			2.5		MHz
k_{SVR} Supply voltage rejection ratio ($\Delta V_{CC}/\Delta V_{IO}$)				70			70		dB
V_{OH} High-level output voltage	$I_{I+} = 0$, $I_{I-} = 0$	$R_L = 2\text{ k}\Omega$		13.5			13.5		V
		$V_{CC} = 30\text{ V}$, No load		29.5			29.5		
V_{OL} Low-level output voltage	$I_{I+} = 0$, $R_L = 2\text{ k}\Omega$	$I_{I-} = 10\ \mu\text{A}$,		0.09	0.2		0.09	0.2	V
I_{OS} Short-circuit output current (output internally high)	$I_{I+} = 0$, $V_O = 0$	$I_{I-} = 0$,		-6	-18		-6	-10	mA
			Pulldown current		0.5	1.3		0.5	
I_{OL} Low-level output current‡	$I_{I-} = 5\ \mu\text{A}$	$V_{OL} = 1\text{ V}$		5			5		mA
I_{CC} Supply current (four amplifiers)	No load			6.2	10		6.2	10	mA

† All characteristics are measured under open-loop conditions with zero common-mode voltage unless otherwise specified. Full range for T_A is -40°C to 85°C for LM2900 and 0°C to 70°C for LM3900.

‡ The output current-sink capability can be increased for large-signal conditions by overdriving the inverting input.

NOTE 4: These parameters are measured with the output balanced midway between V_{CC} and GND.

operating characteristics, $V_{CC\pm} = \pm 15\text{ V}$, $T_A = 25^\circ\text{C}$

PARAMETER	TEST CONDITIONS			MIN	TYP	MAX	UNIT
SR Slew rate at unity gain	Low-to-high output	$V_O = 10\text{ V}$, $C_L = 100\text{ pF}$, $R_L = 2\text{ k}\Omega$			0.5		V/ μs
	High-to-low output				20		



LM2900, LM3900 QUADRUPLE NORTON OPERATIONAL AMPLIFIERS

SLOS059 – JULY 1979 – REVISED SEPTEMBER 1990

TYPICAL CHARACTERISTICS†

INPUT BIAS CURRENT (INVERTING INPUT)
vs
FREE-AIR TEMPERATURE

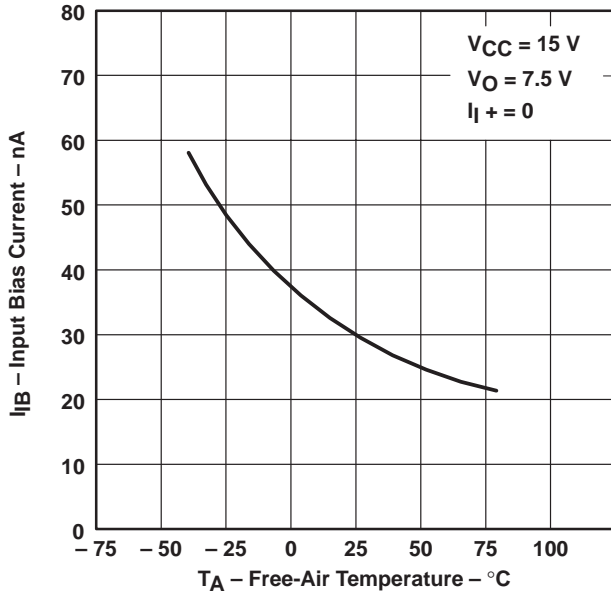

Figure 1

MIRROR GAIN
vs
FREE-AIR TEMPERATURE

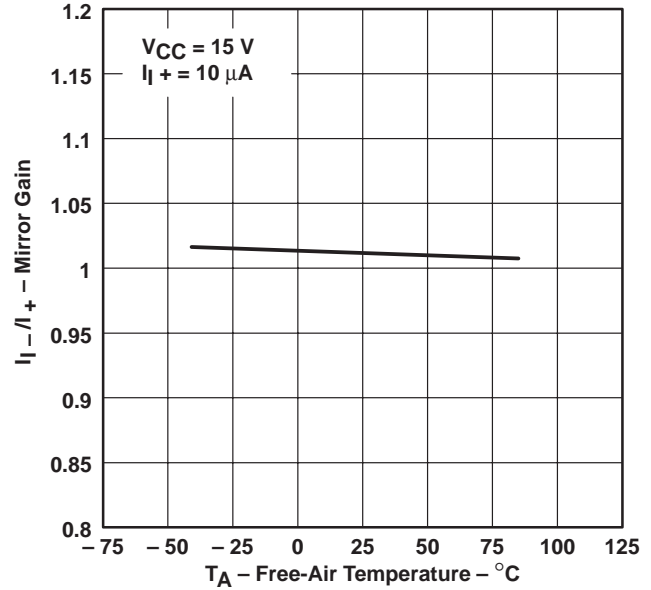

Figure 2

LARGE SIGNAL
DIFFERENTIAL VOLTAGE AMPLIFICATION
vs
FREQUENCY

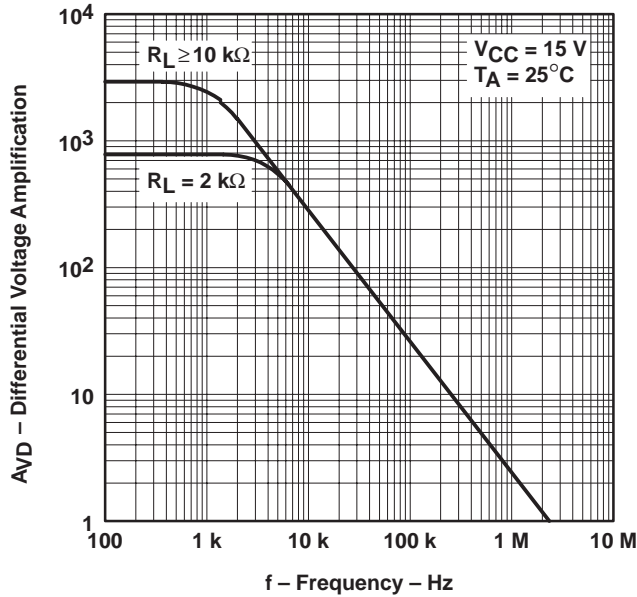

Figure 3

LARGE SIGNAL
DIFFERENTIAL VOLTAGE AMPLIFICATION
vs
SUPPLY VOLTAGE

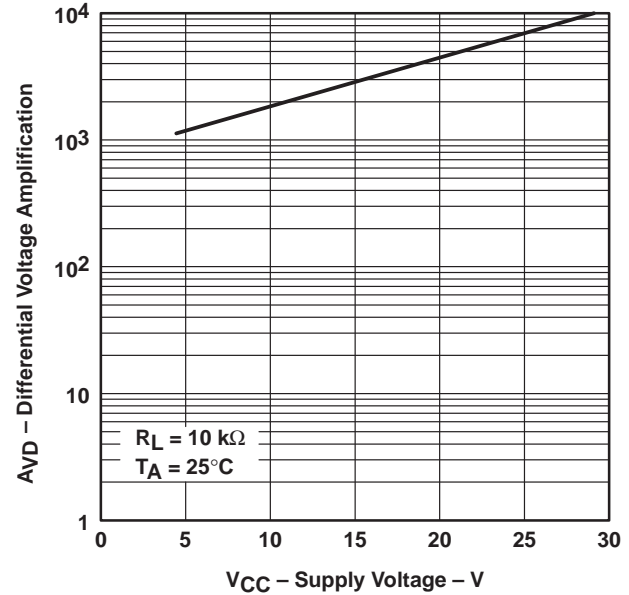
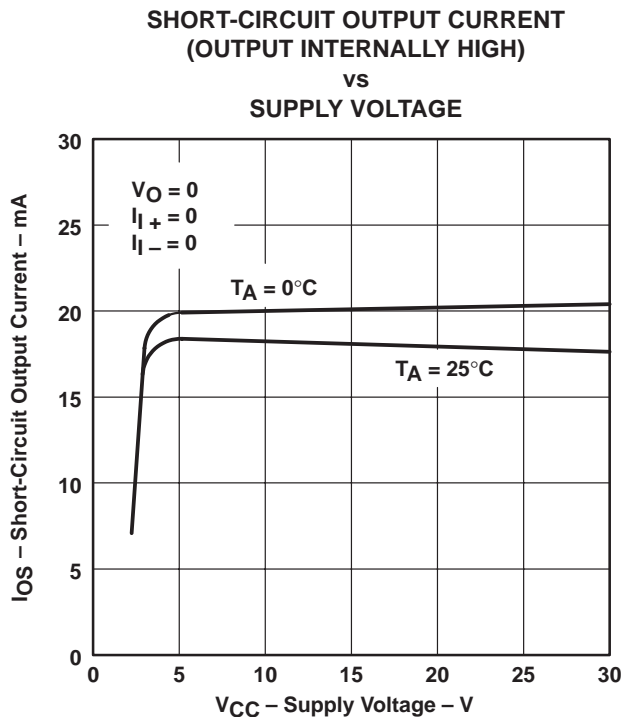
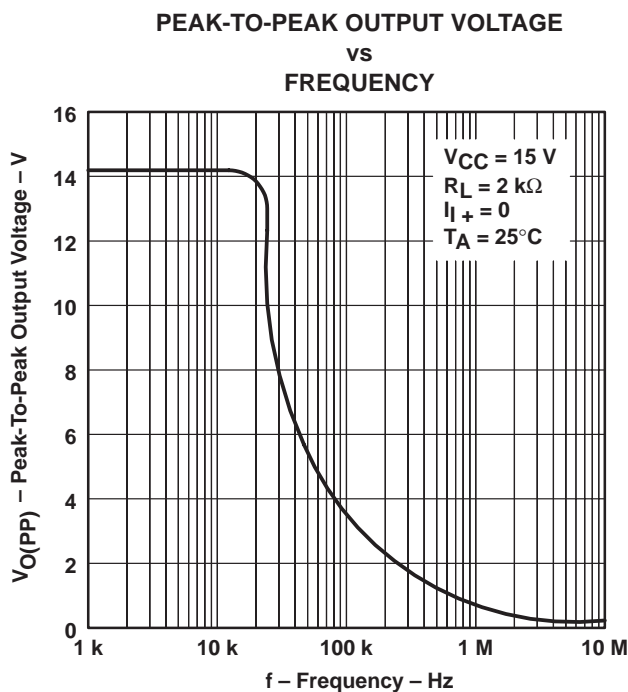
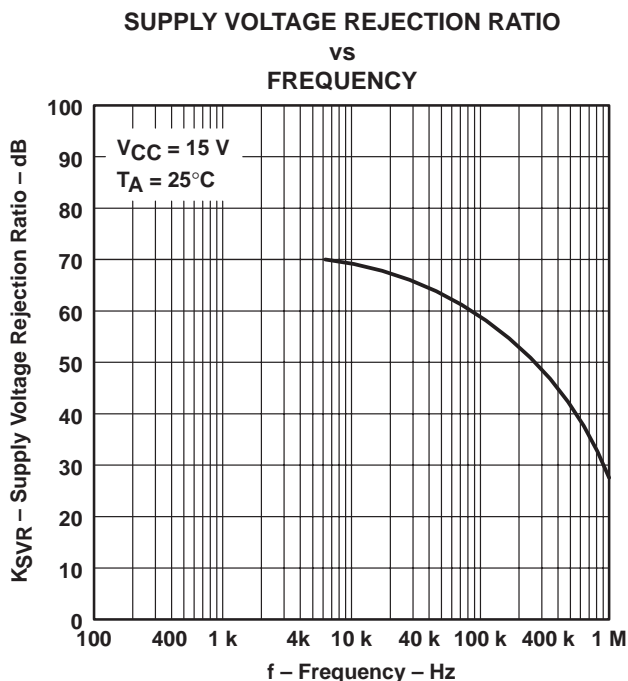
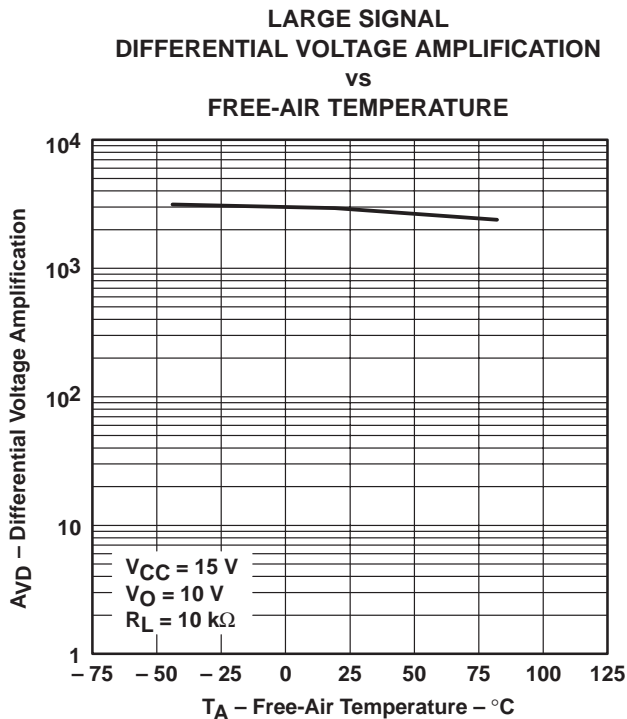

Figure 4

† Data at high and low temperatures are applicable only within the rated operating free-air temperature ranges of the various devices.

TYPICAL CHARACTERISTICS†



† Data at high and low temperatures are applicable only within the rated operating free-air temperature ranges of the various devices.

LM2900, LM3900 QUADRUPLE NORTON OPERATIONAL AMPLIFIERS

SLOS059 – JULY 1979 – REVISED SEPTEMBER 1990

TYPICAL CHARACTERISTICS†

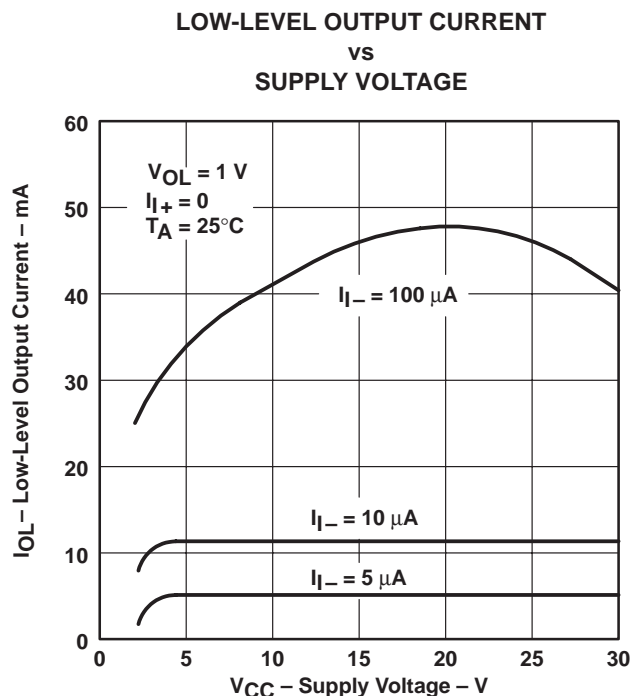

Figure 9

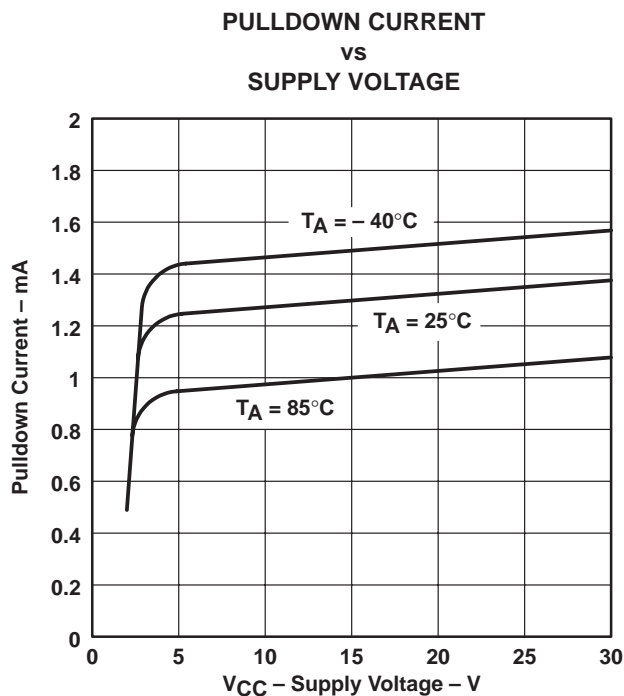

Figure 10

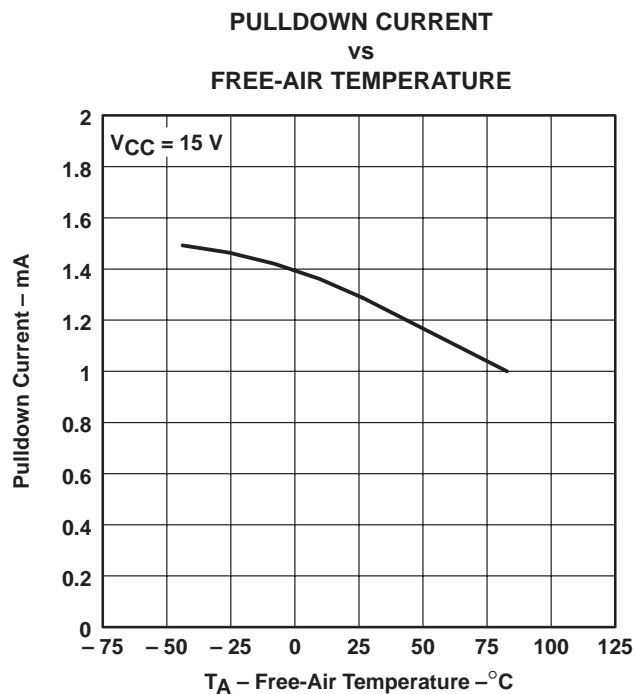

Figure 11

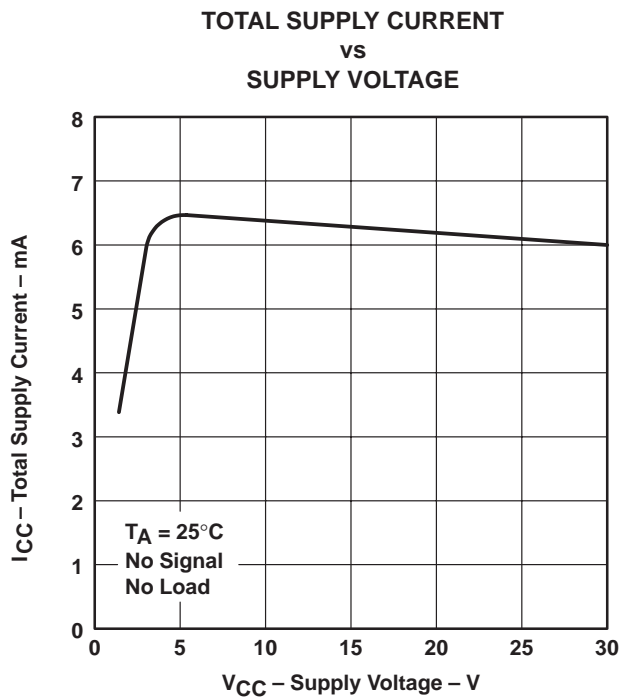

Figure 12

† Data at high and low temperatures are applicable only within the rated operating free-air temperature ranges of the various devices.



APPLICATION INFORMATION

Norton (or current-differencing) amplifiers can be used in most standard general-purpose operational amplifier applications. Performance as a dc amplifier in a single-power-supply mode is not as precise as a standard integrated-circuit operational amplifier operating from dual supplies. Operation of the amplifier can best be understood by noting that input currents are differenced at the inverting input terminal and this current then flows through the external feedback resistor to produce the output voltage. Common-mode current biasing is generally useful to allow operating with signal levels near (or even below) ground.

Internal transistors clamp negative input voltages at approximately -0.3 V but the magnitude of current flow has to be limited by the external input network. For operation at high temperature, this limit should be approximately $-100\text{ }\mu\text{A}$.

Noise immunity of a Norton amplifier is less than that of standard bipolar amplifiers. Circuit layout is more critical since coupling from the output to the noninverting input can cause oscillations. Care must also be exercised when driving either input from a low-impedance source. A limiting resistor should be placed in series with the input lead to limit the peak input current. Current up to 20 mA will not damage the device, but the current mirror on the noninverting input will saturate and cause a loss of mirror gain at higher current levels, especially at high operating temperatures.

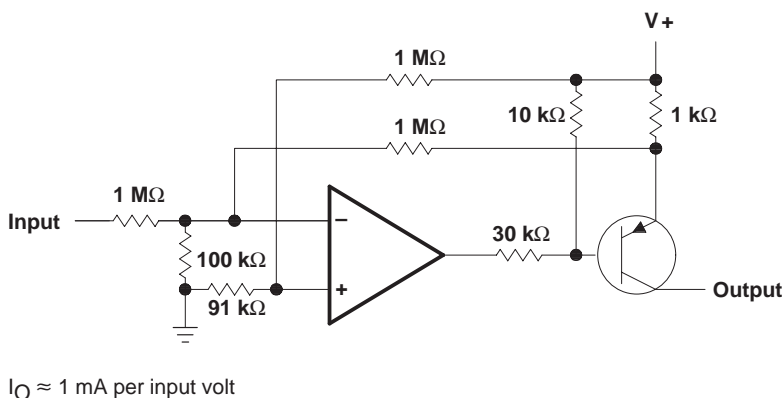

Figure 13. Voltage-Controlled Current Source

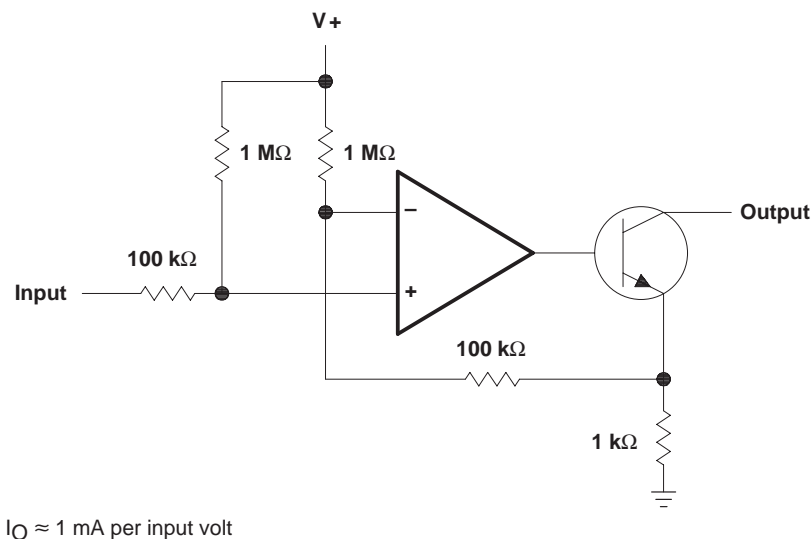

Figure 14. Voltage-Controlled Current Sink

PACKAGING INFORMATION

Orderable Device	Status ⁽¹⁾	Package Type	Package Drawing	Pins	Package Qty	Eco Plan ⁽²⁾	Lead/Ball Finish	MSL Peak Temp ⁽³⁾
LM2900D	ACTIVE	SOIC	D	14	50	Green (RoHS & no Sb/Br)	CU NIPDAU	Level-1-260C-UNLIM
LM2900DE4	ACTIVE	SOIC	D	14	50	Green (RoHS & no Sb/Br)	CU NIPDAU	Level-1-260C-UNLIM
LM2900DE4	ACTIVE	SOIC	D	14	50	Green (RoHS & no Sb/Br)	CU NIPDAU	Level-1-260C-UNLIM
LM2900DE4	ACTIVE	SOIC	D	14	50	Green (RoHS & no Sb/Br)	CU NIPDAU	Level-1-260C-UNLIM
LM2900DR	ACTIVE	SOIC	D	14	2500	Green (RoHS & no Sb/Br)	CU NIPDAU	Level-1-260C-UNLIM
LM2900DR	ACTIVE	SOIC	D	14	2500	Green (RoHS & no Sb/Br)	CU NIPDAU	Level-1-260C-UNLIM
LM2900DR	ACTIVE	SOIC	D	14	2500	Green (RoHS & no Sb/Br)	CU NIPDAU	Level-1-260C-UNLIM
LM2900DRE4	ACTIVE	SOIC	D	14	2500	Green (RoHS & no Sb/Br)	CU NIPDAU	Level-1-260C-UNLIM
LM2900DRE4	ACTIVE	SOIC	D	14	2500	Green (RoHS & no Sb/Br)	CU NIPDAU	Level-1-260C-UNLIM
LM2900DRE4	ACTIVE	SOIC	D	14	2500	Green (RoHS & no Sb/Br)	CU NIPDAU	Level-1-260C-UNLIM
LM2900N	ACTIVE	PDIP	N	14	25	Pb-Free (RoHS)	CU NIPDAU	N / A for Pkg Type
LM2900N	ACTIVE	PDIP	N	14	25	Pb-Free (RoHS)	CU NIPDAU	N / A for Pkg Type
LM2900N	ACTIVE	PDIP	N	14	25	Pb-Free (RoHS)	CU NIPDAU	N / A for Pkg Type
LM2900NE4	ACTIVE	PDIP	N	14	25	Pb-Free (RoHS)	CU NIPDAU	N / A for Pkg Type
LM2900NE4	ACTIVE	PDIP	N	14	25	Pb-Free (RoHS)	CU NIPDAU	N / A for Pkg Type
LM2900NE4	ACTIVE	PDIP	N	14	25	Pb-Free (RoHS)	CU NIPDAU	N / A for Pkg Type
LM3900D	ACTIVE	SOIC	D	14	50	Green (RoHS & no Sb/Br)	CU NIPDAU	Level-1-260C-UNLIM
LM3900D	ACTIVE	SOIC	D	14	50	Green (RoHS & no Sb/Br)	CU NIPDAU	Level-1-260C-UNLIM
LM3900D	ACTIVE	SOIC	D	14	50	Green (RoHS & no Sb/Br)	CU NIPDAU	Level-1-260C-UNLIM
LM3900DE4	ACTIVE	SOIC	D	14	50	Green (RoHS & no Sb/Br)	CU NIPDAU	Level-1-260C-UNLIM
LM3900DE4	ACTIVE	SOIC	D	14	50	Green (RoHS & no Sb/Br)	CU NIPDAU	Level-1-260C-UNLIM
LM3900DE4	ACTIVE	SOIC	D	14	50	Green (RoHS & no Sb/Br)	CU NIPDAU	Level-1-260C-UNLIM
LM3900DR	ACTIVE	SOIC	D	14	2500	Green (RoHS & no Sb/Br)	CU NIPDAU	Level-1-260C-UNLIM
LM3900DR	ACTIVE	SOIC	D	14	2500	Green (RoHS & no Sb/Br)	CU NIPDAU	Level-1-260C-UNLIM
LM3900DR	ACTIVE	SOIC	D	14	2500	Green (RoHS & no Sb/Br)	CU NIPDAU	Level-1-260C-UNLIM

Orderable Device	Status ⁽¹⁾	Package Type	Package Drawing	Pins	Package Qty	Eco Plan ⁽²⁾	Lead/Ball Finish	MSL Peak Temp ⁽³⁾
LM3900DRE4	ACTIVE	SOIC	D	14	2500	Green (RoHS & no Sb/Br)	CU NIPDAU	Level-1-260C-UNLIM
LM3900DRE4	ACTIVE	SOIC	D	14	2500	Green (RoHS & no Sb/Br)	CU NIPDAU	Level-1-260C-UNLIM
LM3900DRE4	ACTIVE	SOIC	D	14	2500	Green (RoHS & no Sb/Br)	CU NIPDAU	Level-1-260C-UNLIM
LM3900N	ACTIVE	PDIP	N	14	25	Pb-Free (RoHS)	CU NIPDAU	N / A for Pkg Type
LM3900N	ACTIVE	PDIP	N	14	25	Pb-Free (RoHS)	CU NIPDAU	N / A for Pkg Type
LM3900N	ACTIVE	PDIP	N	14	25	Pb-Free (RoHS)	CU NIPDAU	N / A for Pkg Type
LM3900NE4	ACTIVE	PDIP	N	14	25	Pb-Free (RoHS)	CU NIPDAU	N / A for Pkg Type
LM3900NE4	ACTIVE	PDIP	N	14	25	Pb-Free (RoHS)	CU NIPDAU	N / A for Pkg Type
LM3900NE4	ACTIVE	PDIP	N	14	25	Pb-Free (RoHS)	CU NIPDAU	N / A for Pkg Type

⁽¹⁾ The marketing status values are defined as follows:

ACTIVE: Product device recommended for new designs.

LIFEBUY: TI has announced that the device will be discontinued, and a lifetime-buy period is in effect.

NRND: Not recommended for new designs. Device is in production to support existing customers, but TI does not recommend using this part in a new design.

PREVIEW: Device has been announced but is not in production. Samples may or may not be available.

OBSOLETE: TI has discontinued the production of the device.

⁽²⁾ Eco Plan - The planned eco-friendly classification: Pb-Free (RoHS), Pb-Free (RoHS Exempt), or Green (RoHS & no Sb/Br) - please check <http://www.ti.com/productcontent> for the latest availability information and additional product content details.

TBD: The Pb-Free/Green conversion plan has not been defined.

Pb-Free (RoHS): TI's terms "Lead-Free" or "Pb-Free" mean semiconductor products that are compatible with the current RoHS requirements for all 6 substances, including the requirement that lead not exceed 0.1% by weight in homogeneous materials. Where designed to be soldered at high temperatures, TI Pb-Free products are suitable for use in specified lead-free processes.

Pb-Free (RoHS Exempt): This component has a RoHS exemption for either 1) lead-based flip-chip solder bumps used between the die and package, or 2) lead-based die adhesive used between the die and leadframe. The component is otherwise considered Pb-Free (RoHS compatible) as defined above.

Green (RoHS & no Sb/Br): TI defines "Green" to mean Pb-Free (RoHS compatible), and free of Bromine (Br) and Antimony (Sb) based flame retardants (Br or Sb do not exceed 0.1% by weight in homogeneous material)

⁽³⁾ MSL, Peak Temp. -- The Moisture Sensitivity Level rating according to the JEDEC industry standard classifications, and peak solder temperature.

Important Information and Disclaimer:The information provided on this page represents TI's knowledge and belief as of the date that it is provided. TI bases its knowledge and belief on information provided by third parties, and makes no representation or warranty as to the accuracy of such information. Efforts are underway to better integrate information from third parties. TI has taken and continues to take reasonable steps to provide representative and accurate information but may not have conducted destructive testing or chemical analysis on incoming materials and chemicals. TI and TI suppliers consider certain information to be proprietary, and thus CAS numbers and other limited information may not be available for release.

In no event shall TI's liability arising out of such information exceed the total purchase price of the TI part(s) at issue in this document sold by TI to Customer on an annual basis.

N (R-PDIP-T**)

PLASTIC DUAL-IN-LINE PACKAGE

16 PINS SHOWN



4040049/E 12/2002

- NOTES:
- A. All linear dimensions are in inches (millimeters).
 - B. This drawing is subject to change without notice.
 - (C) Falls within JEDEC MS-001, except 18 and 20 pin minimum body length (Dim A).
 - (D) The 20 pin end lead shoulder width is a vendor option, either half or full width.

IMPORTANT NOTICE

Texas Instruments Incorporated and its subsidiaries (TI) reserve the right to make corrections, modifications, enhancements, improvements, and other changes to its products and services at any time and to discontinue any product or service without notice. Customers should obtain the latest relevant information before placing orders and should verify that such information is current and complete. All products are sold subject to TI's terms and conditions of sale supplied at the time of order acknowledgment.

TI warrants performance of its hardware products to the specifications applicable at the time of sale in accordance with TI's standard warranty. Testing and other quality control techniques are used to the extent TI deems necessary to support this warranty. Except where mandated by government requirements, testing of all parameters of each product is not necessarily performed.

TI assumes no liability for applications assistance or customer product design. Customers are responsible for their products and applications using TI components. To minimize the risks associated with customer products and applications, customers should provide adequate design and operating safeguards.

TI does not warrant or represent that any license, either express or implied, is granted under any TI patent right, copyright, mask work right, or other TI intellectual property right relating to any combination, machine, or process in which TI products or services are used. Information published by TI regarding third-party products or services does not constitute a license from TI to use such products or services or a warranty or endorsement thereof. Use of such information may require a license from a third party under the patents or other intellectual property of the third party, or a license from TI under the patents or other intellectual property of TI.

Reproduction of information in TI data books or data sheets is permissible only if reproduction is without alteration and is accompanied by all associated warranties, conditions, limitations, and notices. Reproduction of this information with alteration is an unfair and deceptive business practice. TI is not responsible or liable for such altered documentation.

Resale of TI products or services with statements different from or beyond the parameters stated by TI for that product or service voids all express and any implied warranties for the associated TI product or service and is an unfair and deceptive business practice. TI is not responsible or liable for any such statements.

Following are URLs where you can obtain information on other Texas Instruments products and application solutions:

Products		Applications	
Amplifiers	amplifier.ti.com	Audio	www.ti.com/audio
Data Converters	dataconverter.ti.com	Automotive	www.ti.com/automotive
DSP	dsp.ti.com	Broadband	www.ti.com/broadband
Interface	interface.ti.com	Digital Control	www.ti.com/digitalcontrol
Logic	logic.ti.com	Military	www.ti.com/military
Power Mgmt	power.ti.com	Optical Networking	www.ti.com/opticalnetwork
Microcontrollers	microcontroller.ti.com	Security	www.ti.com/security
Low Power Wireless	www.ti.com/lpw	Telephony	www.ti.com/telephony
		Video & Imaging	www.ti.com/video
		Wireless	www.ti.com/wireless

Mailing Address: Texas Instruments
Post Office Box 655303 Dallas, Texas 75265

Copyright © 2006, Texas Instruments Incorporated