



One Megabit per Second Triple Digital Isolators

Check for Samples: [ISO7230A](#), [ISO7231A](#)

FEATURES

- 1Mbps Signaling Rate
 - Low Channel-to-Channel Output Skew; 2ns Maximum (5V-Operation)
 - Low Pulse-Width Distortion (PWD); 10ns Maximum (5V-Operation)
- Typical 25-Year Life at Rated Working Voltage (See Application note [SLLA197](#) and [Figure 10](#))
- 4000V_{peak} Isolation, 560V_{peak} V_{IORM}
 - UL 1577, IEC 60747-5-2 (VDE 0884, Rev 2), IE 61010-1 and CSA Approved, IEC 60950-1
- 4kV ESD Protection
- Operate With 3.3V or 5V Supplies
- High Electromagnetic Immunity (See Application note [SLLA181](#))
- –40°C to 125°C Operating Range

APPLICATIONS

- Industrial Fieldbus
- Computer Peripheral Interface
- Servo Control Interface
- Data Acquisition

DESCRIPTION

See the [Product Notification](#) section. The ISO7230A and ISO7231A are triple-channel digital isolators each with multiple channel configurations and output-enable functions. These devices have logic input and output buffers separated by TI's silicon dioxide (SiO₂) isolation barrier. Used in conjunction with isolated power supplies, these devices block high voltage, isolate grounds, and prevent noise currents on a data bus or other circuits from entering the local ground and interfering with or damaging sensitive circuitry.

The ISO7230 triple-channel device has all three channels in the same direction while the ISO7231 has two channels in one direction and one channel in opposition. These devices have an active-high output enable that when driven to a low level, places the output in a high-impedance state.

The ISO7230A and ISO7231A have TTL input thresholds and a noise-filter at the input that prevents transient pulses of up to 2ns in duration from being passed to the output of the device.

In each device a periodic update pulse is sent across the isolation barrier to ensure the proper dc level of the output. If this dc-refresh pulse is not received, the input is assumed to be unpowered or not being actively driven, and the failsafe circuit drives the output to a logic high state. (Contact TI for a logic low failsafe option).

These devices require two supply voltages of 3.3V, 5V, or any combination. All inputs are 5V tolerant when supplied from a 3.3V supply and all outputs are 4mA CMOS. These devices are characterized for operation over the ambient temperature range of –40°C to 125°C.

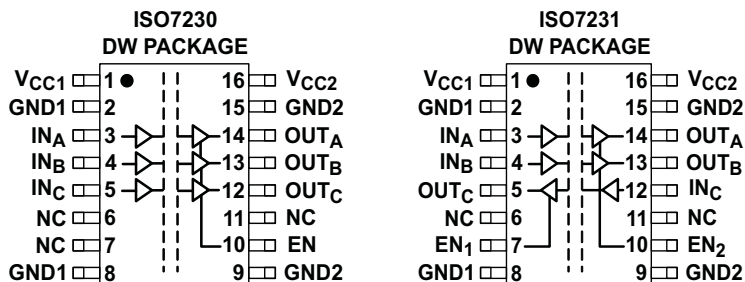

Please be aware that an important notice concerning availability, standard warranty, and use in critical applications of Texas Instruments semiconductor products and disclaimers thereto appears at the end of this data sheet.



This integrated circuit can be damaged by ESD. Texas Instruments recommends that all integrated circuits be handled with appropriate precautions. Failure to observe proper handling and installation procedures can cause damage.

ESD damage can range from subtle performance degradation to complete device failure. Precision integrated circuits may be more susceptible to damage because very small parametric changes could cause the device not to meet its published specifications.

FUNCTION DIAGRAM

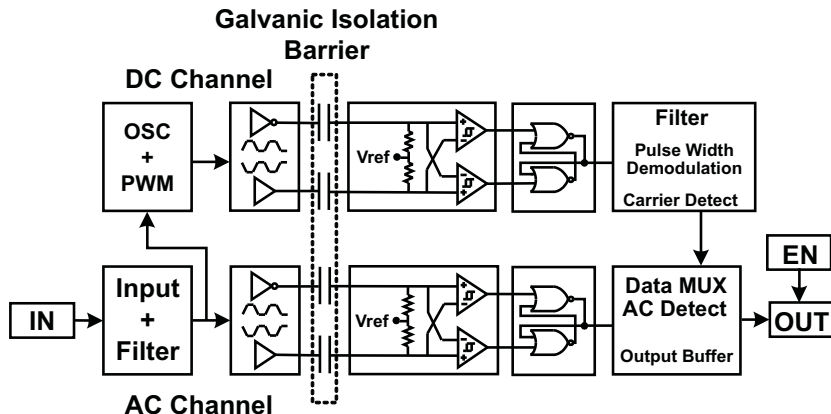

Table 1. Device Function Table ISO723x (1)

INPUT V _{CC}	OUTPUT V _{CC}	INPUT (IN)	OUTPUT ENABLE (EN)	OUTPUT (OUT)
PU	PU	H	H or Open	H
		L	H or Open	L
		X	L	Z
		Open	H or Open	H
PD	PU	X	H or Open	H
PD	PU	X	L	Z

(1) PU = Powered Up; PD = Powered Down ; X = Irrelevant; H = High Level; L = Low Level

AVAILABLE OPTIONS

PRODUCT	SIGNALING RATE	INPUT THRESHOLD	CHANNEL CONFIGURATION	MARKED AS	ORDERING NUMBER ⁽¹⁾
ISO7230ADW	1 Mbps	~1.5V (TTL) (CMOS compatible)	3/0	ISO7230A	ISO7230ADW (rail)
					ISO7230ADWR (reel)
ISO7231ADW	1 Mbps	~1.5 V (TTL) (CMOS compatible)	2/1	ISO7231A	ISO7231ADW (rail)
					ISO7231ADWR (reel)

(1) For the most current package and ordering information, see the Package Option Addendum at the end of this document, or see the TI website at www.ti.com.

ABSOLUTE MAXIMUM RATINGS⁽¹⁾

				VALUE	UNIT
V _{CC}	Supply voltage ⁽²⁾ , V _{CC1} , V _{CC2}			–0.5 to 6	V
V _I	Voltage at IN, OUT, EN			–0.5 to 6	V
I _O	Output current			±15	mA
ESD	Electrostatic discharge	Human Body Model	JEDEC Standard 22, Test Method A114-C.01	All pins	±4
		Field-Induced-Charged Device Model	JEDEC Standard 22, Test Method C101		±1
		Machine Model	ANSI/ESDS5.2-1996		±200
T _J	Maximum junction temperature			170	°C

- (1) Stresses beyond those listed under *absolute maximum ratings* may cause permanent damage to the device. These are stress ratings only and functional operation of the device at these or any other conditions beyond those indicated under *recommended operating conditions* is not implied. Exposure to absolute-maximum-rated conditions for extended periods may affect device reliability.
- (2) All voltage values are with respect to network ground terminal and are peak voltage values.

RECOMMENDED OPERATING CONDITIONS

		MIN	TYP	MAX	UNIT
V _{CC}	Supply voltage ⁽¹⁾ , V _{CC1} , V _{CC2}	3.15		5.5	V
I _{OH}	High-level output current	–4			mA
I _{OL}	Low-level output current			4	mA
t _{ui}	Input pulse width	1			µs
1/t _{ui}	Signaling rate	0	1500 ⁽²⁾	1000	kbps
V _{IH}	High-level input voltage (IN) (EN on all devices)	2		V _{CC}	V
V _{IL}	Low-level input voltage (IN) (EN on all devices)	0		0.8	V
T _J	Junction temperature			150	°C
H	External magnetic field-strength immunity per IEC 61000-4-8 and IEC 61000-4-9 certification			1000	A/m

- (1) For the 5V operation, V_{CC1} or V_{CC2} is specified from 4.5V to 5.5V.
For the 3V operation, V_{CC1} or V_{CC2} is specified from 3.15V to 3.6V.
- (2) Typical signaling rate under ideal conditions at 25°C.

ISO7230A
ISO7231A

SLLS906C –MAY 2008–REVISED JUNE 2011

www.ti.com

ELECTRICAL CHARACTERISTICS: V_{CC1} and V_{CC2} at 5V⁽¹⁾ OPERATION

over recommended operating conditions (unless otherwise noted)

PARAMETER		TEST CONDITIONS		MIN	TYP	MAX	UNIT
SUPPLY CURRENT							
I_{CC1}	ISO7230A	Quiescent	$V_I = V_{CC}$ or 0V, All channels, no load, EN_2 at 3V		1	3	mA
		1 Mbps			1	3	
	ISO7231A	Quiescent	$V_I = V_{CC}$ or 0V, All channels, no load, EN_1 at 3V, EN_2 at 3V		6.5	11	mA
		1 Mbps			6.5	11	
I_{CC2}	ISO7230A	Quiescent	$V_I = V_{CC}$ or 0V, All channels, no load, EN_2 at 3V		15	22	mA
		1 Mbps			16	22	
	ISO7231A	Quiescent	$V_I = V_{CC}$ or 0V, All channels, no load, EN_1 at 3V, EN_2 at 3V		13	20	mA
		1 Mbps			13	20	
ELECTRICAL CHARACTERISTICS							
I_{OFF}	Sleep mode output current	EN at 0V, Single channel			0		μ A
V_{OH}	High-level output voltage	$I_{OH} = -4$ mA, See Figure 1		$V_{CC} - 0.8$			V
		$I_{OH} = -20$ μ A, See Figure 1		$V_{CC} - 0.1$			
V_{OL}	Low-level output voltage	$I_{OL} = 4$ mA, See Figure 1				0.4	V
		$I_{OL} = 20$ μ A, See Figure 1				0.1	
$V_{I(HYS)}$	Input voltage hysteresis				150		mV
I_{IH}	High-level input current	IN from 0V to V_{CC}				10	μ A
I_{IL}	Low-level input current					-10	
C_I	Input capacitance to ground	IN at V_{CC} , $V_I = 0.4 \sin(4E6\pi t)$			2		pF
CMTI	Common-mode transient immunity	$V_I = V_{CC}$ or 0V, See Figure 4		25	50		kV/ μ s

- (1) For the 5V operation, V_{CC1} or V_{CC2} is specified from 4.5V to 5.5V.
For the 3V operation, V_{CC1} or V_{CC2} is specified from 3.15V to 3.6V.

SWITCHING CHARACTERISTICS: V_{CC1} and V_{CC2} at 5V OPERATION

over recommended operating conditions (unless otherwise noted)

PARAMETER		TEST CONDITIONS	MIN	TYP	MAX	UNIT
t_{PLH} , t_{PHL}	Propagation delay	See Figure 1	40		95	ns
PWD	Pulse-width distortion ⁽¹⁾ $ t_{PHL} - t_{PLH} $				10	
$t_{sk(o)}$	Channel-to-channel output skew ⁽²⁾			0	2	ns
t_r	Output signal rise time	See Figure 1		2		ns
t_f	Output signal fall time			2		
t_{PHZ}	Propagation delay, high-level-to-high-impedance output	See Figure 2		15	20	ns
t_{PZH}	Propagation delay, high-impedance-to-high-level output			15	20	
t_{PLZ}	Propagation delay, low-level-to-high-impedance output			15	20	
t_{PZL}	Propagation delay, high-impedance-to-low-level output			15	20	
t_{fs}	Failsafe output delay time from input power loss	See Figure 3		12		μ s

- (1) Also referred to as pulse skew.
(2) $t_{sk(o)}$ is the skew between specified outputs of a single device with all driving inputs connected together and the outputs switching in the same direction while driving identical specified loads.

ELECTRICAL CHARACTERISTICS: V_{CC1} at 5V, V_{CC2} at 3.3V⁽¹⁾ OPERATION

over recommended operating conditions (unless otherwise noted)

PARAMETER		TEST CONDITIONS		MIN	TYP	MAX	UNIT
SUPPLY CURRENT							
I_{CC1}	ISO7230A	Quiescent	$V_I = V_{CC}$ or 0V, All channels, no load, EN ₂ at 3V		1	3	mA
		1 Mbps			1	3	
	ISO7231A	Quiescent	$V_I = V_{CC}$ or 0V, All channels, no load, EN ₁ at 3V, EN ₂ at 3V		6.5	11	mA
		1 Mbps			6.5	11	
I_{CC2}	ISO7230A	Quiescent	$V_I = V_{CC}$ or 0V, All channels, no load, EN ₂ at 3V		9	15	mA
		1 Mbps			9.5	15	
	ISO7231A	Quiescent	$V_I = V_{CC}$ or 0V, All channels, no load, EN ₁ at 3V, EN ₂ at 3V		8	12	mA
		1 Mbps			8	12	
ELECTRICAL CHARACTERISTICS							
I_{OFF}	Sleep mode output current	EN at 0 V, Single channel			0		μA
V_{OH}	High-level output voltage	$I_{OH} = -4\text{mA}$, See Figure 1	ISO7230	$V_{CC} - 0.4$		V	
			ISO7231 (5-V side)	$V_{CC} - 0.8$			
		$I_{OH} = -20\mu\text{A}$, See Figure 1		$V_{CC} - 0.1$			
V_{OL}	Low-level output voltage	$I_{OL} = 4\text{mA}$, See Figure 1		0.4		V	
		$I_{OL} = 20\mu\text{A}$, See Figure 1		0.1			
$V_{I(HYS)}$	Input voltage hysteresis			150		mV	
I_{IH}	High-level input current	IN from 0V to V_{CC}		10		μA	
I_{IL}	Low-level input current			-10			
C_I	Input capacitance to ground	IN at V_{CC} , $V_I = 0.4 \sin(4E6\pi t)$		2		pF	
CMTI	Common-mode transient immunity	$V_I = V_{CC}$ or 0 V, See Figure 4		25	50	kV/μs	

- (1) For the 5-V operation, V_{CC1} or V_{CC2} is specified from 4.5V to 5.5V.
For the 3V operation, V_{CC1} or V_{CC2} is specified from 3.15 V to 3.6 V.

SWITCHING CHARACTERISTICS: V_{CC1} at 5V, V_{CC2} at 3.3V OPERATION

over recommended operating conditions (unless otherwise noted)

PARAMETER		TEST CONDITIONS	MIN	TYP	MAX	UNIT
t_{PLH} , t_{PHL}	Propagation delay, low-to-high-level output	See Figure 1	40		100	ns
PWD	Pulse-width distortion ⁽¹⁾ $ t_{PHL} - t_{PLH} $				11	
$t_{sk(o)}$	Channel-to-channel output skew ⁽²⁾	ISO723xA		0	2.5	ns
t_r	Output signal rise time	See Figure 1			2	ns
t_f	Output signal fall time				2	
t_{PHZ}	Propagation delay, high-level-to-high-impedance output	See Figure 2			15	ns
t_{PZH}	Propagation delay, high-impedance-to-high-level output				15	
t_{PLZ}	Propagation delay, low-level-to-high-impedance output				15	
t_{PZL}	Propagation delay, high-impedance-to-low-level output				15	
t_{fs}	Failsafe output delay time from input power loss	See Figure 3			18	μs

- (1) Also known as pulse skew
(2) $t_{sk(o)}$ is the skew between specified outputs of a single device with all driving inputs connected together and the outputs switching in the same direction while driving identical specified loads.

ISO7230A
ISO7231A

SLLS906C –MAY 2008–REVISED JUNE 2011

www.ti.com

ELECTRICAL CHARACTERISTICS: V_{CC1} at 3.3V, V_{CC2} at 5V⁽¹⁾ OPERATION

over recommended operating conditions (unless otherwise noted)

PARAMETER		TEST CONDITIONS		MIN	TYP	MAX	UNIT	
SUPPLY CURRENT								
I_{CC1}	ISO7230A	Quiescent	$V_I = V_{CC}$ or 0V, All channels, no load, EN ₂ at 3V	0.5	1	1	mA	
		1 Mbps						
	ISO7231A	Quiescent		4.5	7	7		mA
		1 Mbps						
I_{CC2}	ISO7230A	Quiescent	$V_I = V_{CC}$ or 0V, All channels, no load, EN ₂ at 3V	15	22	22	mA	
		1 Mbps						
	ISO7231A	Quiescent		13	20	20		mA
		1 Mbps						
ELECTRICAL CHARACTERISTICS								
I_{OFF}	Sleep mode output current	EN at 0V, Single channel		0			μA	
V_{OH}	High-level output voltage	$I_{OH} = -4\text{mA}$, See Figure 1	ISO7230	$V_{CC} - 0.4$		V		
			ISO7231 (5-V side)	$V_{CC} - 0.8$				
		$I_{OH} = -20\mu\text{A}$, See Figure 1	$V_{CC} - 0.1$					
V_{OL}	Low-level output voltage	$I_{OL} = 4\text{mA}$, See Figure 1		0.4		V		
		$I_{OL} = 20\mu\text{A}$, See Figure 1		0.1				
$V_{I(HYS)}$	Input voltage hysteresis			150		mV		
I_{IH}	High-level input current	IN from 0V to V_{CC}		10		μA		
I_{IL}	Low-level input current							
C_I	Input capacitance to ground	IN at V_{CC} , $V_I = 0.4 \sin(4E6\pi t)$		2		pF		
CMTI	Common-mode transient immunity	$V_I = V_{CC}$ or 0V, See Figure 4		25	50	kV/μs		

- (1) For 5V operation, V_{CC1} or V_{CC2} is specified from 4.5V to 5.5V.
For 3V operation, V_{CC1} or V_{CC2} is specified from 3.15V to 3.6V.

SWITCHING CHARACTERISTICS: V_{CC1} at 3.3V and V_{CC2} at 5V OPERATION

over recommended operating conditions (unless otherwise noted)

PARAMETER		TEST CONDITIONS		MIN	TYP	MAX	UNIT
t_{PLH}, t_{PHL}	Propagation delay	ISO723xA	See Figure 1	40	100	11	ns
PWD	Pulse-width distortion ⁽¹⁾ $ t_{PHL} - t_{PLH} $						
$t_{sk(o)}$	Channel-to-channel output skew ⁽²⁾	ISO723xA		0	2.5		ns
t_r	Output signal rise time	See Figure 1		2		2	ns
t_f	Output signal fall time						
t_{PHZ}	Propagation delay, high-level-to-high-impedance output	See Figure 2		15		20	
t_{PZH}	Propagation delay, high-impedance-to-high-level output						
t_{PLZ}	Propagation delay, low-level-to-high-impedance output						
t_{PZL}	Propagation delay, high-impedance-to-low-level output						
t_{fs}	Failsafe output delay time from input power loss	See Figure 3		12			μs

- (1) Also known as pulse skew
(2) $t_{sk(o)}$ is the skew between specified outputs of a single device with all driving inputs connected together and the outputs switching in the same direction while driving identical specified loads.

ELECTRICAL CHARACTERISTICS: V_{CC1} and V_{CC2} at 3.3V⁽¹⁾ OPERATION

over recommended operating conditions (unless otherwise noted)

PARAMETER		TEST CONDITIONS		MIN	TYP	MAX	UNIT
SUPPLY CURRENT							
I_{CC1}	ISO7230A	Quiescent	$V_I = V_{CC}$ or 0 V, all channels, no load, EN_2 at 3V	0.5	1		mA
		1 Mbps		1	2		
	ISO7231A	Quiescent	$V_I = V_{CC}$ or 0V, all channels, no load, EN_1 at 3V, EN_2 at 3V	4.5	7		mA
		1 Mbps		4.5	7		
I_{CC2}	ISO7230A	Quiescent	$V_I = V_{CC}$ or 0V, all channels, no load, EN_2 at 3V	9	15		mA
		1 Mbps		9.5	15		
	ISO7231A	Quiescent	$V_I = V_{CC}$ or 0V, all channels, no load, EN_1 at 3V, EN_2 at 3V	8	12		mA
		1 Mbps		8	12		
ELECTRICAL CHARACTERISTICS							
I_{OFF}	Sleep mode output current	EN at 0V, single channel		0			μ A
V_{OH}	High-level output voltage	$I_{OH} = -4$ mA, See Figure 1		$V_{CC} - 0.4$			V
		$I_{OH} = -20$ μ A, See Figure 1		$V_{CC} - 0.1$			
V_{OL}	Low-level output voltage	$I_{OL} = 4$ mA, See Figure 1				0.4	V
		$I_{OL} = 20$ μ A, See Figure 1				0.1	
$V_{I(HYS)}$	Input voltage hysteresis			150			mV
I_{IH}	High-level input current	IN from 0V or V_{CC}			10		μ A
I_{IL}	Low-level input current			-10			
C_I	Input capacitance to ground	IN at V_{CC} , $V_I = 0.4 \sin(4E6\pi t)$			2		pF
CMTI	Common-mode transient immunity	$V_I = V_{CC}$ or 0V, See Figure 4		25	50		kV/ μ s

- (1) For 5V operation, V_{CC1} or V_{CC2} is specified from 4.5V to 5.5V.
For 3V operation, V_{CC1} or V_{CC2} is specified from 3.15V to 3.6V.

SWITCHING CHARACTERISTICS: V_{CC1} and V_{CC2} at 3.3-V OPERATION

over recommended operating conditions (unless otherwise noted)

PARAMETER		TEST CONDITIONS		MIN	TYP	MAX	UNIT
t_{PLH} , t_{PHL}	Propagation delay	ISO723xA	See Figure 1	45		110	ns
PWD	Pulse-width distortion ⁽¹⁾ $ t_{PHL} - t_{PLH} $				12		
$t_{sk(o)}$	Channel-to-channel output skew ⁽²⁾	ISO723xA			0	3	ns
t_r	Output signal rise time	See Figure 1			2		ns
t_f	Output signal fall time				2		
t_{PHZ}	Propagation delay, high-level-to-high-impedance output	See Figure 2			15	20	ns
t_{PZH}	Propagation delay, high-impedance-to-high-level output				15	20	
t_{PLZ}	Propagation delay, low-level-to-high-impedance output				15	20	
t_{PZL}	Propagation delay, high-impedance-to-low-level output				15	20	
t_{fs}	Failsafe output delay time from input power loss	See Figure 3			18		μ s

- (1) Also referred to as pulse skew.
(2) $t_{sk(o)}$ is the skew between specified outputs of a single device with all driving inputs connected together and the outputs switching in the same direction while driving identical specified loads.

PARAMETER MEASUREMENT INFORMATION

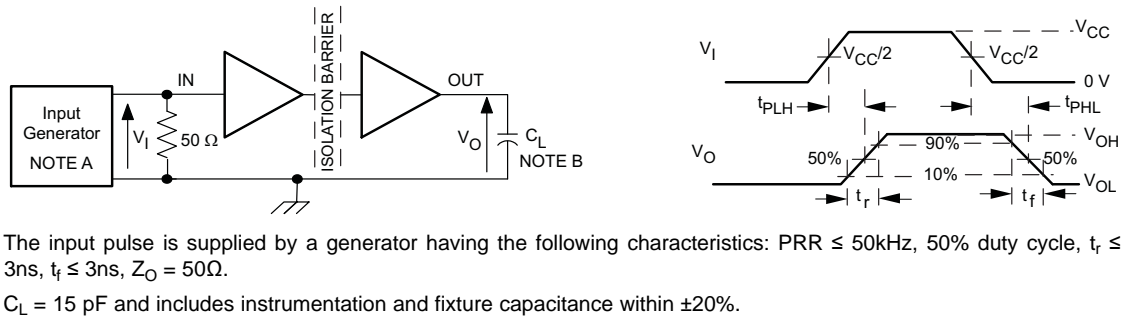

Figure 1. Switching Characteristic Test Circuit and Voltage Waveforms

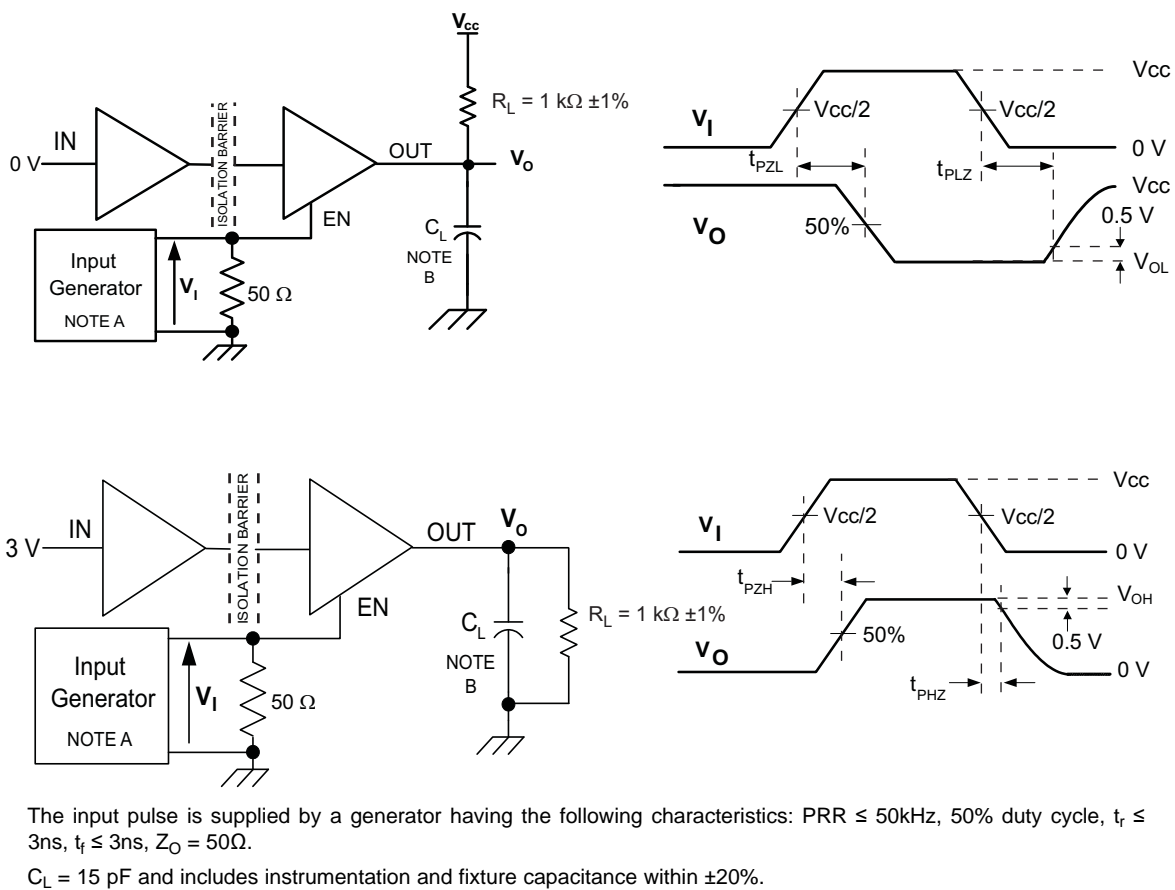
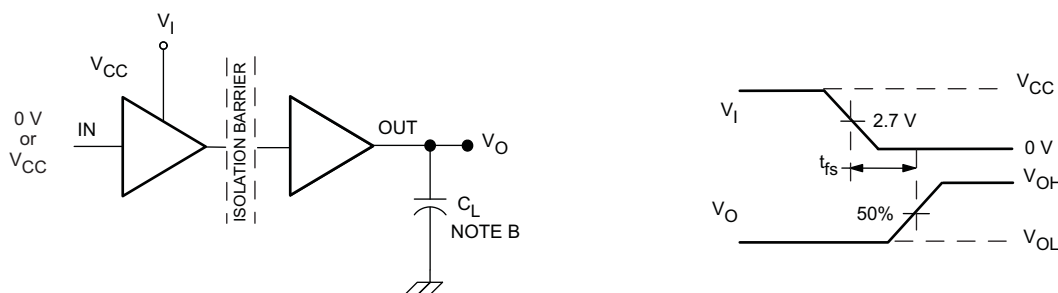

Figure 2. Enable/Disable Propagation Delay Time Test Circuit and Waveform

PARAMETER MEASUREMENT INFORMATION (continued)



- A. The input pulse is supplied by a generator having the following characteristics: PRR \leq 50kHz, 50% duty cycle, $t_r \leq$ 3ns, $t_f \leq$ 3ns, $Z_O = 50\Omega$.
- B. $C_L = 15\text{pF}$ and includes instrumentation and fixture capacitance within $\pm 20\%$.

Figure 3. Failsafe Delay Time Test Circuit and Voltage Waveforms

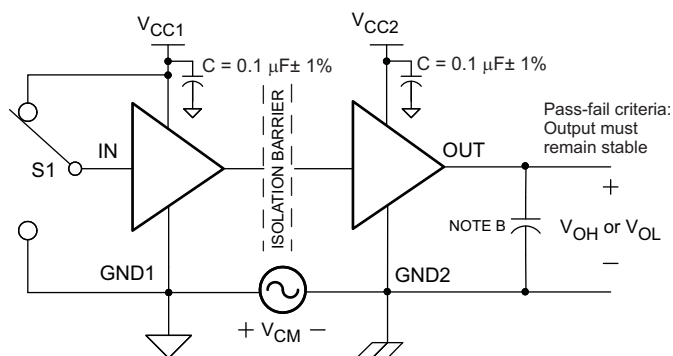

- A. The input pulse is supplied by a generator having the following characteristics: PRR \leq 50kHz, 50% duty cycle, $t_r \leq$ 3ns, $t_f \leq$ 3ns, $Z_O = 50\Omega$.
- B. $C_L = 15\text{pF}$ and includes instrumentation and fixture capacitance within $\pm 20\%$.

Figure 4. Common-Mode Transient Immunity Test Circuit and Voltage Waveform

DEVICE INFORMATION

PACKAGE CHARACTERISTICS

PARAMETER	TEST CONDITIONS	MIN	TYP	MAX	UNIT
L(I01) Minimum air gap (Clearance)	Shortest terminal-to-terminal distance through air	8.34			mm
L(I02) Minimum external tracking (Creepage)	Shortest terminal-to-terminal distance across the package surface	8.1			mm
Minimum Internal Gap (Internal Clearance)	Distance through the insulation	0.008			mm
R _{IO} Isolation resistance	Input to output, V _{IO} = 500V, all pins on each side of the barrier tied together creating a two-terminal device, T _A < 100°C		>10 ¹²		Ω
	Input to output, V _{IO} = 500V, 100°C ≤ T _A ≤ T _A max		>10 ¹¹		Ω
C _{IO} Barrier capacitance Input to output	V _I = 0.4 sin (4E6πt)		2		pF
C _I Input capacitance to ground	V _I = 0.4 sin (4E6πt)		2		pF

REGULATORY INFORMATION

VDE	CSA	UL
Certified according to IEC 60747-5-2	Approved under CSA Component Acceptance Notice	Recognized under 1577 Component Recognition Program ⁽¹⁾
File Number: 40016131	File Number: 220991	File Number: E181974

(1) Production tested ≥ 3000 VRMS for 1 second in accordance with UL 1577.

DEVICE I/O SCHEMATICS

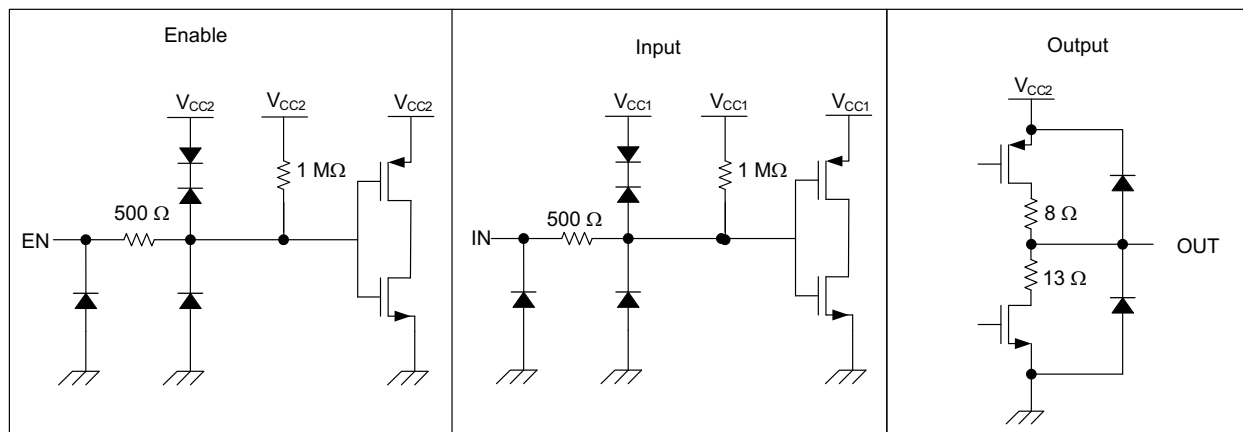

THERMAL CHARACTERISTICS

over recommended operating conditions (unless otherwise noted)

PARAMETER		TEST CONDITIONS	MIN	TYP	MAX	UNIT
θ_{JA}	Junction-to-air	Low-K Thermal Resistance ⁽¹⁾		168		°C/W
		High-K Thermal Resistance		96.1		
θ_{JB}	Junction-to-Board Thermal Resistance			61		°C/W
θ_{JC}	Junction-to-Case Thermal Resistance			48		°C/W
P_D	Device Power Dissipation	$V_{CC1} = V_{CC2} = 5.5\text{ V}$, $T_J = 150^\circ\text{C}$, $C_L = 15\text{ pF}$, Input a 50% duty cycle square wave			220	mW

(1) Tested in accordance with the Low-K or High-K thermal metric definitions of EIA/JESD51-3 for leaded surface mount packages.

TYPICAL CHARACTERISTIC CURVES

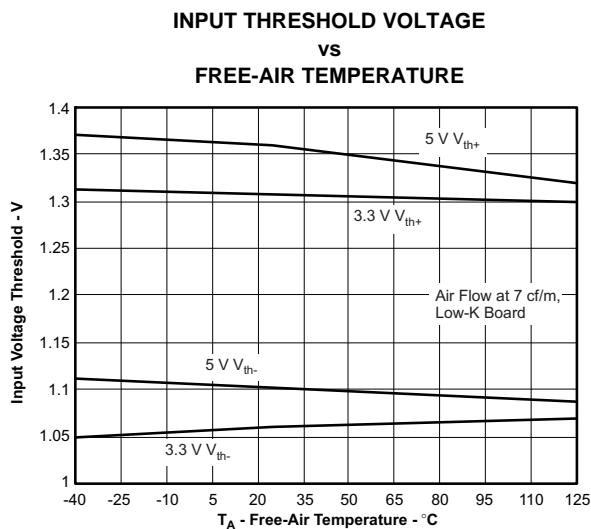

Figure 5.

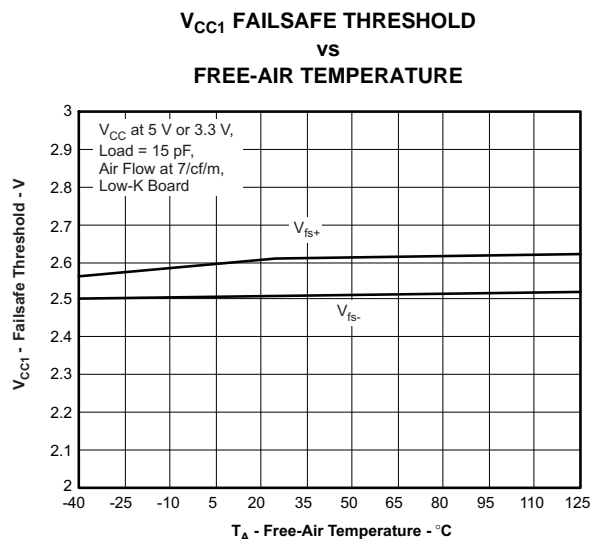

Figure 6.

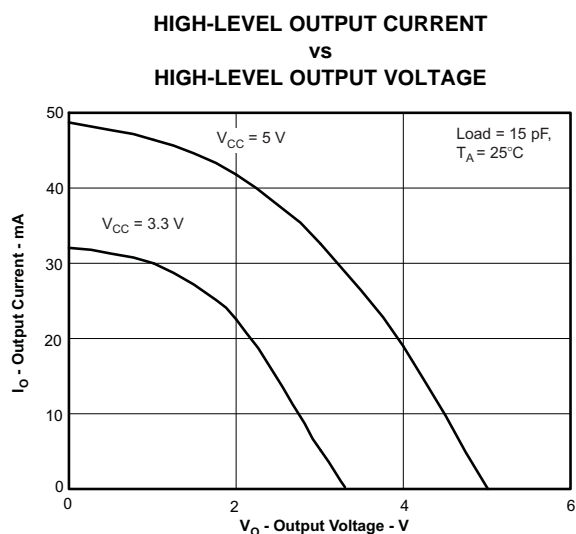

Figure 7.

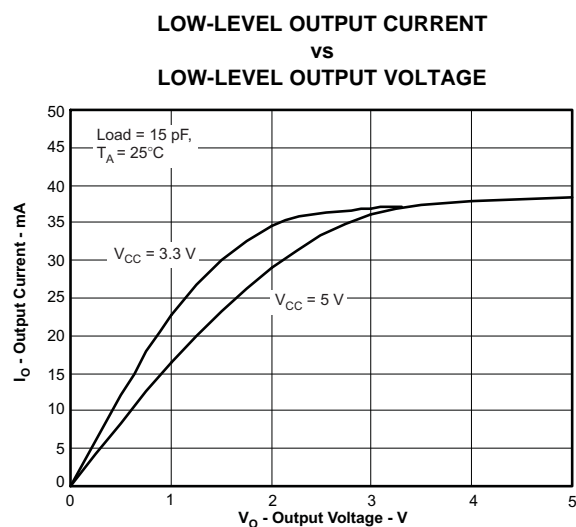

Figure 8.

APPLICATION INFORMATION

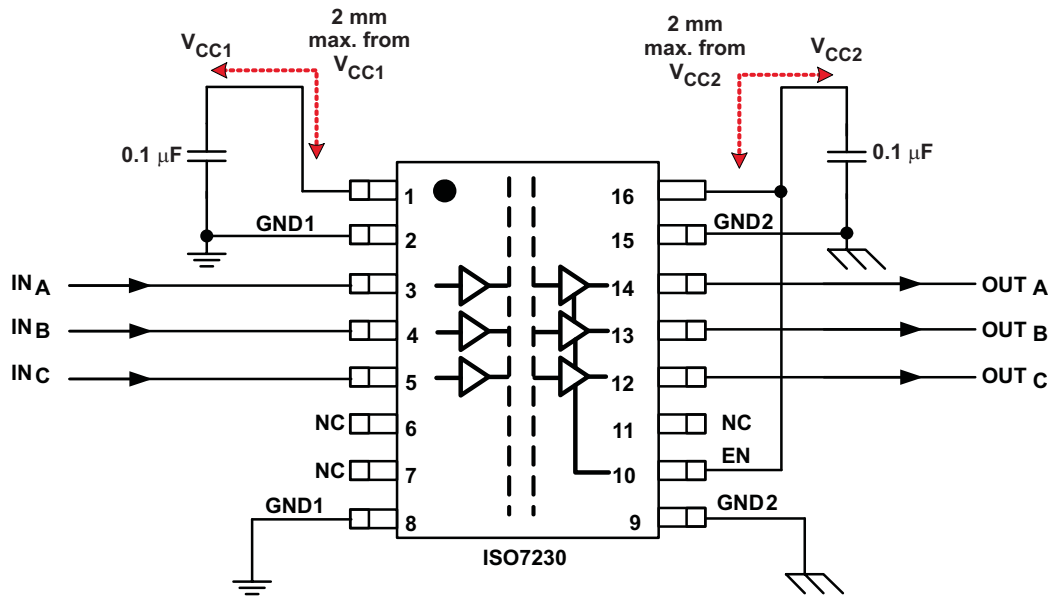

Figure 9. Typical ISO7230 Application Circuit

LIFE EXPECTANCY vs WORKING VOLTAGE

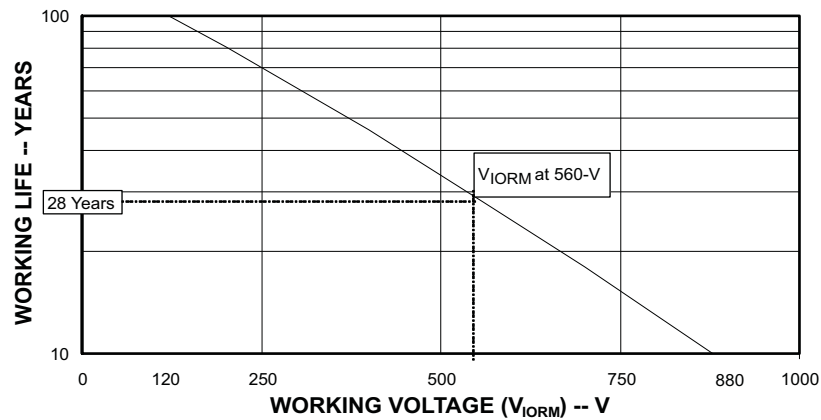

Figure 10. Time Dependant Dielectric Breakdown Testing Results

PRODUCT NOTIFICATION

An ISO723xA anomaly occurs when a negative-going pulse below the specified 1µs minimum bit width is input to the device. The output locks in a logic-low condition until the next rising edge occurs after a 1µs period.

Positive noise edges in pulses of less than the minimum specified 1µs have no effect on the device, and are properly filtered.

To prevent noise from interfering with ISO723xA performance, it is recommended that an appropriately sized capacitor be placed on each input of the device

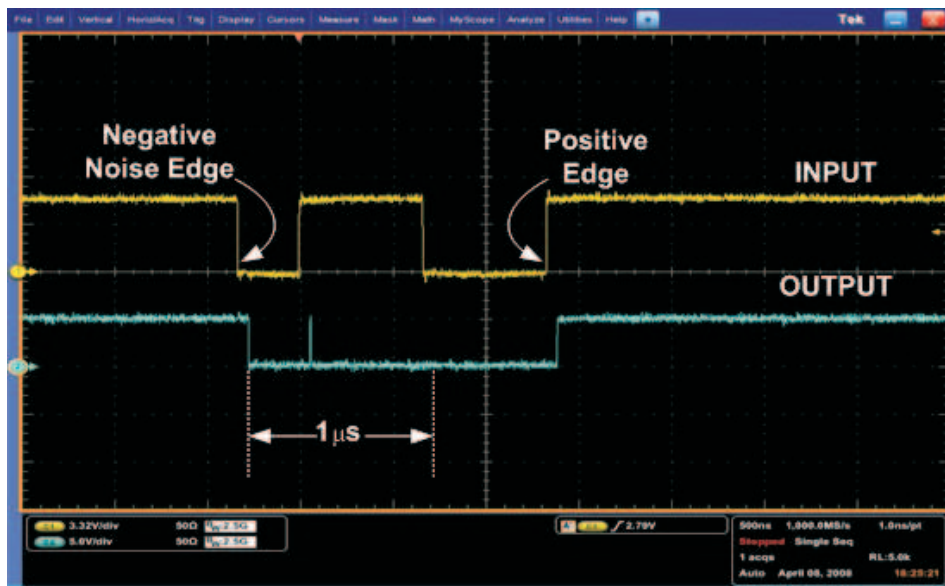

Figure 11. ISO723xA Anomaly

REVISION HISTORY

Changes from Original (May 2008) to Revision A	Page
• Added Product Notification section link.	1
• Deleted text from paragraph 2 of the Description: "and turns off internal bias circuitry to conserve power"	1
• Deleted Product Preview note	2
• Changed From: 3 To: 3.15	3
• Changed V_{CC} From: 3.6 To: 3.45	3
• Changed I_{CC1} and I_{CC2} values From: TBD	4
• Changed $V_{CC} - 0.4$ To: $V_{CC} - 0.8$	4
• Changed Typical value from 1 To: 2	4
• Changed Propagation delay max From: 80 To: 95	4
• Changed I_{CC1} and I_{CC2} values From: TBD	5
• Changed Typical value from 1 To: 2	5
• Changed Propagation delay max From: 80 To: 100	5
• Changed I_{CC1} and I_{CC2} values From: TBD	6
• Changed Typical value from 1 To: 2	6
• Changed Propagation delay max From: 80 To: 100	6
• Changed I_{CC1} and I_{CC2} values From: TBD	7
• Changed	7
• Changed Typical value from 1 To: 2	7
• Changed Propagation delay max From: 85 To: 110	7
• Changed L(101) Minimum air gap (Clearance) - minimum value from: 7.7mm to: 8.34mm	10
• Changed Typical value from 1 To: 2	10
• Changed Typical value from 1 To: 2	10
• Changed the REGULATORY INFORMATION Table	10
• Changed Figure 11	13

Changes from Revision A (June 2008) to Revision B	Page
• Changed V_{CC} From: 3.45 To: 3.6	3

Changes from Revision B (July 2008) to Revision C	Page
• Changed "1ns" to "2ns", added "(5v-Operation)"	1
• Changed "2ns" to "10ns", added "(5v-Operation)"	1
• Deleted "Low Jitter Content; 1 ns Typ at 150 Mbps"	1
• Deleted Min = 4.5 V and max = 5.5 V for Supply Voltage of the ROC Table.	3
• Changed V_{CC} From: 3.6 To: 5.5	3
• Corrected Figure 1	8
• Changed File number "1698195" to "220991"	10
• Corrected DEVICE I/O SCHEMATICS	10
• Corrected Figure 9	12

PACKAGING INFORMATION

Orderable Device	Status ⁽¹⁾	Package Type	Package Drawing	Pins	Package Qty	Eco Plan ⁽²⁾	Lead/ Ball Finish	MSL Peak Temp ⁽³⁾	Samples (Requires Login)
ISO7230ADW	NRND	SOIC	DW	16	40	Green (RoHS & no Sb/Br)	CU NIPDAU	Level-3-260C-168 HR	
ISO7230ADWG4	NRND	SOIC	DW	16	40	Green (RoHS & no Sb/Br)	CU NIPDAU	Level-3-260C-168 HR	
ISO7230ADWR	NRND	SOIC	DW	16	2000	Green (RoHS & no Sb/Br)	CU NIPDAU	Level-3-260C-168 HR	
ISO7230ADWRG4	NRND	SOIC	DW	16	2000	Green (RoHS & no Sb/Br)	CU NIPDAU	Level-3-260C-168 HR	
ISO7231ADW	NRND	SOIC	DW	16	40	Green (RoHS & no Sb/Br)	CU NIPDAU	Level-3-260C-168 HR	
ISO7231ADWG4	NRND	SOIC	DW	16	40	Green (RoHS & no Sb/Br)	CU NIPDAU	Level-3-260C-168 HR	
ISO7231ADWR	NRND	SOIC	DW	16	2000	Green (RoHS & no Sb/Br)	CU NIPDAU	Level-3-260C-168 HR	
ISO7231ADWRG4	NRND	SOIC	DW	16	2000	Green (RoHS & no Sb/Br)	CU NIPDAU	Level-3-260C-168 HR	

⁽¹⁾ The marketing status values are defined as follows:

ACTIVE: Product device recommended for new designs.

LIFEBUY: TI has announced that the device will be discontinued, and a lifetime-buy period is in effect.

NRND: Not recommended for new designs. Device is in production to support existing customers, but TI does not recommend using this part in a new design.

PREVIEW: Device has been announced but is not in production. Samples may or may not be available.

OBSOLETE: TI has discontinued the production of the device.

⁽²⁾ Eco Plan - The planned eco-friendly classification: Pb-Free (RoHS), Pb-Free (RoHS Exempt), or Green (RoHS & no Sb/Br) - please check <http://www.ti.com/productcontent> for the latest availability information and additional product content details.

TBD: The Pb-Free/Green conversion plan has not been defined.

Pb-Free (RoHS): TI's terms "Lead-Free" or "Pb-Free" mean semiconductor products that are compatible with the current RoHS requirements for all 6 substances, including the requirement that lead not exceed 0.1% by weight in homogeneous materials. Where designed to be soldered at high temperatures, TI Pb-Free products are suitable for use in specified lead-free processes.

Pb-Free (RoHS Exempt): This component has a RoHS exemption for either 1) lead-based flip-chip solder bumps used between the die and package, or 2) lead-based die adhesive used between the die and leadframe. The component is otherwise considered Pb-Free (RoHS compatible) as defined above.

Green (RoHS & no Sb/Br): TI defines "Green" to mean Pb-Free (RoHS compatible), and free of Bromine (Br) and Antimony (Sb) based flame retardants (Br or Sb do not exceed 0.1% by weight in homogeneous material)

⁽³⁾ MSL, Peak Temp. -- The Moisture Sensitivity Level rating according to the JEDEC industry standard classifications, and peak solder temperature.

Important Information and Disclaimer: The information provided on this page represents TI's knowledge and belief as of the date that it is provided. TI bases its knowledge and belief on information provided by third parties, and makes no representation or warranty as to the accuracy of such information. Efforts are underway to better integrate information from third parties. TI has taken and continues to take reasonable steps to provide representative and accurate information but may not have conducted destructive testing or chemical analysis on incoming materials and chemicals. TI and TI suppliers consider certain information to be proprietary, and thus CAS numbers and other limited information may not be available for release.

In no event shall TI's liability arising out of such information exceed the total purchase price of the TI part(s) at issue in this document sold by TI to Customer on an annual basis.

TAPE AND REEL INFORMATION
REEL DIMENSIONS

TAPE DIMENSIONS

A0	Dimension designed to accommodate the component width
B0	Dimension designed to accommodate the component length
K0	Dimension designed to accommodate the component thickness
W	Overall width of the carrier tape
P1	Pitch between successive cavity centers

TAPE AND REEL INFORMATION

*All dimensions are nominal

Device	Package Type	Package Drawing	Pins	SPQ	Reel Diameter (mm)	Reel Width W1 (mm)	A0 (mm)	B0 (mm)	K0 (mm)	P1 (mm)	W (mm)	Pin1 Quadrant
ISO7230ADWR	SOIC	DW	16	2000	330.0	16.4	10.75	10.7	2.7	12.0	16.0	Q1
ISO7231ADWR	SOIC	DW	16	2000	330.0	16.4	10.75	10.7	2.7	12.0	16.0	Q1

TAPE AND REEL BOX DIMENSIONS



*All dimensions are nominal

Device	Package Type	Package Drawing	Pins	SPQ	Length (mm)	Width (mm)	Height (mm)
ISO7230ADWR	SOIC	DW	16	2000	346.0	346.0	33.0
ISO7231ADWR	SOIC	DW	16	2000	346.0	346.0	33.0

DW (R-PDSO-G16)

PLASTIC SMALL OUTLINE

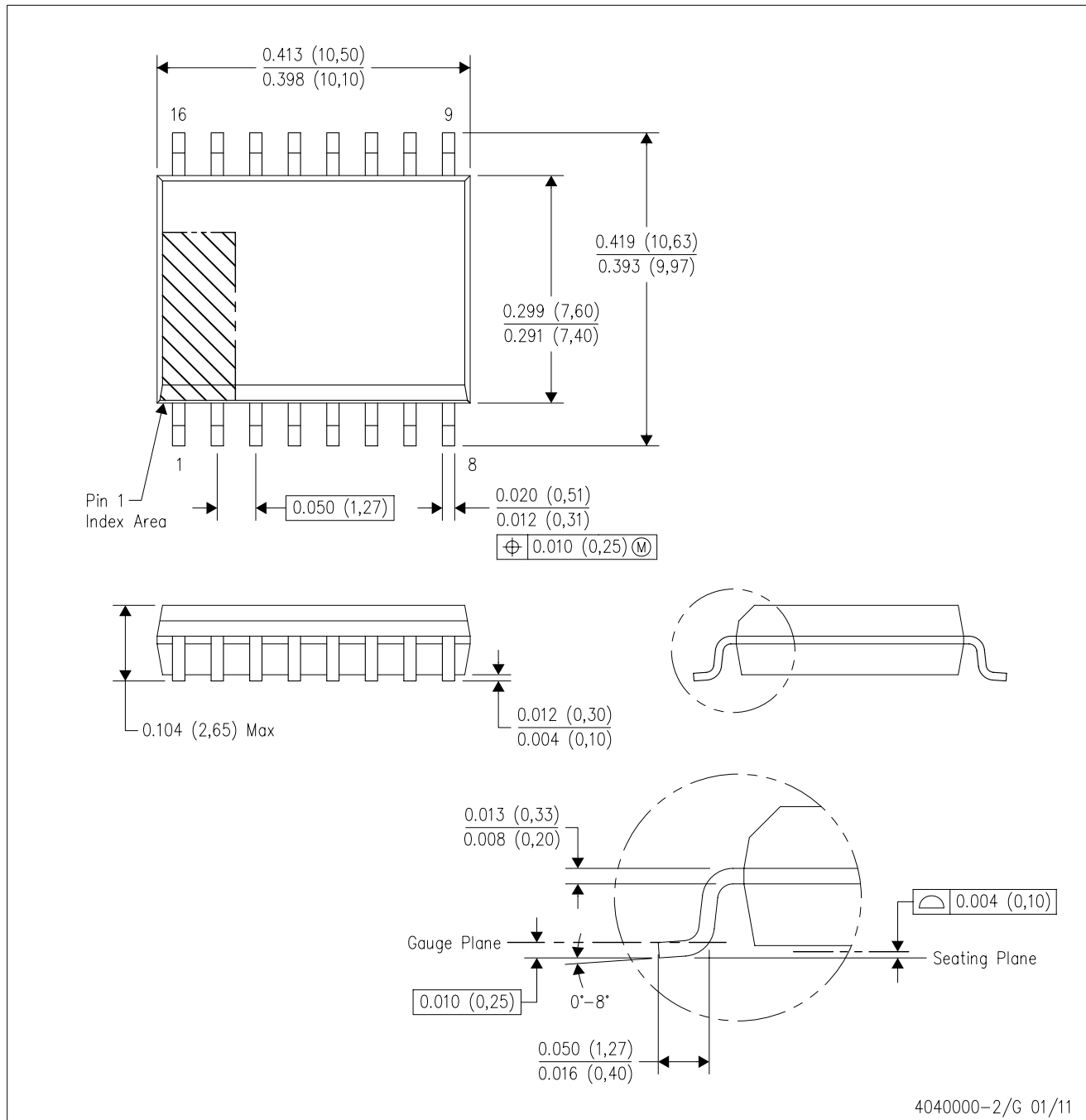

- NOTES:
- All linear dimensions are in inches (millimeters). Dimensioning and tolerancing per ASME Y14.5M-1994.
 - This drawing is subject to change without notice.
 - Body dimensions do not include mold flash or protrusion not to exceed 0.006 (0,15).
 - Falls within JEDEC MS-013 variation AA.

DW (R-PDSO-G16)

PLASTIC SMALL OUTLINE

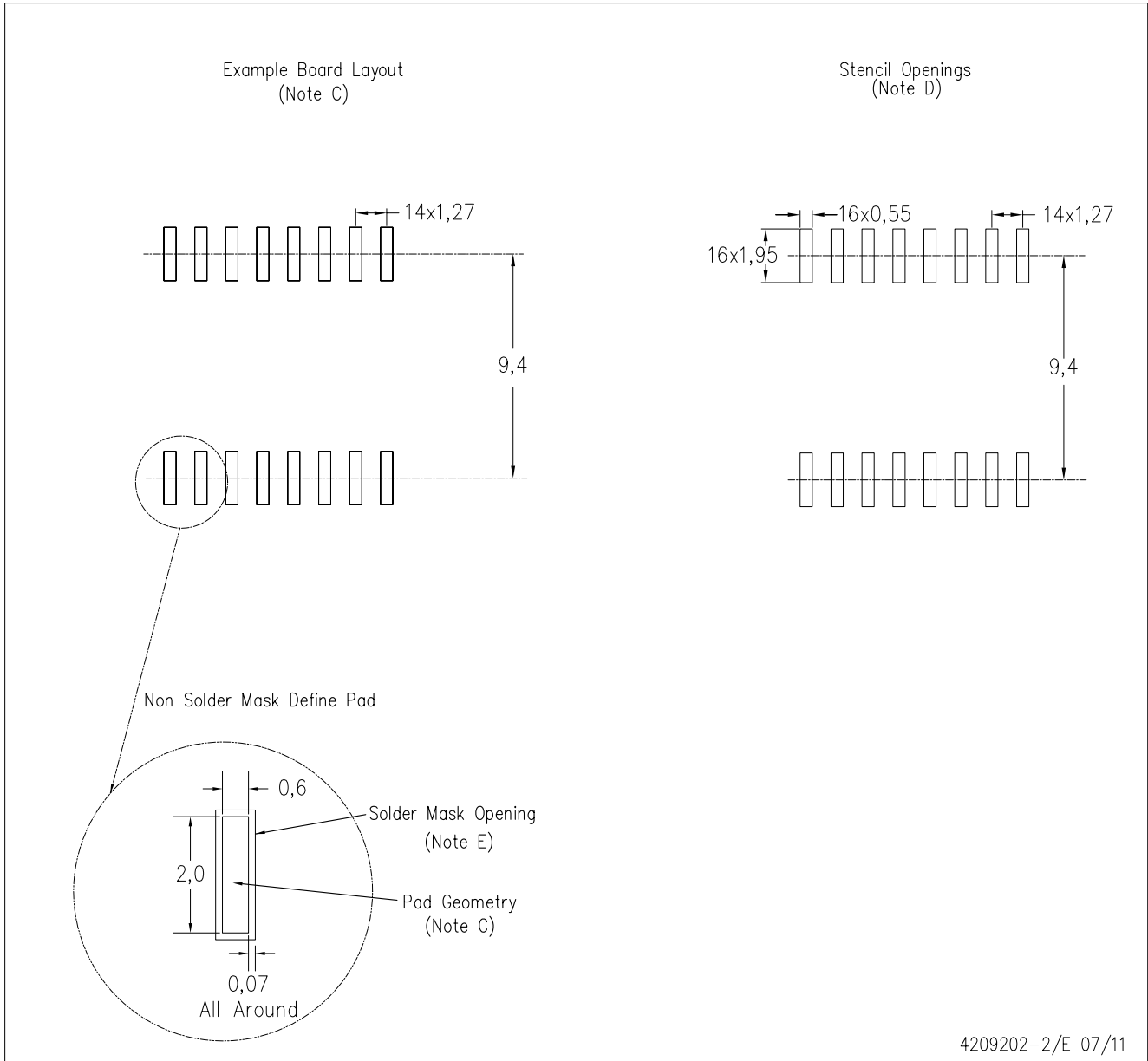

4209202-2/E 07/11

- NOTES:
- A. All linear dimensions are in millimeters.
 - B. This drawing is subject to change without notice.
 - C. Refer to IPC7351 for alternate board design.
 - D. Laser cutting apertures with trapezoidal walls and also rounding corners will offer better paste release. Customers should contact their board assembly site for stencil design recommendations. Refer to IPC-7525
 - E. Customers should contact their board fabrication site for solder mask tolerances between and around signal pads.

IMPORTANT NOTICE

Texas Instruments Incorporated and its subsidiaries (TI) reserve the right to make corrections, modifications, enhancements, improvements, and other changes to its products and services at any time and to discontinue any product or service without notice. Customers should obtain the latest relevant information before placing orders and should verify that such information is current and complete. All products are sold subject to TI's terms and conditions of sale supplied at the time of order acknowledgment.

TI warrants performance of its hardware products to the specifications applicable at the time of sale in accordance with TI's standard warranty. Testing and other quality control techniques are used to the extent TI deems necessary to support this warranty. Except where mandated by government requirements, testing of all parameters of each product is not necessarily performed.

TI assumes no liability for applications assistance or customer product design. Customers are responsible for their products and applications using TI components. To minimize the risks associated with customer products and applications, customers should provide adequate design and operating safeguards.

TI does not warrant or represent that any license, either express or implied, is granted under any TI patent right, copyright, mask work right, or other TI intellectual property right relating to any combination, machine, or process in which TI products or services are used. Information published by TI regarding third-party products or services does not constitute a license from TI to use such products or services or a warranty or endorsement thereof. Use of such information may require a license from a third party under the patents or other intellectual property of the third party, or a license from TI under the patents or other intellectual property of TI.

Reproduction of TI information in TI data books or data sheets is permissible only if reproduction is without alteration and is accompanied by all associated warranties, conditions, limitations, and notices. Reproduction of this information with alteration is an unfair and deceptive business practice. TI is not responsible or liable for such altered documentation. Information of third parties may be subject to additional restrictions.

Resale of TI products or services with statements different from or beyond the parameters stated by TI for that product or service voids all express and any implied warranties for the associated TI product or service and is an unfair and deceptive business practice. TI is not responsible or liable for any such statements.

TI products are not authorized for use in safety-critical applications (such as life support) where a failure of the TI product would reasonably be expected to cause severe personal injury or death, unless officers of the parties have executed an agreement specifically governing such use. Buyers represent that they have all necessary expertise in the safety and regulatory ramifications of their applications, and acknowledge and agree that they are solely responsible for all legal, regulatory and safety-related requirements concerning their products and any use of TI products in such safety-critical applications, notwithstanding any applications-related information or support that may be provided by TI. Further, Buyers must fully indemnify TI and its representatives against any damages arising out of the use of TI products in such safety-critical applications.

TI products are neither designed nor intended for use in military/aerospace applications or environments unless the TI products are specifically designated by TI as military-grade or "enhanced plastic." Only products designated by TI as military-grade meet military specifications. Buyers acknowledge and agree that any such use of TI products which TI has not designated as military-grade is solely at the Buyer's risk, and that they are solely responsible for compliance with all legal and regulatory requirements in connection with such use.

TI products are neither designed nor intended for use in automotive applications or environments unless the specific TI products are designated by TI as compliant with ISO/TS 16949 requirements. Buyers acknowledge and agree that, if they use any non-designated products in automotive applications, TI will not be responsible for any failure to meet such requirements.

Following are URLs where you can obtain information on other Texas Instruments products and application solutions:

Products

Audio	www.ti.com/audio
Amplifiers	amplifier.ti.com
Data Converters	dataconverter.ti.com
DLP® Products	www.dlp.com
DSP	dsp.ti.com
Clocks and Timers	www.ti.com/clocks
Interface	interface.ti.com
Logic	logic.ti.com
Power Mgmt	power.ti.com
Microcontrollers	microcontroller.ti.com
RFID	www.ti-rfid.com
OMAP Mobile Processors	www.ti.com/omap
Wireless Connectivity	www.ti.com/wirelessconnectivity

Applications

Automotive and Transportation	www.ti.com/automotive
Communications and Telecom	www.ti.com/communications
Computers and Peripherals	www.ti.com/computers
Consumer Electronics	www.ti.com/consumer-apps
Energy and Lighting	www.ti.com/energy
Industrial	www.ti.com/industrial
Medical	www.ti.com/medical
Security	www.ti.com/security
Space, Avionics and Defense	www.ti.com/space-avionics-defense
Video and Imaging	www.ti.com/video

TI E2E Community Home Page

e2e.ti.com

Mailing Address: Texas Instruments, Post Office Box 655303, Dallas, Texas 75265
Copyright © 2012, Texas Instruments Incorporated