



Low-Power, Single-Supply, CMOS INSTRUMENTATION AMPLIFIERS

FEATURES

- DESIGNED FOR LOW COST
- HIGH GAIN ACCURACY: $G = 5, 0.02\%, 2\text{ppm}/^\circ\text{C}$
- GAIN SET WITH EXT. RESISTORS FOR $> 5\text{V}$
- LOW OFFSET VOLTAGE: $\pm 250\mu\text{V}$
- HIGH CMRR: 94dB DC, 50dB at 45kHz
- LOW BIAS CURRENT: 0.5pA
- BANDWIDTH, SLEW RATE: 2.0MHz, 5V/ μs
- RAIL-TO-RAIL OUTPUT SWING: $(V_+) - 0.02\text{V}$
- WIDE TEMPERATURE RANGE: -55°C to $+125^\circ\text{C}$
- LOW QUIESCENT CURRENT: 490 μA max/chan
- SHUT DOWN: 0.01 μA
- MSOP-8 SINGLE AND TSSOP-14 DUAL PACKAGES

APPLICATIONS

- INDUSTRIAL SENSOR AMPLIFIERS:
Bridge, RTD, Thermocouple, Position
- PHYSIOLOGICAL AMPLIFIERS:
ECG, EEG, EMG
- A/D CONVERTER SIGNAL CONDITIONING
- DIFFERENTIAL LINE RECEIVERS WITH GAIN
- FIELD UTILITY METERS
- PCMCIA CARDS
- AUDIO AMPLIFIERS
- COMMUNICATION SYSTEMS
- TEST EQUIPMENT
- AUTOMOTIVE INSTRUMENTATION

DESCRIPTION

The INA331 and INA2331 are rail-to-rail output, low-power CMOS instrumentation amplifiers that offer wide range, single-supply operation as well as bipolar-supply operation. The INA331 family provides low-cost, low-noise amplification of differential signals with a low quiescent current of 415 μA (dropping to 0.01 μA when shutdown). Returning to normal operation within microseconds, this INA can be used for battery or multi-channel applications.

Configured internally in a gain of 5V/V, the INA331 offers flexibility in higher gains by choosing external resistors.

The INA331 rejects line noise and its harmonics, because common-mode error remains low even at higher frequencies.

High bandwidth and slew rate makes the INA331 ideal for directly driving sampling Analog-to-Digital (A/D) converters as well as general-purpose applications.

With high precision, low cost, and small packages, the INA331 outperforms discrete designs. They are specified for a wide temperature range of -55°C to $+125^\circ\text{C}$.

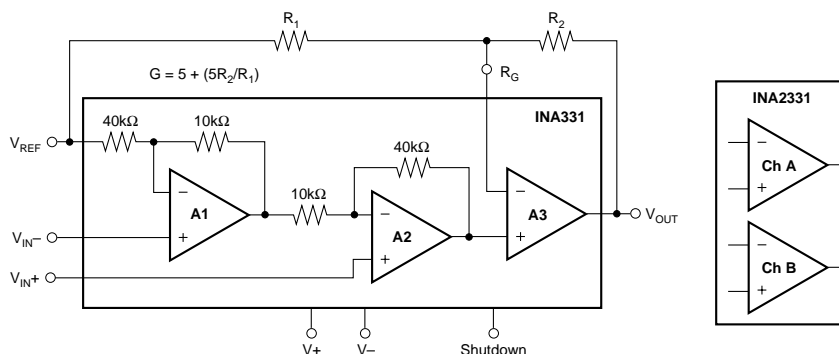

Please be aware that an important notice concerning availability, standard warranty, and use in critical applications of Texas Instruments semiconductor products and disclaimers thereto appears at the end of this data sheet.

All trademarks are the property of their respective owners.

PRODUCTION DATA information is current as of publication date. Products conform to specifications per the terms of Texas Instruments standard warranty. Production processing does not necessarily include testing of all parameters.

ABSOLUTE MAXIMUM RATINGS⁽¹⁾

Supply Voltage, V+ to V-	7.5V
Signal Input Terminals, Voltage ⁽²⁾	(V-) - 0.5V to (V+) + 0.5V
Current ⁽²⁾	10mA
Output Short-Circuit ⁽³⁾	Continuous
Operating Temperature	-55°C to +125°C
Storage Temperature	-65°C to +150°C
Junction Temperature	150°C
Lead Temperature (soldering, 10s)	300°C

NOTES: (1) Stresses above these ratings may cause permanent damage. Exposure to absolute maximum conditions for extended periods may degrade device reliability. (2) Input terminals are diode-clamped to the power-supply rails. Input signals that can swing more than 0.5V beyond the supply rails should be current limited to 10mA or less. (3) Short-circuit to ground, one amplifier per package.



ELECTROSTATIC DISCHARGE SENSITIVITY

This integrated circuit can be damaged by ESD. Texas Instruments recommends that all integrated circuits be handled with appropriate precautions. Failure to observe proper handling and installation procedures can cause damage.

ESD damage can range from subtle performance degradation to complete device failure. Precision integrated circuits may be more susceptible to damage because very small parametric changes could cause the device not to meet its published specifications.

PACKAGE/ORDERING INFORMATION⁽¹⁾

PRODUCT	PACKAGE-LEAD	PACKAGE DESIGNATOR	PACKAGE MARKING
Single INA331IDGK INA331AIDGK	MSOP-8 MSOP-8	DGK DGK	C31 C31
Dual INA2331AIPW	TSSOP-14	PW	2331A

NOTES: (1) For the most current package and ordering information, see the Package Option Addendum at the end of this document, or see the TI website at www.ti.com.

PIN CONFIGURATION

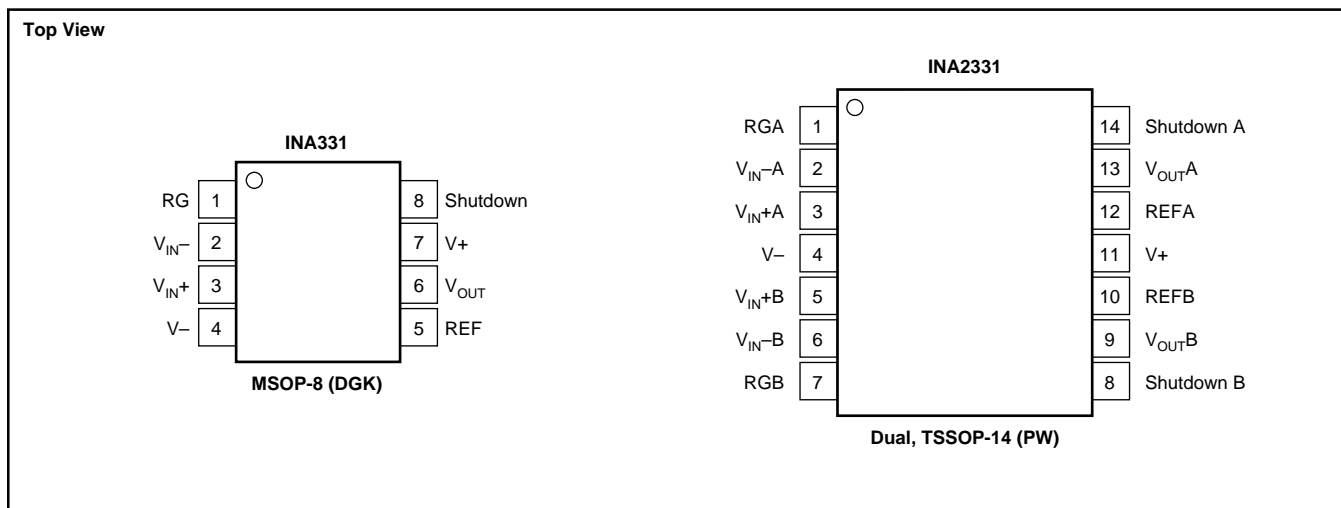

ELECTRICAL CHARACTERISTICS: $V_S = +2.7V$ to $+5.5V$

Boldface limits apply over the specified temperature range, $T_A = -55^\circ\text{C}$ to 125°C .

At $T_A = +25^\circ\text{C}$, $R_L = 10\text{k}\Omega$, $G = 25$, and $V_{\text{REF}} = V_S/2$, unless otherwise noted.

PARAMETER	CONDITION	INA331IDGK			INA331AIDGK INA2331AIPW			UNITS
		MIN	TYP	MAX	MIN	TYP	MAX	
INPUT								
Input Offset Voltage, RTI Over Temperature	$V_S = +5V$		± 250	± 500 ± 1.7		*	± 1000 ± 2.1	μV mV
Temperature Coefficient vs Power Supply vs Temperature	$V_S = +2.7V$ to $+5.5V$		± 5 ± 50	± 200 ± 220		*	*	$\mu\text{V}/^\circ\text{C}$ $\mu\text{V}/\text{V}$ $\mu\text{V}/\text{V}$
Long-Term Stability			± 0.4 $10^{13} \parallel 3$			*		$\mu\text{V}/\text{month}$
Input Impedance						*		$\Omega \parallel \text{pF}$
Input Common-Mode Range	$V_S = 2.7V$ $V_S = 5V$	0.35 0.55		1.5 3.8	*		*	V
Common-Mode Rejection -40°C to +85°C Over Temperature	$V_S = 5V$, $V_{\text{CM}} = 0.55V$ to $3.8V$ $V_S = 5V$, $V_{\text{CM}} = 0.55V$ to $3.8V$ $V_S = 5V$, $V_{\text{CM}} = 0.55V$ to $3.8V$ $V_S = 2.7V$, $V_{\text{CM}} = 0.35V$ to $1.5V$	90 77 72	94		80 75 70	*		dB dB dB
Crosstalk, Dual						114		dB
INPUT BIAS CURRENT								
Bias Current	$V_{\text{CM}} = V_S/2$		± 0.5	± 10		*	*	pA
Offset Current			± 0.5	± 10		*	*	pA
NOISE, RTI								
Voltage Noise: $f = 10\text{Hz}$	$R_S = 0\Omega$		280			*		$\text{nV}/\sqrt{\text{Hz}}$
$f = 100\text{Hz}$			96			*		$\text{nV}/\sqrt{\text{Hz}}$
$f = 1\text{kHz}$			46			*		$\text{nV}/\sqrt{\text{Hz}}$
$f = 0.1\text{Hz}$ to 10Hz			7			*		μV_{PP}
Current Noise: $f = 1\text{kHz}$			0.5			*		$\text{fA}/\sqrt{\text{Hz}}$
GAIN⁽¹⁾								
Gain Equation, Externally Set	$G > 5$		$G = 5 + (5R_2/R_1)$			*	*	V/V
Range of Gain		5		1000		*	*	%
Gain Error	$G = 5$		± 0.02	± 0.1		*	*	%
vs Temperature	$G = 5$		± 2	± 10		*	*	ppm/°C
Nonlinearity	$G = 25^{(2)}$, $V_S = 5V$, $V_O = 0.05$ to 4.95		± 0.001	± 0.010		*	*	% of FS
Over Temperature			± 0.002	± 0.015		*	*	% of FS
OUTPUT								
Output Voltage Swing from Rail ⁽³⁾	$R_L = 10\text{k}\Omega$		50	25		*	*	mV
Over Temperature	$G > 10$		50			*	*	mV
Capacitance Load Drive			See Typical Characteristics			*	*	pF
Short-Circuit Current			+48/-32			*	*	mA
FREQUENCY RESPONSE								
Bandwidth, -3dB	BW	$G = 25$		2.0		*		MHz
Slew Rate	SR	$V_S = 5V$, $G = 25$		5		*		V/ μs
Settling Time, 0.1%	t_s	$G = 25$, $C_L = 100\text{pF}$, $V_O = 2V$ step		1.7		*		μs
0.01%				2.5		*		μs
Overload Recovery		50% Input Overload $G = 25$		2		*		μs
POWER SUPPLY								
Specified Voltage Range			+2.7		+5.5	*	*	V
Operating Voltage Range			+2.5 to +5.5			*	*	V
Quiescent Current per Channel	I_Q	$V_{\text{SD}} > 2.5^{(3)}$		415	490	*	*	μA
Over Temperature					600	*	*	μA
Shutdown Quiescent Current/Chan	I_{SD}	$V_{\text{SD}} < 0.8^{(3)}$		0.01	1	*	*	μA
TEMPERATURE RANGE								
Specified/Operating Range			-55		+125	*	*	°C
Storage Range			-65		+150	*	*	°C
Thermal Resistance	θ_{JA}	MSOP-8, TSSOP-14 Surface Mount		150		*	*	°C/W

* Specifications same as INA331IDGK

NOTES: (1) Does not include errors from external gain setting resistors.

(2) Output voltage swings are measured between the output and power-supply rails. Output swings to rail only if $G \geq 10$. Output does not swing to positive rail if gain is less than 10.

(3) See typical characteristic *Percent Overshoot vs Load Capacitance*.

(4) See typical characteristic *Shutdown Voltage vs Supply Voltage*.

TYPICAL CHARACTERISTICS

At $T_A = +25^\circ\text{C}$, $V_S = 5\text{V}$, $V_{CM} = V_S/2$, $R_L = 10\text{k}\Omega$, and $C_L = 100\text{pF}$, unless otherwise noted.

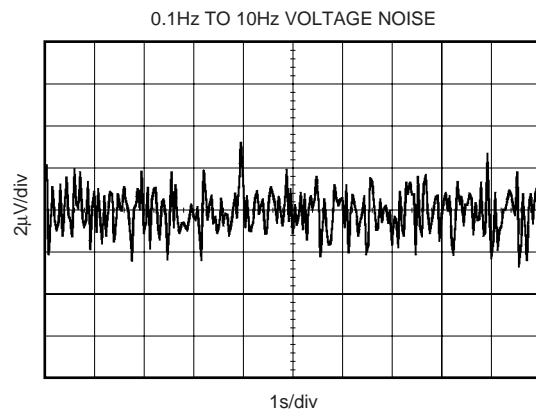
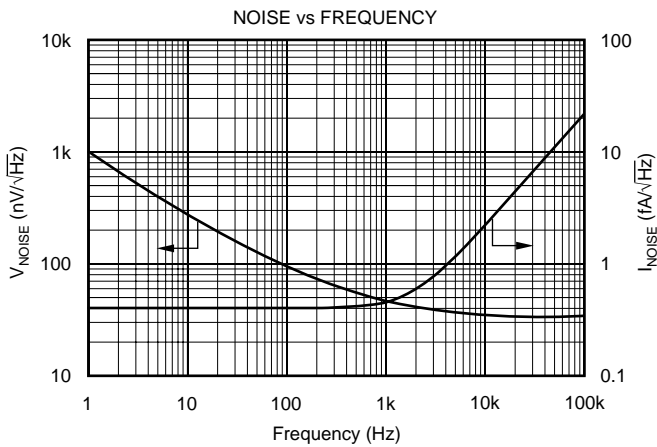
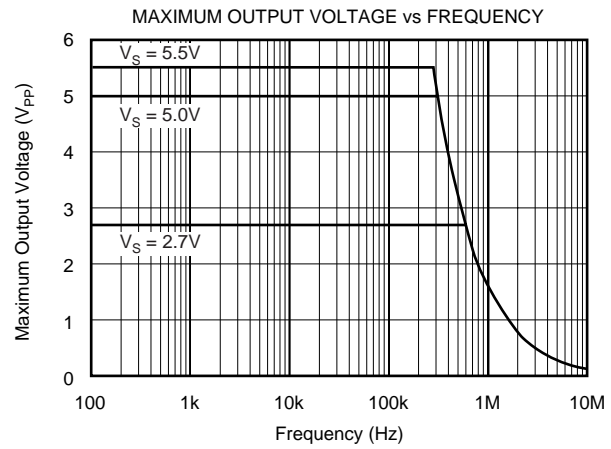
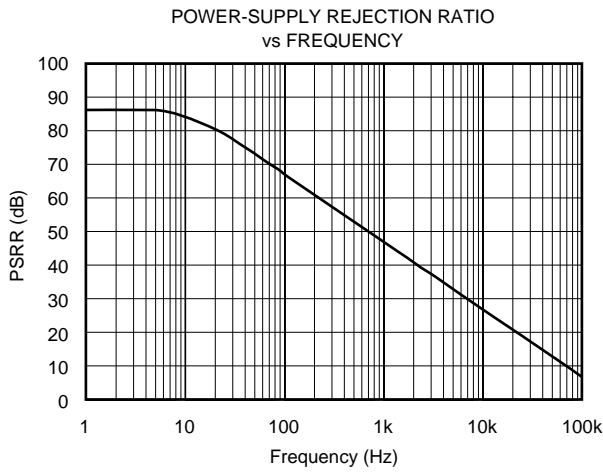
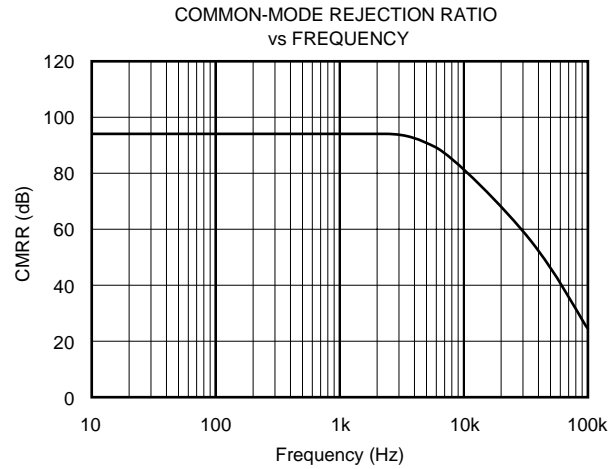
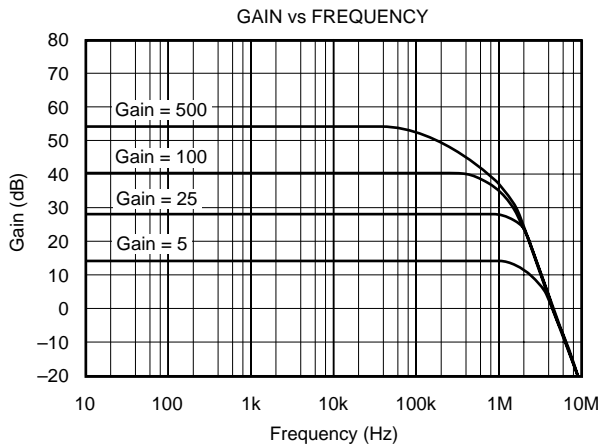

TYPICAL CHARACTERISTICS (Cont.)

At $T_A = +25^\circ\text{C}$, $V_S = 5\text{V}$, $V_{\text{CM}} = V_S/2$, $R_L = 10\text{k}\Omega$, and $C_L = 100\text{pF}$, unless otherwise noted.

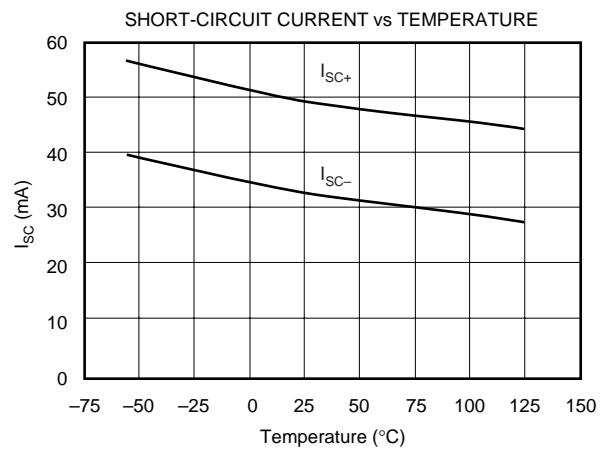
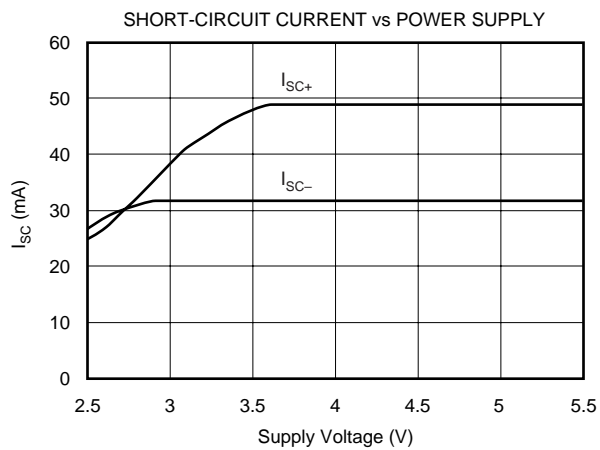
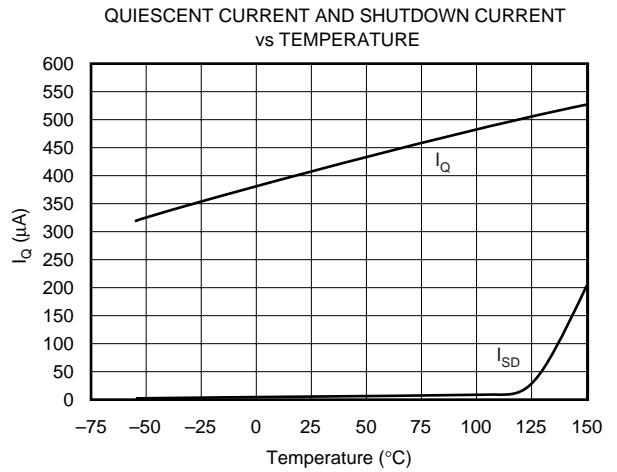
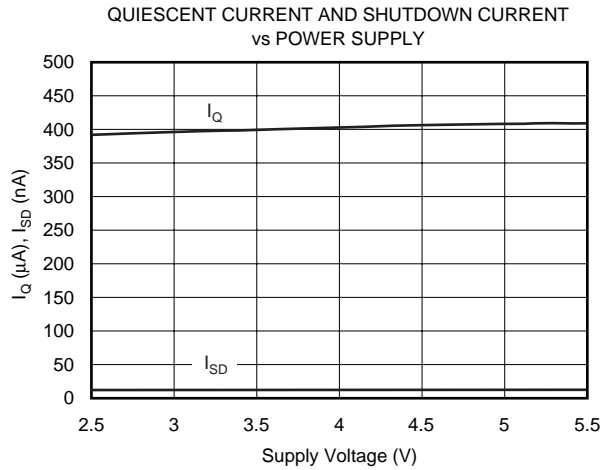
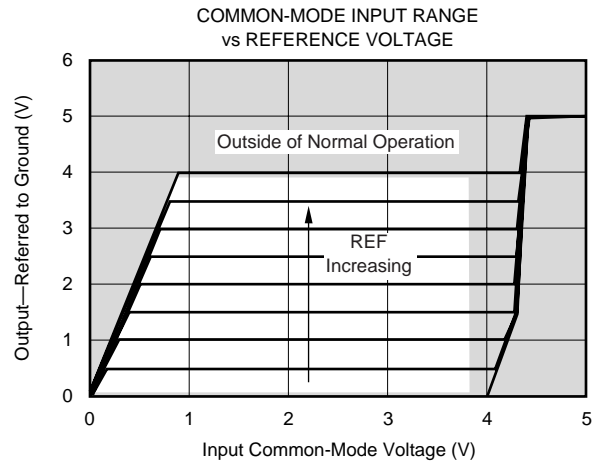
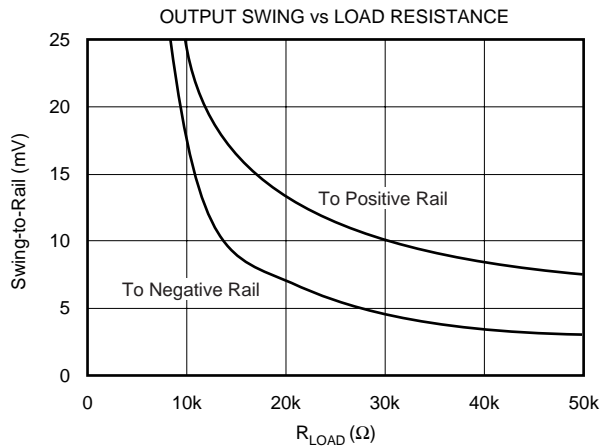

TYPICAL CHARACTERISTICS (Cont.)

At $T_A = +25^\circ\text{C}$, $V_S = 5\text{V}$, $V_{\text{CM}} = V_S/2$, $R_L = 10\text{k}\Omega$, and $C_L = 100\text{pF}$, unless otherwise noted.

SMALL-SIGNAL STEP RESPONSE ($G = 5$)

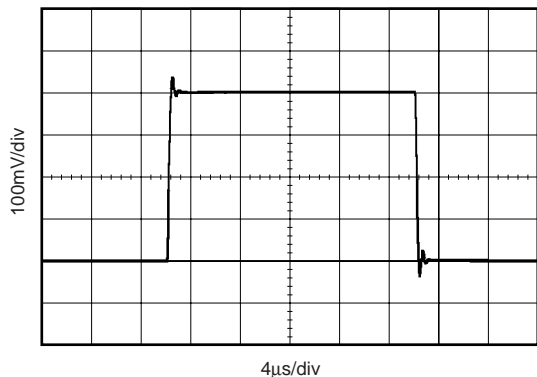

SMALL-SIGNAL STEP RESPONSE ($G = 100$)

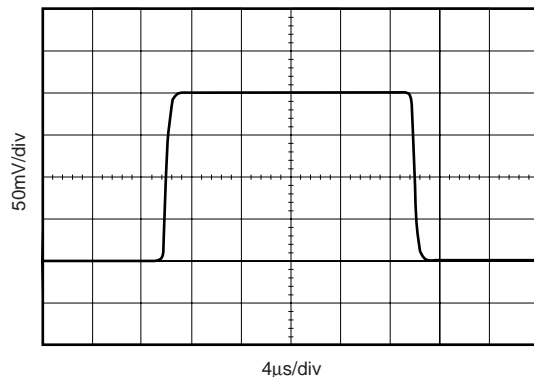

SMALL-SIGNAL STEP RESPONSE
($G = 5$, $C_L = 1000\text{pF}$)

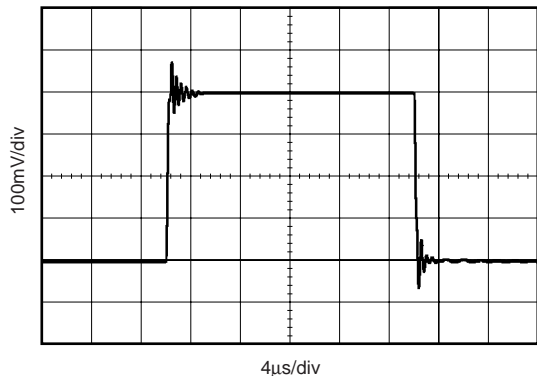

SMALL-SIGNAL STEP RESPONSE
($G = 100$, $C_L = 1000\text{pF}$)

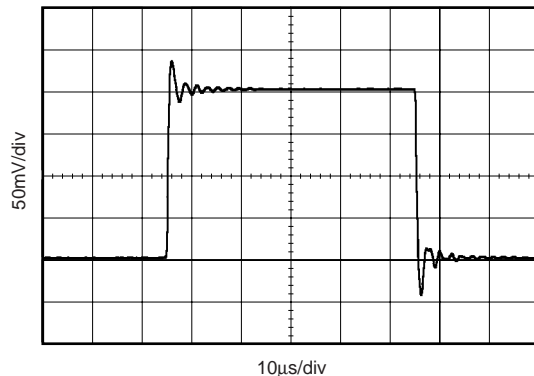

SMALL-SIGNAL STEP RESPONSE
($G = 100$, $C_L = 4700\text{pF}$)

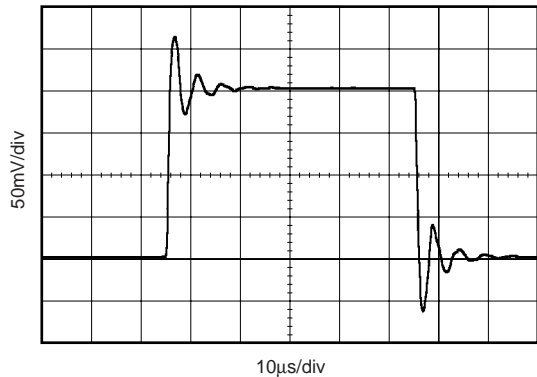

LARGE-SIGNAL STEP RESPONSE ($G = 25$)

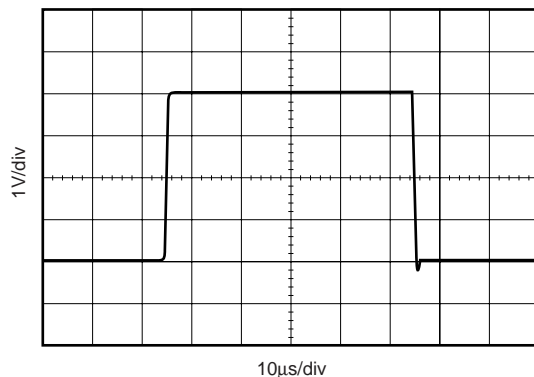

TYPICAL CHARACTERISTICS (Cont.)

At $T_A = +25^\circ\text{C}$, $V_S = 5\text{V}$, $V_{CM} = V_S/2$, $R_L = 10\text{k}\Omega$, and $C_L = 100\text{pF}$, unless otherwise noted.

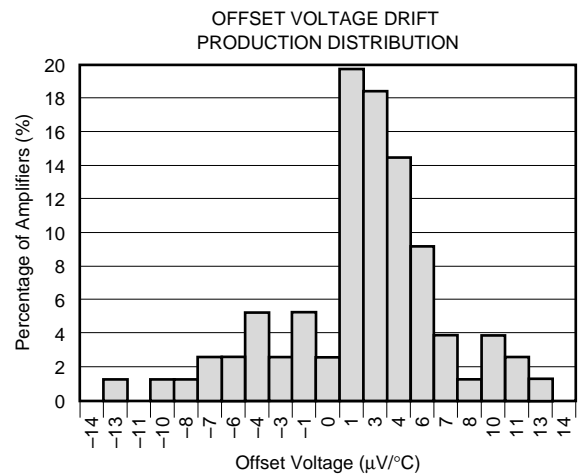
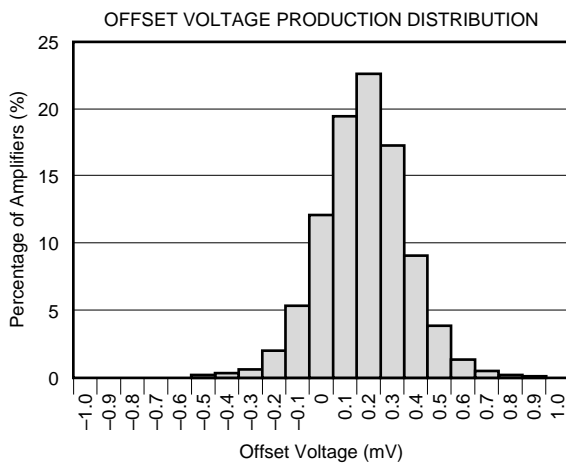
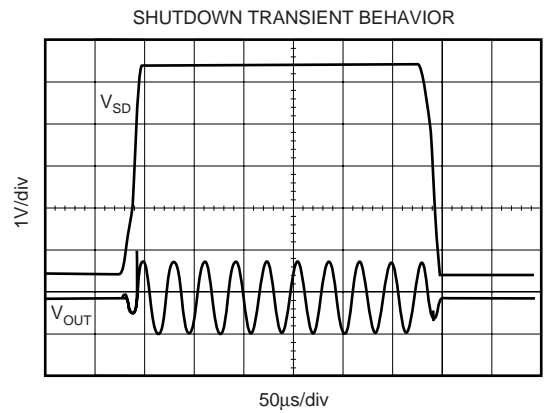
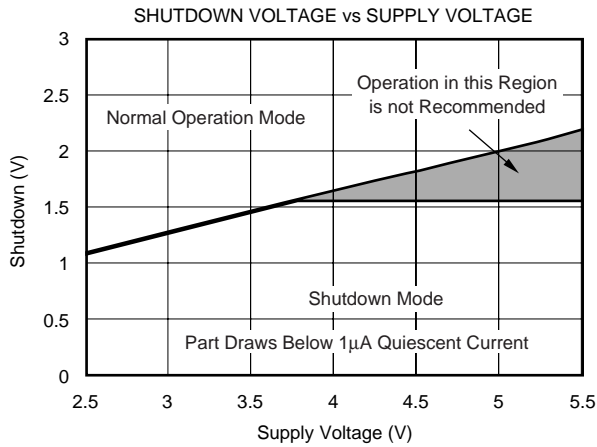
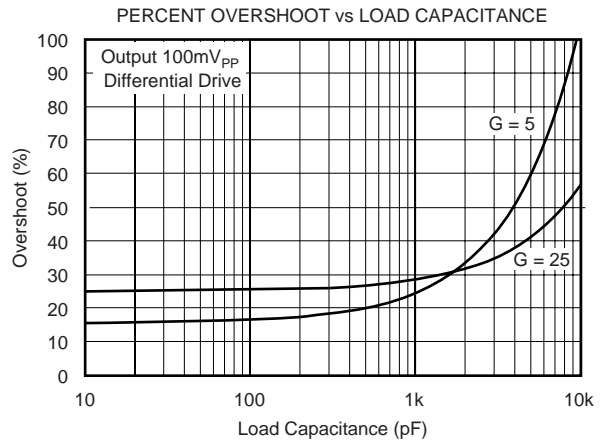
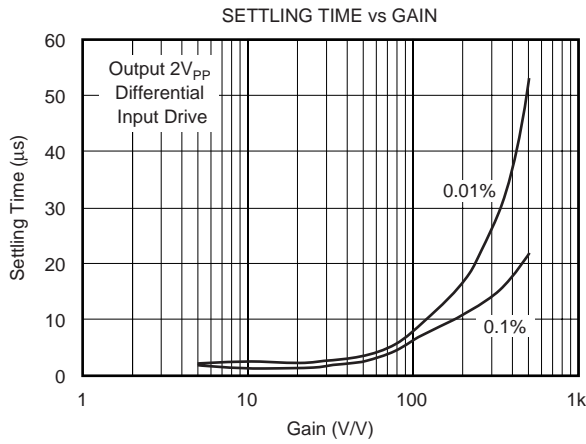

TYPICAL CHARACTERISTICS (Cont.)

At $T_A = +25^\circ\text{C}$, $V_S = 5\text{V}$, $V_{CM} = V_S/2$, $R_L = 10\text{k}\Omega$, and $C_L = 100\text{pF}$, unless otherwise noted.

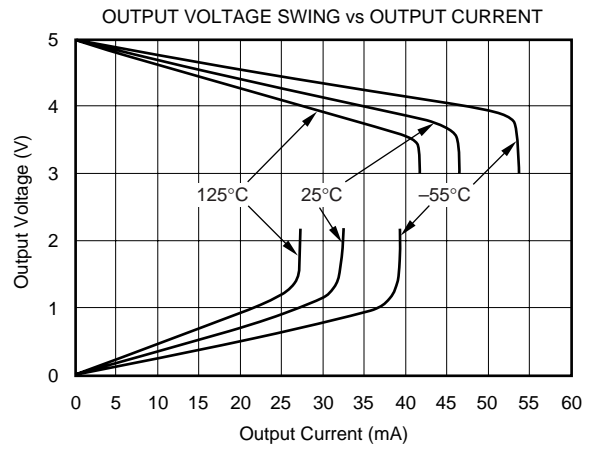
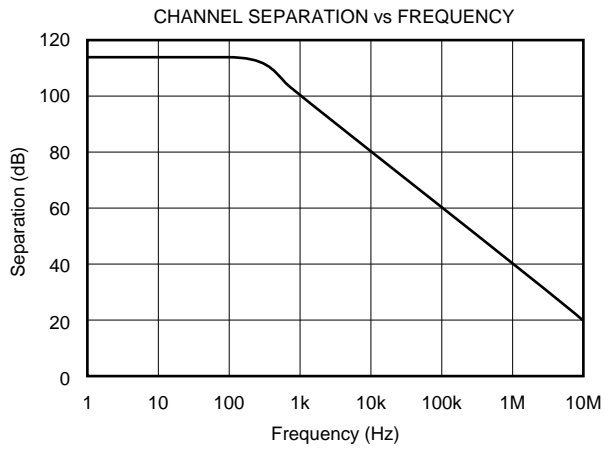
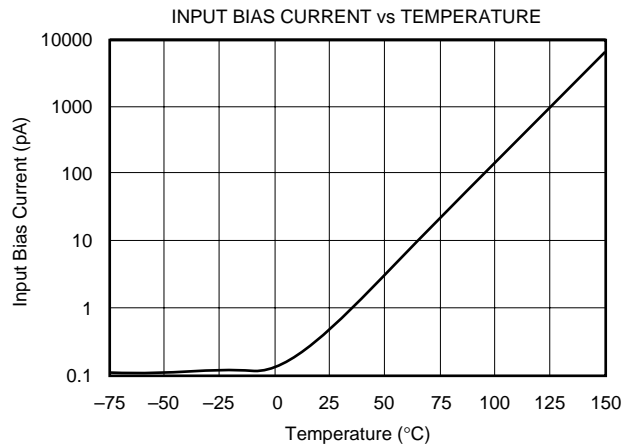
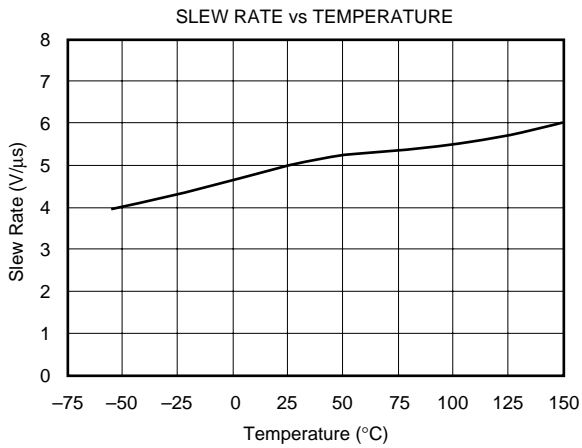

APPLICATIONS INFORMATION

The INA331 is a modified version of the classic “two op amp” instrumentation amplifier, with an additional gain amplifier.

Figure 1 shows the basic connections for the operation of the INA331 and INA2331. The power supply should be capacitively decoupled with 0.1µF capacitors as close to the INA331 as possible for noisy or high-impedance applications.

The output is referred to the reference terminal, which must be at least 1.2V below the positive supply rail.

OPERATING VOLTAGE

The INA331 family is fully specified over a supply range of +2.7V to +5.5V, with key parameters tested over the temperature range of -55°C to +125°C. Parameters that vary significantly with operating conditions, such as load conditions or temperature, are shown in the Typical Characteristics.

The INA331 may be operated on a single supply. Figure 2 shows a bridge amplifier circuit operated from a single +5V supply. The bridge provides a small differential voltage riding on an input common-mode voltage.

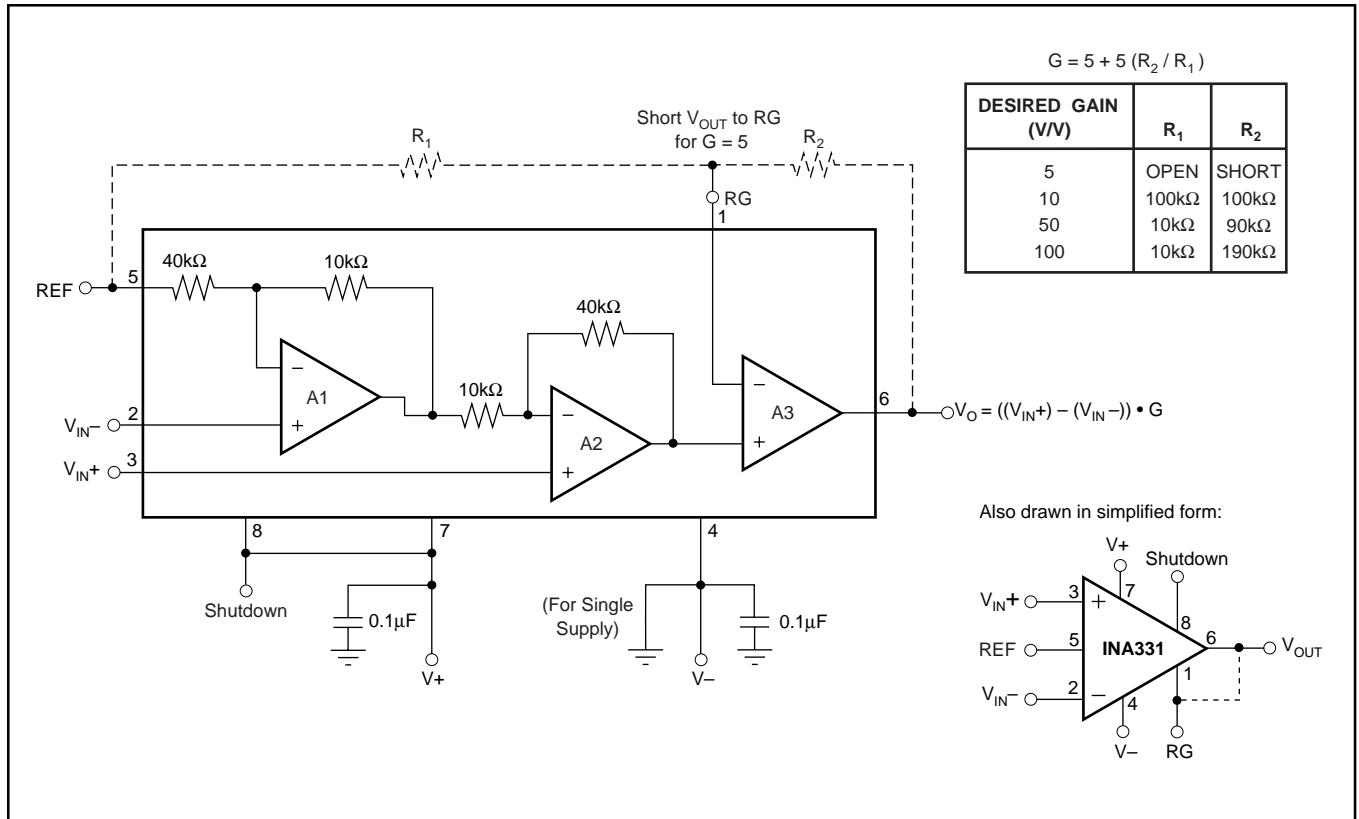

FIGURE 1. Basic Connections.

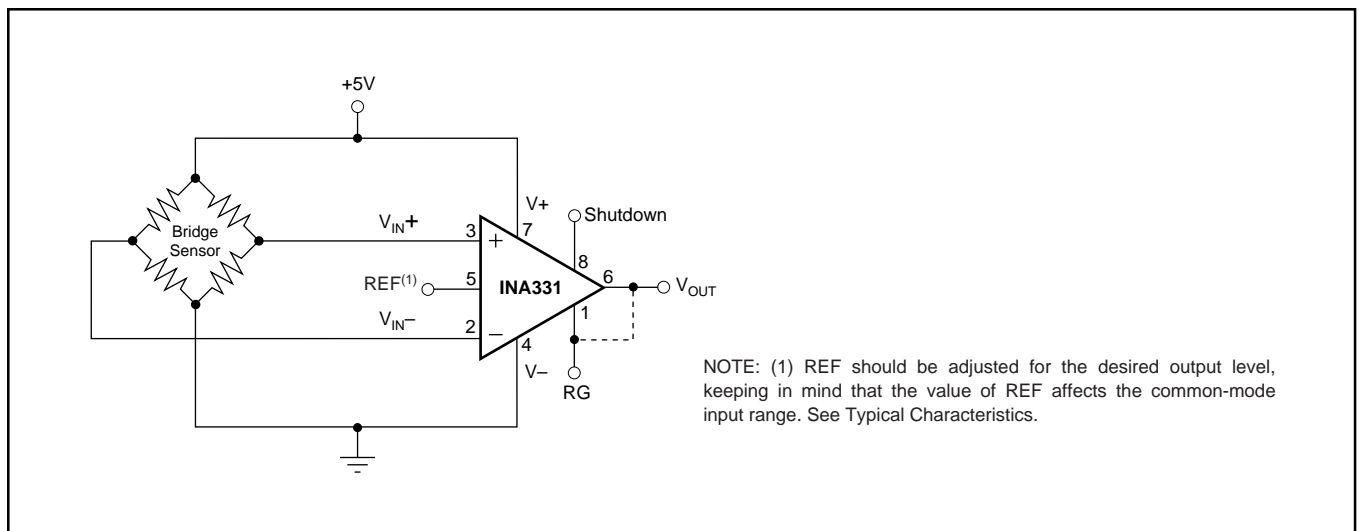

FIGURE 2. Single-Supply Bridge Amplifier.

SETTING THE GAIN

The ratio of R_2 to R_1 , or the impedance between pins 1, 5, and 6, determines the gain of the INA331. With an internally set gain of 5, the INA331 can be programmed for gains greater than 5 according to the following equation:

$$G = 5 + 5 (R_2/R_1)$$

The INA331 is designed to provide accurate gain, with gain error less than 0.1%. Setting gain with matching TC resistors will minimize gain drift. Errors from external resistors will add directly to the error, and may become dominant error sources.

COMMON-MODE INPUT RANGE

The upper limit of the common-mode input range is set by the common-mode input range of the second amplifier, A2, to 1.2V below positive supply. Under most conditions, the amplifier operates beyond this point with reduced performance. The lower limit of the input range is bounded by the output swing of amplifier A1, and is a function of the reference voltage according to the following equation:

$$V_{OA1} = 5/4 V_{CM} - 1/4 V_{REF}$$

(See typical characteristics *Common-Mode Input Range vs Reference Voltage*.)

REFERENCE

The reference terminal defines the zero output voltage level. In setting the reference voltage, the common-mode input of A3 should be considered according to the following equation:

$$V_{OA2} = V_{REF} + 5 (V_{IN+} - V_{IN-})$$

For ensured operation, V_{OA2} should be less than $V_{DD} - 1.2V$.

The reference pin requires a low-impedance connection. As little as 160Ω in series with the reference pin will degrade the CMRR to 80dB. The reference pin may be used to compensate for the offset voltage (see Offset Trimming section). The reference voltage level also influences the common-mode input range (see Common-Mode Input Range section).

INPUT BIAS CURRENT RETURN

With a high input impedance of $10^{13}\Omega$, the INA331 is ideal for use with high-impedance sources. The input bias current of less than 10pA makes the INA331 nearly independent of input impedance and ideal for low-power applications.

For proper operation, a path must be provided for input bias currents for both inputs. Without input bias current paths, the inputs will “float” to a potential that exceeds common-mode range and the input amplifier will saturate. Figure 3 shows

how the bias current path can be provided in the cases of microphone applications, thermistor applications, ground returns, and dc-coupled resistive bridge applications.

When differential source impedance is low, the bias current return path can be connected to one input. With higher source impedance, two equal resistors will provide a balanced input. The advantages are lower input offset voltage due to bias current flowing through the source impedance and better high-frequency gain.

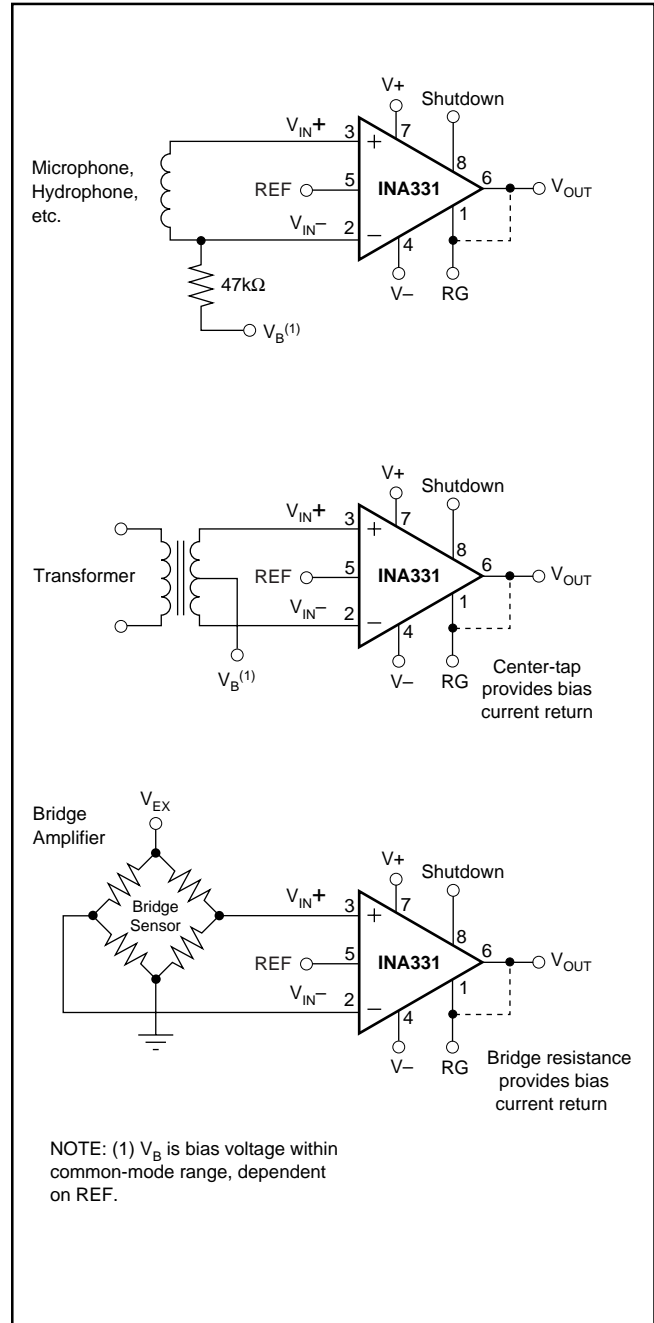

FIGURE 3. Providing an Input Common-Mode Path.

SHUTDOWN MODE

The shutdown pin of the INA331 is nominally connected to V+. When the pin is pulled below 0.8V on a 5V supply, the INA331 goes into sleep mode within nanoseconds. For actual shutdown threshold, see the typical characteristic *Shutdown Voltage vs Supply Voltage*. Drawing less than 2 μ A of current, and returning from sleep mode in microseconds, the shutdown feature is useful for portable applications. Once in 'sleep-mode' the amplifier has high output impedance, making the INA331 suitable for multiplexing.

RAIL-TO-RAIL OUTPUT

A class AB output stage with common-source transistors is used to achieve rail-to-rail output for gains of 10 or greater. For resistive loads greater than 10k Ω , the output voltage can swing to within 25mV of the supply rail while maintaining low gain error. For heavier loads and over temperature, see the typical characteristic *Output Voltage Swing vs Output Current*. The INA331's low output impedance at high frequencies makes it suitable for directly driving Capacitive-Input A/D converters, as shown in Figure 4.

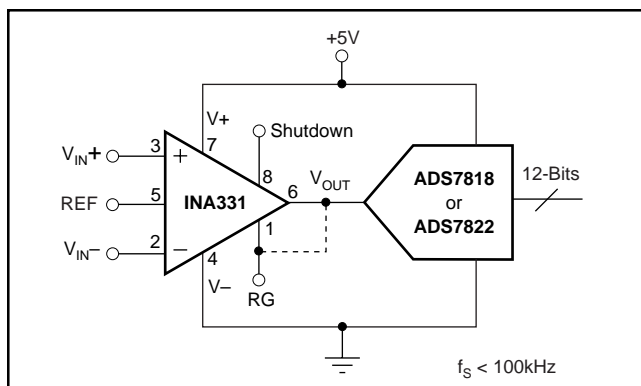

FIGURE 4. INA331 Directly Drives Capacitive-Input, High-Speed A/D Converter.

OUTPUT BUFFERING

The INA331 is optimized for a load impedance of 10k Ω or greater. For higher output current the INA331 can be buffered using the OPA340, as shown in Figure 5. The OPA340 can swing within 50mV of the supply rail, driving a 600 Ω load. The OPA340 is available in the tiny MSOP-8 package.

OFFSET TRIMMING

The INA331 is laser trimmed for low offset voltage. In the event that external offset adjustment is required, the offset can be adjusted by applying a correction voltage to the reference terminal. Figure 6 shows an optional circuit for trimming offset voltage. The voltage applied to the REF terminal is added to the output signal. The gain from REF to V_{OUT} is +1. An op amp buffer is used to provide low impedance at the REF terminal to preserve good common-mode rejection.

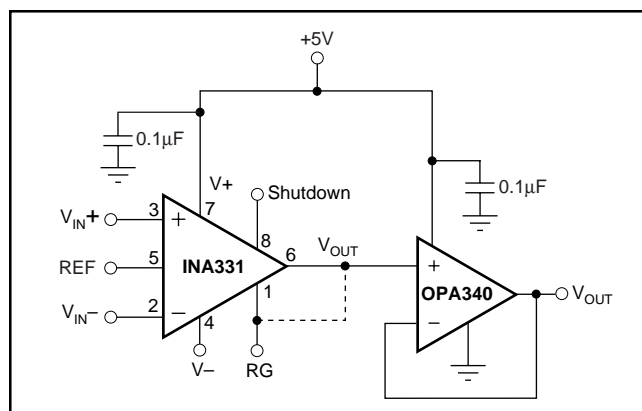

FIGURE 5. Output Buffering Circuit. Able to drive loads as low as 600 Ω .

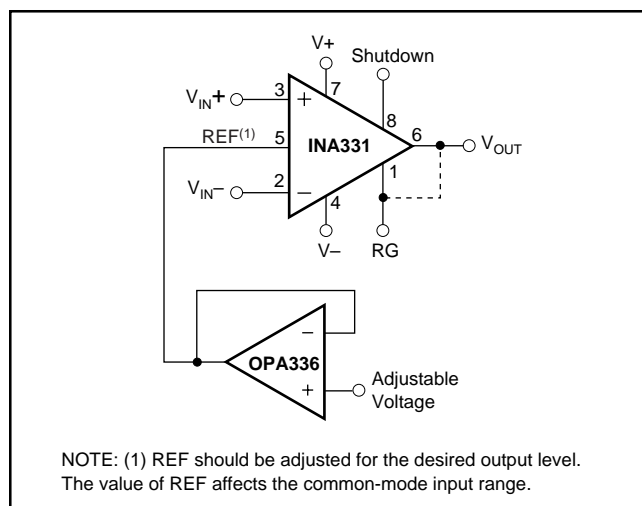

FIGURE 6. Optional Offset Trimming Voltage.

INPUT PROTECTION

Device inputs are protected by ESD diodes that will conduct if the input voltages exceed the power supplies by more than 500mV. Momentary voltages greater than 500mV beyond the power supply can be tolerated if the current through the input pins is limited to 10mA. This is easily accomplished with input resistor R_{LIM}, as shown in Figure 7. Many input signals are inherently current-limited to less than 10mA; therefore, a limiting resistor is not required.

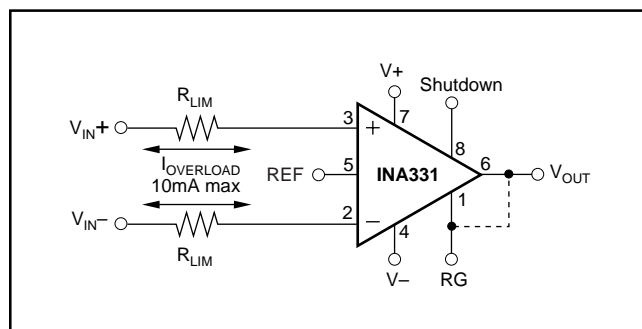

FIGURE 7. Sample Output Buffering Circuit.

OFFSET VOLTAGE ERROR CALCULATION

The offset voltage (V_{OS}) of the INA331IDGK is specified at a maximum of $500\mu\text{V}$ with a $+5\text{V}$ power supply and the common-mode voltage at $V_S/2$. Additional specifications for power-supply rejection and common-mode rejection are provided to allow the user to easily calculate worst-case expected offset under the conditions of a given application.

Power-Supply Rejection Ratio (PSRR) is specified in $\mu\text{V}/\text{V}$. For the INA331, worst case PSRR is $200\mu\text{V}/\text{V}$, which means for each volt of change in power supply, the offset may shift up to $200\mu\text{V}$. Common-Mode Rejection Ratio (CMRR) is specified in dB, which can be converted to $\mu\text{V}/\text{V}$ using the following equation:

$$\text{CMRR (in } \mu\text{V}/\text{V)} = 10^{[(\text{CMRR in dB})/-20]} \cdot 10^6$$

For the INA331, the worst case CMRR over the specified common-mode range is 90dB (at $G = 25$) or about $30\mu\text{V}/\text{V}$. This means that for every volt of change in common-mode, the offset will shift less than $30\mu\text{V}$.

These numbers can be used to calculate excursions from the specified offset voltage under different application conditions. For example, an application might configure the amplifier with a 3.3V supply with 1V common-mode. This configuration varies from the specified configuration, representing a 1.7V variation in power supply (5V in the offset specification versus 3.3V in the application) and a 0.65V variation in common-mode voltage from the specified $V_S/2$.

Calculation of the worst-case expected offset would be as follows:

$$\begin{aligned} \text{Adjusted } V_{OS} &= \text{Maximum specified } V_{OS} + \\ &\quad (\text{power-supply variation}) \cdot \text{PSRR} + \\ &\quad (\text{common-mode variation}) \cdot \text{CMRR} \end{aligned}$$

$$\begin{aligned} V_{OS} &= 0.5\text{mV} + (1.7\text{V} \cdot 200\mu\text{V}) + (0.65\text{V} \cdot 30\mu\text{V}) \\ &= \pm 0.860\text{mV} \end{aligned}$$

However, the typical value will be smaller, as seen in the Typical Characteristics.

FEEDBACK CAPACITOR IMPROVES RESPONSE

For optimum settling time and stability with high-impedance feedback networks, it may be necessary to add a feedback capacitor across the feedback resistor, R_F , as shown in Figure 8. This capacitor compensates for the zero created by the feedback network impedance and the INA331's RG-pin input capacitance (and any parasitic layout capacitance). The effect becomes more significant with higher impedance networks. Also, R_X and C_L can be added to reduce high-frequency noise.

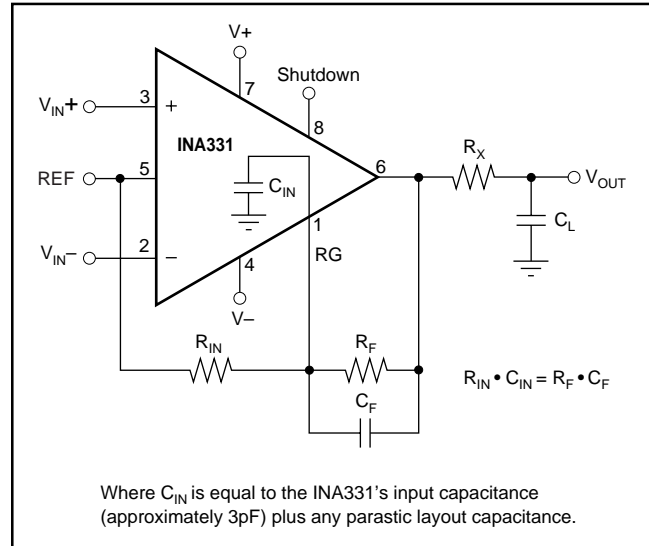

FIGURE 8. Feedback Capacitor Improves Dynamic Performance.

It is suggested that a variable capacitor be used for the feedback capacitor since input capacitance may vary between instrumentation amplifiers, and layout capacitance is difficult to determine. For the circuit shown in Figure 8, the value of the variable feedback capacitor should be chosen by the following equation:

$$R_{IN} \cdot C_{IN} = R_F \cdot C_F$$

Where C_{IN} is equal to the INA331's RG-pin input capacitance (typically 3pF) plus the layout capacitance. The capacitor can be varied until optimum performance is obtained.

PACKAGING INFORMATION

Orderable Device	Status ⁽¹⁾	Package Type	Package Drawing	Pins	Package Qty	Eco Plan ⁽²⁾	Lead/Ball Finish	MSL Peak Temp ⁽³⁾
INA2331AIPWR	ACTIVE	TSSOP	PW	14	2500	Green (RoHS & no Sb/Br)	CU NIPDAU	Level-2-260C-1 YEAR
INA2331AIPWRG4	ACTIVE	TSSOP	PW	14	2500	Green (RoHS & no Sb/Br)	CU NIPDAU	Level-2-260C-1 YEAR
INA2331AIPWT	ACTIVE	TSSOP	PW	14	250	Green (RoHS & no Sb/Br)	CU NIPDAU	Level-2-260C-1 YEAR
INA331AIDGKR	ACTIVE	MSOP	DGK	8	2500	TBD	CU NIPDAU	Level-1-220C-UNLIM
INA331AIDGKT	ACTIVE	MSOP	DGK	8	250	TBD	CU NIPDAU	Level-1-220C-UNLIM
INA331IDGKR	ACTIVE	MSOP	DGK	8	2500	TBD	CU NIPDAU	Level-1-220C-UNLIM
INA331IDGKT	ACTIVE	MSOP	DGK	8	250	TBD	CU NIPDAU	Level-1-220C-UNLIM

⁽¹⁾ The marketing status values are defined as follows:

ACTIVE: Product device recommended for new designs.

LIFEBUY: TI has announced that the device will be discontinued, and a lifetime-buy period is in effect.

NRND: Not recommended for new designs. Device is in production to support existing customers, but TI does not recommend using this part in a new design.

PREVIEW: Device has been announced but is not in production. Samples may or may not be available.

OBSOLETE: TI has discontinued the production of the device.

⁽²⁾ Eco Plan - The planned eco-friendly classification: Pb-Free (RoHS) or Green (RoHS & no Sb/Br) - please check <http://www.ti.com/productcontent> for the latest availability information and additional product content details.

TBD: The Pb-Free/Green conversion plan has not been defined.

Pb-Free (RoHS): TI's terms "Lead-Free" or "Pb-Free" mean semiconductor products that are compatible with the current RoHS requirements for all 6 substances, including the requirement that lead not exceed 0.1% by weight in homogeneous materials. Where designed to be soldered at high temperatures, TI Pb-Free products are suitable for use in specified lead-free processes.

Green (RoHS & no Sb/Br): TI defines "Green" to mean Pb-Free (RoHS compatible), and free of Bromine (Br) and Antimony (Sb) based flame retardants (Br or Sb do not exceed 0.1% by weight in homogeneous material)

⁽³⁾ MSL, Peak Temp. -- The Moisture Sensitivity Level rating according to the JEDEC industry standard classifications, and peak solder temperature.

Important Information and Disclaimer:The information provided on this page represents TI's knowledge and belief as of the date that it is provided. TI bases its knowledge and belief on information provided by third parties, and makes no representation or warranty as to the accuracy of such information. Efforts are underway to better integrate information from third parties. TI has taken and continues to take reasonable steps to provide representative and accurate information but may not have conducted destructive testing or chemical analysis on incoming materials and chemicals. TI and TI suppliers consider certain information to be proprietary, and thus CAS numbers and other limited information may not be available for release.

In no event shall TI's liability arising out of such information exceed the total purchase price of the TI part(s) at issue in this document sold by TI to Customer on an annual basis.

PW (R-PDSO-G**)

PLASTIC SMALL-OUTLINE PACKAGE

14 PINS SHOWN



4040064/F 01/97

- NOTES: A. All linear dimensions are in millimeters.
 B. This drawing is subject to change without notice.
 C. Body dimensions do not include mold flash or protrusion not to exceed 0,15.
 D. Falls within JEDEC MO-153

IMPORTANT NOTICE

Texas Instruments Incorporated and its subsidiaries (TI) reserve the right to make corrections, modifications, enhancements, improvements, and other changes to its products and services at any time and to discontinue any product or service without notice. Customers should obtain the latest relevant information before placing orders and should verify that such information is current and complete. All products are sold subject to TI's terms and conditions of sale supplied at the time of order acknowledgment.

TI warrants performance of its hardware products to the specifications applicable at the time of sale in accordance with TI's standard warranty. Testing and other quality control techniques are used to the extent TI deems necessary to support this warranty. Except where mandated by government requirements, testing of all parameters of each product is not necessarily performed.

TI assumes no liability for applications assistance or customer product design. Customers are responsible for their products and applications using TI components. To minimize the risks associated with customer products and applications, customers should provide adequate design and operating safeguards.

TI does not warrant or represent that any license, either express or implied, is granted under any TI patent right, copyright, mask work right, or other TI intellectual property right relating to any combination, machine, or process in which TI products or services are used. Information published by TI regarding third-party products or services does not constitute a license from TI to use such products or services or a warranty or endorsement thereof. Use of such information may require a license from a third party under the patents or other intellectual property of the third party, or a license from TI under the patents or other intellectual property of TI.

Reproduction of information in TI data books or data sheets is permissible only if reproduction is without alteration and is accompanied by all associated warranties, conditions, limitations, and notices. Reproduction of this information with alteration is an unfair and deceptive business practice. TI is not responsible or liable for such altered documentation.

Resale of TI products or services with statements different from or beyond the parameters stated by TI for that product or service voids all express and any implied warranties for the associated TI product or service and is an unfair and deceptive business practice. TI is not responsible or liable for any such statements.

Following are URLs where you can obtain information on other Texas Instruments products and application solutions:

Products		Applications	
Amplifiers	amplifier.ti.com	Audio	www.ti.com/audio
Data Converters	dataconverter.ti.com	Automotive	www.ti.com/automotive
DSP	dsp.ti.com	Broadband	www.ti.com/broadband
Interface	interface.ti.com	Digital Control	www.ti.com/digitalcontrol
Logic	logic.ti.com	Military	www.ti.com/military
Power Mgmt	power.ti.com	Optical Networking	www.ti.com/opticalnetwork
Microcontrollers	microcontroller.ti.com	Security	www.ti.com/security
		Telephony	www.ti.com/telephony
		Video & Imaging	www.ti.com/video
		Wireless	www.ti.com/wireless

Mailing Address: Texas Instruments
Post Office Box 655303 Dallas, Texas 75265