

CD54HCT373, CD74HCT373 OCTAL TRANSPARENT D-TYPE LATCHES WITH 3-STATE OUTPUTS

SCLS453 – FEBRUARY 2001

- 4.5-V to 5.5-V V_{CC} Operation Range
- Wide Operating Temperature Range of -55°C to 125°C
- Balanced Propagation Delays and Transition Times
- Standard Outputs Drive up to 10 LS-TTL Loads
- Significant Power Reduction Compared to LS-TTL Logic ICs
- Inputs Are TTL-Voltage Compatible

CD54HCT373 . . . F PACKAGE
CD74HCT373 . . . E OR M PACKAGE
(TOP VIEW)

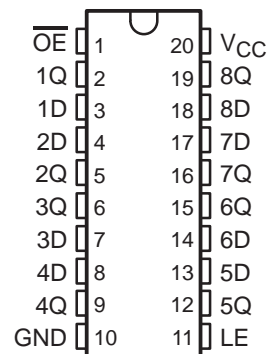

description

The 'HCT373 devices are octal transparent D-type latches. When the latch-enable (LE) input is high, the Q outputs follow the data (D) inputs. When LE is low, the Q outputs are latched at the logic levels of the D inputs.

A buffered output-enable ($\overline{\text{OE}}$) input can be used to place the eight outputs in either a normal logic state (high or low) or the high-impedance state. In the high-impedance state, the outputs neither load nor drive the bus lines significantly. The high-impedance state and increased drive provide the capability to drive bus lines without interface or pullup components.

$\overline{\text{OE}}$ does not affect the internal operations of the latches. Old data can be retained or new data can be entered while the outputs are in the high-impedance state.

To ensure the high-impedance state during power up or power down, $\overline{\text{OE}}$ should be tied to V_{CC} through a pullup resistor; the minimum value of the resistor is determined by the current-sinking capability of the driver.

ORDERING INFORMATION

T_A	PACKAGE†		ORDERABLE PART NUMBER	TOP-SIDE MARKING
-55°C to 125°C	PDIP – E	Tube	CD74HCT373E	CD74HCT373E
	SOIC – M	Tube	CD74HCT373M	HCT373M
		Tape and reel	CD74HCT373M96	
	CDIP – F	Tube	CD54HCT373F	CD54HCT373F
		Tube	CD54HCT373F3A	CD54HCT373F3A

† Package drawings, standard packing quantities, thermal data, symbolization, and PCB design guidelines are available at www.ti.com/sc/package.



Please be aware that an important notice concerning availability, standard warranty, and use in critical applications of Texas Instruments semiconductor products and disclaimers thereto appears at the end of this data sheet.

PRODUCTION DATA information is current as of publication date. Products conform to specifications per the terms of Texas Instruments standard warranty. Production processing does not necessarily include testing of all parameters.

 **TEXAS
INSTRUMENTS**

POST OFFICE BOX 655303 • DALLAS, TEXAS 75265

Copyright © 2001, Texas Instruments Incorporated
On products compliant to MIL-PRF-38535, all parameters are tested unless otherwise noted. On all other products, production processing does not necessarily include testing of all parameters.

CD54HCT373, CD74HCT373 OCTAL TRANSPARENT D-TYPE LATCHES WITH 3-STATE OUTPUTS

SCLS453 – FEBRUARY 2001

FUNCTION TABLE
(each latch)

INPUTS			OUTPUT
\overline{OE}	LE	D	Q
L	H	H	H
L	H	L	L
L	L	X	Q_0
H	X	X	Z

logic symbol†

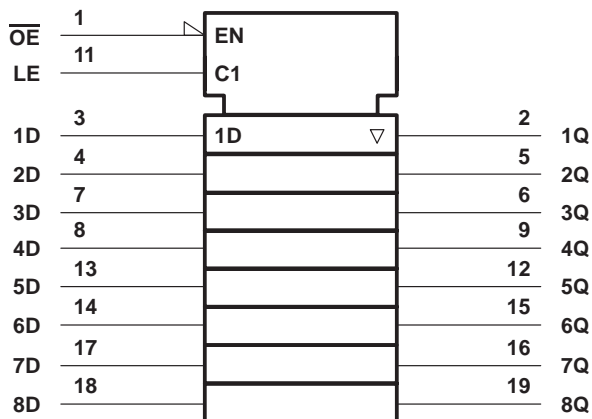

† This symbol is in accordance with ANSI/IEEE Std 91-1984 and IEC Publication 617-12.

logic diagram (positive logic)

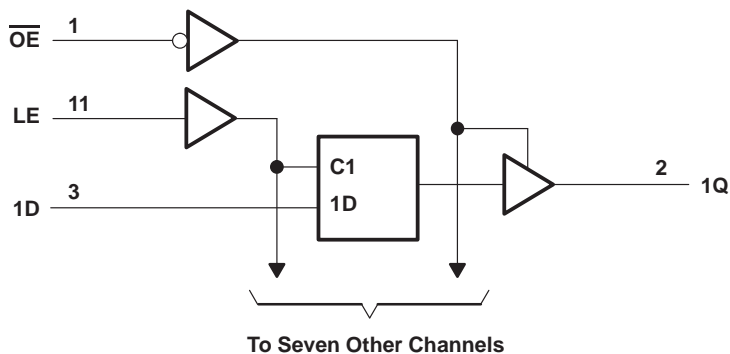

CD54HCT373, CD74HCT373
OCTAL TRANSPARENT D-TYPE LATCHES
WITH 3-STATE OUTPUTS

SCLS453 – FEBRUARY 2001

absolute maximum ratings over operating free-air temperature range (unless otherwise noted)†

Supply voltage range, V_{CC}	–0.5 V to 7 V
Input clamp current, I_{IK} ($V_I < 0$ or $V_I > V_{CC}$) (see Note 1)	±20 mA
Output clamp current, I_{OK} ($V_O < 0$ or $V_O > V_{CC}$) (see Note 1)	±20 mA
Continuous output drain current per output, I_O ($V_O = 0$ to V_{CC})	±35 mA
Continuous output source or sink current per output, I_O ($V_O = 0$ to V_{CC})	±25 mA
Continuous current through V_{CC} or GND	±50 mA
Package thermal impedance, θ_{JA} (see Note 2): E package	69°C/W
M package	58°C/W
Storage temperature range, T_{stg}	–65°C to 150°C

† Stresses beyond those listed under “absolute maximum ratings” may cause permanent damage to the device. These are stress ratings only, and functional operation of the device at these or any other conditions beyond those indicated under “recommended operating conditions” is not implied. Exposure to absolute-maximum-rated conditions for extended periods may affect device reliability.

- NOTES: 1. The input and output voltage ratings may be exceeded if the input and output current ratings are observed.
 2. The package thermal impedance is calculated in accordance with JESD 51-7.

recommended operating conditions (see Note 3)

		MIN	MAX	UNIT
V_{CC}	Supply voltage	4.5	5.5	V
V_{IH}	High-level input voltage	2		V
V_{IL}	Low-level input voltage		0.8	V
V_I	Input voltage		V_{CC}	V
V_O	Output voltage		V_{CC}	V
$\Delta t/\Delta v$	Input transition rise or fall rate		500	ns
T_A	Operating free-air temperature	–55	125	°C

NOTE 3: All unused inputs of the device must be held at V_{CC} or GND to ensure proper device operation. Refer to the TI application report, *Implications of Slow or Floating CMOS Inputs*, literature number SCBA004.

electrical characteristics over recommended operating free-air temperature range (unless otherwise noted)

PARAMETER	TEST CONDITIONS	V_{CC}	$T_A = 25^\circ\text{C}$		$T_A = -40^\circ\text{C}$ TO 85°C		$T_A = -55^\circ\text{C}$ TO 125°C		UNIT
			MIN	MAX	MIN	MAX	MIN	MAX	
V_{OH}	$V_I = V_{IH}$ or V_{IL}	4.5 V	$I_{OH} = -20 \mu\text{A}$		4.4		4.4		V
			$I_{OH} = -6 \text{ mA}$		3.98		3.7		
		6 V	$I_{OH} = -7.8 \text{ mA}$		5.48		5.34		
V_{OL}	$V_I = V_{IH}$ or V_{IL}	4.5 V	$I_{OL} = 20 \mu\text{A}$		0.1		0.1		V
			$I_{OL} = 6 \text{ mA}$		0.26		0.33		
		6 V	$I_{OL} = 7.8 \text{ mA}$		0.26		0.33		
I_I	$V_I = V_{CC}$ or 0	5.5 V	±0.1		±1		±1		μA
I_{OZ}	$V_O = V_{CC}$ or 0	6 V	±0.5		±5		±10		μA
I_{CC}	$V_I = V_{CC}$ or 0, $I_O = 0$	5.5 V	8		80		160		μA
ΔI_{CC}^\ddagger	One input at $V_{CC} - 2.1 \text{ V}$, Other inputs at 0 or V_{CC}	4.5 V to 5.5 V	360		450		490		μA
C_i			10		10		10		pF
C_o			10		10		10		pF

‡ For dual-supply systems, theoretical worst-case ($V_I = 2.4 \text{ V}$, $V_{CC} = 5.5 \text{ V}$) specification is 1.8 mA.



**CD54HCT373, CD74HCT373
OCTAL TRANSPARENT D-TYPE LATCHES
WITH 3-STATE OUTPUTS**

SCLS453 – FEBRUARY 2001

HCT INPUT LOADING TABLE

INPUT	UNIT LOAD
\overline{OE}	1.5
Any D	0.4
LE	1

Unit load is ΔI_{CC} limit specified in electrical characteristics table (e.g., 360 μ A max at 25°C).

timing requirements over recommended operating free-air temperature range, $V_{CC} = 4.5$ V (unless otherwise noted) (see Figure 1)

		$T_A = 25^\circ\text{C}$		$T_A = -40^\circ\text{C}$ TO 85°C		$T_A = -55^\circ\text{C}$ TO 125°C		UNIT
		MIN	MAX	MIN	MAX	MIN	MAX	
t_w	Pulse duration, LE high	16		20		24		ns
t_{su}	Setup time, data before LE \downarrow	13		16		20		ns
t_h	Hold time, data after LE \downarrow	10		13		15		ns

switching characteristics over recommended operating free-air temperature range, $V_{CC} = 4.5$ V (unless otherwise noted) (see Figure 1)

PARAMETER	FROM (INPUT)	TO (OUTPUT)	LOAD CAPACITANCE	$T_A = 25^\circ\text{C}$		$T_A = -40^\circ\text{C}$ TO 85°C		$T_A = -55^\circ\text{C}$ TO 125°C		UNIT
				MIN	MAX	MIN	MAX	MIN	MAX	
t_{pd}	D	Q	$C_L = 50$ pF	32		40		48		ns
	LE			35		44		53		
t_{en}	\overline{OE}	Q	$C_L = 50$ pF	35		44		53		ns
t_{dis}	\overline{OE}	Q	$C_L = 50$ pF	35		44		53		ns
t_t		Q	$C_L = 50$ pF	12		15		18		ns

operating characteristics, $V_{CC} = 5$ V, $T_A = 25^\circ\text{C}$

PARAMETER	TYP	UNIT
C_{pd} Power dissipation capacitance	53	pF



PARAMETER MEASUREMENT INFORMATION

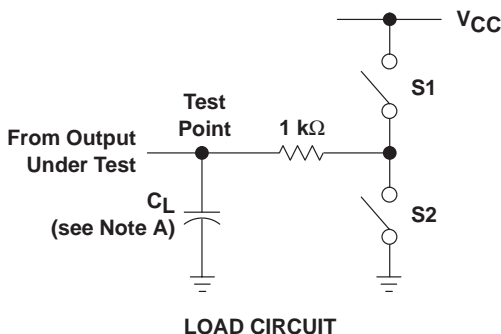

PARAMETER		S1	S2
t_{en}	t_{pZH}	Open	Closed
	t_{pZL}	Closed	Open
t_{dis}	t_{pHZ}	Open	Closed
	t_{pLZ}	Closed	Open
t_{pd} or t_t		Open	Open

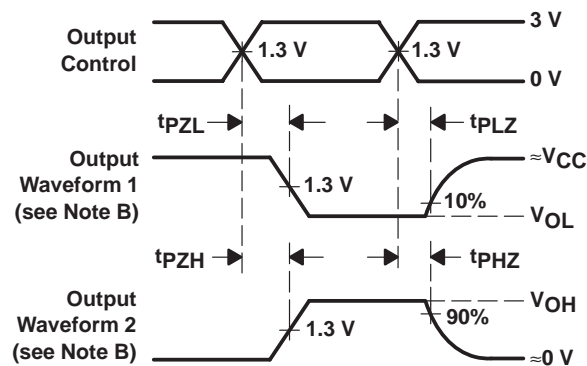
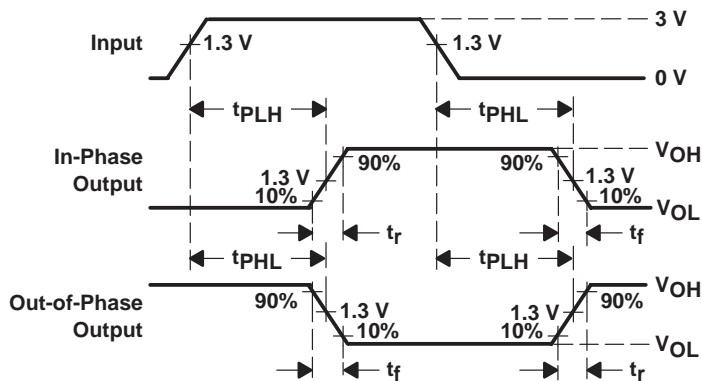
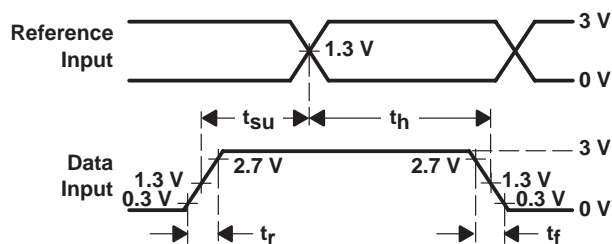
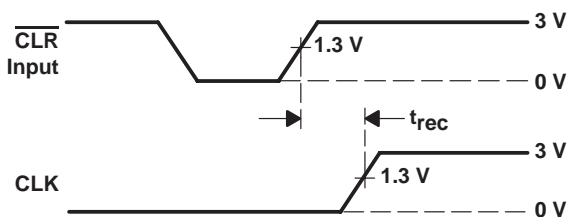
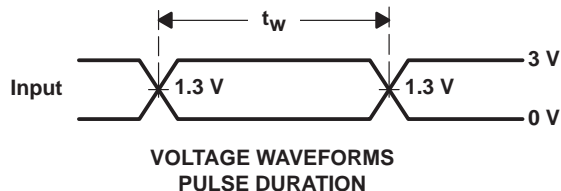

- NOTES:
- A. C_L includes probe and test-fixture capacitance.
 - B. Waveform 1 is for an output with internal conditions such that the output is low except when disabled by the output control. Waveform 2 is for an output with internal conditions such that the output is high except when disabled by the output control.
 - C. Phase relationships between waveforms were chosen arbitrarily. All input pulses are supplied by generators having the following characteristics: $PRR \leq 1$ MHz, $Z_O = 50 \Omega$, $t_r = 6$ ns, $t_f = 6$ ns.
 - D. For clock inputs, f_{max} is measured with the input duty cycle at 50%.
 - E. The outputs are measured one at a time with one input transition per measurement.
 - F. t_{pLZ} and t_{pHZ} are the same as t_{dis} .
 - G. t_{pZL} and t_{pZH} are the same as t_{en} .
 - H. t_{pLH} and t_{pHL} are the same as t_{pd} .

Figure 1. Load Circuit and Voltage Waveforms

IMPORTANT NOTICE

Texas Instruments and its subsidiaries (TI) reserve the right to make changes to their products or to discontinue any product or service without notice, and advise customers to obtain the latest version of relevant information to verify, before placing orders, that information being relied on is current and complete. All products are sold subject to the terms and conditions of sale supplied at the time of order acknowledgment, including those pertaining to warranty, patent infringement, and limitation of liability.

TI warrants performance of its products to the specifications applicable at the time of sale in accordance with TI's standard warranty. Testing and other quality control techniques are utilized to the extent TI deems necessary to support this warranty. Specific testing of all parameters of each device is not necessarily performed, except those mandated by government requirements.

Customers are responsible for their applications using TI components.

In order to minimize risks associated with the customer's applications, adequate design and operating safeguards must be provided by the customer to minimize inherent or procedural hazards.

TI assumes no liability for applications assistance or customer product design. TI does not warrant or represent that any license, either express or implied, is granted under any patent right, copyright, mask work right, or other intellectual property right of TI covering or relating to any combination, machine, or process in which such products or services might be or are used. TI's publication of information regarding any third party's products or services does not constitute TI's approval, license, warranty or endorsement thereof.

Reproduction of information in TI data books or data sheets is permissible only if reproduction is without alteration and is accompanied by all associated warranties, conditions, limitations and notices. Representation or reproduction of this information with alteration voids all warranties provided for an associated TI product or service, is an unfair and deceptive business practice, and TI is not responsible nor liable for any such use.

Resale of TI's products or services with statements different from or beyond the parameters stated by TI for that product or service voids all express and any implied warranties for the associated TI product or service, is an unfair and deceptive business practice, and TI is not responsible nor liable for any such use.

Also see: [Standard Terms and Conditions of Sale for Semiconductor Products](http://www.ti.com/sc/docs/stdterms.htm), www.ti.com/sc/docs/stdterms.htm

Mailing Address:

Texas Instruments
Post Office Box 655303
Dallas, Texas 75265