

**High-Speed CMOS Logic
4-Bit Bidirectional Universal Shift Register**

Features

- **Four Operating Modes**
 - Shift Right, Shift Left, Hold and Reset
- **Synchronous Parallel or Serial Operation**
- **Typical $f_{MAX} = 60\text{MHz}$ at $V_{CC} = 5\text{V}$, $C_L = 15\text{pF}$, $T_A = 25^\circ\text{C}$**
- **Asynchronous Master Reset**
- **Fanout (Over Temperature Range)**
 - Standard Outputs 10 LSTTL Loads
 - Bus Driver Outputs 15 LSTTL Loads
- **Wide Operating Temperature Range . . . -55°C to 125°C**
- **Balanced Propagation Delay and Transition Times**
- **Significant Power Reduction Compared to LSTTL Logic ICs**
- **HC Types**
 - 2V to 6V Operation
 - High Noise Immunity: $N_{IL} = 30\%$, $N_{IH} = 30\%$ of V_{CC} at $V_{CC} = 5\text{V}$
- **HCT Types**
 - 4.5V to 5.5V Operation
 - Direct LSTTL Input Logic Compatibility, $V_{IL} = 0.8\text{V}$ (Max), $V_{IH} = 2\text{V}$ (Min)
 - CMOS Input Compatibility, $I_I \leq 1\mu\text{A}$ at V_{OL} , V_{OH}

Description

The 'HC194 and CD74HCT194 are 4-bit shift registers with Asynchronous Master Reset (\overline{MR}). In the parallel mode (S_0 and S_1 are high), data is loaded into the associated flip-flop and appears at the output after the positive transition of the clock input (CP). During parallel loading serial data flow is inhibited. Shift left and shift right are accomplished synchronously on the positive clock edge with serial data entered at the shift left (DSL) serial input for the shift right mode, and at the shift right (DSR) serial input for the shift left mode. Clearing the register is accomplished by a Low applied to the Master Reset (\overline{MR}) pin.

Ordering Information

PART NUMBER	TEMP. RANGE (°C)	PACKAGE
CD54HC194F3A	-55 to 125	16 Ld Cerdip
CD74HC194E	-55 to 125	16 Ld PDIP
CD74HC194M	-55 to 125	16 Ld SOIC
CD74HC194M96	-55 to 125	16 Ld SOIC
CD74HC194NSR	-55 to 125	16 Ld SOP
CD74HC194PWR	-55 to 125	16 Ld TSSOP
CD74HCT194E	-55 to 125	16 Ld PDIP

NOTES:

1. When ordering, use the entire part number. Add the suffix 96 to obtain the variant in the tape and reel.
2. Die for this part number is available which meets all electrical specifications. Please contact your local TI sales office or customer service for ordering information.

Pinout

CD54HC194 (CERDIP)
CD74HC194 (PDIP, SOIC, SOP, TSSOP)
CD74HCT194 (PDIP, SOIC)
TOP VIEW

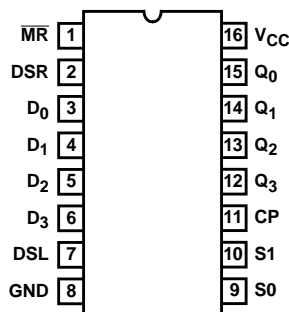

CD54/74HC194, CD74HCT194

Functional Diagram

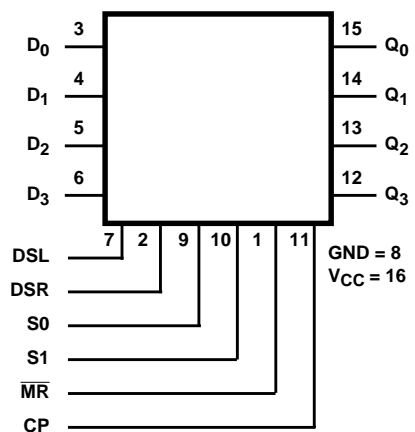

TRUTH TABLE

OPERATING MODE	INPUTS							OUTPUT			
	CP	$\overline{\text{MR}}$	S1	S0	DSR	DSL	D_n	Q_0	Q_1	Q_2	Q_3
Reset (Clear)	X	L	X	X	X	X	X	L	L	L	L
Hold (Do Nothing)	X	H	l (Note 2)	l (Note 2)	X	X	X	q_0	q_1	q_2	q_3
Shift Left	\uparrow	H	h	l (Note 2)	X	l	X	q_1	q_2	q_3	L
	\uparrow	H	h	l (Note 2)	X	h	X	q_1	q_2	q_3	H
Shift Right	\uparrow	H	l (Note 2)	h	l	X	X	L	q_0	q_1	q_2
	\uparrow	H	l (Note 2)	h	h	X	X	H	q_0	q_1	q_2
Parallel Load	\uparrow	H	h	h	X	X	d_n	d_0	d_1	q_2	d_3

NOTES:

1. H = High Voltage Level,
 h = High Voltage Level One Set-up Time Prior To The Low to High Clock Transition,
 L = Low Voltage Level,
 l = Low Voltage Level One Set-up Time Prior to the Low to High Clock Transition,
 d_n (q_n) = Lower Case Letters Indicate the State of the Referenced Input (or output) One Set-up Time Prior to the Low To High Clock Transition,
 X = Don't Care,
 \uparrow = Transition from Low to High Level
2. The High to Low transition of the S0 and S1 Inputs on the 'HC194, CD74HCT194 should only take place while CP is High for Conventional Operation.

CD54/74HC194, CD74HCT194

Absolute Maximum Ratings

DC Supply Voltage, V_{CC}	-0.5V to 7V
DC Input Diode Current, I_{IK}	
For $V_I < -0.5V$ or $V_I > V_{CC} + 0.5V$	$\pm 20mA$
DC Output Diode Current, I_{OK}	
For $V_O < -0.5V$ or $V_O > V_{CC} + 0.5V$	$\pm 20mA$
DC Output Source or Sink Current per Output Pin, I_O	
For $V_O > -0.5V$ or $V_O < V_{CC} + 0.5V$	$\pm 25mA$
DC V_{CC} or Ground Current, I_{CC} or I_{GND}	$\pm 50mA$

Thermal Information

Package Thermal Impedance, θ_{JA} (see Note 3):	
PDIP Package	67°C/W
SOIC Package	73°C/W
SOP Package	64°C/W
TSSOP Package	108°C/W
Maximum Junction Temperature	150°C
Maximum Storage Temperature Range	-65°C to 150°C
Maximum Lead Temperature (Soldering 10s)	300°C
(SOIC - Lead Tips Only)	

Operating Conditions

Temperature Range (T_A)	-55°C to 125°C
Supply Voltage Range, V_{CC}	
HC Types2V to 6V
HCT Types	4.5V to 5.5V
DC Input or Output Voltage, V_I , V_O	0V to V_{CC}
Input Rise and Fall Time	
2V	1000ns (Max)
4.5V	500ns (Max)
6V	400ns (Max)

CAUTION: Stresses above those listed in "Absolute Maximum Ratings" may cause permanent damage to the device. This is a stress only rating and operation of the device at these or any other conditions above those indicated in the operational sections of this specification is not implied.

NOTE:

- The package thermal impedance is calculated in accordance with JESD 51-7.

DC Electrical Specifications

PARAMETER	SYMBOL	TEST CONDITIONS		V_{CC} (V)	25°C			-40°C TO 85°C		-55°C TO 125°C		UNITS
		V_I (V)	I_O (mA)		MIN	TYP	MAX	MIN	MAX	MIN	MAX	
HC TYPES												
High Level Input Voltage	V_{IH}	-	-	2	1.5	-	-	1.5	-	1.5	-	V
				4.5	3.15	-	-	3.15	-	3.15	-	V
				6	4.2	-	-	4.2	-	4.2	-	V
Low Level Input Voltage	V_{IL}	-	-	2	-	-	0.5	-	0.5	-	0.5	V
				4.5	-	-	1.35	-	1.35	-	1.35	V
				6	-	-	1.8	-	1.8	-	1.8	V
High Level Output Voltage CMOS Loads	V_{OH}	V_{IH} or V_{IL}	-0.02	2	1.9	-	-	1.9	-	1.9	-	V
			-0.02	4.5	4.4	-	-	4.4	-	4.4	-	V
			-0.02	6	5.9	-	-	5.9	-	5.9	-	V
High Level Output Voltage TTL Loads	V_{OH}	V_{IH} or V_{IL}	-4	4.5	3.98	-	-	3.84	-	3.7	-	V
			-5.2	6	5.48	-	-	5.34	-	5.2	-	V
Low Level Output Voltage CMOS Loads	V_{OL}	V_{IH} or V_{IL}	0.02	2	-	-	0.1	-	0.1	-	0.1	V
			0.02	4.5	-	-	0.1	-	0.1	-	0.1	V
			0.02	6	-	-	0.1	-	0.1	-	0.1	V
Low Level Output Voltage TTL Loads	V_{OL}	V_{IH} or V_{IL}	4	4.5	-	-	0.26	-	0.33	-	0.4	V
			5.2	6	-	-	0.26	-	0.33	-	0.4	V

CD54/74HC194, CD74HCT194

DC Electrical Specifications (Continued)

PARAMETER	SYMBOL	TEST CONDITIONS		V _{CC} (V)	25°C			-40°C TO 85°C		-55°C TO 125°C		UNITS
		V _I (V)	I _O (mA)		MIN	TYP	MAX	MIN	MAX	MIN	MAX	
Input Leakage Current	I _I	V _{CC} or GND	-	6	-	-	±0.1	-	±1	-	±1	μA
Quiescent Device Current	I _{CC}	V _{CC} or GND	0	6	-	-	8	-	80	-	160	μA
HCT TYPES												
High Level Input Voltage	V _{IH}	-	-	4.5 to 5.5	2	-	-	2	-	2	-	V
Low Level Input Voltage	V _{IL}	-	-	4.5 to 5.5	-	-	0.8	-	0.8	-	0.8	V
High Level Output Voltage CMOS Loads	V _{OH}	V _{IH} or V _{IL}	-0.02	4.5	4.4	-	-	4.4	-	4.4	-	V
High Level Output Voltage TTL Loads			-4	4.5	3.98	-	-	3.84	-	3.7	-	V
Low Level Output Voltage CMOS Loads	V _{OL}	V _{IH} or V _{IL}	0.02	4.5	-	-	0.1	-	0.1	-	0.1	V
Low Level Output Voltage TTL Loads			4	4.5	-	-	0.26	-	0.33	-	0.4	V
Input Leakage Current	I _I	V _{CC} to GND	0	5.5	-	-	±0.1	-	±1	-	±1	μA
Quiescent Device Current	I _{CC}	V _{CC} or GND	0	5.5	-	-	8	-	80	-	160	μA
Additional Quiescent Device Current Per Input Pin: 1 Unit Load (Note 4)	ΔI _{CC}	V _{CC} -2.1	-	4.5 to 5.5	-	100	360	-	450	-	490	μA

NOTE:

- For dual-supply systems theoretical worst case (V_I = 2.4V, V_{CC} = 5.5V) specification is 1.8mA.

HCT Input Loading Table

INPUT	UNIT LOADS
CP	0.6
MR	0.55
DSL, DSR, D _n	0.25
Sn	1.10

NOTE: Unit Load is ΔI_{CC} limit specified in DC Electrical Specifications table, e.g. 360μA max at 25°C.

CD54/74HC194, CD74HCT194

Prerequisite For Switching Function

PARAMETER	SYMBOL	TEST CONDITIONS	V _{CC} (V)	25°C		-40°C TO 85°C		-55°C TO 125°C		UNITS
				MIN	MAX	MIN	MAX	MIN	MAX	
HC TYPES										
Max. Clock Frequency (Figure 1)	f _{MAX}	-	2	6	-	5	-	4	-	MHz
			4.5	30	-	24	-	20	-	MHz
			6	35	-	28	-	23	-	MHz
MR Pulse Width (Figure 2)	t _W	-	2	80	-	100	-	120	-	ns
			4.5	16	-	20	-	24	-	ns
			6	14	-	17	-	20	-	ns
Clock Pulse Width (Figure 1)	t _W	-	2	80	-	100	-	120	-	ns
			4.5	16	-	20	-	24	-	ns
			6	14	-	17	-	20	-	ns
Set-up Time Data to Clock (Figure 3)	t _{SU}	-	2	70	-	90	-	105	-	ns
			4.5	14	-	18	-	21	-	ns
			6	12	-	15	-	19	-	ns
Removal Time, MR to Clock (Figure 2)	t _{REM}	-	2	60	-	75	-	90	-	ns
			4.5	12	-	15	-	18	-	ns
			6	10	-	13	-	15	-	ns
Set-Up Time S1, S0 to Clock (Figure 4)	t _{SU}	-	2	80	-	100	-	120	-	ns
			4.5	16	-	20	-	24	-	ns
			6	14	-	17	-	20	-	ns
Set-up Time DSL, DSR to Clock (Figure 4)	t _{SU}	-	2	70	-	90	-	105	-	ns
			4.5	14	-	18	-	21	-	ns
			6	12	-	15	-	18	-	ns
Hold Time S1, S0 to Clock (Figure 4)	t _H	-	2	0	-	0	-	0	-	ns
			4.5	0	-	0	-	0	-	ns
			6	0	-	0	-	0	-	ns
Hold Time Data to Clock (Figure 3)	t _H	-	2	0	-	0	-	0	-	ns
			4.5	0	-	0	-	0	-	ns
			6	0	-	0	-	0	-	ns
HCT TYPES										
Max. Clock Frequency (Figure 1)	f _{MAX}	-	4.5	27	-	22	-	18	-	MHz
MR Pulse Width (Figure 2)	t _W	-	4.5	16	-	20	-	24	-	ns
Clock Pulse Width (Figure 1)	t _W	-	4.5	16	-	20	-	24	-	ns
Set-up Time, Data to Clock (Figure 3)	t _{SU}	-	4.5	14	-	18	-	21	-	ns
Removal Time MR to Clock (Figure 2)	t _{REM}	-	4.5	12	-	15	-	18	-	ns

Prerequisite For Switching Function (Continued)

PARAMETER	SYMBOL	TEST CONDITIONS	V _{CC} (V)	25°C		-40°C TO 85°C		-55°C TO 125°C		UNITS
				MIN	MAX	MIN	MAX	MIN	MAX	
Set-up Time S1, S0 to Clock (Figure 4)	t _{SU}	-	4.5	20	-	25	-	30	-	ns
Set-up Time DSL, DSR to Clock (Figure 4)	t _{SU}	-	4.5	14	-	18	-	21	-	ns
Hold Time S1, S0 to Clock (Figure 4)	t _H	-	4.5	0	-	0	-	0	-	ns
Hold Time Data to Clock (Figure 3)	t _H	-	4.5	0	-	0	-	0	-	ns

Switching Specifications Input t_r, t_f = 6ns

PARAMETER	SYMBOL	TEST CONDITIONS	V _{CC} (V)	25°C		-40°C TO 85°C	-55°C TO 125°C	UNITS
				TYP	MAX	MAX	MAX	
HC TYPES								
Propagation Delay, Clock to Output (Figure 1)	t _{PLH} , t _{PHL}	C _L = 50pF	2	-	175	220	265	ns
			4.5	-	35	44	53	ns
			6	-	30	37	45	ns
Propagation Delay, Clock to Q	t _{PLH} , t _{PHL}	-	5	14	-	-	-	ns
Output Transition Time (Figure 1)	t _{TLH} , t _{THL}	C _L = 50pF	2	-	75	95	110	ns
			4.5	-	15	19	22	ns
			6	-	13	16	19	ns
Propagation Delay, MR to Output (Figure 2)	t _{PHL}	C _L = 50pF	2	-	140	175	210	ns
			4.5	-	28	35	42	ns
			6	-	24	30	36	ns
Input Capacitance	C _{IN}	-	-	-	10	10	10	pF
Maximum Clock Frequency	f _{MAX}	-	5	60	-	-	-	MHz
Power Dissipation Capacitance (Notes 5, 6)	C _{PD}	-	5	55	-	-	-	pF
HCT TYPES								
Propagation Delay, Clock to Output (Figure 1)	t _{PLH} , t _{PHL}	C _L = 50pF	4.5	-	37	46	56	ns
Propagation Delay, Clock to Q	t _{PLH} , t _{PHL}	-	5	15	-	-	-	ns
Output Transition Times (Figure 1)	t _{TLH} , t _{THL}	C _L = 50pF	4.5	-	15	19	22	ns
Propagation Delay, MR to Output (Figure 2)	t _{PHL}	C _L = 50pF	4.5	-	40	50	60	ns
Input Capacitance	C _{IN}	-	-	-	10	10	10	pF
Maximum Clock Frequency	f _{MAX}	-	5	50	-	-	-	MHz
Power Dissipation Capacitance (Notes 5, 6)	C _{PD}	-	5	60	-	-	-	pF

NOTES:

- C_{PD} is used to determine the dynamic power consumption, per gate.
- $P_D = V_{CC}^2 f_i + \sum (C_L V_{CC}^2)$ where f_i = Input Frequency, C_L = Output Load Capacitance, V_{CC} = Supply Voltage.

Test Circuits and Waveforms

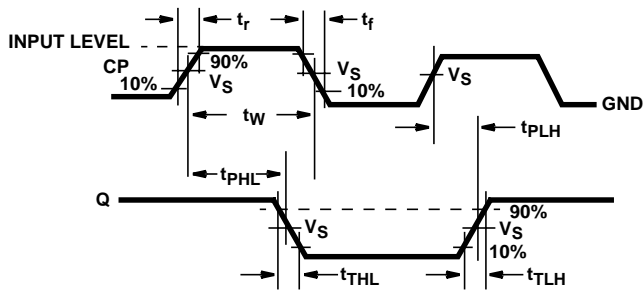

FIGURE 1. CLOCK PRE-REQUISITE TIMES AND PROPAGATION AND OUTPUT TRANSITION TIMES

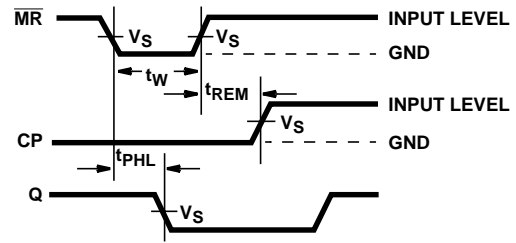

FIGURE 2. MASTER RESET PRE-REQUISITE TIMES AND PROPAGATION DELAYS

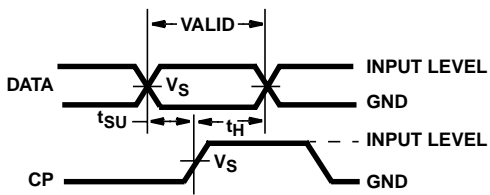

FIGURE 3. DATA PRE-REQUISITE TIMES

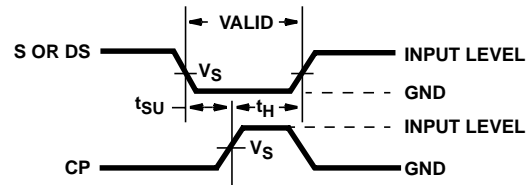

FIGURE 4. PARALLEL LOAD OR SHIFT-LEFT/SHIFT-RIGHT PRE-REQUISITE TIMES

IMPORTANT NOTICE

Texas Instruments Incorporated and its subsidiaries (TI) reserve the right to make corrections, modifications, enhancements, improvements, and other changes to its products and services at any time and to discontinue any product or service without notice. Customers should obtain the latest relevant information before placing orders and should verify that such information is current and complete. All products are sold subject to TI's terms and conditions of sale supplied at the time of order acknowledgment.

TI warrants performance of its hardware products to the specifications applicable at the time of sale in accordance with TI's standard warranty. Testing and other quality control techniques are used to the extent TI deems necessary to support this warranty. Except where mandated by government requirements, testing of all parameters of each product is not necessarily performed.

TI assumes no liability for applications assistance or customer product design. Customers are responsible for their products and applications using TI components. To minimize the risks associated with customer products and applications, customers should provide adequate design and operating safeguards.

TI does not warrant or represent that any license, either express or implied, is granted under any TI patent right, copyright, mask work right, or other TI intellectual property right relating to any combination, machine, or process in which TI products or services are used. Information published by TI regarding third-party products or services does not constitute a license from TI to use such products or services or a warranty or endorsement thereof. Use of such information may require a license from a third party under the patents or other intellectual property of the third party, or a license from TI under the patents or other intellectual property of TI.

Reproduction of information in TI data books or data sheets is permissible only if reproduction is without alteration and is accompanied by all associated warranties, conditions, limitations, and notices. Reproduction of this information with alteration is an unfair and deceptive business practice. TI is not responsible or liable for such altered documentation.

Resale of TI products or services with statements different from or beyond the parameters stated by TI for that product or service voids all express and any implied warranties for the associated TI product or service and is an unfair and deceptive business practice. TI is not responsible or liable for any such statements.

Mailing Address:

Texas Instruments
Post Office Box 655303
Dallas, Texas 75265