

CD54/74HC123, CD54/74HCT123, CD74HC423, CD74HCT423

High Speed CMOS Logic Dual Retriggerable Monostable Multivibrators with Resets

Features

- Overriding Reset Terminates Output Pulse
- Triggering From the Leading or Trailing Edge
- Q and \bar{Q} Buffered Outputs
- Separate Resets
- Wide Range of Output-Pulse Widths
- Schmitt Trigger on Both \bar{A} and B Inputs
- Fanout (Over Temperature Range)
 - Standard Outputs 10 LSTTL Loads
 - Bus Driver Outputs 15 LSTTL Loads
- Wide Operating Temperature Range . . . -55°C to 125°C
- Balanced Propagation Delay and Transition Times
- Significant Power Reduction Compared to LSTTL Logic ICs
- HC Types
 - 2V to 6V Operation
 - High Noise Immunity: $N_{IL} = 30\%$, $N_{IH} = 30\%$ of V_{CC} at $V_{CC} = 5V$
- HCT Types
 - 4.5V to 5.5V Operation
 - Direct LSTTL Input Logic Compatibility, $V_{IL} = 0.8V$ (Max), $V_{IH} = 2V$ (Min)
 - CMOS Input Compatibility, $I_I \leq 1\mu A$ at V_{OL} , V_{OH}

Pinout

CD54HC123, CD54HCT123
(CERDIP)
CD74HC123
(PDIP, SOIC, SOP)
CD74HCT123, CD74HC423, CD74HCT423
(PDIP, SOIC)
TOP VIEW

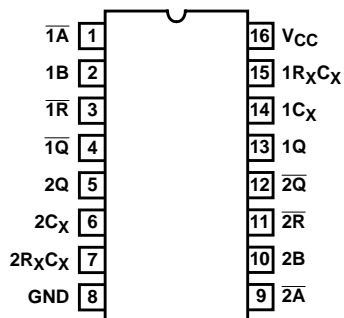

Description

The 'HC123, 'HCT123, CD74HC423 and CD74HCT423 are dual monostable multivibrators with resets. They are all retriggerable and differ only in that the 123 types can be triggered by a negative to positive reset pulse; whereas the 423 types do not have this feature. An external resistor (R_X) and an external capacitor (C_X) control the timing and the accuracy for the circuit. Adjustment of R_X and C_X provides a wide range of output pulse widths from the Q and \bar{Q} terminals. Pulse triggering on the \bar{A} and B inputs occur at a particular voltage level and is not related to the rise and fall times of the trigger pulses.

Once triggered, the output pulse width may be extended by retriggering inputs \bar{A} and B. The output pulse can be terminated by a LOW level on the Reset (R) pin. Trailing edge triggering (\bar{A}) and leading edge triggering (B) inputs are provided for triggering from either edge of the input pulse. If either Mono is not used each input on the unused device (\bar{A} , B, and \bar{R}) must be terminated high or low.

The minimum value of external resistance, R_X is typically 5k Ω . The minimum value external capacitance, C_X , is 0pF. The calculation for the pulse width is $t_W = 0.45 R_X C_X$ at $V_{CC} = 5V$.

Ordering Information

PART NUMBER	TEMP. RANGE (°C)	PACKAGE
CD54HC123F	-55 to 125	16 Ld CERDIP
CD54HC123F3A	-55 to 125	16 Ld CERDIP
CD74HC123E	-55 to 125	16 Ld PDIP
CD74HC123M	-55 to 125	16 Ld SOIC
CD74HC123NSR	-55 to 125	16 Ld SOP
CD54HCT123F3A	-55 to 125	16 Ld CERDIP
CD74HCT123E	-55 to 125	16 Ld PDIP
CD74HCT123M	-55 to 125	16 Ld SOIC
CD74HC423E	-55 to 125	16 Ld PDIP
CD74HC423M	-55 to 125	16 Ld SOIC
CD74HCT423E	-55 to 125	16 Ld PDIP
CD74HCT423M	-55 to 125	16 Ld SOIC

NOTES:

1. When ordering, use the entire part number. Add the suffix 96 to obtain the variant in the tape and reel.
2. Wafer or die for this part number is available which meets all electrical specifications. Please contact your local TI sales office or customer service for ordering information.

Functional Diagram

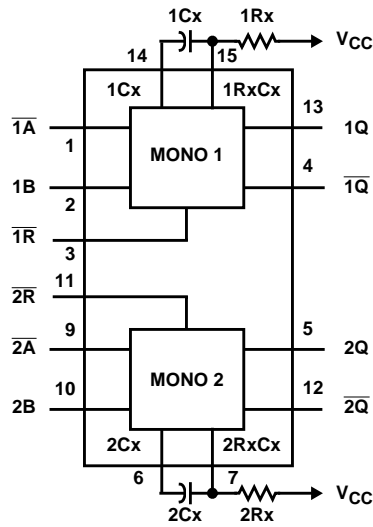

TRUTH TABLE

INPUTS			OUTPUTS	
\bar{A}	B	\bar{R}	Q	\bar{Q}
CD74HC/HCT123				
H	X	H	L	H
X	L	H	L	H
L	↑	H	⌋	⌋
↓	H	H	⌋	⌋
X	X	L	L	H
L	H	↑	⌋	⌋
CD74HC/HCT423				
H	X	H	L	H
X	L	H	L	H
L	↑	H	⌋	⌋
↓	H	H	⌋	⌋
X	X	L	L	H

NOTE: H = High Voltage Level, L = Low Voltage Level,
X = Don't Care.

CD54/74HC123, CD54/74HCT123, CD74HC423, CD74HCT423

Absolute Maximum Ratings

DC Supply Voltage, V_{CC}	-0.5V to 7V
DC Input Diode Current, I_{IK}	
For $V_I < -0.5V$ or $V_I > V_{CC} + 0.5V$	$\pm 20mA$
DC Output Diode Current, I_{OK}	
For $V_O < -0.5V$ or $V_O > V_{CC} + 0.5V$	$\pm 20mA$
DC Output Source or Sink Current per Output Pin, I_O	
For $V_O > -0.5V$ or $V_O < V_{CC} + 0.5V$	$\pm 25mA$
DC V_{CC} or Ground Current, I_{CC} or I_{GND}	$\pm 50mA$

Thermal Information

Package Thermal Impedance, θ_{JA} (see Note 3):	
PDIP Package	67°C/W
SOIC Package	73°C/W
SOP Package	64°C/W
Maximum Junction Temperature	150°C
Maximum Storage Temperature Range	-65°C to 150°C
Maximum Lead Temperature (Soldering 10s)	300°C
(SOIC - Lead Tips Only)	

Operating Conditions

Temperature Range (T_A)	-55°C to 125°C
Supply Voltage Range, V_{CC}	
HC Types2V to 6V
HCT Types4.5V to 5.5V
DC Input or Output Voltage, V_I, V_O	0V to V_{CC}
Input Rise and Fall Time	
2V	1000ns (Max)
4.5V	500ns (Max)
6V	400ns (Max)

CAUTION: Stresses above those listed in "Absolute Maximum Ratings" may cause permanent damage to the device. This is a stress only rating and operation of the device at these or any other conditions above those indicated in the operational sections of this specification is not implied.

NOTE:

- The package thermal impedance is calculated in accordance with JESD 51-7.

DC Electrical Specifications

PARAMETER	SYMBOL	TEST CONDITIONS		V_{CC} (V)	25°C			-40°C TO 85°C		-55°C TO 125°C		UNITS
		V_I (V)	I_O (mA)		MIN	TYP	MAX	MIN	MAX	MIN	MAX	
HC TYPES												
High Level Input Voltage	V_{IH}	-	-	2	1.5	-	-	1.5	-	1.5	-	V
				4.5	3.15	-	-	3.15	-	3.15	-	V
				6	4.2	-	-	4.2	-	4.2	-	V
Low Level Input Voltage	V_{IL}	-	-	2	-	-	0.5	-	0.5	-	0.5	V
				4.5	-	-	1.35	-	1.35	-	1.35	V
				6	-	-	1.8	-	1.8	-	1.8	V
High Level Output Voltage CMOS Loads	V_{OH}	V_{IH} or V_{IL}	-0.02	2	1.9	-	-	1.9	-	1.9	-	V
			-0.02	4.5	4.4	-	-	4.4	-	4.4	-	V
			-0.02	6	5.9	-	-	5.9	-	5.9	-	V
High Level Output Voltage TTL Loads	V_{OH}	V_{IH} or V_{IL}	-	-	-	-	-	-	-	-	-	V
			-4	4.5	3.98	-	-	3.84	-	3.7	-	V
			-5.2	6	5.48	-	-	5.34	-	5.2	-	V
Low Level Output Voltage CMOS Loads	V_{OL}	V_{IH} or V_{IL}	0.02	2	-	-	0.1	-	0.1	-	0.1	V
			0.02	4.5	-	-	0.1	-	0.1	-	0.1	V
			0.02	6	-	-	0.1	-	0.1	-	0.1	V
Low Level Output Voltage TTL Loads	V_{OL}	V_{IH} or V_{IL}	-	-	-	-	-	-	-	-	-	V
			4	4.5	-	-	0.26	-	0.33	-	0.4	V
			5.2	6	-	-	0.26	-	0.33	-	0.4	V
Input Leakage Current	I_I	V_{CC} or GND	-	6	-	-	± 0.1	-	± 1	-	± 1	μA
Quiescent Device Current	I_{CC}	V_{CC} or GND	0	6	-	-	8	-	80	-	160	μA

CD54/74HC123, CD54/74HCT123, CD74HC423, CD74HCT423

DC Electrical Specifications (Continued)

PARAMETER	SYMBOL	TEST CONDITIONS		V _{CC} (V)	25°C			-40°C TO 85°C		-55°C TO 125°C		UNITS
		V _I (V)	I _O (mA)		MIN	TYP	MAX	MIN	MAX	MIN	MAX	
HCT TYPES												
High Level Input Voltage	V _{IH}	-	-	4.5 to 5.5	2	-	-	2	-	2	-	V
Low Level Input Voltage	V _{IL}	-	-	4.5 to 5.5	-	-	0.8	-	0.8	-	0.8	V
High Level Output Voltage CMOS Loads	V _{OH}	V _{IH} or V _{IL}	-0.02	4.5	4.4	-	-	4.4	-	4.4	-	V
High Level Output Voltage TTL Loads			-4	4.5	3.98	-	-	3.84	-	3.7	-	V
Low Level Output Voltage CMOS Loads	V _{OL}	V _{IH} or V _{IL}	0.02	4.5	-	-	0.1	-	0.1	-	0.1	V
Low Level Output Voltage TTL Loads			4	4.5	-	-	0.26	-	0.33	-	0.4	V
Input Leakage Current	I _I	V _{CC} and GND	0	5.5	-	-	±0.1	-	±1	-	±1	μA
Quiescent Device Current	I _{CC}	V _{CC} or GND	0	5.5	-	-	8	-	80	-	160	μA
Additional Quiescent Device Current Per Input Pin: 1 Unit Load	ΔI _{CC}	V _{CC} -2.1	-	4.5 to 5.5	-	100	360	-	450	-	490	μA

NOTE: For dual-supply systems theoretical worst case (V_I = 2.4V, V_{CC} = 5.5V) specification is 1.8mA.

HCT Input Loading Table

INPUT	UNIT LOADS
All	0.35

NOTE: Unit Load is ΔI_{CC} limit specified in DC Electrical Table, e.g. 360μA max at 25°C.

Prerequisite for Switching Specifications

PARAMETER	SYMBOL	V _{CC} (V)	25°C			-40°C TO 85°C			-55°C TO 125°C			UNITS
			MIN	TYP	MAX	MIN	TYP	MAX	MIN	TYP	MAX	
HC TYPES												
Minimum Input, Pulse Width A	t _{WL}	2	100	-	-	125	-	-	150	-	-	ns
		4.5	20	-	-	25	-	-	30	-	-	ns
		6	17	-	-	21	-	-	26	-	-	ns
B	t _{WH}	2	100	-	-	125	-	-	150	-	-	ns
		4.5	20	-	-	25	-	-	30	-	-	ns
		6	17	-	-	21	-	-	26	-	-	ns

CD54/74HC123, CD54/74HCT123, CD74HC423, CD74HCT423

Prerequisite for Switching Specifications (Continued)

PARAMETER	SYMBOL	V _{CC} (V)	25°C			-40°C TO 85°C			-55°C TO 125°C			UNITS
			MIN	TYP	MAX	MIN	TYP	MAX	MIN	TYP	MAX	
\bar{R}	t _{WL}	2	100	-	-	125	-	-	150	-	150	ns
		4.5	20	-	-	25	-	-	30	-	30	ns
		6	17	-	-	21	-	-	26	-	26	ns
\bar{A} and B Hold Time	t _H	2	50	-	-	65	-	-	75	-	75	ns
		4.5	10	-	-	13	-	-	15	-	15	ns
		6	9	-	-	11	-	-	13	-	13	ns
Reset Removal Time	t _{REM}	2	50	-	-	65	-	-	75	-	75	ns
		4.5	10	-	-	13	-	-	15	-	15	ns
		6	9	-	-	11	-	-	13	-	13	ns
Retrigger Time Number R _X = 10KΩ, C _X = 0	t _{rT}	5	-	-	-	-	-	-	-	-	-	ns
			-	50	-	-	63	-	-	76	-	ns
Output Pulse Width Q or \bar{Q} R _X = 10KΩ, C _X = 10nF	t _W	5	40	-	50	38.7	-	51.3	38.2	-	51.8	μs
HCT TYPES												
Minimum Input, Pulse Width \bar{A}	t _{WL}	5	20	-	-	25	-	-	30	-	-	ns
B	t _{WH}		20	-	-	25	-	-	30	-	-	ns
\bar{R}	t _{WL}		20	-	-	25	-	-	30	-	-	ns
\bar{A} and B Hold Time	t _H	5	10	-	-	13	-	-	15	-	-	ns
Reset Removal Time	t _{REM}	5	10	-	-	13	-	-	15	-	-	ns
Retrigger Time Number (Note 4) R _X = 10KΩ, C _X = 0	t _{rT}	5	-	50	-	-	63	-	-	76	-	ns
Output Pulse Width Q or \bar{Q} R _X = 10KΩ, C _X = 10nF	t _W	5	40	-	50	38.7	-	51.3	38.2	-	51.8	μs

NOTE:

- Time to trigger depends on the values of R_X and C_X. The output pulse width can only be extended when the time between the active-going edges of the trigger input pulses meet the minimum retrigger time requirement.

CD54/74HC123, CD54/74HCT123, CD74HC423, CD74HCT423

Switching Specifications $C_L = 50\text{pF}$, Input $t_r, t_f = 6\text{ns}$, $R_X = 10\text{K}\Omega$, $C_X = 0$

PARAMETER	SYMBOL	TEST CONDITIONS	V_{CC} (V)	25°C			-40°C TO 85°C		-55°C TO 125°C		UNITS
				MIN	TYP	MAX	MIN	MAX	MIN	MAX	
HC TYPES											
Trigger Propagation Delay \bar{A}, B, \bar{R} to Q	t_{PHL}	$C_L = 50\text{pF}$	2	-	-	300	-	375	-	450	ns
			4.5	-	-	60	-	75	-	90	ns
		$C_L = 15\text{pF}$	5	-	25	-	-	-	-	-	ns
		$C_L = 50\text{pF}$	6	-	-	51	-	64	-	76	ns
\bar{A}, B, \bar{R} to \bar{Q}	t_{PHL}	$C_L = 50\text{pF}$	2	-	-	320	-	400	-	480	ns
			4.5	-	-	64	-	80	-	96	ns
		$C_L = 15\text{pF}$	5	-	26	-	-	-	-	-	ns
		$C_L = 50\text{pF}$	6	-	-	54	-	68	-	82	ns
Reset Propagation Delay \bar{R} to Q or \bar{Q}	t_{PHL}, t_{PLH}	$C_L = 50\text{pF}$	2	-	-	215	-	270	-	325	ns
			4.5	-	-	43	-	54	-	65	ns
			6	-	-	37	-	46	-	55	ns
Output Transition Time	t_{THL}, t_{TLH}	$C_L = 50\text{pF}$	2	-	-	75	-	95	-	110	ns
			4.5	-	-	15	-	19	-	22	ns
			6	-	-	13	-	16	-	19	ns
Output Pulse Width $R_X = 10\text{K}\Omega, C_X = 10\text{pF}$	-	-	5	-	45	-	-	-	-	μs	
Pulse Width Match Between Circuits In the Same Package $R_X = 10\text{K}\Omega, C_X = 10\text{pF}$	-	-	5	-	± 2	-	-	-	-	%	
Power Dissipation Capacitance (Notes 5, 6)	C_{PD}	$C_L = 15\text{pF}$	5	-	-	-	-	-	-	-	pF
Input Capacitance	C_{IN}	$C_L = 50\text{pF}$	-	10	-	10	-	10	-	10	pF

NOTES:

- C_{PD} is used to determine the dynamic power consumption, per multivibrator.
- $P_D = (C_{PD} + C_X) V_{CC}^2 f_i \sum (C_L V_{CC}^2 f_O)$ where f_i = input frequency, f_O = Output Frequency, C_L = Output Load Capacitance, C_X = External Capacitance V_{CC} = Supply Voltage assuming $f_i \ll \frac{1}{t_W}$

Test Circuits and Waveforms

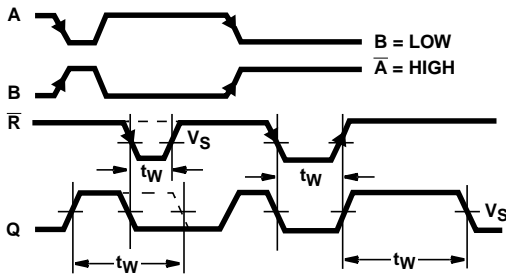

FIGURE 1. OUTPUT PULSE CONTROL USING RESET INPUT (\bar{R}) PULSE FOR 123

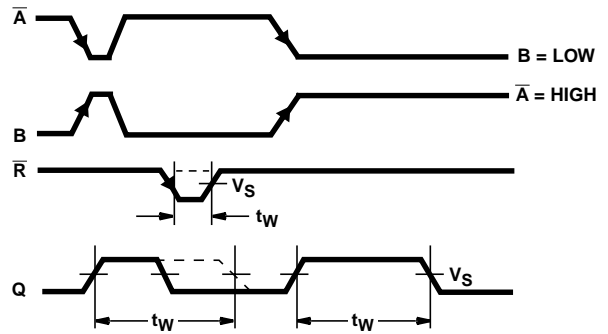
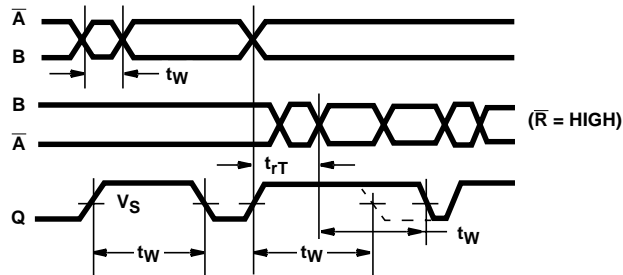

FIGURE 2. OUTPUT PULSE CONTROL USING RESET INPUT (\bar{R}) FOR 423



NOTE: Output pulse control using retrigger pulse for 123 and 423.

FIGURE 3. TRIGGERING OF ONE SHOT BY INPUT \bar{A} OR INPUT B FOR A PERIOD t_W

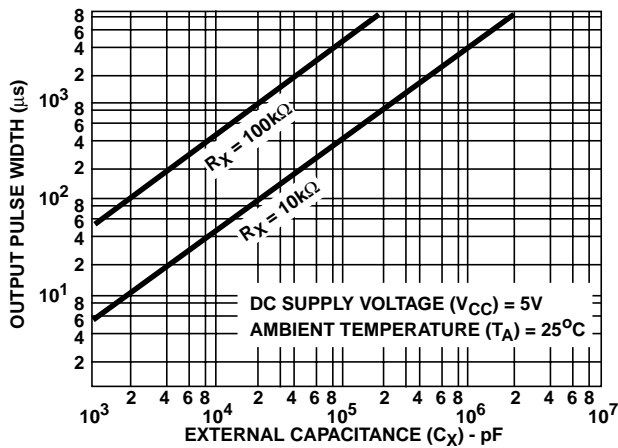

FIGURE 4. TYPICAL OUTPUT PULSE WIDTH AS A FUNCTION OF C_X FOR $R_X = 10k\Omega$ AND $100k\Omega$

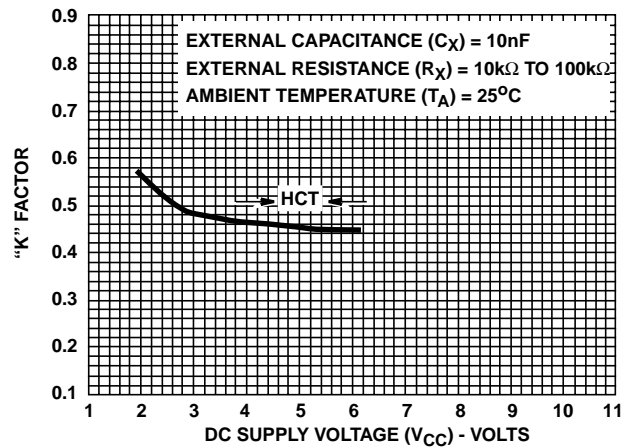

FIGURE 5. TYPICAL "K" FACTOR AS A FUNCTION OF V_{CC}

IMPORTANT NOTICE

Texas Instruments Incorporated and its subsidiaries (TI) reserve the right to make corrections, modifications, enhancements, improvements, and other changes to its products and services at any time and to discontinue any product or service without notice. Customers should obtain the latest relevant information before placing orders and should verify that such information is current and complete. All products are sold subject to TI's terms and conditions of sale supplied at the time of order acknowledgment.

TI warrants performance of its hardware products to the specifications applicable at the time of sale in accordance with TI's standard warranty. Testing and other quality control techniques are used to the extent TI deems necessary to support this warranty. Except where mandated by government requirements, testing of all parameters of each product is not necessarily performed.

TI assumes no liability for applications assistance or customer product design. Customers are responsible for their products and applications using TI components. To minimize the risks associated with customer products and applications, customers should provide adequate design and operating safeguards.

TI does not warrant or represent that any license, either express or implied, is granted under any TI patent right, copyright, mask work right, or other TI intellectual property right relating to any combination, machine, or process in which TI products or services are used. Information published by TI regarding third-party products or services does not constitute a license from TI to use such products or services or a warranty or endorsement thereof. Use of such information may require a license from a third party under the patents or other intellectual property of the third party, or a license from TI under the patents or other intellectual property of TI.

Reproduction of information in TI data books or data sheets is permissible only if reproduction is without alteration and is accompanied by all associated warranties, conditions, limitations, and notices. Reproduction of this information with alteration is an unfair and deceptive business practice. TI is not responsible or liable for such altered documentation.

Resale of TI products or services with statements different from or beyond the parameters stated by TI for that product or service voids all express and any implied warranties for the associated TI product or service and is an unfair and deceptive business practice. TI is not responsible or liable for any such statements.

Mailing Address:

Texas Instruments
Post Office Box 655303
Dallas, Texas 75265