



12-BIT 250-KSPS SAMPLING CMOS ANALOG-TO-DIGITAL CONVERTER

FEATURES

- 250-kHz Sampling Rate
- Standard ± 10 -V Input Range
- 73-dB SINAD With 45-kHz Input
- ± 0.45 LSB Max INL
- ± 0.45 LSB Max DNL
- 12 Bit No Missing Code
- ± 1 LSB Bipolar Zero Errors
- ± 0.4 PPM/ $^{\circ}$ C Bipolar Zero Error Drift
- Single 5-V Supply Operation
- Pin-Compatible With ADS7804/05 (Low Speed) and 16-Bit ADS8505
- Uses Internal or External Reference
- Full Parallel Data Output
- 70-mW Typ Power Dissipation at 250 KSPS
- 28-Pin SOIC Package

APPLICATIONS

- Industrial Process Control
- Data Acquisition Systems
- Digital Signal Processing
- Medical Equipment
- Instrumentation

DESCRIPTION

The ADS8504 is a complete 12-bit sampling A/D converter using state-of-the-art CMOS structures. It contains a complete 12-bit, capacitor-based, SAR A/D with S/H, reference, clock, interface for microprocessor use, and 3-state output drivers.

The ADS8504 is specified at a 250-kHz sampling rate over the full temperature range. Precision resistors provide an industry standard ± 10 -V input range, while the innovative design allows operation from a single +5-V supply, with power dissipation under 100 mW.

The ADS8504 is available in a 28-pin SOIC package and is fully specified for operation over the industrial -40° C to 85° C temperature range.

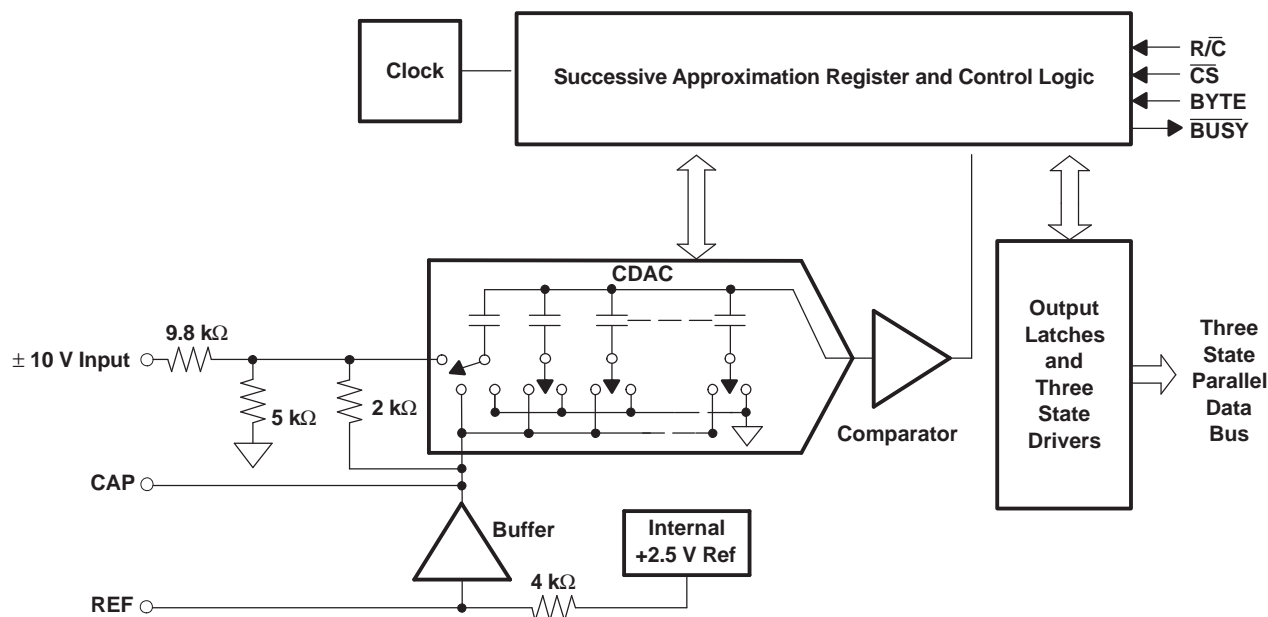

Please be aware that an important notice concerning availability, standard warranty, and use in critical applications of Texas Instruments semiconductor products and disclaimers thereto appears at the end of this data sheet.



These devices have limited built-in ESD protection. The leads should be shorted together or the device placed in conductive foam during storage or handling to prevent electrostatic damage to the MOS gates.

PACKAGE/ORDERING INFORMATION⁽¹⁾

| PRODUCT | MINIMUM RELATIVE ACCURACY (LSB) | NO MISSING CODE | MINIMUM SINAD (dB) | SPECIFICATION TEMPERATURE RANGE | PACKAGE LEAD | PACKAGE DESIGNATOR | ORDERING NUMBER | TRANSPORT MEDIA, QTY |
|-----------|---------------------------------|-----------------|--------------------|---------------------------------|--------------|--------------------|-----------------|----------------------|
| ADS8504IB | ±0.45 | 12 | 72 | -40°C to 85°C | SO-28 | DW | ADS8504IBDW | Tube, 20 |
| | | | | | | | ADS8504IBDWR | Tape and Reel, 1000 |

(1) For the most current package and ordering information, see the Package Option Addendum at the end of this document, or see the TI web site at www.ti.com.

ABSOLUTE MAXIMUM RATINGS⁽¹⁾

over operating free-air temperature range (unless otherwise noted)⁽²⁾

| | | ADS8504 |
|---|--------------------------------------|--|
| Analog inputs | V _{IN} | ±25V |
| | CAP | +V _{ANA} + 0.3 V to AGND2 - 0.3 V |
| | REF | Indefinite short to AGND2, momentary short to V _{ANA} |
| Ground voltage differences | DGND, AGND1, AGND2 | ±0.3 V |
| | V _{ANA} | 6 V |
| | V _{DIG} to V _{ANA} | 0.3 V |
| | V _{DIG} | 6 V |
| Digital inputs | | -0.3 V to +V _{DIG} + 0.3 V |
| Maximum junction temperature | | 165°C |
| Internal power dissipation | | 825 mW |
| Lead temperature (soldering, 1,6mm from case, 10 seconds) | | 260°C |

(1) Stresses beyond those listed under "absolute maximum ratings" may cause permanent damage to the device. These are stress ratings only, and functional operation of the device at these or any other conditions beyond those indicated under "recommended operating conditions" is not implied. Exposure to absolute-maximum-rated conditions for extended periods may affect device reliability.

(2) All voltage values are with respect to network ground terminal.

ELECTRICAL CHARACTERISTICS

T_A = -40°C to 85°C, f_s = 250 kHz, V_{DIG} = V_{ANA} = 5 V, using internal reference (unless otherwise noted)

| PARAMETER | | TEST CONDITIONS | MIN | TYP | MAX | UNIT |
|---------------------------------|------------------------------|---------------------|-------|------|------|--------------------|
| Resolution | | | | | 12 | Bits |
| ANALOG INPUT | | | | | | |
| Voltage range | | | | ±10 | | V |
| Impedance | | | | 11.5 | | kΩ |
| Capacitance | | | | 50 | | pF |
| THROUGHPUT SPEED | | | | | | |
| Conversion cycle | | Acquire and convert | | | 4 | μs |
| Throughput rate | | | 250 | | | kHz |
| DC ACCURACY | | | | | | |
| INL | Integral linearity error | | -0.45 | | 0.45 | LSB ⁽¹⁾ |
| DNL | Differential linearity error | | -0.45 | | 0.45 | LSB ⁽¹⁾ |
| No missing codes | | | 12 | | | Bits |
| Transition noise ⁽²⁾ | | | | 0.1 | | LSB |

(1) LSB means least significant bit. For the 12-bit, ±10-V input ADS8504, one LSB is 4.88 mV.

(2) Typical rms noise at worst case transitions and temperatures.

ELECTRICAL CHARACTERISTICS (continued)
 $T_A = -40^{\circ}\text{C}$ to 85°C , $f_s = 250\text{ kHz}$, $V_{\text{DIG}} = V_{\text{ANA}} = 5\text{ V}$, using internal reference (unless otherwise noted)

| PARAMETER | | TEST CONDITIONS | MIN | TYP | MAX | UNIT |
|--------------------------|--|---|-------|---------------------------------|------|-------------------|
| | Full-scale error ⁽³⁾⁽⁴⁾ | Int. Ref. | -0.25 | | 0.25 | %FSR |
| | Full-scale error drift | Int. Ref. | | ±7 | | ppm/°C |
| | Full-scale error ⁽³⁾⁽⁴⁾ | Ext. 2.5-V Ref. | -0.25 | | 0.25 | %FSR |
| | Full-scale error drift | Ext. 2.5-V Ref. | | ±2 | | ppm/°C |
| | Bipolar zero error ⁽³⁾ | | -1 | | 1 | LSB |
| | Bipolar zero error drift | | | ±0.4 | | ppm/°C |
| | Power supply sensitivity ($V_{\text{DIG}} = V_{\text{ANA}} = V_{\text{D}}$) | +4.75 V < V_{D} < +5.25 V | -0.5 | | 0.5 | LSB |
| AC ACCURACY | | | | | | |
| SFDR | Spurious-free dynamic range | $f_1 = 45\text{ kHz}$ | 86 | 94 | | dB ⁽⁵⁾ |
| THD | Total harmonic distortion | $f_1 = 45\text{ kHz}$ | | -95 | -86 | dB |
| SINAD | Signal-to-(noise+distortion) | $f_1 = 45\text{ kHz}$ | 72 | 73 | | dB |
| | | -60-dB Input | | 32 | | dB |
| SNR | Signal-to-noise ratio | $f_1 = 45\text{ kHz}$ | 72 | 73 | | dB |
| | Full-power bandwidth ⁽⁶⁾ | | | 500 | | kHz |
| SAMPLING DYNAMICS | | | | | | |
| | Aperture delay | | | 5 | | ns |
| | Transient response | FS Step | | | 2 | µs |
| | Overvoltage recovery ⁽⁷⁾ | | | 150 | | ns |
| REFERENCE | | | | | | |
| | Internal reference voltage | | 2.48 | 2.5 | 2.52 | V |
| | Internal reference source current (must use external buffer) | | | 1 | | µA |
| | Internal reference drift | | | 8 | | ppm/°C |
| | External reference voltage range for specified linearity | | 2.3 | 2.5 | 2.7 | V |
| | External reference current drain | Ext. 2.5-V Ref. | | | 100 | µA |
| DIGITAL INPUTS | | | | | | |
| | Logic levels | | | | | |
| V_{IL} | Low-level input voltage | | -0.3 | | 0.8 | V |
| V_{IH} | High-level input voltage | | 2.0 | $V_{\text{DIG}} + 0.3\text{ V}$ | | V |
| I_{IL} | Low-level input current | | | | ±10 | µA |
| I_{IH} | High-level input current | | | | ±10 | µA |
| DIGITAL OUTPUTS | | | | | | |
| | Data format (Parallel 12-bits) | | | | | |
| | Data coding (Binary 2's complement) | | | | | |
| V_{OL} | Low-level output voltage | $I_{\text{SINK}} = 1.6\text{ mA}$ | | | 0.4 | V |
| V_{OH} | High-level output voltage | $I_{\text{SOURCE}} = 500\text{ µA}$ | 4 | | | V |
| | Leakage current | Hi-Z state, $V_{\text{OUT}} = 0\text{ V}$ to V_{DIG} | | | ±5 | µA |
| | Output capacitance | Hi-Z state | | | 15 | pF |
| DIGITAL TIMING | | | | | | |
| | Bus access timing | | | | 83 | ns |

(3) As measured with fixed resistors shown in [Figure 24](#). Adjustable to zero with external potentiometer.

(4) Full-scale error is the worst case of -full-scale or +full-scale deviation from ideal first and last code transitions, divided by the transition voltage (not divided by the full-scale range) and includes the effect of offset error.

(5) All specifications in dB are referred to a full-scale ±10-V input.

(6) Full-power bandwidth is defined as the full-scale input frequency at which signal-to-(noise + distortion) degrades to 60 dB, or 10 bits of accuracy.

(7) Recovers to specified performance after 2 x FS input overvoltage.

ELECTRICAL CHARACTERISTICS (continued)

$T_A = -40^{\circ}\text{C}$ to 85°C , $f_s = 250\text{ kHz}$, $V_{\text{DIG}} = V_{\text{ANA}} = 5\text{ V}$, using internal reference (unless otherwise noted)

| PARAMETER | | TEST CONDITIONS | MIN | TYP | MAX | UNIT |
|---|-----------------------|-------------------------------|------|-----|------|-----------------------------|
| Bus relinquish timing | | | | | 83 | ns |
| POWER SUPPLIES | | | | | | |
| V_{DIG} | Digital input voltage | Must be $\leq V_{\text{ANA}}$ | 4.75 | 5 | 5.25 | V |
| V_{ANA} | Analog input voltage | | 4.75 | 5 | 5.25 | V |
| I_{DIG} | Digital input current | | | 4 | | mA |
| I_{ANA} | Analog input current | | | 10 | | mA |
| Power dissipation | | $f_s = 250\text{ kHz}$ | | 70 | 100 | mW |
| TEMPERATURE RANGE | | | | | | |
| Specified performance | | | -40 | | 85 | $^{\circ}\text{C}$ |
| Derated performance ⁽⁸⁾ | | | -55 | | 125 | $^{\circ}\text{C}$ |
| Storage | | | -65 | | 150 | $^{\circ}\text{C}$ |
| THERMAL RESISTANCE (θ_{JA}) | | | | | | |
| SO | | | | 46 | | $^{\circ}\text{C}/\text{W}$ |

(8) The internal reference may not be started correctly beyond the industrial temperature range (-40°C to 85°C), therefore use of an external reference is recommended.

DEVICE INFORMATION

**DW PACKAGE
(TOP VIEW)**

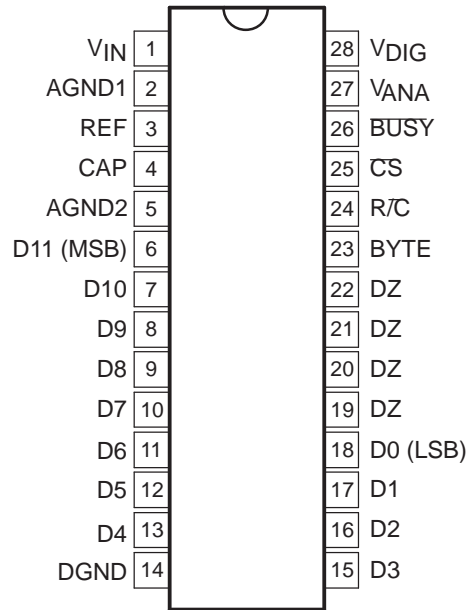

DEVICE INFORMATION (continued)
Terminal Functions

| TERMINAL | | DIGITAL I/O | DESCRIPTION |
|--------------------------|--------|----------------|---|
| NAME | DW NO. | | |
| AGND1 | 2 | | Analog ground. Used internally as ground reference point. |
| AGND2 | 5 | | Analog ground. |
| $\overline{\text{BUSY}}$ | 26 | O | At the start of a conversion, $\overline{\text{BUSY}}$ goes low and stays low until the conversion is completed and the digital outputs have been updated. |
| BYTE | 23 | I | Selects 8 most significant bits (low) or 8 least significant bits (high). |
| CAP | 4 | | Reference buffer capacitor. 2.2- μF tantalum capacitor to ground. |
| $\overline{\text{CS}}$ | 25 | I | Internally ORed with R/ $\overline{\text{C}}$. If R/ $\overline{\text{C}}$ low, a falling edge on $\overline{\text{CS}}$ initiates a new conversion. |
| DGND | 14 | | Digital ground. |
| D11 (MSB) | 6 | O | Data bit 11. Most significant bit (MSB) of conversion results. Hi-Z state when $\overline{\text{CS}}$ is high, or when R/ $\overline{\text{C}}$ is low. |
| D10 | 7 | O | Data bit 10. Hi-Z state when $\overline{\text{CS}}$ is high, or when R/ $\overline{\text{C}}$ is low. |
| D9 | 8 | O | Data bit 9. Hi-Z state when $\overline{\text{CS}}$ is high, or when R/ $\overline{\text{C}}$ is low. |
| D8 | 9 | O | Data bit 8. Hi-Z state when $\overline{\text{CS}}$ is high, or when R/ $\overline{\text{C}}$ is low. |
| D7 | 10 | O | Data bit 7. Hi-Z state when $\overline{\text{CS}}$ is high, or when R/ $\overline{\text{C}}$ is low. |
| D6 | 11 | O | Data bit 6. Hi-Z state when $\overline{\text{CS}}$ is high, or when R/ $\overline{\text{C}}$ is low. |
| D5 | 12 | O | Data bit 5. Hi-Z state when $\overline{\text{CS}}$ is high, or when R/ $\overline{\text{C}}$ is low. |
| D4 | 13 | O | Data bit 4. Hi-Z state when $\overline{\text{CS}}$ is high, or when R/ $\overline{\text{C}}$ is low. |
| D3 | 15 | O | Data bit 3. Hi-Z state when $\overline{\text{CS}}$ is high, or when R/ $\overline{\text{C}}$ is low. |
| D2 | 16 | O | Data bit 2. Hi-Z state when $\overline{\text{CS}}$ is high, or when R/ $\overline{\text{C}}$ is low. |
| D1 | 17 | O | Data bit 1. Hi-Z state when $\overline{\text{CS}}$ is high, or when R/ $\overline{\text{C}}$ is low. |
| D0 (LSB) | 18 | O | Data bit 0. Least significant bit (LSB) of conversion results. Hi-Z state when $\overline{\text{CS}}$ is high, or when R/ $\overline{\text{C}}$ is low. |
| DZ | 19 | O | Low when $\overline{\text{CS}}$ low, R/ $\overline{\text{C}}$ high. Hi-Z state when $\overline{\text{CS}}$ is high, or when R/ $\overline{\text{C}}$ is low. |
| DZ | 20 | O | Low when $\overline{\text{CS}}$ low, R/ $\overline{\text{C}}$ high. Hi-Z state when $\overline{\text{CS}}$ is high, or when R/ $\overline{\text{C}}$ is low. |
| DZ | 21 | O | Low when $\overline{\text{CS}}$ low, R/ $\overline{\text{C}}$ high. Hi-Z state when $\overline{\text{CS}}$ is high, or when R/ $\overline{\text{C}}$ is low. |
| DZ | 22 | O | Low when $\overline{\text{CS}}$ low, R/ $\overline{\text{C}}$ high. Hi-Z state when $\overline{\text{CS}}$ is high, or when R/ $\overline{\text{C}}$ is low. |
| R/ $\overline{\text{C}}$ | 24 | I | With $\overline{\text{CS}}$ low and $\overline{\text{BUSY}}$ high, a falling edge on R/ $\overline{\text{C}}$ initiates a new conversion. With $\overline{\text{CS}}$ low, a rising edge on R/ $\overline{\text{C}}$ enables the parallel output. |
| REF | 3 | | Reference input/output. 2.2- μF tantalum capacitor to ground. |
| V _{ANA} | 27 | | Analog supply input. Nominally +5 V. Decouple to ground with 0.1- μF ceramic and 10- μF tantalum capacitors. |
| V _{DIG} | 28 | | Digital supply input. Nominally +5 V. Connect directly to pin 27. Must be $\leq V_{\text{ANA}}$. |
| V _{IN} | 1 | | Analog input. |

Typical Characteristics

SPURIOUS FREE DYNAMIC RANGE
VS
FREE-AIR TEMPERATURE

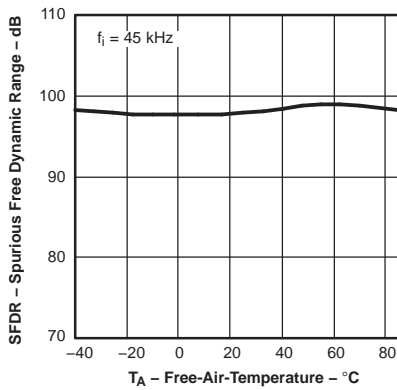

Figure 1.

TOTAL HARMONIC DISTORTION
VS
FREE-AIR TEMPERATURE

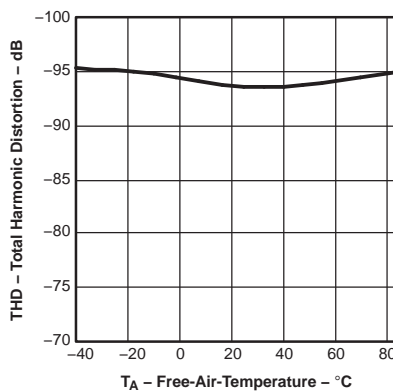

Figure 2.

SIGNAL-TO-NOISE RATIO
VS
FREE-AIR TEMPERATURE

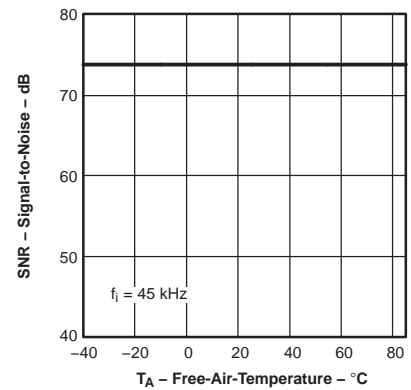

Figure 3.

SIGNAL-TO-NOISE AND DISTORTION
VS
FREE-AIR TEMPERATURE

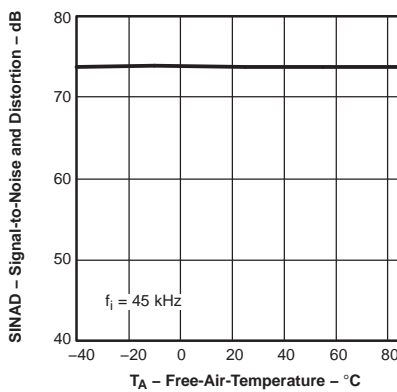

Figure 4.

SIGNAL-TO-NOISE RATIO
VS
INPUT FREQUENCY

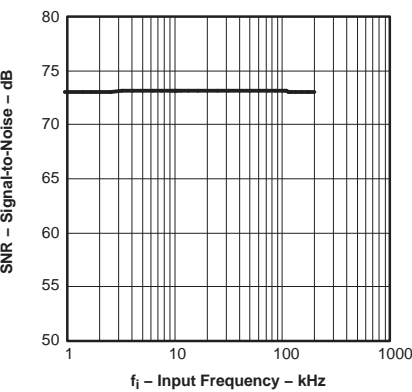

Figure 5.

SIGNAL-TO-NOISE AND DISTORTION
VS
INPUT FREQUENCY

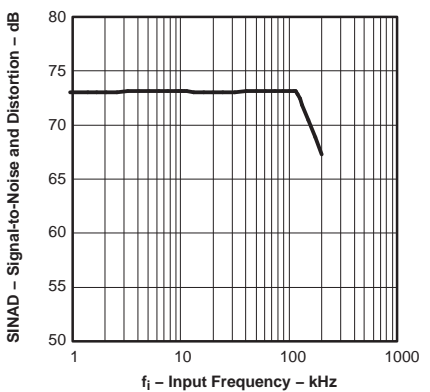

Figure 6.

SPURIOUS FREE DYNAMIC RANGE
VS
INPUT FREQUENCY

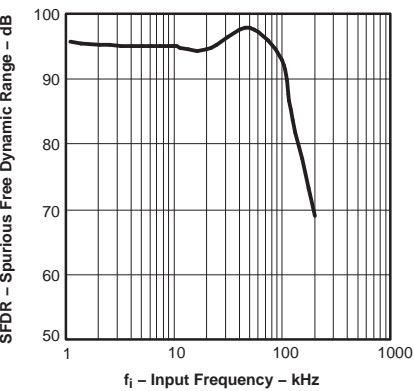

Figure 7.

TOTAL HARMONIC DISTORTION
VS
INPUT FREQUENCY

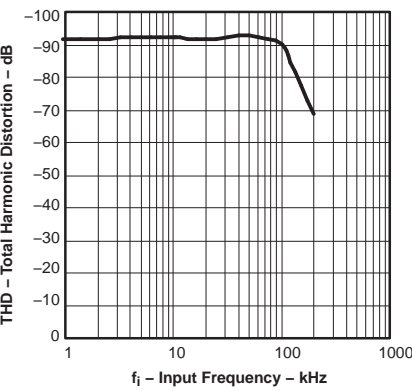

Figure 8.

BIPOLAR ZERO ERROR
VS
FREE-AIR TEMPERATURE

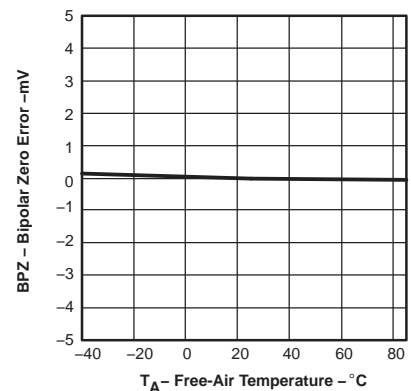

Figure 9.

Typical Characteristics (continued)

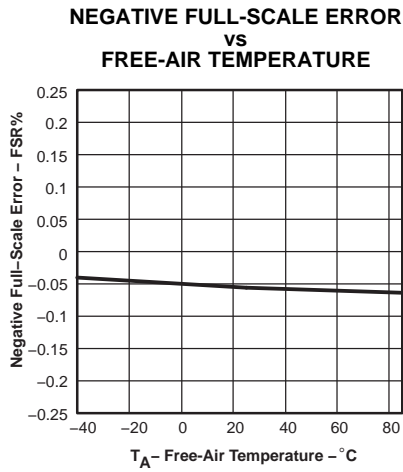

Figure 10.

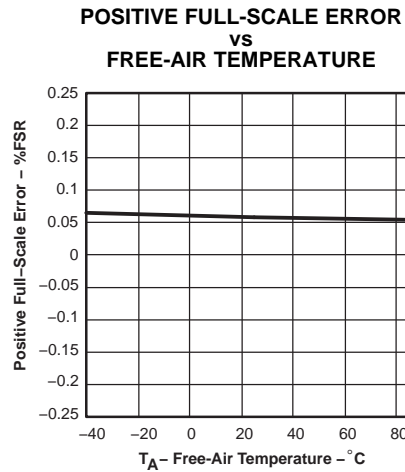

Figure 11.

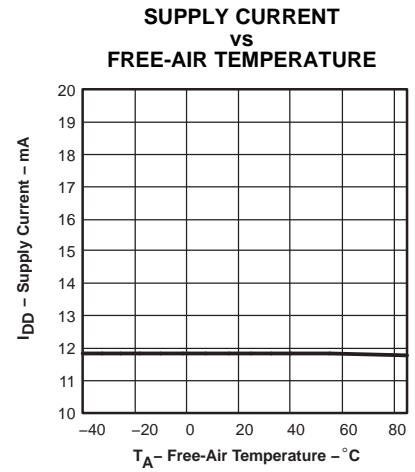

Figure 12.

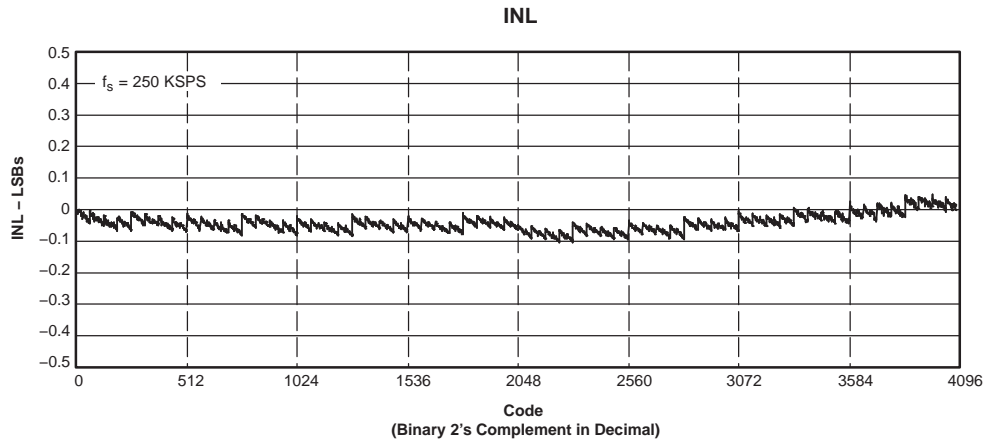

Figure 13.

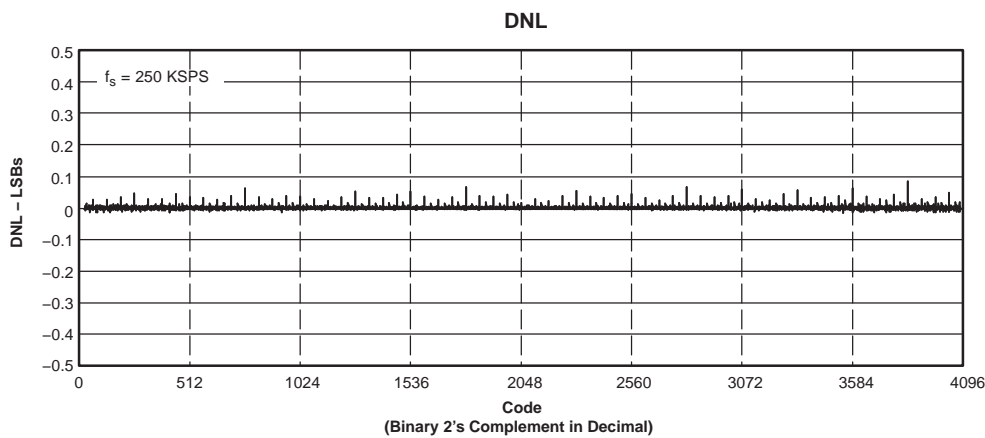

Figure 14.

Typical Characteristics (continued)

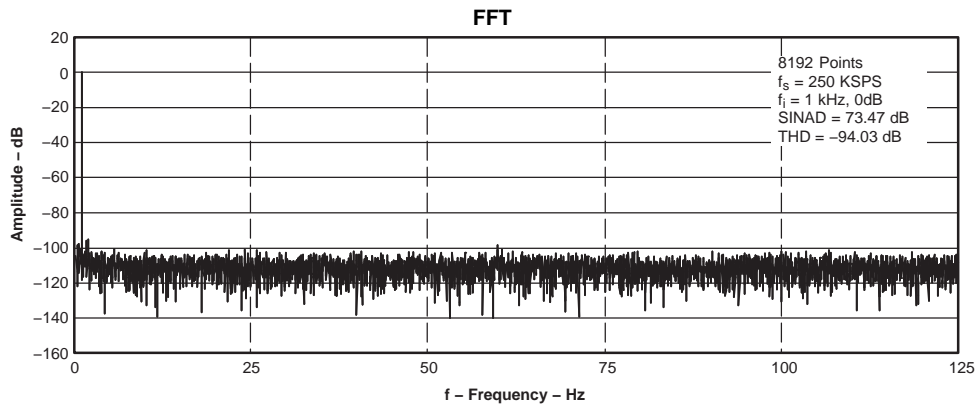

Figure 15.

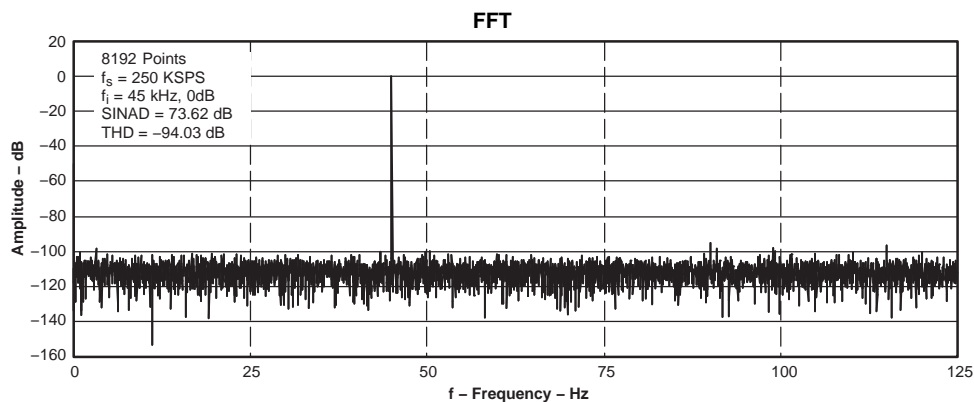

Figure 16.

BASIC OPERATION

Figure 17 shows a basic circuit to operate the ADS8504 with a full parallel data output. Taking $\overline{R/C}$ (pin 24) low for a minimum of 40 ns (1.75 μ s max if \overline{BUSY} is used to latch the data) initiates a conversion. \overline{BUSY} (pin 26) goes low and stays low until the conversion is completed and the output registers are updated. Data is output in binary 2's complement with the MSB on pin 6. \overline{BUSY} going high can be used to latch the data.

The ADS8504 begins tracking the input signal at the end of the conversion. Allowing 4 μ s between convert commands assures accurate acquisition of a new signal.

The offset and gain are adjusted internally to allow external trimming with a single supply. The external resistors compensate for this adjustment and can be left out if the offset and gain are corrected in software (refer to the Calibration section).

STARTING A CONVERSION

The combination of \overline{CS} (pin 25) and $\overline{R/C}$ (pin 24) low for a minimum of 40 ns immediately puts the sample/hold of the ADS8504 in the hold state and starts conversion n . \overline{BUSY} (pin 26) goes low and stays low until conversion n is completed and the internal output register has been updated. All new convert commands during \overline{BUSY} low will abort the conversion in progress and reset the ADC (see Figure 22).

The ADS8504 begins tracking the input signal at the end of the conversion. Allowing 4 μ s between convert commands assures accurate acquisition of a new signal. Refer to Table 1 for a summary of \overline{CS} , $\overline{R/C}$, and \overline{BUSY} states and Figure 19, Figure 20, and Figure 21 for the timing diagrams.

BASIC OPERATION (continued)

\overline{CS} and R/\overline{C} are internally ORed and level triggered. There is not a requirement which input goes low first when initiating a conversion. If, however, it is critical that \overline{CS} or R/\overline{C} initiates conversion n , be sure the less critical input is low at least 10 ns prior to the initiating input.

To reduce the number of control pins, \overline{CS} can be tied low using R/\overline{C} to control the read and convert modes. The parallel output becomes active whenever R/\overline{C} goes high. Refer to the READING DATA section.

Table 1. Control Line Functions for Read and Convert

| \overline{CS} | R/\overline{C} | \overline{BUSY} | OPERATION |
|-----------------|------------------|-------------------|---|
| 1 | X | X | None. Databus is in Hi-Z state. |
| ↓ | 0 | 1 | Initiates conversion n . Databus remains in Hi-Z state. |
| 0 | ↓ | 1 | Initiates conversion n . Databus enters Hi-Z state. |
| 0 | 1 | ↑ | Conversion n completed. Valid data from conversion n on the databus. |
| ↓ | 1 | 1 | Enables databus with valid data from conversion n . |
| ↓ | 1 | 0 | Enables databus with valid data from conversion $n-1$ ⁽¹⁾ . Conversion n in progress. |
| 0 | ↑ | 0 | Enables databus with valid data from conversion $n-1$ ⁽¹⁾ . Conversion n in progress. |
| 0 | 0 | ↑ | Data is invalid. \overline{CS} and/or R/\overline{C} must be high when \overline{BUSY} goes high. |
| X | ↓ | 0 | Conversion n is halted. Causes ADC to reset. ⁽²⁾ |

(1) See Figure 19 and Figure 20 for constraints on data valid from conversion $n-1$.

(2) See Figure 22 for details on ADC reset.

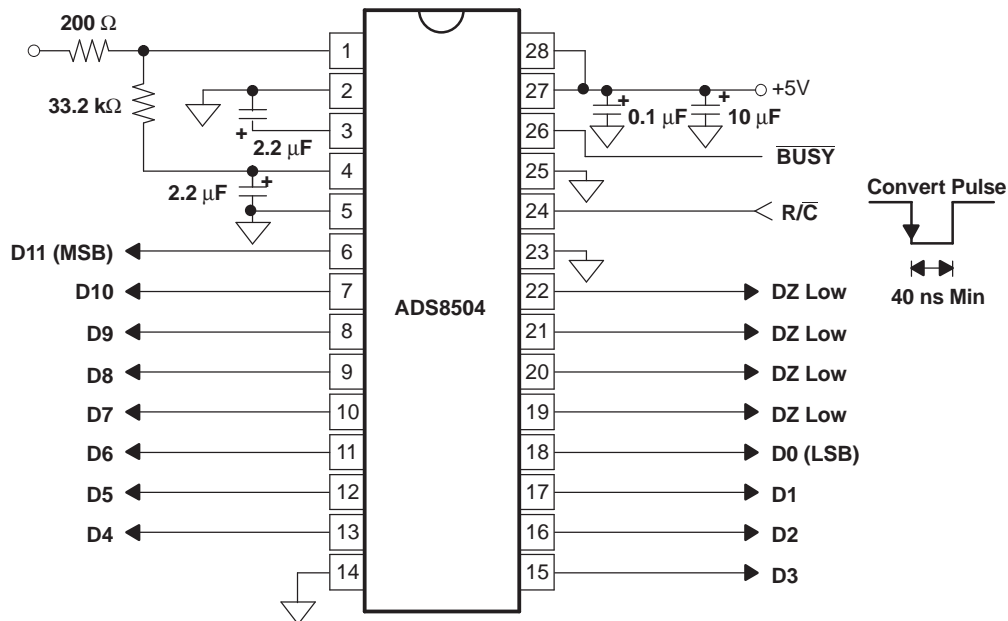

Figure 17. Basic Operation

READING DATA

The ADS8504 outputs full or byte-reading parallel data in binary 2's complement data output format. The parallel output is active when R/\overline{C} (pin 24) is high and \overline{CS} (pin 25) is low. Any other combination of \overline{CS} and R/\overline{C} 3-states the parallel output. Valid conversion data can be read in a full parallel, 12-bit word or two 8-bit bytes on pins 6-13 and pins 15-22. BYTE (pin 23) can be toggled to read both bytes within one conversion cycle. Refer to Table 2 for ideal output codes and Figure 18 for bit locations relative to the state of BYTE.

Table 2. Ideal Input Voltages and Output Codes

| DESCRIPTION | ANALOG INPUT | DIGITAL OUTPUT BINARY 2's COMPLEMENT | |
|-----------------------------|--------------|--------------------------------------|----------|
| | | BINARY CODE | HEX CODE |
| Full-scale range | ±10 V | | |
| Least significant bit (LSB) | 4.88 mV | | |
| Full scale (10 V-1 LSB) | 9.99512 V | 0111 1111 1111 | 7FF |
| Midscale | 0 V | 0000 0000 0000 | 000 |
| One LSB below midscale | -4.88 mV | 1111 1111 1111 | FFF |
| -Full scale | -10 V | 1000 0000 0000 | 800 |

PARALLEL OUTPUT (After a Conversion)

After conversion *n* is completed and the output registers have been updated, $\overline{\text{BUSY}}$ (pin 26) goes high. Valid data from conversion *n* is available on D11-D0 (pins 6-13 and 15-18). $\overline{\text{BUSY}}$ going high can be used to latch the data. Refer to [Table 3](#) and [Figure 19](#), [Figure 20](#), and [Figure 21](#) for timing specifications.

PARALLEL OUTPUT (During a Conversion)

After conversion *n* has been initiated, valid data from conversion *n-1* can be read and is valid up to t_2 (2.2 μs typ) after the start of conversion *n*. Do not attempt to read data from t_2 (2.2 μs typ) after the start of conversion *n* until $\overline{\text{BUSY}}$ (pin 26) goes high; this may result in reading invalid data. Refer to [Table 3](#) and [Figure 19](#), [Figure 20](#), and [Figure 21](#) for timing specifications.

Note: For the best possible performance, data should not be read during a conversion. The switching noise of the asynchronous data transfer can cause digital feedthrough degrading the converter's performance.

The number of control lines can be reduced by tying $\overline{\text{CS}}$ low while using the falling edge of $\text{R}/\overline{\text{C}}$ to initiate conversions and the rising edge of $\text{R}/\overline{\text{C}}$ to activate the output mode of the converter. See [Figure 19](#).

Table 3. Conversion Timing

| SYMBOL | DESCRIPTION | MIN | TYP | MAX | UNITS |
|----------------------|--|-----|-----|------|---------------|
| t_{w1} | Pulse duration, convert | 40 | | 1750 | ns |
| t_a | Access time, data valid after $\text{R}/\overline{\text{C}}$ low | | 2.2 | 3.2 | μs |
| t_{pd} | Propagation delay time, $\overline{\text{BUSY}}$ from $\text{R}/\overline{\text{C}}$ low | | 15 | 25 | ns |
| t_{w2} | Pulse duration, $\overline{\text{BUSY}}$ low | | | 2.2 | μs |
| t_{d1} | Delay time, $\overline{\text{BUSY}}$ after end of conversion | | 5 | | ns |
| t_{d2} | Delay time, aperture | | 5 | | ns |
| t_{conv} | Conversion time | | | 2.2 | μs |
| t_{acq} | Acquisition time | 1.8 | | | μs |
| t_{dis} | Disable time, bus | 10 | 30 | 83 | ns |
| t_{d3} | Delay time, $\overline{\text{BUSY}}$ after data valid | 35 | 50 | | ns |
| t_v | Valid time, previous data remains valid after $\text{R}/\overline{\text{C}}$ low | 1.5 | 2 | | μs |
| $t_{conv} + t_{acq}$ | Throughput time | | | 4 | μs |
| t_{su} | Setup time, $\text{R}/\overline{\text{C}}$ to $\overline{\text{CS}}$ | 10 | | | ns |
| t_c | Cycle time between conversions | 4 | | | μs |
| t_{en} | Enable time, bus | 10 | 30 | 83 | ns |
| t_{d4} | Delay time, BYTE | 5 | 10 | 30 | ns |

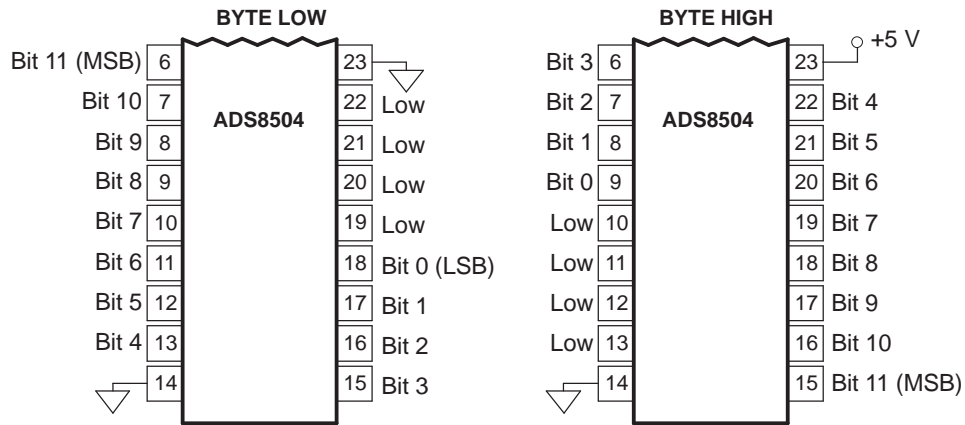

Figure 18. Bit Locations Relative to State of BYTE (Pin 23)

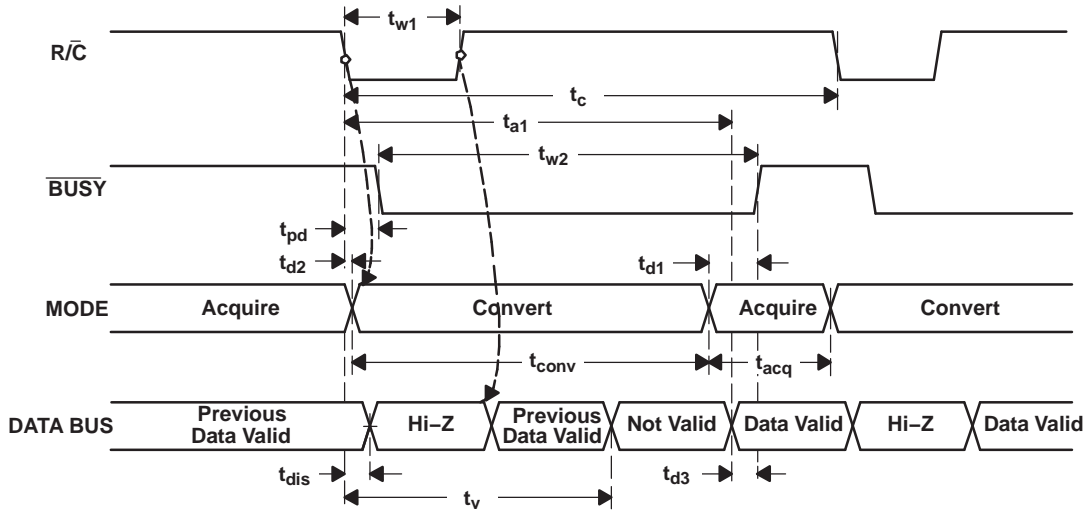

Figure 19. Conversion Timing with Outputs Enabled after Conversion (\overline{CS} Tied Low)

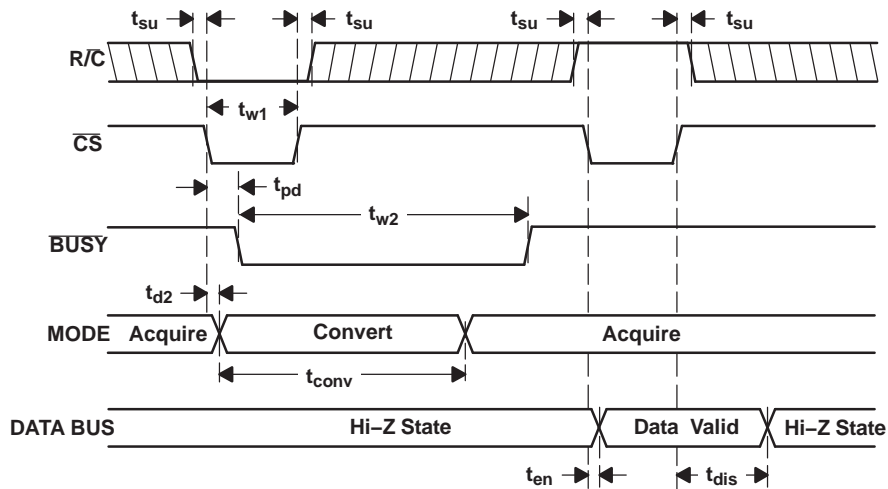

Figure 20. Using \overline{CS} to Control Conversion and Read Timing

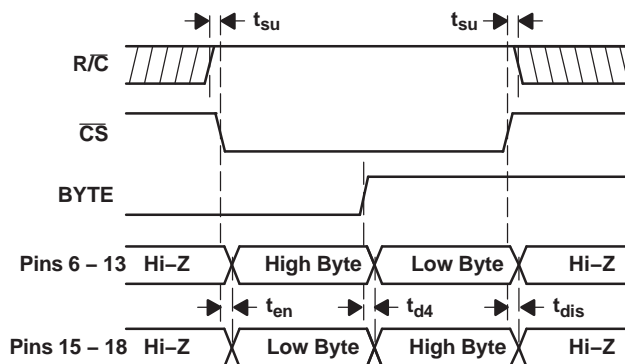

Figure 21. Using \overline{CS} and \overline{BYTE} to Control Data Bus

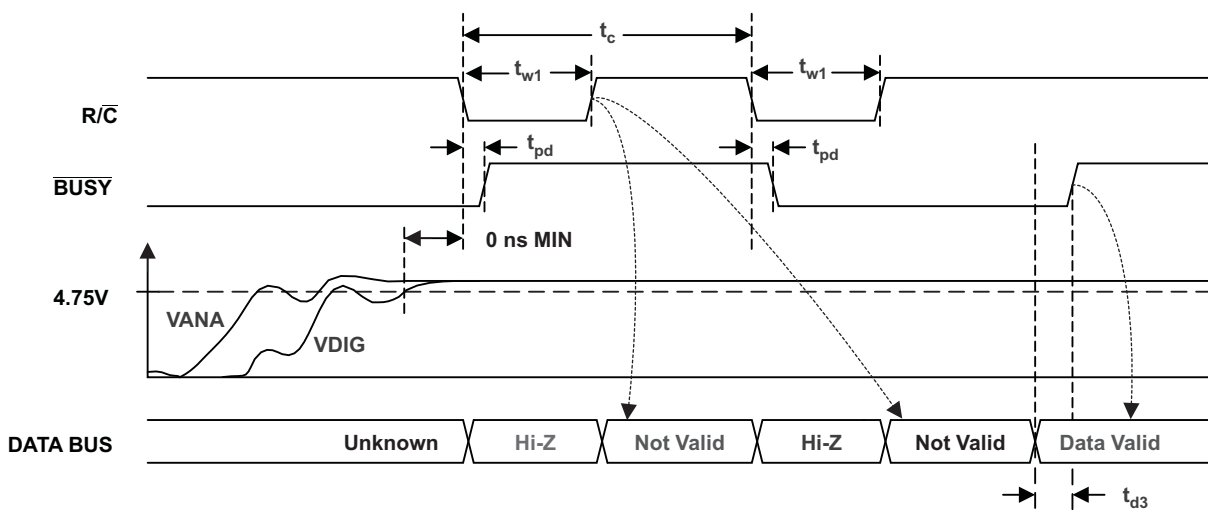

Figure 22. ADC Reset

ADC RESET

The ADC reset function of the ADS8504 can be used to terminate the current conversion cycle. Bringing R/\overline{C} low for at least 40 ns while $BUSY$ is low will initiate the ADC reset. To initiate a new conversion, R/\overline{C} must return to the high state and remain high long enough to acquire a new sample (see Table 3, t_c) before going low to initiate the next conversion sequence. In applications that do not monitor the $BUSY$ signal, it is recommended that the ADC reset function be implemented as part of a system initialization sequence.

INPUT RANGES

The ADS8504 offers a standard ± 10 -V input range. Figure 24 shows the necessary circuit connections for the ADS8504 with and without hardware trim. Offset and full-scale error specifications are tested and specified with the fixed resistors shown in Figure 24(b). Full-scale error includes offset and gain errors measured at both +FS and -FS. Adjustments for offset and gain are described in the Calibration section of this data sheet.

The offset and gain are adjusted internally to allow external trimming with a single supply. The external resistors compensate for this adjustment and can be left out if the offset and gain are corrected in software (refer to the Calibration section).

The nominal input impedance of 11.5 k Ω results from the combination of the internal resistor network shown on the front page of the product data sheet and the external resistors. The input resistor divider network provides inherent overvoltage protection assured to at least ± 25 V. The 1% resistors used for the external circuitry do not compromise the accuracy or drift of the converter. They have little influence relative to the internal resistors, and tighter tolerances are not required.

The input signal must be referenced to AGND1. This will minimize the ground loop problem typical to analog designs. The analog input should be driven by a low impedance source. A typical driving circuit using OPA627 or OPA132 is shown in Figure 23.

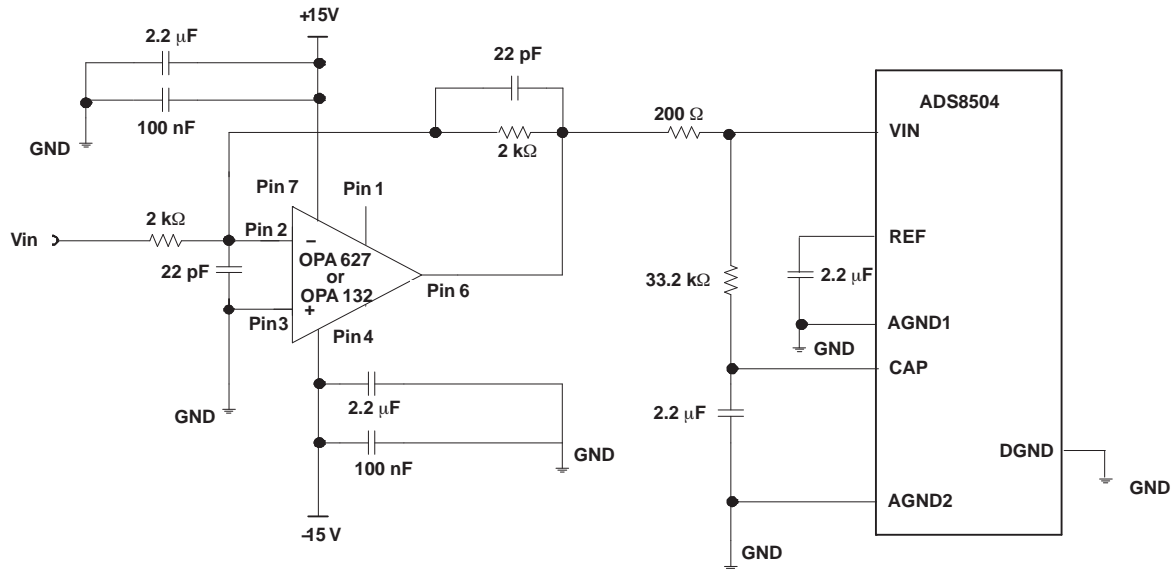

Figure 23. Typical Driving Circuitry (± 10 V, No Trim)

APPLICATION INFORMATION

CALIBRATION

The ADS8504 can be trimmed in hardware or software. The offset should be trimmed before the gain since the offset directly affects the gain. To achieve optimum performance, several iterations may be required.

Hardware Calibration

To calibrate the offset and gain of the ADS8504, install the proper resistors and potentiometers as shown in Figure 24(a).

Software Calibration

To calibrate the offset and gain of the ADS8504 in software, no external resistors are required. See the No Calibration section for details on the effects of the external resistors. Refer to Table 4 for range of offset and gain errors with and without external resistors.

No Calibration

See Figure 24(b) for circuit connections. The external resistors shown in Figure 24(b) may not be necessary in some applications. These resistors provide compensation for an internal adjustment of the offset and gain which allows calibration with a single supply. Refer to Table 4 for range of offset and gain errors with and without external resistors.

Table 4. Typical Offset (Bipolar Zero Error, BPZ) and Gain Errors With and Without External Resistors

| | | WITH EXTERNAL RESISTORS | WITHOUT EXTERNAL RESISTORS | UNITS |
|------------|-------------|-------------------------|----------------------------|----------|
| BPZ | | $-4.88 < BPZ < 4.88$ | $-56.6 < BPZ < -32.2$ | mV |
| | | $-1 < BPZ < 1$ | $-11.6 < BPZ < -6.6$ | LSBs |
| Gain error | +Full scale | $-0.25 < Error < 0.25$ | $-2.5 < Error < -1.25$ | % of FSR |
| | -Full scale | $-0.25 < Error < 0.25$ | $-3.5 < Error < -2.25$ | |

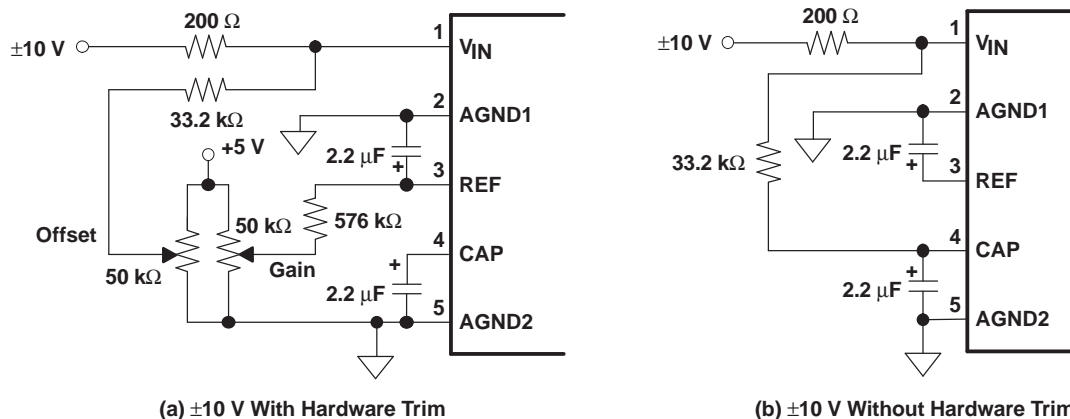

Note: Use 1% metal film resistors.

Figure 24. Circuit Diagram With and Without External Trim Hardware

REFERENCE

The ADS8504 can operate with its internal 2.5-V reference or an external reference. By applying an external reference to pin 5, the internal reference can be bypassed. The reference voltage at REF is buffered internally with the output on CAP (pin 4).

The internal reference has an 8 ppm/°C drift (typical) and accounts for approximately 20% of the full-scale error (FSE = ±0.5%).

REF

REF (pin 3) is an input for an external reference or the output for the internal 2.5-V reference. A 2.2- μ F capacitor should be connected as close to the REF pin as possible. The capacitor and the output resistance of REF create a low-pass filter to bandlimit noise on the reference. Using a smaller value capacitor introduces more noise to the reference degrading the SNR and SINAD. The REF pin should not be used to drive external ac or dc loads.

The range for the external reference is 2.3 V to 2.7 V and determines the actual LSB size. Increasing the reference voltage increases the full-scale range and the LSB size of the converter which can improve the SNR.

CAP

CAP (pin 4) is the output of the internal reference buffer. A 2.2- μ F capacitor should be placed as close to the CAP pin as possible to provide optimum switching currents for the CDAC throughout the conversion cycle and compensation for the output of the internal buffer. Using a capacitor any smaller than 1 μ F can cause the output buffer to oscillate and may not have sufficient charge for the CDAC. Capacitor values larger than 2.2 μ F have little affect on improving performance. The ESR (equivalent series resistance) of these compensation capacitors is also critical. Keep the total ESR under 3 Ω . See the TYPICAL CHARACTERISTICS section for how performance is affected by ESR.

The output of the buffer is capable of driving up to 2 mA of current to a dc load. A dc load requiring more than 2 mA of current from the CAP pin begins to degrade the linearity of the ADS8504. Using an external buffer allows the internal reference to be used for larger dc loads and ac loads. Do not attempt to directly drive an ac load with the output voltage on CAP. This causes performance degradation of the converter.

LAYOUT

POWER

For optimum performance, tie the analog and digital power pins to the same +5-V power supply and tie the analog and digital grounds together. As noted in the electrical specifications, the ADS8504 uses 90% of its power for the analog circuitry. The ADS8504 should be considered as an analog component.

The +5-V power for the A/D should be separate from the +5 V used for the system's digital logic. Connecting V_{DIG} (pin 28) directly to a digital supply can reduce converter performance due to switching noise from the digital logic. For best performance, the +5-V supply can be produced from whatever analog supply is used for the rest of the analog signal conditioning. If +12-V or +15-V supplies are present, a simple +5-V regulator can be used. Although it is not suggested, if the digital supply must be used to power the converter, be sure to properly filter the supply. Either using a filtered digital supply or a regulated analog supply, both V_{DIG} and V_{ANA} should be tied to the same +5-V source.

GROUNDING

Three ground pins are present on the ADS8504. DGND is the digital supply ground. AGND2 is the analog supply ground. AGND1 is the ground which all analog signals internal to the A/D are referenced. AGND1 is more susceptible to current induced voltage drops and must have the path of least resistance back to the power supply.

All the ground pins of the A/D should be tied to the analog ground plane, separated from the system's digital logic ground, to achieve optimum performance. Both analog and digital ground planes should be tied to the *system* ground as near to the power supplies as possible. This helps to prevent dynamic digital ground currents from modulating the analog ground through a common impedance to power ground.

SIGNAL CONDITIONING

The FET switches used for the sample hold on many CMOS A/D converters release a significant amount of charge injection which can cause the driving op amp to oscillate. The FET switch on the ADS8504, compared to the FET switches on other CMOS A/D converters, releases 5%-10% of the charge. There is also a resistive front end which attenuates any charge which is released. The end result is a minimal requirement for the anti-alias filter on the front end. Any op amp sufficient for the signal in an application is sufficient to drive the ADS8504.

The resistive front end of the ADS8504 also provides an assured ± 25 -V overvoltage protection. In most cases, this eliminates the need for external input protection circuitry.

LAYOUT (continued)**INTERMEDIATE LATCHES**

The ADS8504 does have 3-state outputs for the parallel port, but intermediate latches should be used if the bus is to be active during conversions. If the bus is not active during conversion, the 3-state outputs can be used to isolate the A/D from other peripherals on the same bus. The 3-state outputs can also be used when the A/D is the only peripheral on the data bus.

Intermediate latches are beneficial on any monolithic A/D converter. The ADS8504 has an internal LSB size of 610 μV . Transients from fast switching signals on the parallel port, even when the A/D is 3-stated, can be coupled through the substrate to the analog circuitry causing degradation of converter performance.

Revision History

NOTE: Page numbers for previous revisions may differ from page numbers in the current version.

| Changes from Original (June, 2005) to A Revision | Page |
|---|-------------|
| • Deleted text from basic operation description | 8 |
| • Changed text in starting a conversion description..... | 8 |
| • Changed operation descriptions and R/\bar{C} in table | 9 |
| • Added SAR Reset Timing | 12 |
| • Added ADC RESET section | 12 |

PACKAGING INFORMATION

| Orderable Device | Status ⁽¹⁾ | Package Type | Package Drawing | Pins | Package Qty | Eco Plan ⁽²⁾ | Lead/Ball Finish | MSL Peak Temp ⁽³⁾ |
|------------------|-----------------------|--------------|-----------------|------|-------------|-------------------------|------------------|------------------------------|
| ADS8504IBDW | ACTIVE | SOIC | DW | 28 | 20 | Green (RoHS & no Sb/Br) | CU NIPDAU | Level-2-260C-1 YEAR |
| ADS8504IBDWG4 | ACTIVE | SOIC | DW | 28 | 20 | Green (RoHS & no Sb/Br) | CU NIPDAU | Level-2-260C-1 YEAR |
| ADS8504IBDWR | ACTIVE | SOIC | DW | 28 | 1000 | Green (RoHS & no Sb/Br) | CU NIPDAU | Level-2-260C-1 YEAR |
| ADS8504IBDWRG4 | ACTIVE | SOIC | DW | 28 | 1000 | Green (RoHS & no Sb/Br) | CU NIPDAU | Level-2-260C-1 YEAR |

⁽¹⁾ The marketing status values are defined as follows:

ACTIVE: Product device recommended for new designs.

LIFEBUY: TI has announced that the device will be discontinued, and a lifetime-buy period is in effect.

NRND: Not recommended for new designs. Device is in production to support existing customers, but TI does not recommend using this part in a new design.

PREVIEW: Device has been announced but is not in production. Samples may or may not be available.

OBSOLETE: TI has discontinued the production of the device.

⁽²⁾ Eco Plan - The planned eco-friendly classification: Pb-Free (RoHS), Pb-Free (RoHS Exempt), or Green (RoHS & no Sb/Br) - please check <http://www.ti.com/productcontent> for the latest availability information and additional product content details.

TBD: The Pb-Free/Green conversion plan has not been defined.

Pb-Free (RoHS): TI's terms "Lead-Free" or "Pb-Free" mean semiconductor products that are compatible with the current RoHS requirements for all 6 substances, including the requirement that lead not exceed 0.1% by weight in homogeneous materials. Where designed to be soldered at high temperatures, TI Pb-Free products are suitable for use in specified lead-free processes.

Pb-Free (RoHS Exempt): This component has a RoHS exemption for either 1) lead-based flip-chip solder bumps used between the die and package, or 2) lead-based die adhesive used between the die and leadframe. The component is otherwise considered Pb-Free (RoHS compatible) as defined above.

Green (RoHS & no Sb/Br): TI defines "Green" to mean Pb-Free (RoHS compatible), and free of Bromine (Br) and Antimony (Sb) based flame retardants (Br or Sb do not exceed 0.1% by weight in homogeneous material)

⁽³⁾ MSL, Peak Temp. -- The Moisture Sensitivity Level rating according to the JEDEC industry standard classifications, and peak solder temperature.

Important Information and Disclaimer:The information provided on this page represents TI's knowledge and belief as of the date that it is provided. TI bases its knowledge and belief on information provided by third parties, and makes no representation or warranty as to the accuracy of such information. Efforts are underway to better integrate information from third parties. TI has taken and continues to take reasonable steps to provide representative and accurate information but may not have conducted destructive testing or chemical analysis on incoming materials and chemicals. TI and TI suppliers consider certain information to be proprietary, and thus CAS numbers and other limited information may not be available for release.

In no event shall TI's liability arising out of such information exceed the total purchase price of the TI part(s) at issue in this document sold by TI to Customer on an annual basis.

TAPE AND REEL BOX INFORMATION

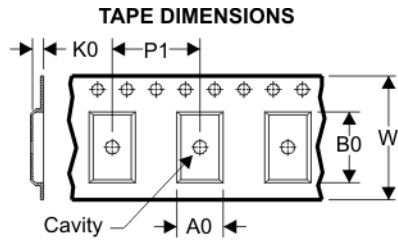
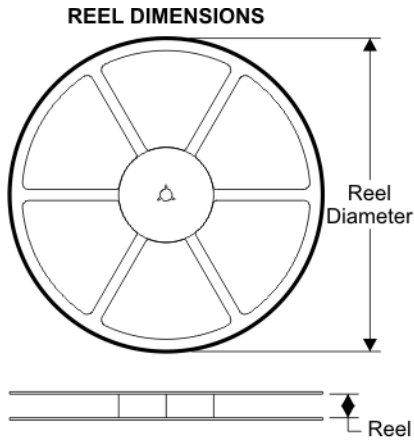

| | |
|----|---|
| A0 | Dimension designed to accommodate the component width |
| B0 | Dimension designed to accommodate the component length |
| K0 | Dimension designed to accommodate the component thickness |
| W | Overall width of the carrier tape |
| P1 | Pitch between successive cavity centers |

QUADRANT ASSIGNMENTS FOR PIN 1 ORIENTATION IN TAPE

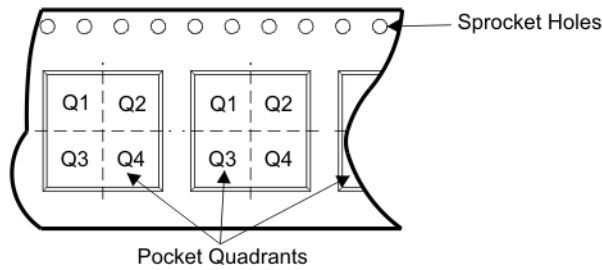

| Device | Package | Pins | Site | Reel Diameter (mm) | Reel Width (mm) | A0 (mm) | B0 (mm) | K0 (mm) | P1 (mm) | W (mm) | Pin1 Quadrant |
|--------------|---------|------|---------|--------------------|-----------------|---------|---------|---------|---------|--------|---------------|
| ADS8504IBDWR | DW | 28 | SITE 60 | 330 | 32 | 11.35 | 18.67 | 3.1 | 16 | 32 | Q1 |

TAPE AND REEL BOX DIMENSIONS



| Device | Package | Pins | Site | Length (mm) | Width (mm) | Height (mm) |
|--------------|---------|------|---------|-------------|------------|-------------|
| ADS8504IBDWR | DW | 28 | SITE 60 | 346.0 | 346.0 | 49.0 |

DW (R-PDSO-G28)

PLASTIC SMALL-OUTLINE PACKAGE

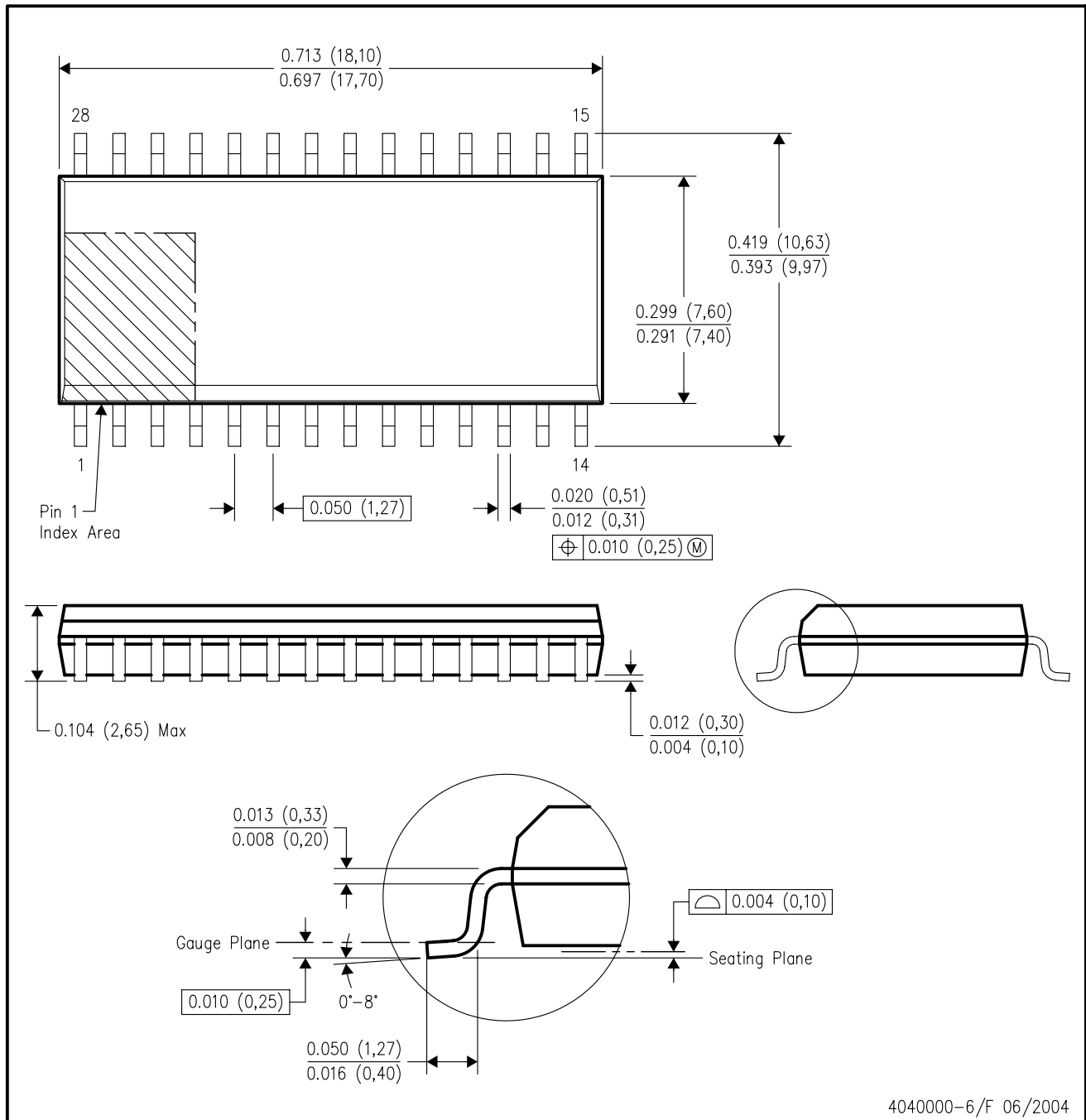

4040000-6/F 06/2004

- NOTES:
- A. All linear dimensions are in inches (millimeters).
 - B. This drawing is subject to change without notice.
 - C. Body dimensions do not include mold flash or protrusion not to exceed 0.006 (0,15).
 - D. Falls within JEDEC MS-013 variation AE.

IMPORTANT NOTICE

Texas Instruments Incorporated and its subsidiaries (TI) reserve the right to make corrections, modifications, enhancements, improvements, and other changes to its products and services at any time and to discontinue any product or service without notice. Customers should obtain the latest relevant information before placing orders and should verify that such information is current and complete. All products are sold subject to TI's terms and conditions of sale supplied at the time of order acknowledgment.

TI warrants performance of its hardware products to the specifications applicable at the time of sale in accordance with TI's standard warranty. Testing and other quality control techniques are used to the extent TI deems necessary to support this warranty. Except where mandated by government requirements, testing of all parameters of each product is not necessarily performed.

TI assumes no liability for applications assistance or customer product design. Customers are responsible for their products and applications using TI components. To minimize the risks associated with customer products and applications, customers should provide adequate design and operating safeguards.

TI does not warrant or represent that any license, either express or implied, is granted under any TI patent right, copyright, mask work right, or other TI intellectual property right relating to any combination, machine, or process in which TI products or services are used. Information published by TI regarding third-party products or services does not constitute a license from TI to use such products or services or a warranty or endorsement thereof. Use of such information may require a license from a third party under the patents or other intellectual property of the third party, or a license from TI under the patents or other intellectual property of TI.

Reproduction of TI information in TI data books or data sheets is permissible only if reproduction is without alteration and is accompanied by all associated warranties, conditions, limitations, and notices. Reproduction of this information with alteration is an unfair and deceptive business practice. TI is not responsible or liable for such altered documentation. Information of third parties may be subject to additional restrictions.

Resale of TI products or services with statements different from or beyond the parameters stated by TI for that product or service voids all express and any implied warranties for the associated TI product or service and is an unfair and deceptive business practice. TI is not responsible or liable for any such statements.

TI products are not authorized for use in safety-critical applications (such as life support) where a failure of the TI product would reasonably be expected to cause severe personal injury or death, unless officers of the parties have executed an agreement specifically governing such use. Buyers represent that they have all necessary expertise in the safety and regulatory ramifications of their applications, and acknowledge and agree that they are solely responsible for all legal, regulatory and safety-related requirements concerning their products and any use of TI products in such safety-critical applications, notwithstanding any applications-related information or support that may be provided by TI. Further, Buyers must fully indemnify TI and its representatives against any damages arising out of the use of TI products in such safety-critical applications.

TI products are neither designed nor intended for use in military/aerospace applications or environments unless the TI products are specifically designated by TI as military-grade or "enhanced plastic." Only products designated by TI as military-grade meet military specifications. Buyers acknowledge and agree that any such use of TI products which TI has not designated as military-grade is solely at the Buyer's risk, and that they are solely responsible for compliance with all legal and regulatory requirements in connection with such use.

TI products are neither designed nor intended for use in automotive applications or environments unless the specific TI products are designated by TI as compliant with ISO/TS 16949 requirements. Buyers acknowledge and agree that, if they use any non-designated products in automotive applications, TI will not be responsible for any failure to meet such requirements.

Following are URLs where you can obtain information on other Texas Instruments products and application solutions:

| Products | | Applications | |
|-----------------------|--|---------------------|--|
| Amplifiers | amplifier.ti.com | Audio | www.ti.com/audio |
| Data Converters | dataconverter.ti.com | Automotive | www.ti.com/automotive |
| DSP | dsp.ti.com | Broadband | www.ti.com/broadband |
| Interface | interface.ti.com | Digital Control | www.ti.com/digitalcontrol |
| Logic | logic.ti.com | Military | www.ti.com/military |
| Power Mgmt | power.ti.com | Optical Networking | www.ti.com/opticalnetwork |
| Microcontrollers | microcontroller.ti.com | Security | www.ti.com/security |
| RFID | www.ti-rfid.com | Telephony | www.ti.com/telephony |
| Low Power Wireless | www.ti.com/lpw | Video & Imaging | www.ti.com/video |
| | | Wireless | www.ti.com/wireless |

Mailing Address: Texas Instruments, Post Office Box 655303, Dallas, Texas 75265
Copyright © 2007, Texas Instruments Incorporated