

***MSP-FET430 FLASH Emulation Tool (FET)***  
***(For use with IAR Workbench Version 3.x)***

***User's Guide***

## IMPORTANT NOTICE

Texas Instruments Incorporated and its subsidiaries (TI) reserve the right to make corrections, modifications, enhancements, improvements, and other changes to its products and services at any time and to discontinue any product or service without notice. Customers should obtain the latest relevant information before placing orders and should verify that such information is current and complete. All products are sold subject to TI's terms and conditions of sale supplied at the time of order acknowledgment.

TI warrants performance of its hardware products to the specifications applicable at the time of sale in accordance with TI's standard warranty. Testing and other quality control techniques are used to the extent TI deems necessary to support this warranty. Except where mandated by government requirements, testing of all parameters of each product is not necessarily performed.

TI assumes no liability for applications assistance or customer product design. Customers are responsible for their products and applications using TI components. To minimize the risks associated with customer products and applications, customers should provide adequate design and operating safeguards.

TI does not warrant or represent that any license, either express or implied, is granted under any TI patent right, copyright, mask work right, or other TI intellectual property right relating to any combination, machine, or process in which TI products or services are used. Information published by TI regarding third-party products or services does not constitute a license from TI to use such products or services or a warranty or endorsement thereof. Use of such information may require a license from a third party under the patents or other intellectual property of the third party, or a license from TI under the patents or other intellectual property of TI.

Reproduction of information in TI data books or data sheets is permissible only if reproduction is without alteration and is accompanied by all associated warranties, conditions, limitations, and notices. Reproduction of this information with alteration is an unfair and deceptive business practice. TI is not responsible or liable for such altered documentation.

Resale of TI products or services with statements different from or beyond the parameters stated by TI for that product or service voids all express and any implied warranties for the associated TI product or service and is an unfair and deceptive business practice. TI is not responsible or liable for any such statements.

Following are URLs where you can obtain information on other Texas Instruments products and application solutions:

<b>Products</b>		<b>Applications</b>	
Amplifiers	<a href="http://amplifier.ti.com">amplifier.ti.com</a>	Audio	<a href="http://www.ti.com/audio">www.ti.com/audio</a>
Data Converters	<a href="http://dataconverter.ti.com">dataconverter.ti.com</a>	Automotive	<a href="http://www.ti.com/automotive">www.ti.com/automotive</a>
DSP	<a href="http://dsp.ti.com">dsp.ti.com</a>	Broadband	<a href="http://www.ti.com/broadband">www.ti.com/broadband</a>
Interface	<a href="http://interface.ti.com">interface.ti.com</a>	Digital Control	<a href="http://www.ti.com/digitalcontrol">www.ti.com/digitalcontrol</a>
Logic	<a href="http://logic.ti.com">logic.ti.com</a>	Military	<a href="http://www.ti.com/military">www.ti.com/military</a>
Power Mgmt	<a href="http://power.ti.com">power.ti.com</a>	Optical Networking	<a href="http://www.ti.com/opticalnetwork">www.ti.com/opticalnetwork</a>
Microcontrollers	<a href="http://microcontroller.ti.com">microcontroller.ti.com</a>	Security	<a href="http://www.ti.com/security">www.ti.com/security</a>
		Telephony	<a href="http://www.ti.com/telephony">www.ti.com/telephony</a>
		Video & Imaging	<a href="http://www.ti.com/video">www.ti.com/video</a>
		Wireless	<a href="http://www.ti.com/wireless">www.ti.com/wireless</a>

Mailing Address: Texas Instruments  
Post Office Box 655303 Dallas, Texas 75265

# Read This First

---

---

---

### ***About This Manual***

This manual documents the Texas Instruments MSP-FET430 Flash Emulation Tool (FET). The FET is the program development tool for the MSP430 ultra low power microcontroller. Both available interfaces, the Parallel-Port-Interface and the USB-Interface, are described here.

### ***How to Use This Manual***

Read and follow the Get Started Now! chapter. This chapter will enable you to inventory your FET and then it will instruct you to install the software and hardware, and then run the demonstration programs. Once you've been demonstrated how quick and easy it is to use the FET, we suggest that you complete the reading of this manual.

This manual describes the set-up and operation of the FET, but does not fully teach the MSP430 or the development software systems. For details of these items, refer to the appropriate Texas Instruments and IAR documents listed in Chapter 1.10 Important MSP430 Documents on the CD-ROM and WEB.

This manual is applicable to the following tools (and devices):

MSP-FET430X110 (for the MSP430F11xIDW, MSP430F11x1AIDW, and MSP430F11x2IDW devices)

MSP-FET430P120 (for the MSP430F12xIDW and MSP430F12x2IDW devices)

MSP-FET430P140 (for the MSP430F13xIPM, MSP430F14xIPM, MSP430F15xIPM, MSP430F16xIPM, and MSP430F161xIPM devices)

MSP-FET430P410 (for the MSP430F41xIPM devices)

MSP-FET430P430 (for the MSP430F43xIPN devices)

MSP-FET430P440 (for the MSP430F43xIPZ and MSP430F44xIPZ devices)

MSP-FET430UIF (debug interface with USB connection, for all MSP430 Flash based devices)

Below tools contain the USB-Debug-Interface and the respective target-socket module:

MSP-FET430U28 (for MSP430 devices in 20 and 28 pin DW-Packages)

MSP-FET430U48 (for MSP430 devices in 48 pin DL-Package)

MSP-FET430U64 (for MSP430 devices in 64 pin PM-Package)

MSP-FET430U80 (for MSP430 devices in 80 pin PN-Package)

MSP-FET430U100 (for MSP430 devices in 100 pin PZ-Package)

This tool contains the most up-to-date materials available at the time of packaging. For the latest materials (data sheets, user's guides, software, applications, etc.), visit the Texas Instruments MSP430 web site at [www.ti.com/msp430](http://www.ti.com/msp430), or contact your local Texas Instruments sales office.

### ***Information About Cautions and Warnings***

This book may contain cautions and warnings.

**This is an example of a caution statement.**

**A caution statement describes a situation that could potentially damage your software or equipment.**

**CAUTION**

**This is an example of a warning statement.**

**A warning statement describes a situation that could potentially cause harm to you.**

**WARNING**

The information in a caution or a warning is provided for your protection. Read each caution and warning carefully.

### ***Related Documentation From Texas Instruments***

MSP430xxxx Device Data Sheets

- ❑ MSP430x1xx Family User's Guide, SLAU049
- ❑ MSP430x3xx Family User's Guide, SLAU012
- ❑ MSP430x4xx Family User's Guide, SLAU056

### ***If You Need Assistance***

Support for the MSP430 device and the FET is provided by the Texas Instruments Product Information Center (PIC). Contact information for the PIC can be found on the Texas Instruments web site at [www.ti.com](http://www.ti.com). Additional device-specific information can be found on the MSP430 web site at [www.ti.com/msp430](http://www.ti.com/msp430).

**Note: Kickstart is supported by Texas Instruments**

Although Kickstart is a product of IAR, Texas Instruments provides the support for it. Therefore, please do not request support for Kickstart from IAR. Please consult the extensive documentation provided with Kickstart before requesting assistance.

### ***FCC Warning***

This equipment is intended for use in a laboratory test environment only. It generates, uses, and can radiate radio frequency energy and has not been tested for compliance with the limits of computing devices pursuant to subpart J of part 15 of FCC rules, which are designed to provide reasonable protection against radio frequency interference. Operation of this equipment in other environments may cause interference with radio communications, in which case the user at his own expense will be required to take whatever measures may be required to correct this interference.



# Contents

---

---

---

<b>Read This First</b> .....	<b>iii</b>
About This Manual .....	iii
How to Use This Manual .....	iii
Information About Cautions and Warnings .....	iv
Related Documentation From Texas Instruments.....	iv
If You Need Assistance.....	v
FCC Warning .....	v
<b>Contents</b> .....	<b>vii</b>
<b>Figures</b> .....	<b>ix</b>
<b>Tables</b> .....	<b>ix</b>
<b>Get Started Now!</b> .....	<b>1-1</b>
1.1 Kit Contents, MSP-FET430X110.....	1-2
1.2 Kit Contents, MSP-FET430Pxx0 ('P120, 'P140, 'P410, 'P430, 'P440).....	1-2
1.3 Kit Contents, MSP-FET430UIF .....	1-3
1.4 Kit Contents, MSP-FET430Uxx ('U28, 'U48, 'U64, 'U80, 'U100) .....	1-3
1.5 Software Installation.....	1-4
1.6 Hardware Installation, MSP-FET430X110 .....	1-4
1.7 Hardware Installation, MSP-FET430Pxx0 ('P120, 'P140, 'P410, 'P430, 'P440).....	1-4
1.8 Hardware Installation, MSP-FET430UIF .....	1-5
1.9 "Flash"ing the LED .....	1-5
1.10 Important MSP430 Documents on the CD-ROM and WEB .....	1-7
<b>Development Flow</b> .....	<b>2-1</b>
2.1 Overview .....	2-2
2.2 Using Kickstart .....	2-2
2.2.1 Project Settings.....	2-3
2.2.2 Creating a Project from Scratch.....	2-5
2.2.3 Using an Existing IAR V1.x/V2.x Project .....	2-6
2.2.4 Stack Management within the .xcl Files .....	2-6
2.2.5 How to Generate Texas Instruments .TXT (and other format) Files .....	2-7
2.2.6 Overview of Example Programs .....	2-7
2.3 Using C-SPY .....	2-8
2.3.1 Breakpoint Types.....	2-8
2.3.2 Using Breakpoints.....	2-8
2.3.3 Using Single Step .....	2-9
2.3.4 Using Watch Windows.....	2-10
<b>Design Considerations for In-Circuit Programming</b> .....	<b>3-1</b>
3.1 Bootstrap Loader.....	3-2
3.2 External Power.....	3-2
3.3 Device Signals.....	3-3
3.4 Signal Connections for In-System Programming and Debugging, MSP-FET430X110 .....	3-4
3.5 Signal Connections for In-System Programming and Debugging, MSP-FET430IF, MSP-FET430UIF .....	3-6

<b>Frequently Asked Questions.....</b>	<b>1-1</b>
A.1 Hardware .....	A-2
A.2 Program Development (Assembler, C-Compiler, Linker) .....	A-3
A.3 Debugging (C-SPY).....	A-5
<b>Hardware.....</b>	<b>B-1</b>
<b>FET Specific Menus .....</b>	<b>C-1</b>
C.1 EMULATOR.....	C-2
C.1.1 EMULATOR->RELEASE JTAG ON GO.....	C-2
C.1.2 EMULATOR->RESYNCHRONIZE JTAG .....	C-2
C.1.3 EMULATOR->INIT NEW DEVICE.....	C-2
C.1.4 EMULATOR->SHOW USED BREAKPOINTS.....	C-2
C.1.5 EMULATOR->ADVANCED->GENERAL CLOCK CONTROL.....	C-2
C.1.6 EMULATOR->ADVANCED->EMULATION MODE .....	C-2
C.1.7 EMULATOR->ADVANCED->MEMORY DUMP .....	C-3
C.1.8 EMULATOR->ADVANCED->BREAKPOINT COMBINER .....	C-3
C.1.9 EMULATOR->STATE STORAGE .....	C-3
C.1.10 EMULATOR->STATE STORAGE WINDOW .....	C-3
C.1.11 EMULATOR->SEQUENCER.....	C-3
C.1.12 EMULATOR->"POWER ON" RESET .....	C-3
C.1.13 EMULATOR->SECURE.....	C-3
C.1.14 EMULATOR->GIE on/off .....	C-3
C.1.15 EMULATOR->LEAVE TARGET RUNNING .....	C-4
C.1.16 EMULATOR->FORCE SINGLE STEPPING .....	C-4
C.1.17 EMULATOR->SET VCC .....	C-4
<b>80-pin MSP430F44x and MSP430F43x Device Emulation .....</b>	<b>D-1</b>
<b>TI to IAR 2.x/3.x Assembler Migration .....</b>	<b>E-1</b>
E.1 Segment Control.....	E-2
E.2 Translating Asm430 Assembler Directives to A430 Directives.....	E-2
E.2.1 Introduction .....	E-2
E.2.2 Character strings.....	E-2
E.2.3 Section Control Directives.....	E-3
E.2.4 Constant Initialization Directives.....	E-4
E.2.5 Listing Control Directives .....	E-4
E.2.6 File Reference Directives.....	E-5
E.2.7 Conditional-Assembly Directives .....	E-5
E.2.8 Symbol Control Directives.....	E-6
E.2.9 Macro Directives .....	E-7
E.2.10 Miscellaneous Directives .....	E-7
E.2.11 Preprocessor Directives.....	E-8
E.2.12 Alphabetical Listing and Cross Reference of Asm430 Directives.....	E-8
E.2.13 Additional A430 Directives (IAR) .....	E-8
<b>MSP-FET430UIF Installation Guide.....</b>	<b>F-1</b>
F.1 Hardware Installation.....	F-2

# Figures

---

---

Figure 3-1. Signal Connections for MSP-FET430X110 .....	3-5
Figure 3-2. JTAG Signal Connections.....	3-7
Figure B-1. MSP-FET430X110, Schematic .....	B-2
Figure B-2. MSP-FET430X110, PCB Pictorials .....	B-3
Figure B-3. MSP-FET430IF FET Interface Module, Schematic .....	B-4
Figure B-4. MSP-FET430IF FET Interface Module, PCB Pictorial .....	B-5
Figure B-5. MSP-TS430DW28 Target Socket Module, Schematic .....	B-6
Figure B-6. MSP-TS430DW28 Target Socket Module, PCB Pictorials.....	B-7
Figure B-7. MSP-TS430DL48 Target Socket Module Schematic.....	B-8
Figure B-8. MSP-TS430DL48 Target Socket Module, PCB .....	B-9
Figure B-9. MSP-TS430PM64 Target Socket Module, Schematic, Rev. 1.1 .....	B-10
Figure B-10. MSP-TS430PM64 Target Socket <odule, PCB Pictorials, Rev. 1.1 ....	B-11
Figure B-11. MSP-TSPN80 Target Socket Module, Schematic .....	B-12
Figure B-12. MSP-TSPN80 Target Socket Module, PCB Pictorials.....	B-13
Figure B-13. MSP-TSPZ100 Target Socket Module, Schematic.....	B-14
Figure B-14. MSP-TSPZ100 Target Socket Module, PCB Pictorials .....	B-15
Figure B-15. MSP-FET430UIF USB Interface Schematics .....	B-16
Figure F-1. WinXP Hardware Recognition .....	F-2
Figure F-2. WinXP Hardware Wizard .....	F-2
Figure F-3. WinXP Driver Location Selection Folder.....	F-3
Figure F-4. WinXP Driver Installation.....	F-4
Figure F-5. Device Manager .....	F-5

# Tables

---

---

Table 2-1. Number of Device Breakpoints and Other Emulation Features.....	2-8
Table D-1. F4xx/80-Pin Signal Mapping .....	D-2

# Get Started Now!

---

---

---

This chapter will enable you to inventory your FET and then it will instruct you to install the software and hardware, and then run the demonstration programs.

<b>Topic</b>	<b>Page</b>
<b>1.1 Kit Contents, MSP-FET430X110</b>	<b>1-2</b>
<b>1.2 Kit Contents, MSP-FET430Pxx0 ('P120, 'P140, 'P410, 'P430, 'P440)</b>	<b>1-2</b>
<b>1.3 Kit Contents, MSP-FET430UIF</b>	<b>1-3</b>
<b>1.4 Kit Contents, MSP-FET430Uxx ('U28, 'U48, 'U64, 'U80, 'U100)</b>	<b>1-3</b>
<b>1.5 Software Installation</b>	<b>1-4</b>
<b>1.6 Hardware Installation, MSP-FET430X110</b>	<b>1-4</b>
<b>1.7 Hardware Installation, MSP-FET430Pxx0 ('P120, 'P140, 'P410, 'P430, 'P440)</b>	<b>1-4</b>
<b>1.8 Hardware Installation, MSP-FET430UIF</b>	<b>1-5</b>
<b>1.9 "Flash"ing the LED</b>	<b>1-5</b>
<b>1.10 Important MSP430 Documents on the CD-ROM and WEB</b>	<b>1-7</b>

## 1.1 Kit Contents, MSP-FET430X110

One READ ME FIRST document.

One MSP430 CD-ROM.

One MSP-FET430X110 Flash Emulation Tool. This is the PCB on which is mounted a 20-pin ZIF socket for the MSP430F11xIDW, MSP430F11x1AIDW, or MSP430F11x2IDW device. A 25-conductor cable originates from the FET.

One small box containing two MSP430F1121AIDW device samples.

## 1.2 Kit Contents, MSP-FET430Pxx0 ('P120, 'P140, 'P410, 'P430, 'P440)

One READ ME FIRST document.

One MSP430 CD-ROM.

One MSP-FETP430IF FET Interface module. This is the unit that has a 25-pin male D-Sub connector on one end of the case and a 2x7 pin male connector on the other end of the case.

**MSP-FET430P120:** One MSP-TS430DW28 Target Socket module. This is the PCB on which is mounted a 28-pin ZIF socket for the MSP430F12xIDW or MSP430F12x2IDW device. A 2x7 pin male connector is also present on the PCB.

**MSP-FET430P140:** One MSP-TS430PM64 Target Socket module. This is the PCB on which is mounted a 64-pin clam-shell-style socket for the MSP430F13xIPM, MSP430F14xIPM, MSP430F15xIPM, MSP430F16xIPM, or MSP430F161xIPM device. A 2x7 pin male connector is also present on the PCB.

**MSP-FET430P410:** One MSP-TS430PM64 Target Socket module. This is the PCB on which is mounted a 64-pin clam-shell-style socket for the MSP430F41xIPM device. A 2x7 pin male connector is also present on the PCB.

**MSP-FET430P430:** One MSP-TS430PN80 Target Socket module. This is the PCB on which is mounted an 80-pin ZIF socket for the MSP430F43xIPN device. A 2x7 pin male connector is also present on the PCB.

**MSP-FET430P440:** One MSP-TS430PZ100 Target Socket module. This is the PCB on which is mounted a 100-pin ZIF socket for the MSP430F43xIPZ or MSP430F44xIPZ device. A 2x7 pin male connector is also present on the PCB.

One 25-conductor cable.

One 14-conductor cable.

**MSP-FET430P120:** Four PCB 1x14 pin headers (Two male and two female).

**MSP-FET430P140:** Eight PCB 1x16 pin headers (Four male and four female).

**MSP-FET430P410:** Eight PCB 1x16 pin headers (Four male and four female).

**MSP-FET430P430:** Eight PCB 1x20 pin headers (Four male and four female).

**MSP-FET430P440:** Eight PCB 1x25 pin headers (Four male and four female).

One small box containing two or four MSP430 device samples.

**MSP-FET430P120:** MSP430F123IDW and/or MSP430F1232IDW

**MSP-FET430P140:** MSP430F149IPM and/or MSP430F169IPM

**MSP-FET430P410:** MSP430F413IPM

**MSP-FET430P430:** MSP430F437IPN and/or MSP430FG439

**MSP-FET430P440:** MSP430F449IPZ

Consult the device data sheets for device specifications. A list of device errata can be found at <http://www.ti.com/sc/cgi-bin/buglist.cgi>

### 1.3 Kit Contents, MSP-FET430UIF

- One READ ME FIRST document
- One MSP430 CD-ROM
- One MSP-FET430UIF interface module
- One USB-Cable
- One 14-conductor cable

### 1.4 Kit Contents, MSP-FET430Uxx ('U28, 'U48, 'U64, 'U80, 'U100)

One READ ME FIRST document

One MSP430 CD-ROM

One MSP-FET430UIF USB-Interface module. This is the unit that has a USB B-connector on one end of the case, and a 2x7 pin male connector on the other end of the case.

**MSP-FET430U28:** One MSP-TS430DW28 Target Socket module. This is the PCB on which is mounted a 28-pin ZIF socket. It fits all MSP430 devices in 20 and 28 pin DW-Packages. A 2x7 pin male connector is also present on the PCB.

**MSP-FET430U48:** One MSP-TS430DL48 Target Socket module. This is the PCB on which is mounted a 48-pin ZIF socket. It fits all MSP430 devices in 48 pin DL-Package. A 2x7 pin male connector is also present on the PCB.

**MSP-FET430U64:** One MSP-TS430PM64 Target Socket module. This is the PCB on which is mounted a 64-pin ZIF socket. It fits all MSP430 devices in 64 pin PM-Package. A 2x7 pin male connector is also present on the PCB.

**MSP-FET430U80:** One MSP-TS430PN80 Target Socket module. This is the PCB on which is mounted a 80-pin ZIF socket. It fits all MSP430 devices in 80 pin PN-Package. A 2x7 pin male connector is also present on the PCB.

**MSP-FET430U100:** One MSP-TS430PZ100 Target Socket module. This is the PCB on which is mounted a 100-pin ZIF socket. It fits all MSP430 devices in 100 pin PZ-Package. A 2x7 pin male connector is also present on the PCB.

One USB-Cable

One 14-conductor cable

**MSP-FET430U28:** Four PCB 1x14 pin headers (Two male and two female).

**MSP-FET430U48:** Four PCB 2x24 pin headers (Two male and two female).

**MSP-FET430U64:** Eight PCB 1x16 pin headers (Four male and four female).

**MSP-FET430U80:** Eight PCB 1x20 pin headers (Four male and four female).

**MSP-FET430U100:** Eight PCB 1x25 pin headers (Four male and four female).

One small box containing two or four MSP430 device samples.

**MSP-FET430U28:** MSP430F1231DW and/or MSP430F1232IDW

**MSP-FET430U48:** MSP430F4270IDL

**MSP-FET430U64:** MSP430F4171PM and MSP430F1691PM

**MSP-FET430U80:** MSP430FG439

**MSP-FET430U100:** MSP430F4491PZ

Consult the device data sheets for device specifications. A list of device errata can be found at <http://www.ti.com/sc/cgi-bin/buglist.cgi>

## 1.5 Software Installation

Follow the instructions on the supplied READ ME FIRST document to install the IAR Embedded Workbench Kickstart. Read the file <Installation Root>\Embedded Workbench x.x\430\doc\readme.htm from IAR for the latest information about the Workbench. The term Kickstart is used to refer to the function-limited version of Embedded Workbench (including C-SPY debugger). Kickstart is supplied on the CD-ROM included with each FET, and the latest version is available from the MSP430 web site.

The above documents (and this document) can be accessed using:  
START->PROGRAMS->IAR SYSTEMS->IAR EMBEDDED WORKBENCH  
KICKSTART FOR MSP430 V3

Kickstart is compatible with WINDOWS 98, 2000, ME, NT4.0, and XP. However, the USB-FET-Interface works only with WINDOWS 2000 and XP.

## 1.6 Hardware Installation, MSP-FET430X110

- 1) Connect the 25-conductor cable originating from the FET to the parallel port of your PC.
- 2) Ensure that the MSP430F1121AIDW is securely seated in the socket, and that its pin 1 (indicated with a circular indentation on the top surface) aligns with the "1" mark on the PCB.
- 3) Ensure that jumpers J1 (near the non-socketed IC on the FET) and J5 (near the LED) are in place. Pictorials of the FET and its parts are presented in Appendix B.

## 1.7 Hardware Installation, MSP-FET430Pxx0 ('P120, 'P140, 'P410, 'P430, 'P440)

- 1) Use the 25-conductor cable to connect the FET Interface module to the parallel port of your PC.

- 2) Use the 14-conductor cable to connect the FET Interface module to the supplied Target Socket module.
- 3) Ensure that the MSP430 device is securely seated in the socket, and that its pin 1 (indicated with a circular indentation on the top surface) aligns with the “1” mark on the PCB.
- 4) Ensure that the two jumpers (LED and  $V_{CC}$ ) near the 2x7 pin male connector are in place. Pictorials of the Target Socket module and its parts are presented in Appendix B.

## 1.8 Hardware Installation, MSP-FET430UIF

Use the USB cable to connect the USB-FET Interface module to a USB port of your PC. The USB FET should be recognized instantly as the USB device driver should have been installed already with the Kickstart SW. If for any reason the Install Wizard starts, respond to the prompts and point the wizard to the driver files which are located in directory: <Installation Root>\Embedded Workbench x.x\430\bin\WinXP. Detailed driver installation instructions can be found in Appendix F.

After connecting to a PC, the USB FET performs a selftest where the red LED flashes for about two seconds. If the selftest passed successfully, the green LED lights permanently.

Use the 14-conductor cable to connect the USB-FET Interface module to a target board, such as an MSP-TS430xxx Target Socket Module.

Ensure that the MSP430 device is securely seated in the socket and that its pin 1 (indicated with a circular indentation on the top surface) aligns with the “1” mark on the PCB.

Ensure that the two jumpers (LED and  $V_{CC}$ ) near the 2x7 pin male connector are in place. Pictorials of the MSP430 Target Socket modules and their parts are presented in Appendix B.

The USB FET has additional features like: programming of the security fuse and adjustable target  $V_{CC}$  (1.8 V – 5 V); target can be supplied with up to 100mA.

## 1.9 “Flash”ing the LED

This section demonstrates on the FET the equivalent of the C-language “Hello world!” introductory program; an application that flashes the LED is developed and downloaded to the FET and then run.

- 1) Start the Workbench (START->PROGRAMS->IAR SYSTEMS->IAR EMBEDDED WORKBENCH KICKSTART FOR MSP430 V3->IAR EMBEDDED WORKBENCH).
- 2) Use FILE->OPEN WORKSPACE to open the file at: <Installation Root>\Embedded Workbench x.x\430\FET\_examples\fet\_projects.eww. The workspace window will open.
- 3) Click on the tab at the bottom of the workspace window that corresponds to your tool (FETxxx) and desired language (assembler or C).

- 4) Use PROJECT->OPTIONS->FET Debugger->Setup->Connection to select the appropriate port: LPTx for the parallel FET Interface or Texas Instruments USB FET for the USB Interface.
- 5) Use PROJECT->REBUILD ALL to build and link the source code. You can view the source code by double-clicking on the project, and then double-clicking on the displayed source file.
- 6) Use PROJECT->DEBUG to start the C-SPY debugger. C-SPY will erase the device Flash, and then download the application object file to the device Flash.

See the FAQ, Debugging #1) if C-SPY is unable to communicate with the device.

- 7) Use DEBUG->GO to start the application. The LED should flash!
- 8) Use DEBUG->STOP DEBUGGING to stop debugging, to exit C-SPY, and to return to the Workbench.
- 9) Use FILE->EXIT to exit the Workbench.

Congratulations, you've just built and tested your first MSP430 application!

## 1.10 Important MSP430 Documents on the CD-ROM and WEB

The primary sources of MSP430 information are the device specific data sheet and User's Guide. The most up to date versions of these documents available at the time of production have been provided on the CD-ROM included with this tool. The MSP430 web site ([www.ti.com/msp430](http://www.ti.com/msp430)) contains the latest version of these documents.

From the MSP430 main page on the CD-ROM, navigate to: Literature->MSP430 Literature->Data Sheets, to access the MSP430 device data sheets.

From the MSP430 main page on the CD-ROM, navigate to: Literature->MSP430 Literature->User's Guides, to access the MSP430 device User's Guides and tools.

Documents describing the IAR tools (Workbench/C-SPY, the assembler, the C compiler, the linker, and the librarian) are located in common\doc and 430\doc. The documents are in PDF-format. Supplements to the documents (i.e., the latest information) are available in HTML-format within the same directories. 430\doc\readme\_start.htm provides a convenient starting point for navigating the IAR documentation.

# Development Flow

---

---

---

This chapter discusses how to use Kickstart to develop your application software and how to use C-SPY to debug it.

<b>Topic</b>	<b>Page</b>
2.1 Overview	2-2
2.2 Using Kickstart	2-2
2.2.1 Project Settings	2-3
2.2.2 Creating a Project from Scratch	2-5
2.2.3 Using an Existing IAR V1.x/V2.x Project	2-6
2.2.4 Stack Management within the .xcl Files	2-6
2.2.5 How to Generate Texas Instruments .TXT (and other format) Files	2-7
2.2.6 Overview of Example Programs	2-7
2.3 Using C-SPY	2-8
2.3.1 Breakpoint Types	2-8
2.3.2 Using Breakpoints	2-8
2.3.3 Using Single Step	2-9
2.3.4 Using Watch Windows	2-10

## 2.1 Overview

Applications are developed in assembler and/or C using the Workbench, and they are debugged using C-SPY. C-SPY is seamlessly integrated into the Workbench. However, it is more convenient to make the distinction between the code development environment (Workbench) and the debugger (C-SPY). C-SPY can be configured to operate with the FET (i.e., an actual MSP430 device), or with a software simulation of the device. Kickstart is used to refer to the Workbench and C-SPY collectively. The Kickstart software tools are a product of IAR.

Documentation for the MSP430 family and Kickstart is extensive. The CD-ROM supplied with this tool contains a large amount of documentation describing the MSP430. The MSP430 home page ([www.ti.com/msp430](http://www.ti.com/msp430)) is another source of MSP430 information. The components of Kickstart (workbench/debugger, assembler, compiler, linker) are fully documented in <Installation Root>\Embedded Workbench x.x\common\doc and <Installation Root>\Embedded Workbench\430\doc. .htm files located throughout the Kickstart directory tree contain the most up to date information and supplement the .pdf files. In addition, Kickstart documentation is available on-line via HELP.

Read Me Firsts from IAR and Texas Instruments and this document can be accessed using:

START->PROGRAMS->IAR SYSTEMS->IAR EMBEDDED WORKBENCH  
KICKSTART FOR MSP430 V3

Tool	User's Guide	Most Up To Date Information
Workbench/C-SPY	EW430_UsersGuide.pdf	readme.htm, ew430.htm, cs430.htm, cs430f.htm,
Assembler	EW430_AssemblerReference.pdf	a430.htm, a430_msg.htm
Compiler	EW430_CompilerReference.pdf	icc430.htm, icc430_msg.htm
C library		CLibrary.htm
Linker and Librarian	xlink.pdf	xlink.htm, xman.htm, xar.htm

## 2.2 Using Kickstart

The Kickstart development environment is function-limited. The following restrictions are in place:

The C compiler will not generate an assembly code list file.

The linker will link a maximum of 4K bytes of code originating from C source (but an unlimited amount of code originating from assembler source).

The simulator will input a maximum of 4K bytes of code.

A "Full" (i.e., unrestricted) version of the software tools can be purchased from IAR. A mid-featured tool set – called "Baseline", with a 12K byte C code size limitation and basic floating-point operations – is also available from IAR. Consult the IAR web site ([www.iar.se](http://www.iar.se)) for more information.

## 2.2.1 Project Settings

The settings required to configure the Workbench and C-SPY are numerous and detailed. Read and thoroughly understand the documentation supplied by IAR when dealing with project settings. Review the project settings of the supplied assembler and C examples; the project settings are accessed using: PROJECT->OPTIONS with the project name selected. Use these project settings as templates when developing your own projects. Note that if the project name is not selected when settings are made, the settings will be applied to the selected file (and not to the project).

The following project settings are recommended/required:

- 1) Specify the target device (GENERAL OPTIONS->TARGET->DEVICE)
- 2) Enable an assembler project or a C/assembler project (GENERAL OPTIONS->TARGET->ASSEMBLER ONLY PROJECT)
- 3) Enable the generation of an executable output file (GENERAL OPTIONS->OUTPUT->OUTPUT FILE->EXECUTABLE)
- 4) In order to easily debug a C project, disable optimization (C/C++ Compiler->CODE->OPTIMIZATIONS->SIZE->NONE (BEST DEBUG SUPPORT))
- 5) Enable the generation of debug information in the compiler output (C/C++ Compiler ->OUTPUT->GENERATE DEBUG INFO)
- 6) Specify the search path for the C preprocessor (C/C++ Compiler->PREPROCESSOR->INCLUDE PATHS)
- 7) Enable the generation of debug information in the assembler output (ASSEMBLER->OUTPUT->GENERATE DEBUG-INFO)
- 8) Specify the search path for the assembler preprocessor (ASSEMBLER ->PREPROCESSOR->INCLUDE PATHS)
- 9) In order to debug the project using C-SPY, specify a compatible format (LINKER->OUTPUT->FORMAT->DEBUG INFO [WITH TERMINAL IO])
- 10) Specify the search path for any used libraries (LINKER->CONFIG->SEARCH PATHS)
- 11) Specify the C-SPY driver. Select PROJECT->OPTIONS->Debugger->Setup->Driver->FET Debugger to debug on the FET (i.e., MSP430 device). Select SIMULATOR to debug on the simulator. If FET Debugger is selected, use PROJECT->OPTIONS->FET Debugger->Setup->Connection to select the appropriate port: LPTx for the parallel FET interface or Texas Instruments USB FET for the USB Interface.
- 12) Enable the Device Description file. This file makes C-SPY “aware” of the specifics of the device it is debugging. This file will correspond to the specified target device (DEBUGGER->SETUP->DEVICE DESCRIPTION->OVERRIDE DEFAULT)
- 13) Enable the erasure of the Main and Information memories before object code download (FET DEBUGGER->SETUP->DOWNLOAD CONTROL->ERASE MAIN AND INFORMATION MEMORY)

- 14) In order to maximize system performance during debug, disable Virtual Breakpoints (FET DEBUGGER->SETUP ->USE VIRTUAL BREAKPOINTS), and disable all System Breakpoints (FET DEBUGGER->SETUP ->SYSTEM BREAKPOINTS ON)

**Note: Use of Factory Settings to quickly configure a project**

It is possible to use the Factory Settings button to quickly configure a project to a usable state.

The following steps can be used to quickly configure a project:

Note: The GENERAL OPTIONS tab does not have a FACTORY SETTINGS button

- 1) Specify the target device (GENERAL OPTIONS ->TARGET->DEVICE)
- 2) Enable an assembler project or a C/assembler project (GENERAL OPTIONS ->TARGET->ASSEMBLER ONLY PROJECT)
- 3) Enable the generation of an executable output file (GENERAL OPTIONS ->OUTPUT->OUTPUT FILE->EXECUTABLE)
- 4) Accept the factory settings for the compiler (C/C++ COMPILER->FACTORY SETTINGS)
- 5) Accept the factory settings for the assembler (ASSEMBLER->FACTORY SETTINGS)
- 6) Accept the factory settings for the linker (LINKER->FACTORY SETTINGS)
- 7) Accept the factory settings for C-SPY (DEBUGGER->FACTORY SETTINGS)
- 8) To debug on the hardware, select DEBUGGER ->SETUP->DRIVER->FET DEBUGGER
- 9) Specify the active parallel port used to interface to the FET if not LPT1 (FET DEBUGGER ->SETUP->CONNECTION->LPTx) or specify the USB port (FET DEBUGGER ->SETUP->CONNECTION->TI USB FET)

**Note: Avoid the use of absolute pathnames when referencing files.**

Instead, use the relative pathname keywords \$TOOLKIT\_DIR\$ and \$PROJ\_DIR\$. See the IAR documentation for a description of these keywords. The use of relative pathnames will permit projects to be moved easily and projects will not require modification when IAR systems are upgraded (say, from Kickstart, or Baseline, to Full).

## 2.2.2 Creating a Project from Scratch

The following section presents step-by-step instructions to create an assembler or C project from scratch, and to download and run the application on the MSP430. See the Project Settings section above. Also, the MSP430 IAR Embedded Workbench IDE User Guide presents a more comprehensive overview of the process.

- 1) Start the Workbench (START->PROGRAMS->IAR SYSTEMS->IAR EMBEDDED WORKBENCH KICKSTART FOR MSP430 V3->KICKSTART IAR EMBEDDED WORKBENCH).
- 2) Create a new text file (FILE->NEW->SOURCE/TEXT).
- 3) Enter the program text into the file.

**Note: Use .h files to simplify your code development**

Kickstart is supplied with files for each device that define the device registers and the bit names, and these files can greatly simplify the task of developing your program. The files are located in <Installation Root>\Embedded Workbench x.x\430\inc. Simply include the .h file corresponding to your target device in your text file (#include "msp430xyyy.h"). Additionally, files io430xxxx.h are provided, and are optimized to be included by C source files.

- 4) Save the text file (FILE->SAVE).

It is recommended that assembler text file be saved with a file type suffix of ".s43", and that C text files be saved with a file type suffix of ".c".

- 5) Create a new workspace (FILE->NEW->WORKSPACE). Specify a workspace name and press SAVE.
- 6) Create a new project (PROJECT->CREATE NEW PROJECT). Specify a project name and press CREATE
- 7) Add the text file to the project (PROJECT->ADD FILES). Select the text file and press OPEN. Alternatively, double-click on the text file to add it to the project.

**Note: How to add assembler source files to your project**

The default file type presented in the Add Files window is "C/C++ Files". In order to view assembler files (.s43), select "Assembler Files" in the "Files of type" drop-down menu.

- 8) Configure the project options (PROJECT->OPTIONS). For each of the listed subcategories (GENERAL OPTIONS, C/C++ COMPILER, ASSEMBLER, LINKER, DEBUGGER), accept the default Factory Settings with the following exceptions:
  - Specify the target device (GENERAL OPTIONS->TARGET->DEVICE)
  - Enable an assembler project or a C/assembler project (GENERAL OPTIONS ->TARGET->ASSEMBLER ONLY PROJECT)

Enable the generation of an executable output file (GENERAL OPTIONS ->OUTPUT->OUTPUT FILE->EXECUTABLE)

To debug on the FET (i.e., the MSP430), select DEBUGGER ->SETUP->DRIVER-> FET DEBUGGER

Specify the active port used to interface to the FET (FET DEBUGGER ->SETUP->CONNECTION)

- 8) Build the project (PROJECT->REBUILD ALL).
- 9) Debug the application using C-SPY (PROJECT->DEBUG). This will start C-SPY and C-SPY will get control of the target, erase the target memory, program the target memory with the application, and reset the target.

See the FAQ, Debugging #1) if C-SPY is unable to communicate with the device.

- 10) Use DEBUG->GO to start the application.
- 11) Use DEBUG->STOP DEBUGGING to stop the application, to exit C-SPY, and to return to the Workbench.
- 12) Use FILE->EXIT to exit the Workbench.

### **2.2.3 Using an Existing IAR V1.x/V2.x Project**

It is possible to use an existing project from an IAR V1.x/V2.x system with the new IAR V3.x system; refer to the IAR document *Step by step migration for EW430 x.xx*. This document can be located in: <Installation Root>\Embedded Workbench x.x\430\doc\migration.htm

### **2.2.4 Stack Management within the .xcl Files**

The .xcl files are input to the linker, and contain statements that control the allocation of device memory (RAM, Flash). Refer to the IAR XLINK documentation for a complete description of these files. The .xcl files provided with the FET (<Installation Root>\Embedded Workbench x.x\430\config\lnk430xxx.xcl) define a relocatable segment (RSEG) called CSTACK. CSTACK is used to define the region of RAM that is used for the system stack within C programs. CSTACK can also be used in assembler programs [MOV #SFE(CSTACK), SP]. CSTACK is defined to extend from the last location of RAM for 50 bytes (i.e., the stack extends downwards through RAM for 50 bytes).

Other statements in the .xcl file define other relocatable regions that are allocated from the first location of RAM to the bottom of the stack. It is critical to note that:

1. The supplied .xcl files reserve 50 bytes of RAM for the stack, regardless if this amount of stack is actually required (or if it is sufficient).
2. There is no runtime checking of the stack. The stack can overflow the 50 reserved bytes and possibly overwrite the other segments. No error will be output.

---

The supplied .xcl files can be easily modified to tune the size of the stack to the needs of the application; simply edit -D\_STACK\_SIZE=xx to allocate xx bytes for the stack. Note that the .xcl file reserves 50 bytes for the heap if required (say, by malloc()).

### 2.2.5 How to Generate Texas Instruments .TXT (and other format) Files

The Kickstart linker can be configured to output objects in Texas Instruments .TXT format for use with the GANG430 and PRGS430 programmers. Select: PROJECT->OPTIONS->LINKER->OUTPUT->FORMAT->OTHER->MSP430-TXT. Intel and Motorola formats can also be selected.

See the FAQ, Program Development #6).

### 2.2.6 Overview of Example Programs

Example programs for MSP430 devices are provided in <Installation Root>\Embedded Workbench x.x\430\FET\_examples. Each tool folder contains folders that contain the assembler and C sources.

<Installation Root>\Embedded Workbench\x.x\430\FET\_examples\fet\_projects.eww conveniently organizes the FET\_1 demonstration code into a workspace. The workspace contains assembler and C projects of the code for each of the FET tools. Debug and Release versions are provided for each of the projects.

<Installation Root>\Embedded Workbench x.x\430\FET\_examples\code\_examples.eww conveniently organizes the code examples into a workspace. The workspace contains assembler and C projects of the code for each of the FET tools. Debug and Release versions are provided for each of the projects.

<Installation Root>\Embedded Workbench x.x\430\FET\_examples\contents.htm conveniently organizes and documents the examples.

Additional code examples can be found on the MSP430 home page under Design Resources.

<p><b>Note:</b> Some example programs require a 32KHz crystal on LFXT1, and not all FETs are supplied with a 32KHz crystal.</p>
---

## 2.3 Using C-SPY

Refer to Appendix C for a description of FET-specific menus within C-SPY.

### 2.3.1 Breakpoint Types

The C-SPY breakpoint mechanism makes use of a limited number of on-chip debugging resources (specifically, N breakpoint registers, see Table 2-1). When N or fewer breakpoints are set, the application runs at full device speed (or “Realtime”). When greater than N breakpoints are set and Use Virtual Breakpoints is enabled (FET DEBUGGER->SETUP->USE VIRTUAL BREAKPOINTS), the application runs under the control of the host PC; the system operates at a much slower speed, but offers unlimited software breakpoint (or “Non-Realtime”). During Non-Realtime mode, the PC effectively repeatedly single steps the device and interrogates the device after each operation to determine if a breakpoint has been hit.

Both (code) address and data (value) breakpoints are supported. Data breakpoints and range breakpoints each require two address breakpoints.

Table 2-1. Number of Device Breakpoints and Other Emulation Features

Device	Breakpoints (N)	Range Breakpoints	Clock Control	State Sequencer	Trace Buffer
MSP430F11x1	2				
MSP430F11x2	2				
MSP430F12x	2				
MSP430F12x2	2				
MSP430F13x	3	X			
MSP430F14x	3	X			
MSP430F15x	8	X	X	X	X
MSP430F16x	8	X	X	X	X
MSP430F161x	8	X	X	X	X
MSP430F41x	2		X		
MSP430F42x	2		X		
MSP430F43x	8	X	X	X	X
MSP430F44x	8	X	X	X	X
MSP430FE42x	2		X		
MSP430FG43x	2		X		
MSP430FW42x	2		X		

### 2.3.2 Using Breakpoints

If C-SPY is started with greater than N breakpoints set and virtual breakpoints are disabled, a message will be output that informs the user that only N (Realtime) breakpoints are enabled (and one or more breakpoints are disabled). Note that the workbench permits any number of breakpoints to be set, regardless of the USE VIRTUAL BREAKPOINTS setting of C-SPY. If virtual breakpoints are disabled, a maximum of N breakpoints can be set within C-SPY.

RESET'ing a program temporarily requires a breakpoint if PROJECT->OPTIONS->DEBUGGER->SETUP->RUN TO is enabled. See the FAQ, Debugging #30).

The RUN TO CURSOR operation temporarily requires a breakpoint. Consequently, only N-1 breakpoints can be active when RUN TO CURSOR is used if virtual breakpoints are disabled. See the FAQ, Debugging #31).

If, while processing a breakpoint, an interrupt becomes active, C-SPY will stop at the first instruction of the interrupt service routine. See the FAQ, Debugging #24).

### 2.3.3 Using Single Step

When debugging an assembler file, STEP OVER, STEP OUT, and NEXT STATEMENT operate like STEP INTO; the current instruction is executed at full speed.

When debugging an assembler file, a step operation of a CALL instruction stops at the first instruction of the CALL'ed function.

When debugging an assembler file, a (true) STEP OVER a CALL instruction that executes the CALL'ed function at full device speed can be synthesized by placing a breakpoint after the CALL and GO'ing (to the breakpoint in "Realtime mode").

When debugging a C file, a single step (STEP) operation executes the next C statement. Thus, it is possible to step over a function reference. If possible, a hardware breakpoint will be placed after the function reference and a GO will be implicitly executed. This causes the function to be executed at full speed. If no hardware breakpoints are available, the function will be executed in Non-Realtime mode. STEP INTO is supported. STEP OUT is supported.

Within Disassembly mode (VIEW->DISASSEMBLY), a step operation of a non-CALL instruction executes the instruction at full device speed.

Within Disassembly mode (VIEW->DISASSEMBLY), a step operation of a CALL instruction will place – if possible - a hardware breakpoint after the CALL instruction and then execute GO. The CALL'ed function executes at full device speed. If no hardware breakpoint is available prior to the GO, the CALL'ed function will be executed in Non-Realtime mode. In either case, execution will stop at the instruction following the CALL.

It is only possible to single step when source statements are present. Breakpoints must be used when running code for which there is no source code (i.e., place the breakpoint after the CALL to the function for which there is no source, and then GO to the breakpoint in "Realtime mode").

If, during a single step operation, an interrupt becomes active, the current instruction is completed and C-SPY stops at the first instruction of the interrupt service routine. See the FAQ, Debugging #24).

### 2.3.4 Using Watch Windows

The C-SPY Watch Window mechanism permits C variables to be monitored during the debugging session. Although not originally designed to do so, the Watch Window mechanism can be extended to monitor assembler variables.

Assume that the variables to watch are defined in RAM, say:

```
RSEG DATA16_I
varword ds 2 ; two bytes per word
varchar ds 1 ; one byte per character
```

In C-SPY:

- 1) Open the Watch Window: VIEW->WATCH
- 2) Use DEBUG->QUICK WATCH
- 3) To watch varword, enter in the Expression box:  
(\_\_data16 unsigned int \*) #varword
- 4) To watch varchar, enter in the Expression box:  
(\_\_data16 unsigned char \*) #varchar
- 5) Press the Add Watch button
- 6) Close the Quick Watch window
- 7) For the created entry in the Watch Window, click on the + symbol. This displays the contents (or value) of the watched variable.

To change the format of the displayed variable (default, binary, octal, decimal, hex, char), select the type, click the right mouse button, and then select the desired format. The value of the displayed variable can be changed by selecting it, and then entering the new value.

In C, variables can be watched by selecting them and then dragging-n-dropping them into the Watch Window.

Since the MSP430 peripherals are memory mapped, it is possible to extend the concept of watching variables to watching peripherals. Be aware that there may be side effects when peripherals are read and written by C-SPY. See the FAQ, Debugging #22).

CPU core registers can be specified for watching by preceding their name with '#' (i.e., #PC, #SR, #SP, #R5, etc.).

Variables watched within the Watch Window are only updated when C-SPY gets control of the device (say, following a breakpoint hit, a single step, or a STOP/escape).

Although registers can be monitored in the Watch Window, VIEW->REGISTER is a superior method.

# Design Considerations for In-Circuit Programming

---

---

---

This chapter presents signal requirements for in-circuit programming of the MSP430.

<b>Topic</b>	<b>Page</b>
<b>3.1 Bootstrap Loader</b>	<b>3-2</b>
<b>3.2 External Power</b>	<b>3-2</b>
<b>3.3 Device Signals</b>	<b>3-3</b>
<b>3.4 Signal Connections for In-System Programming and Debugging, MSP-FET430X110</b>	<b>3-4</b>
<b>3.5 Signal Connections for In-System Programming and Debugging, MSP-FETP430IF, MSP-FET430UIF</b>	<b>3-6</b>

### 3.1 Bootstrap Loader

The JTAG pins provide access to the Flash memory of the MSP430F device. On some devices, these pins must be “shared” with the device port pins, and this sharing of pins can complicate a design (or it may simply not be possible to do so). As an alternative to using the JTAG pins, MSP430F devices contain a program (a “Bootstrap Loader”) that permits the Flash memory to be erased and programmed simply, using a reduced set of signals. Application Notes SLAA089 and SLAA096 fully describe this interface. Texas Instruments does not produce a BSL tool. However, customers can easily develop their own BSL tools using the information in the Application Notes, or BSL tools can be purchased from 3<sup>rd</sup> parties. See the MSP430 web site for the application notes and a list of MSP430 3<sup>rd</sup> party tool developers.

Texas Instruments suggests that MSP430Fxxx customers design their circuits with the BSL in mind (i.e., we suggest providing access to these signals, e.g. via a header). See the Device Signals section.

See the FAQ, Hardware #9) for a second alternative to sharing the JTAG and port pins.

### 3.2 External Power

The PC parallel port can source a limited amount of current. Owing to the ultra low power requirement of the MSP430, a stand-alone FET does not exceed the available current. However, if additional circuitry is added to the tool, this current limit could be exceeded. In this case, external power can be supplied to the tool via connections provided on the MSP-FET430X110 and the Target Socket modules. See the schematics and pictorials of the MSP-FET430X110 and the Target Socket modules presented in Appendix B to locate the external power connectors.

The USB-IF can supply targets with up to 100 mA through pin 2 of the 14-pin connector.  $V_{CC}$  for the target can be selected between 1.8 V and 5 V in steps of 0.1 V. Alternatively the target can be supplied externally. Then the external voltage should be connected to pin 4 of the 14-pin connector. The USB-IF then adjusts the level of the JTAG signals to external  $V_{CC}$  automatically. Only pin 2 (USB-IF supplies target) OR pin 4 (target is externally supplied) should be connected, not both at the same time.

To connect 20-pin MSP430 devices to the USB-IF, the 28pin socket module MSP-TS430DW28, which is part of the MSP-FET430P120-kit, should be used. Pin 1 of the 20-pin device should align with pin 1 of the 28-pin socket.

When an MSP-FET430X110 is powered from an external supply, an on-board device regulates the external voltage to the level required by the MSP430.

When a Target Socket module is powered from an external supply, the external supply powers the device on the Target Socket module and any user circuitry connected to the Target Socket module and the FET Interface module continues to be powered from the PC via the parallel port. If the externally supplied voltage differs from that of the FET Interface module, the Target Socket module **must** be modified so that the externally supplied voltage is routed to the FET Interface module (so that it may adjust its output voltage levels accordingly). Again, see the Target Socket module schematic in Appendix B.

### 3.3 Device Signals

The following device signals should be brought out (i.e., made accessible) so that the FET, GANG430, and PRGS430 tools can be utilized:

- RST/NMI
- TMS
- TCK
- TDI
- TDO
- GND
- VCC
- TEST†

**Notes: Design considerations to support the FET, GANG430, and PRGS430**

- 1) Connections to XIN and XOUT are not required, and should not be made.
- 2) PRGS430 software Version 1.10 or greater must be used.

The BSL tool requires the following device signals:

- RST/NMI
- TCK
- GND
- VCC
- P1.1
- P2.2 or P1.0‡
- TEST†

† If present on device.

‡ '1xx devices use pins P1.1 and P2.2 for the BSL. '4xx devices use pins P1.0 and P1.1 for the BSL.

### 3.4 Signal Connections for In-System Programming and Debugging, MSP-FET430X110

With the proper connections, you can use the C-SPY debugger and the MSP-FET430X110 to program and debug code on your own target board. In addition, the connections support the GANG430 and PRGS430, thus providing an easy way to program prototype boards, if desired.

Figure 3-1 shows the connections between the FET and the target device required to support in-system programming and debugging using C-SPY. If your target board has its own local power supply, such as a battery, do not connect Vcc to pin 2 of the JTAG header. Otherwise, contention may occur between the FET and your local power supply.

The figure shows a 14-pin header being used for the connections on your target board. It is recommended that you build a wiring harness from the FET with a connector which mates to the 14-pin header and mount the 14-pin header on your target board. This allows you to unplug your target board from the FET as well as use the GANG430 or PRGS430 to program prototype boards, if desired.

The signals required are routed on the FET to header locations for easy access. Refer to the device datasheet (for pin numbers) and the schematic and PCB information in Appendix B to locate the signals.

After you make the connections from the FET to your target board, remove the MSP430 device from the socket on the FET so that it does not conflict with the MSP430 device in your target board. Now simply use C-SPY as you would normally to program and debug.

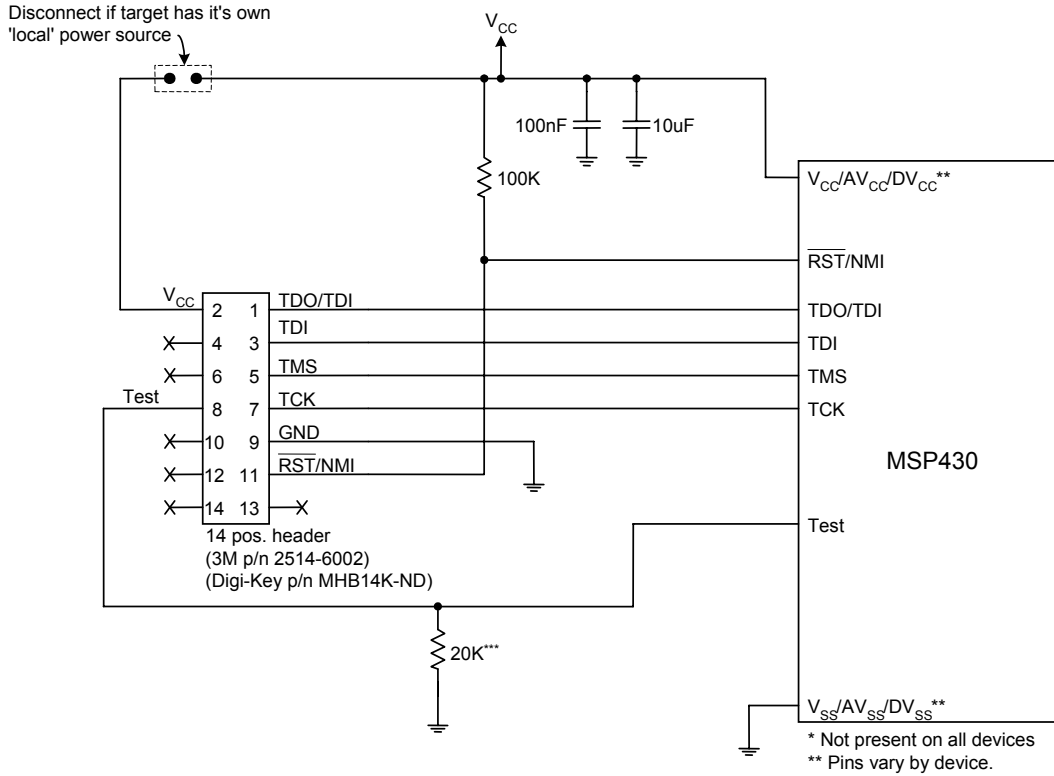

\*\*\* Pulldown not required on all devices.  
Check device datasheet pin description.

**Note: Connection to XOUT is not required**

No JTAG connection is required to the XOUT pin of the MSP430 as shown on some schematics.

Figure 3-1. Signal Connections for MSP-FET430X110

### 3.5 Signal Connections for In-System Programming and Debugging, MSP-FETP430IF, MSP-FET430UIF

With the proper connections, you can use the C-SPY debugger and an FET hardware JTAG interface such as the MSP-FETP430IF and MSP-FET430UIF to program and debug code on your own target board. In addition, the connections support the GANG430 or PRGS430, thus providing an easy way to program prototype boards, if desired.

Figure 3-2 shows the connections between the FET Interface module and the target device required to support in-system programming and debugging using C-SPY. The figure shows a 14-pin connected to the MSP430. With this header mounted on your target board, the FET Interface module can be plugged directly into your target. Then simply use C-SPY as you would normally to program and debug.

The connections for the FET Interface module and the GANG430 or PRGS430 are identical. Both the FET Interface module and GANG430 can supply  $V_{CC}$  to your target board (via pin 2). In addition, the FET Interface module and GANG430 have a  $V_{CC}$  sense feature that, if used, requires an alternate connection (pin 4 instead of pin 2). The  $V_{CC}$  sense feature senses the local  $V_{CC}$  (present on the target board, i.e., a battery or other 'local' power supply) and adjusts the output signals accordingly. If the target board is to be powered by a local  $V_{CC}$ , then the connection to pin 4 on the JTAG should be made, and not the connection to pin 2. This utilizes the  $V_{CC}$ -sense feature and prevents any contention that might occur if the local on-board  $V_{CC}$  were connected to the  $V_{CC}$  supplied from the FET Interface module or the GANG430. If the  $V_{CC}$ -sense feature is not necessary (i.e., the target board is to be powered from the FET Interface module or the GANG430) the  $V_{CC}$  connection is made to pin 2 on the JTAG header and no connection is made to pin 4. Figure 3-2 shows a jumper block in use. The jumper block supports both scenarios of supplying  $V_{CC}$  to the target board. If this flexibility is not required, the desired  $V_{CC}$  connections may be hard-wired eliminating the jumper block.

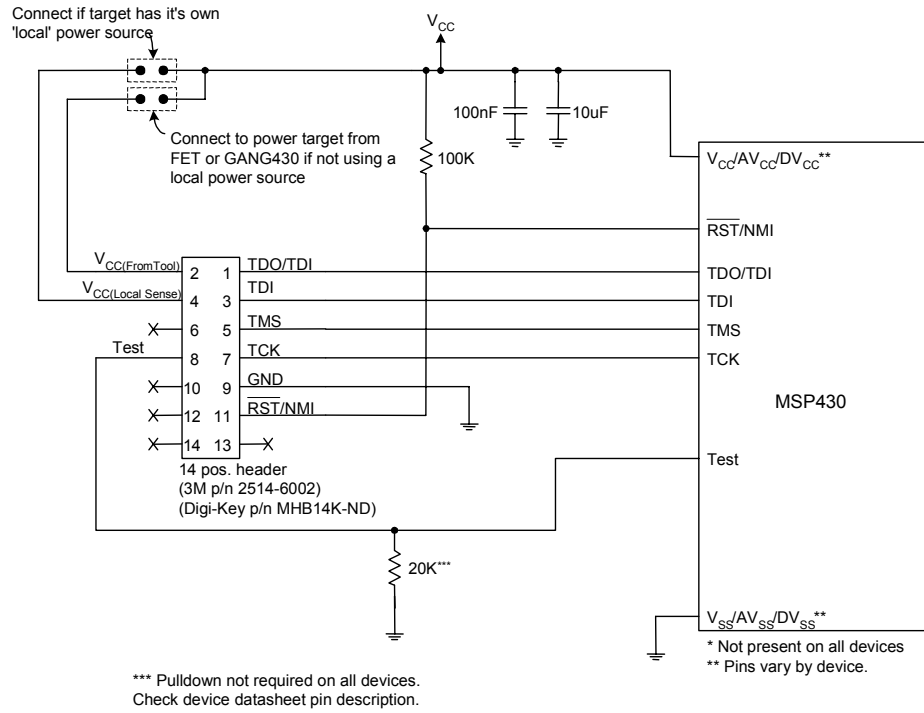

**Note: Connection to XOUT is not required**

No JTAG connection is required to the XOUT pin of the MSP430 as shown on some schematics.

Figure 3-2. JTAG Signal Connections

# Frequently Asked Questions

---

---

---

This appendix presents solutions to frequently asked questions regarding hardware, program development, and debugging tools.

<b>Topic</b>	<b>Page</b>
<b>A.1 Hardware</b>	<b>A-2</b>
<b>A.2 Program Development (Assembler, C-Compiler, Linker)</b>	<b>A-3</b>
<b>A.3 Debugging (C-SPY)</b>	<b>A-5</b>

## A.1 Hardware

- 1) **The state of the device** (CPU registers, RAM memory, etc.) **is undefined following a reset**. Exceptions to the above statement are that the PC is loaded with the word at 0xffff (i.e., the reset vector), the status register is cleared, and the peripheral registers (SFRs) are initialized as documented in the device Family User's Guides. C-SPY resets the device after programming it.
- 2) When the MSP-FET430X110 is used as an interface to an MSP430 on the user's circuit (i.e., there is no MSP430 device in the FET socket), **the XOUT and XIN signals from the FET should not be connected to the corresponding pins of the in-circuit MSP430**. Similarly, when using the interface module, do not connect the XOUT and XIN signals from the interface module to the corresponding pins of the in-circuit MSP430.
- 3) The 14-conductor **cable** connecting the FET interface module and the Target Socket module **must not exceed 8 inches (20 centimeters) in length**.
- 4) The signal assignment on the **14-conductor cable** is **identical** for the **parallel port interface** and the **USB FET**.
- 5) **To utilize the on-chip ADC voltage references, C6** (10  $\mu$ F, 6.3 V, low leakage) **must be installed** on the Target Socket module.
- 6) **Crystals/resonators Q1 and Q2** (if applicable) **are not provided** on the Target Socket module. For MSP430 devices which contain user selectable loading capacitors, the effective capacitance is the selected capacitance plus 3 pF (pad capacitance) divided by two.
- 7) **Crystals/resonators have no effect upon the operation of the tool and C-SPY** (as any required clocking/timing is derived from the internal DCO/FLL).
- 8) **On 20-pin and 28-pin devices** with multiplexed port/JTAG pins (P1.4-P1.7), **it is required that "RELEASE JTAG ON GO" be selected in order to use these pins in their port capacity**. See C.1.1 EMULATOR->RELEASE JTAG ON GO for additional information regarding this mechanism.
- 9) **As an alternative to sharing the JTAG and port pins** (on 20 and 28 pin devices), **consider using an MSP430 device that is a "superset" of the smaller device**. A very powerful feature of the MSP430 is that the family members are code and architecturally compatible, so code developed on one device (say, without shared JTAG and port pins) will port effortlessly to another (assuming an equivalent set of peripherals).
- 10) **Information Memory may not be blank** (erased to 0xff) when the device is delivered from Texas Instruments. Customers should erase the Information Memory before its first usage. Main Memory of packaged devices is blank when the device is delivered from Texas Instruments.
- 11) **The device current increases by approximately 10  $\mu$ A when a device in low power mode is stopped** (using ESC), **and then the**

**low power mode is restored** (using GO). This behavior appears to happen on all devices except the MSP430F12x.

12) The following **ZIF sockets** are used in the FET tools and Target Socket modules:

- 20-pin device (DW package): Wells-CTI 652 D020
- 28-pin device (DW package): Wells-CTI 652 D028
- 48-pin device (DL package): Yamaichi IC51-0482-1163
- 64-pin device (PM package): Yamaichi IC51-0644-807
- 80-pin device (PN package): Yamaichi IC201-0804-014
- 100-pin device (PZ package): Yamaichi IC201-1004-008

Wells-CTI: <http://www.wellscti.com/>

Yamaichi: <http://www.yamaichi.us/>

## A.2 Program Development (Assembler, C-Compiler, Linker)

- 1) **The files supplied in the 430\tutor folder work only with the simulator.** Do not use the files with the FET. See the FAQ: Program Development #11)
- 2) **A common MSP430 “mistake” is to fail to disable the Watchdog mechanism;** the Watchdog is enabled by default, and it will reset the device if not disabled or properly handled by your application. See the FAQ, Program Development #14).
- 3) **When adding source files to a project, do not add files that are included by source files that have already been added to the project** (say, an .h file within a .c or .s43 file). These files will be added to the project file hierarchy automatically.
- 4) **In assembler, enclosing a string in double-quotes (“string”) automatically appends a zero byte** to the string (as an “End Of String” marker). Enclosing a string in single-quotes (‘string’) does not.
- 5) When using the compiler or the assembler, **if the last character of a source line is backslash (\), the subsequent carriage return/line feed is ignored** (i.e., it is as if the current line and the next line are a single line). When used in this way, the backslash character is a “Line Continuation” character.
- 6) **The linker output format must be “Debug info” or “Debug info with terminal I/O” (.d43) for use with C-SPY.** C-SPY will not start otherwise, and an error message will be output. C-SPY cannot input a .TXT file.
- 7) **Position Independent code can be generated** (using PROJECT->OPTIONS->GENERAL OPTIONS->TARGET->POSITION-INDEPENDENT CODE).
- 8) **Within the C libraries, GIE (Global Interrupt Enable) is disabled before** (and restored after) **the hardware multiplier is used.** Contact Texas Instruments if you wish the source code for these libraries so that this behavior can be disabled.

- 9) **It is possible to mix assembler and C programs within the Workbench.** Refer to the Assembler Language Interface chapter of the C/C++ Compiler Reference Guide from IAR.
- 10) The Workbench can produce an object file in Texas Instruments .TXT format. **C-SPY cannot input an object file in Texas Instruments .TXT format.**
- 11) **The example programs giving in the Kickstart documentation (i.e., Demo, Tutor, etc.) are not correct.** The programs works only in the simulator. However, the programs will not function correctly on an actual device because the Watchdog mechanism is active. The programs need to be modified to disable the Watchdog mechanism. Disable the Watchdog mechanism with the C-statement: "WDTCTL = WDTPW + WDTHOLD;," or "mov #5a80h,&WDTCTL" in assembler.
- 12) **Access to MPY using an 8-bit operation is flagged as an error.** Within the .h files, 16-bit registers are defined in such a way that 8-bit operations upon them are flagged as an error. This "feature" is normally a good thing and can catch register access violations. However, in the case of MPY, it is also valid to access this register using 8-bit operators. If 8-bit operators are used to access MPY, the access violation check mechanism can be defeated by using "MPY\_" to reference the register. Similarly, 16-bit operations on 8-bit registers are flagged.
- 13) **Constant definitions (#define) used within the .h files are effectively "reserved"** and include, for example, C, Z, N, and V. Do not create program variables with these names.
- 14) **The CSTARTUP that is implicitly linked with all C applications does not disable the Watchdog timer.** Use WDT = WDTPW + WDTHOLD; to explicitly disable the Watchdog. This statement is best placed in the \_\_low\_level\_init() function that gets executed before main().

If the Watchdog timer is not disabled and the Watchdog triggers and resets the device during CSTARTUP, **the source screen will go blank** as C-SPY is not able to locate the source code for CSTARTUP. Be aware that CSTARTUP can take a significant amount of time to execute if a large number of initialized global variables are used.

```
int __low_level_init(void)
{
    /* Insert your low-level initializations here */

    WDTCTL = WDTPW + WDTHOLD; // Stop Watchdog timer

    /*=====*/
    /* Choose if segment initialization */
    /* should be done or not. */
    /* Return: 0 to omit seg_init */
    /*          1 to run seg_init */
    /*=====*/
    return (1);
}
```

- 15) **Compiler optimization can remove unused variables and/or statements that have no effect** and can effect debugging. Optimization: NONE is supported within PROJECT->OPTIONS-

>C/C++ COMPILER->CODE->OPTIMIZATIONS. Alternatively, variables can be declared *volatile*.

- 16) **The IAR Tutorial assumes a Full or Baseline version of the Workbench.** Within a Kickstart system, it is not possible to configure the C compiler to output assembler mnemonics.
- 17) Existing **projects from an IAR 1.x system can be used within the new IAR 2.x/3.x system**; refer to the IAR document *Migration guide for EW430 x.x*. This document can be located in: <Installation Root>\Embedded Workbench x.x\430\doc\migration.htm
- 18) **Assembler projects must reference the code segment (RSEG CODE) in order to use the LINKER->PROCESSING->FILL UNUSED CODE MEMORY mechanism.** No special steps are required to use **LINKER ->PROCESSING->FILL UNUSED CODE MEMORY** with C projects.
- 19) **Numerous C and C++ libraries are provided with the Workbench:**
  - cl430d: C, 64-bit doubles
  - cl430dp: C, 64-bit doubles, position independent
  - cl430f: C, 32-bit doubles
  - cl430fp: C, 32-bit doubles, position independent
  - dl430d: C++, 64-bit doubles
  - dl430dp: C++, 64-bit doubles, position independent
  - dl430f: C++, 32-bit doubles
  - dl430fp: C++, 32-bit doubles, position independent

### A.3 Debugging (C-SPY)

- 1) **C-SPY reports that it cannot communicate with the device.**  
Possible solutions to this problem include:

Ensure that the correct PC port is selected; use PROJECT->OPTIONS->FET DEBUGGER->CONNECTIONS

Ensure that R6 on the MSP-FET430X110 and the FET Interface module has a value of 82  $\Omega$ . Early units were built using a 330- $\Omega$  resistor for R6. See the schematics and pictorials of the MSP-FET430X110 and the FET Interface module presented in Appendix B to locate R6. The FET Interface module can be opened by inserting a thin blade between the case halves, and then carefully twisting the blade so as to pry the case halves apart.

Ensure that the correct parallel port (LPT1, 2, or 3) is being specified in the C-SPY configuration; use PROJECT->OPTIONS-> FET DEBUGGER->CONNECTIONS ->PARALLEL PORT->LPT1 (default) or LPT2 or LPT3. Check the PC BIOS for the parallel port address (0x378, 0x278, 0x3bc), and the parallel port configuration (ECP, Compatible, Bidirectional, or Normal). See the FAQ, Debugging #6) later in this document. For users of IBM Thinkpads, please try port specifications LPT2 and LPT3 despite the fact that the operating system reports the parallel port is located at LPT1.

Ensure that no other software application has reserved/taken control of the parallel port (say, printer drivers, ZIP drive drivers, etc.). Such software can prevent the C-SPY/FET driver from accessing the parallel port, and, hence, communicating with the device.

It may be necessary to reboot the computer to complete the installation of the required parallel port drivers.

Ensure that the MSP430 device is securely seated in the socket (so that the “fingers” of the socket completely engage the pins of the device), and that its pin 1 (indicated with a circular indentation on the top surface) aligns with the “1” mark on the PCB.

**CAUTION: Possible Damage To Device**

**Handle devices with fine pitch pins (64/80/100 pins) using only a vacuum pick-up tool; do not use your fingers as they can easily bend the device pins and render the device useless.**

- 2) **C-SPY can download data into RAM, INFORMATION, and Flash MAIN memories.** A warning message is output if an attempt is made to download data outside of the device memory spaces.
- 3) **C-SPY can debug applications that utilize interrupts and low power modes.** See the FAQ, Debugging #24).
- 4) **C-SPY cannot access the device registers and memory while the device is running.** C-SPY will display “-“ to indicate that a register/memory field is invalid. The user must stop the device in order to access device registers and memory. Any displayed register/memory fields will then be updated.
- 5) **When C-SPY is started, the Flash memory is erased and the opened file is programmed** in accordance with the download options as set in PROJECT->OPTIONS->FET DEBUGGER->DOWNLOAD CONTROL->DOWNLOAD CONTROL. This initial erase and program operations can be disabled selecting PROJECT->OPTIONS-> FET DEBUGGER->DOWNLOAD CONTROL ->DOWNLOAD CONTROL->SUPPRESS DOWNLOAD. Programming of the Flash can be initiated manually with EMULATOR->INIT NEW DEVICE.
- 6) **The parallel port designators (LPTx) have the following physical addresses: LPT1: 378h, LPT2: 278h, LPT3: 3BCh.** The configuration of the parallel port (ECP, Compatible, Bidirectional, Normal) is not significant; ECP seems to work well. Refer FAQ, Debugging #1) for additional hints on solving communication problems between C-SPY and the device.
- 7) **C-SPY asserts RST/NMI to reset the device** when C-SPY is started and when the device is programmed. The device is also reset by the C-SPY RESET button, and when the device is manually reprogrammed (EMULATOR->INIT NEW DEVICE), and when the JTAG is resynchronized (EMULATOR->RESYNCHRONIZE JTAG). When RST/NMI is not asserted (low), C-SPY sets the logic driving RST/NMI to high-impedance and RST/NMI is pulled high via a resistor on the PCB.

RST/NMI is asserted and negated after power is applied when C-SPY is started. RST/NMI is then asserted and negated a second time after device initialization is complete.

Within C-SPY, EMULATOR->"POWER ON" RESET will cycle the power to the target to affect a reset.

- 8) **C-SPY can debug a device whose program reconfigures the function of the RST/NMI pin to NMI.**
- 9) **The level of the XOUT/TCLK pin is undefined when C-SPY resets the device.** The logic driving XOUT/TCLK is set to high-impedance at all other times.
- 10) **When making current measurements of the device, ensure that the JTAG control signals are released** (EMULATOR->RELEASE JTAG ON GO), otherwise the device will be powered by the signals on the JTAG pins and the measurements will be erroneous. See the FAQ, Debugging #12) and Hardware #11).
- 11) **Most C-SPY settings** (breakpoints, etc.) **are now preserved between sessions.**
- 12) **When C-SPY has control of the device, the CPU is ON** (i.e., it is not in low power mode) regardless of the settings of the low power mode bits in the status register. Any low power mode conditions will be restored prior to STEP or GO. Consequently, do not measure the power consumed by the device while C-SPY has control of the device. Instead, run your application using GO with JTAG released. See the FAQ, Debugging #10) and Hardware #11).
- 13) The VIEW->MEMORY->MEMORY FILL dialog of C-SPY requires **hexadecimal values** for Starting Address, Length, and Value to be **preceded with "0x"**. Otherwise the values are interpreted as decimal.
- 14) The MEMORY utility of C-SPY can be used to view the RAM, the INFORMATION memory, and the Flash MAIN memory. The MEMORY utility of C-SPY can be used to modify the RAM; **the INFORMATION memory and Flash MAIN memory cannot be modified using the MEMORY utility.** The INFORMATION memory and Flash MAIN memory can only be programmed when a project is opened and the data is downloaded to the device or when EMULATOR->INIT NEW DEVICE is selected.
- 15) **C-SPY does not permit the individual segments of the INFORMATION memory and the Flash MAIN memory to be manipulated separately;** consider the INFORMATION memory to be one contiguous memory and the Flash MAIN memory to be a second contiguous memory.
- 16) The MEMORY window correctly displays the contents of memory where it is present. However, **the MEMORY window incorrectly displays the contents of memory where there is none present.** Memory should only be used in the address ranges as specified by the device data sheet.
- 17) C-SPY utilizes the system clock to control the device during debugging. Therefore, **device counters, etc., that are clocked by the**

**Main System Clock (MCLK) will be effected when C-SPY has control of the device.** Special precautions are taken to minimize the effect upon the Watchdog Timer. The CPU core registers are preserved. All other clock sources (SMCLK, ACLK) and peripherals continue to operate normally during emulation. In other words, **the Flash Emulation Tool is a partially intrusive tool.**

Devices which support Clock Control (EMULATOR->ADVANCED->GENERAL CLOCK CONTROL) can further minimize these effects by selecting to stop the clock(s) during debugging.

See the FAQ, Debugging #22).

- 18) **There is a time after C-SPY performs a reset of the device** (when the C-SPY session is first started, when the Flash is reprogrammed (via INITNEW DEVICE), when JTAG is resynchronized (RESYNCHRONIZE JTAG)) and before C-SPY has regained control of the device **that the device will execute normally.** This behavior may have side effects. Once C-SPY has regained control of the device, it will perform a reset of the device and retain control.
- 19) When programming the Flash, **do not set a breakpoint on the instruction immediately following the write to Flash operation.** A simple work-around to this limitation is to follow the write to Flash operation with a NOP, and set a breakpoint on the instruction following the NOP. See the FAQ, Debugging #21).
- 20) The **Dump Memory length specifier is restricted to four hexadecimal digits (0-ffff).** This limits the number of bytes that can be written from 0 to 65535. Consequently, it is not possible to write memory from 0 to 0xffff inclusive as this would require a length specifier of 65536 (or 10000h).
- 21) Multiple internal machine cycles are required to clear and program the Flash memory. **When single stepping over instructions that manipulate the Flash,** control is given back to C-SPY before these operations are complete. Consequently, **C-SPY will update its memory window with erroneous information.** A work around to this behavior is to follow the Flash access instruction with a NOP, and then step past the NOP before reviewing the effects of the Flash access instruction. See the FAQ, Debugging #19).
- 22) **Bits that are cleared when read during normal program execution** (i.e., Interrupt Flags) **will be cleared when read while being debugged** (i.e., memory dump, peripheral registers).  
  
Within MSP430F43x/44x devices, bits do not behave this way (i.e., the bits are not cleared by C-SPY read operations).
- 23) **C-SPY cannot be used to debug programs that execute in the RAM of F12x and F41x devices.** A work around to this limitation is to debug programs in Flash.
- 24) **While single stepping with active and enabled interrupts, it can appear that only the interrupt service routine (ISR) is active** (i.e., the non-ISR code never appears to execute, and the single step operation always stops on the first line of the ISR). However, this

behavior is correct because the device will always process an active and enabled interrupt before processing non-ISR (i.e., mainline) code. A work-around for this behavior is, while within the ISR, to disable the GIE bit *on the stack* so that interrupts will be disabled after exiting the ISR. This will permit the non-ISR code to be debugged (but without interrupts). Interrupts can later be re-enabled by setting GIE in the status register in the Register window.

On devices with Clock Control, it may be possible to suspend a clock between single steps and delay an interrupt request.

- 25) **The base** (decimal, hexadecimal, etc.) **property of Watch Window variables is not preserved between C-SPY sessions**; the base reverts to Default Format.
- 26) On devices equipped with a Data Transfer Controller (DTC), **the completion of a data transfer cycle will preempt a single step of a low power mode instruction**. The device will advance beyond the low power mode instruction only after an interrupt is processed. Until an interrupt is processed, it will appear that the single step has no effect. A work around to this situation is to set a breakpoint on the instruction following the low power mode instruction, and then execute (GO) to this breakpoint.
- 27) **The transfer of data by the Data Transfer Controller (DTC) may not stop precisely when the DTC is stopped in response to a single step or a breakpoint**. When the DTC is enabled and a single step is performed, one or more bytes of data can be transferred. When the DTC is enabled and configured for two-block transfer mode, the DTC may not stop precisely on a block boundary when stopped in response to a single step or a breakpoint.
- 28) The C-SPY **Register window now supports an instruction cycle length counter**. The cycle counter is only active while single stepping. The count is reset when the device is reset or the device is run (GO). The count can be edited (normally set to zero) at any time.
- 29) **It's possible to use C-SPY to get control of a running device whose state is unknown**. Simply use C-SPY to program a dummy device, and then start the application with RELEASE JTAG ON GO selected. Remove the JTAG connector from the dummy device and connect to the unknown device. Select "DEBUG->BREAK" (or the "stop" hand) to stop the unknown device. The state of the device can then be interrogated.
- 30) RESET'ing a program temporarily requires a breakpoint if PROJECT->OPTIONS->DEBUGGER->SETUP->RUN TO is enabled. If N or more breakpoints are set, RESET will set a virtual breakpoint and will run to the RUN TO function. Consequently, **it may require a significant amount of time before the program "resets"** (i.e., stops at the RUN TO function). During this time the C-SPY will indicate that the program is running, and C-SPY windows may be blank (or may not be correctly updated).
- 31) RUN TO CURSOR temporarily requires a breakpoint. If N breakpoints are set and virtual breakpoints are disabled, **RUN TO CURSOR will**

- incorrectly use a virtual breakpoint.** This results in very slow program execution.
- 32) **The simulator is a CPU core simulator;** peripherals are not simulated, and interrupts are statistical events.
  - 33) On devices without data breakpoint capabilities, it's possible to associate with an instruction breakpoint an (arbitrarily complex) expression that C-SPY evaluates when the breakpoint is hit. **This mechanism can be used to synthesize a data breakpoint.** Refer to the C-SPY documentation for a description of this complex breakpoint mechanism.
  - 34) **The ROM-Monitor** referenced by the C-SPY documentation applies only to older MSP430Exxx (EPROM) based devices; it **can be ignored** when using the FET and the FLASH-based MSP430F device.
  - 35) **Special Function Registers (SFRs)** – or the peripheral registers – **are now displayed in VIEW->REGISTER;** there is no longer an SFR Window.
  - 36) **The putchar()/getchar() breakpoints are set only if these functions are present** (and the mechanism is enabled). Note that putchar()/getchar() could be indirectly referenced by a library function.
  - 37) **The Flash program/download progress bar does not update gradually.** This behavior is to be expected. The progress bar updates whenever a “chunk” of memory is written to Flash. The development tools attempt to minimize the number of program chunks in order to maximize programming efficiency. Consequently, it's possible for, say, a 60K byte program to be reduced to a single chunk and the progress bar will not be updated until the entire write operation is complete.

# Hardware

---



---



---

This appendix contains information relating to the FET hardware, including schematics and PCB pictorials.

<b>Topic</b>	<b>Page</b>
Figure B-1. MSP-FET430X110, Schematic	B-2
Figure B-2. MSP-FET430X110, PCB Pictorials	B-3
Figure B-3. MSP-FET430IF FET Interface Module, Schematic	B-4
Figure B-4. MSP-FET430IF FET Interface Module, PCB Pictorial	B-5
Figure B-5. MSP-TS430DW28 Target Socket Module, Schematic	B-6
Figure B-6. MSP-TS430DW28 Target Socket Module, PCB Pictorials	B-7
Figure B-7. MSP-TS430DL48 Target Socket Module Schematic	B-7
Figure B-8. MSP-TS430DL48 Target Socket Module, PCB	B-9
Figure B-9. MSP-TS430PM64 Target Socket Module, Schematic, Rev. 1.1	B-10
Figure B-10. MSP-TS430PM64 Target Socket Module, PCB Pictorials, Rev. 1.1	B-11
Figure B-11. MSP-TSPN80 Target Socket Module, Schematic	B-12
Figure B-12. MSP-TSPN80 Target Socket Module, PCB Pictorials	B-13
Figure B-13. MSP-TSPZ100 Target Socket Module, Schematic	B-14
Figure B-14. MSP-TSPZ100 Target Socket Module, PCB Pictorials	B-15
Figure B-15. MSP-FET430UIF USB Interface Schematics	B-16

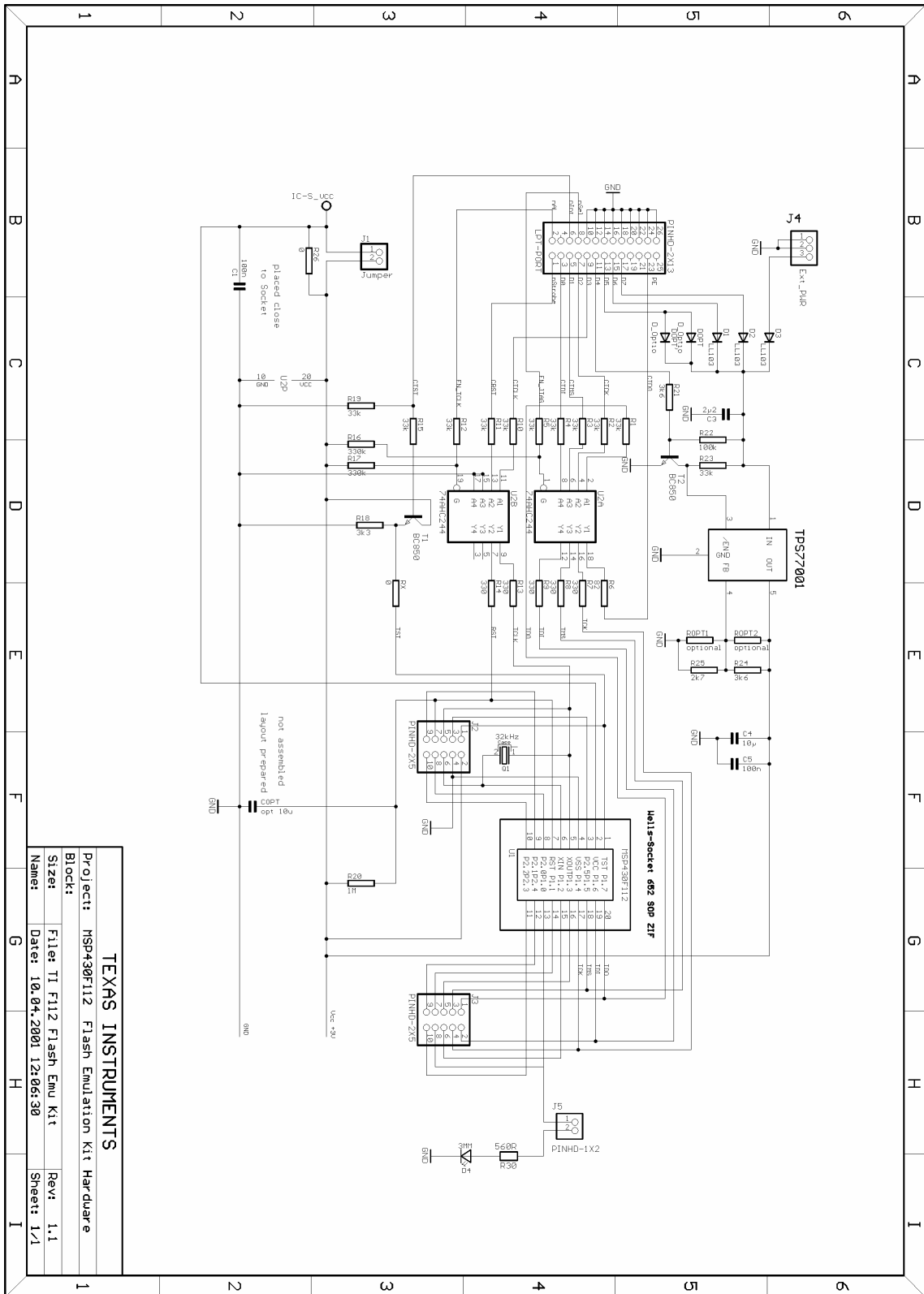
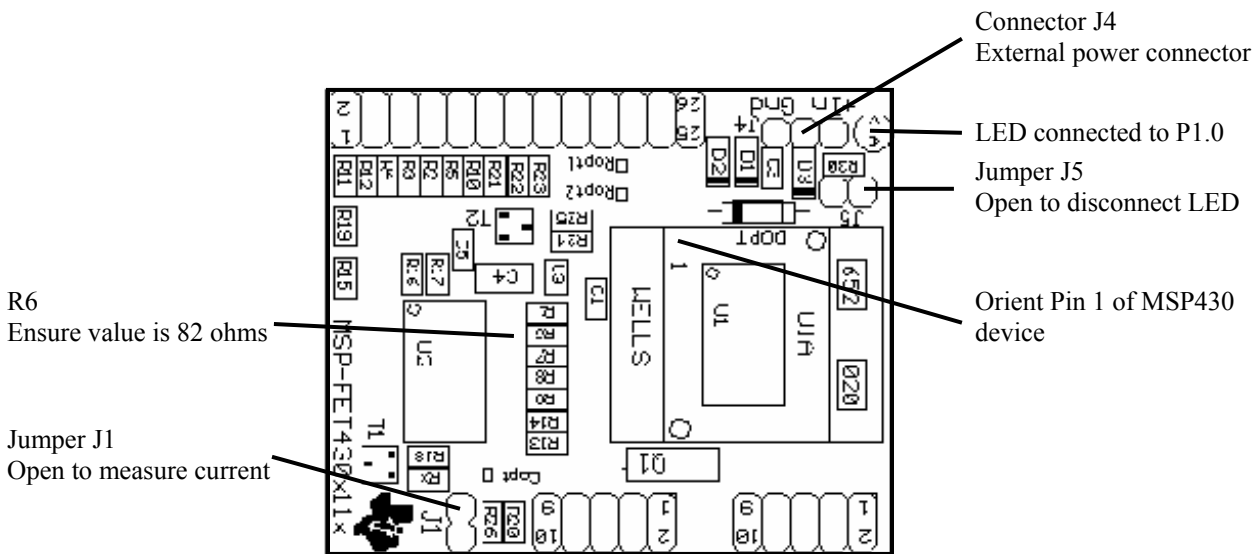
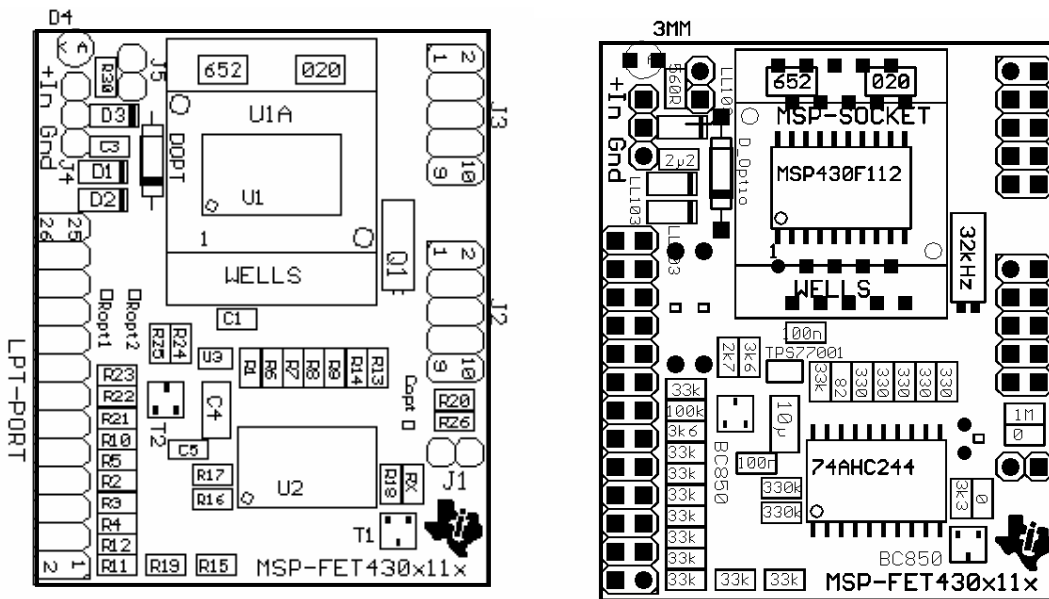

Figure B-1. MSP-FET430X110, Schematic



J2				
P2.1	RST	XOUT	P2.5	TST
P2.2	P2.0	XIN	Vss	Vcc

J3				
P2.4	P1.1	P1.3	P1.5	P1.7
P2.3	P1.0	P1.2	P1.4	P1.6

Figure B-2. MSP-FET430X110, PCB Pictorials

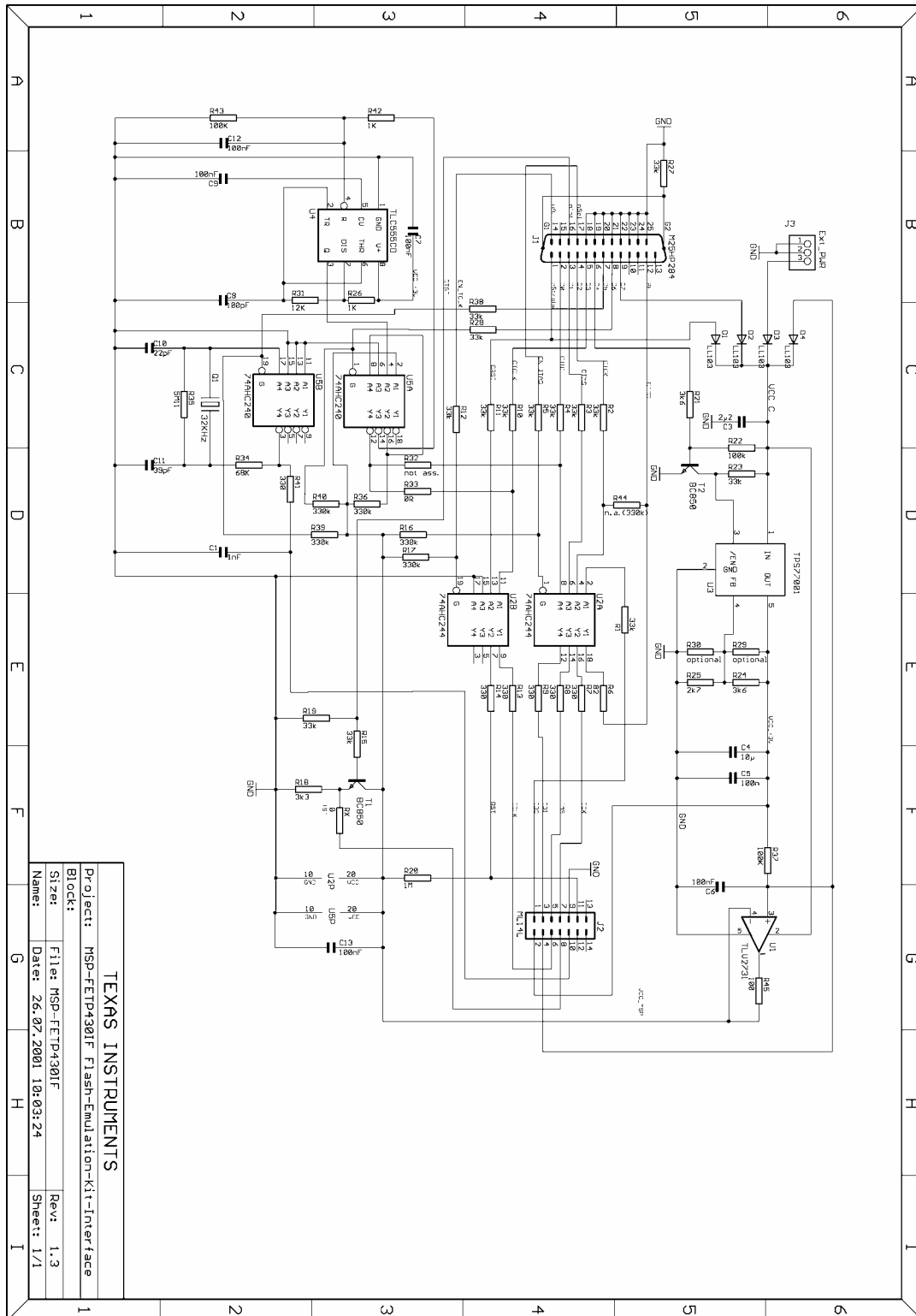

Figure B-3. MSP-FET430IF FET Interface Module, Schematic

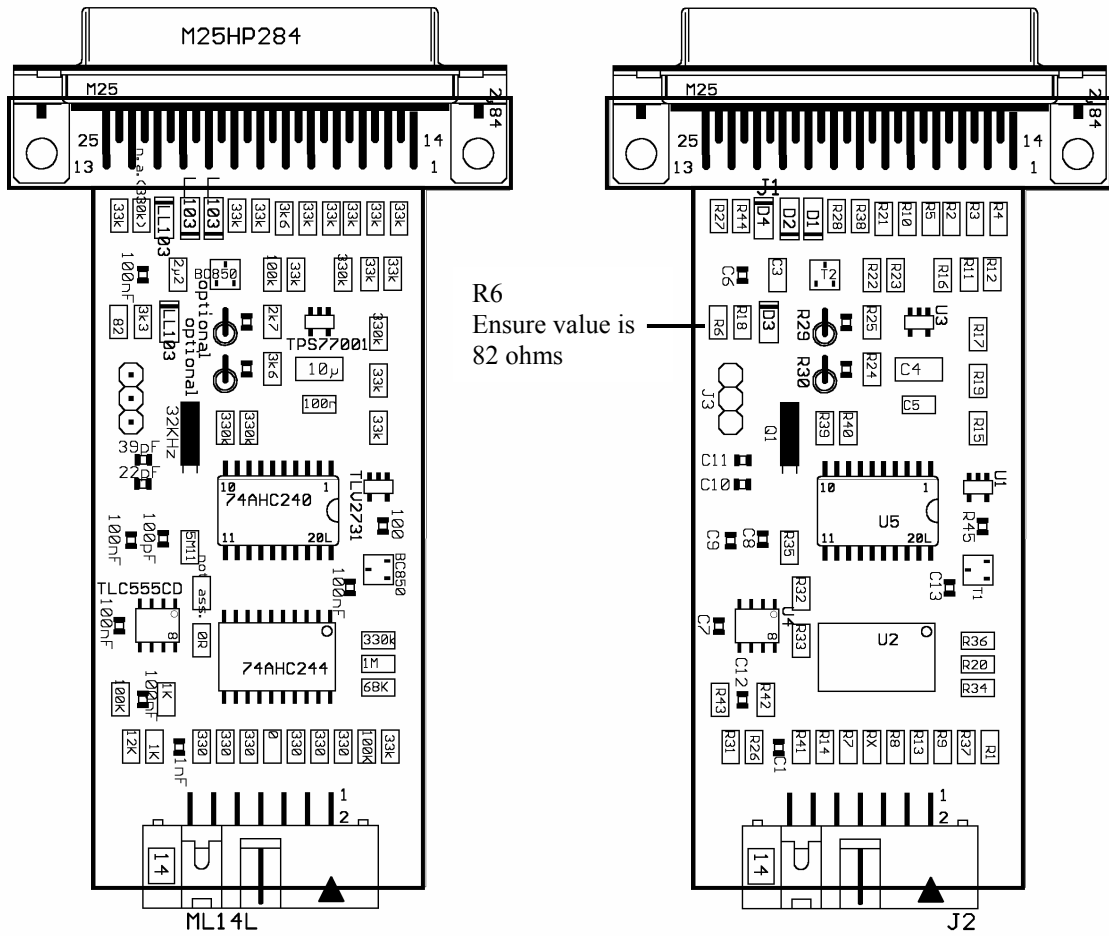

Figure B-4. MSP-FET430IF FET Interface Module, PCB Pictorial



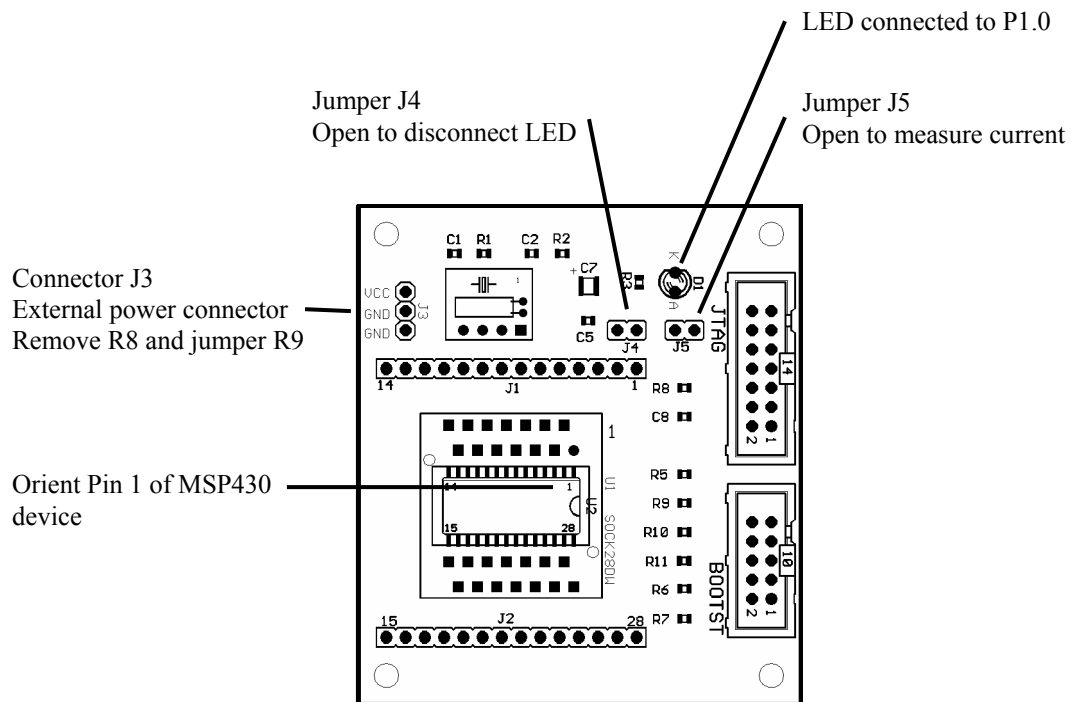
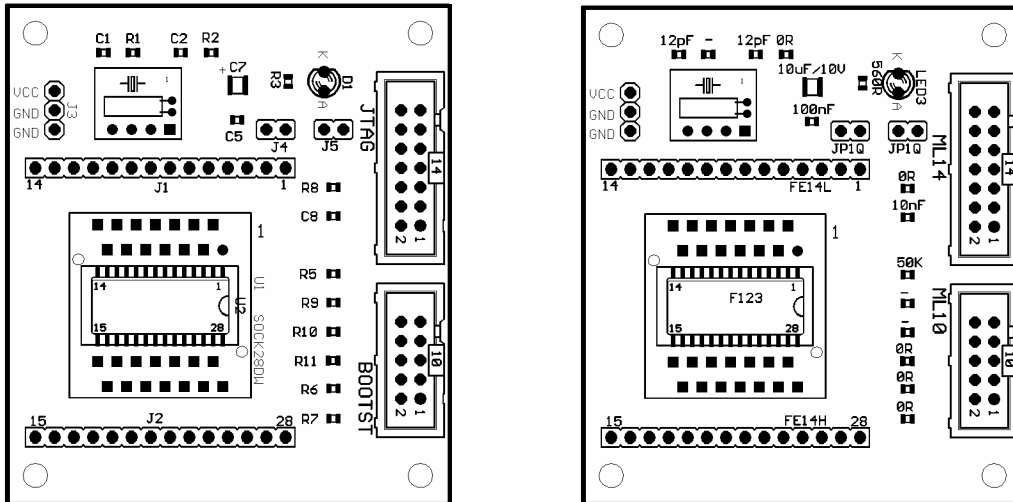

Figure B-6. MSP-TS430DW28 Target Socket Module, PCB Pictorials

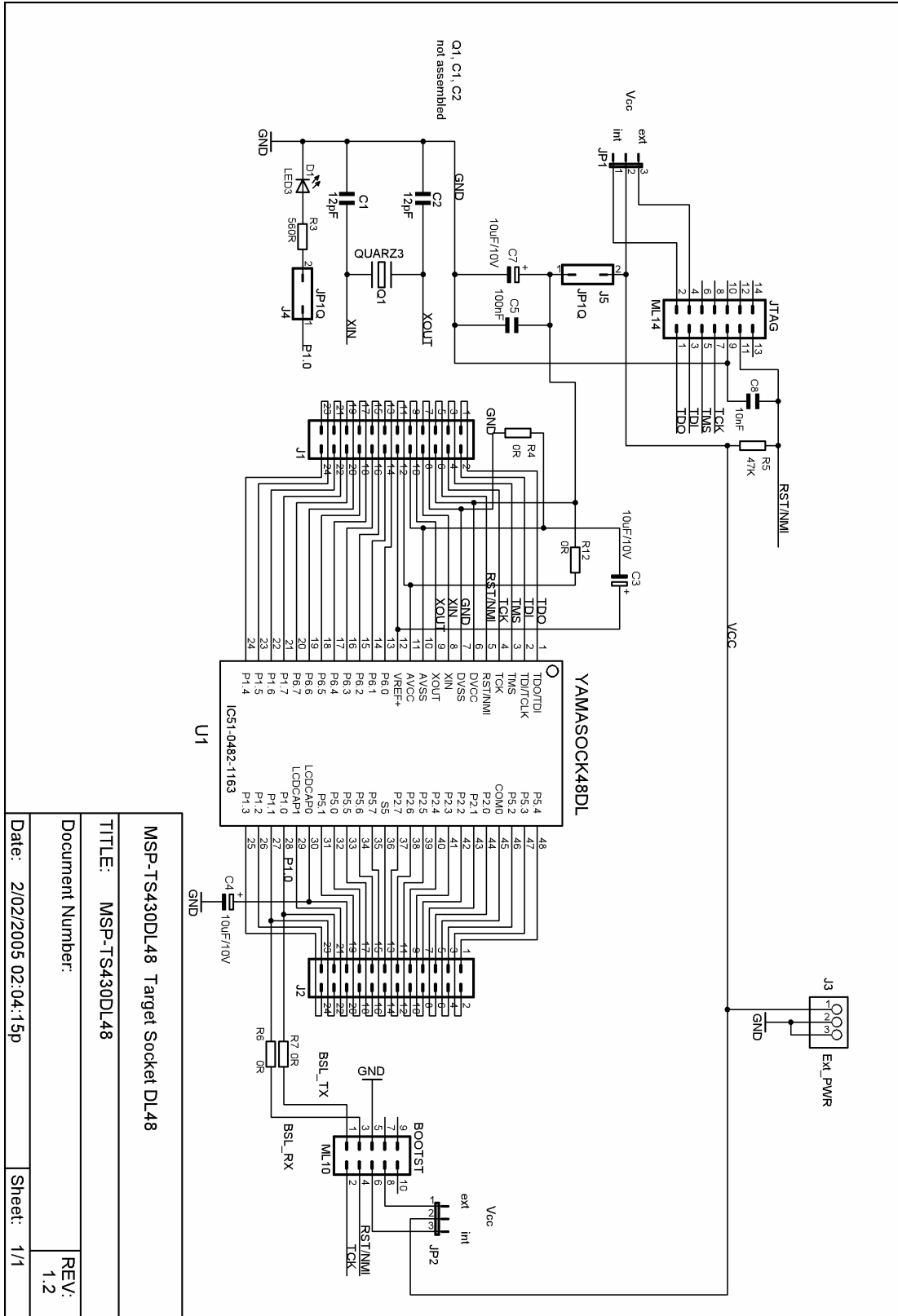

Figure B-7. MSP-TS430DL48 Target Socket Module Schematic

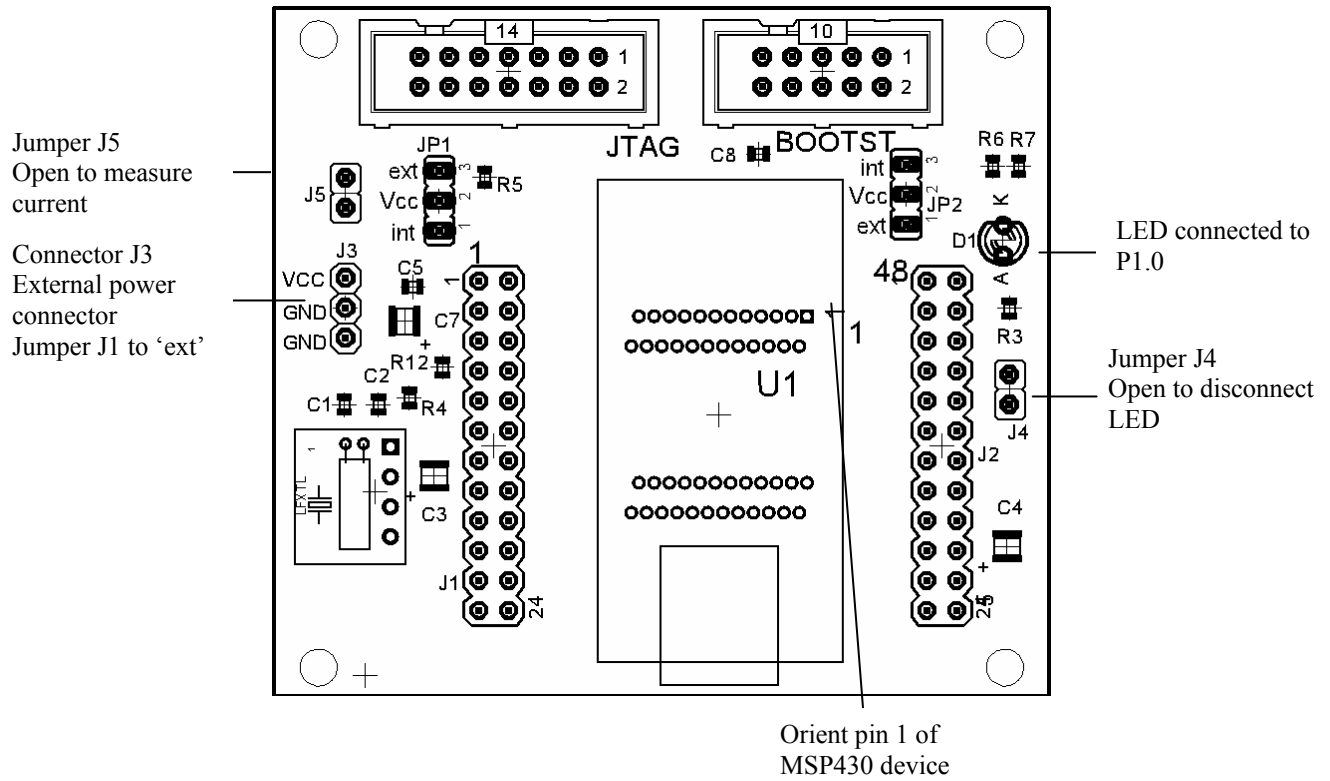

Figure B-8. MSP-TS430DL48 Target Socket Module, PCB



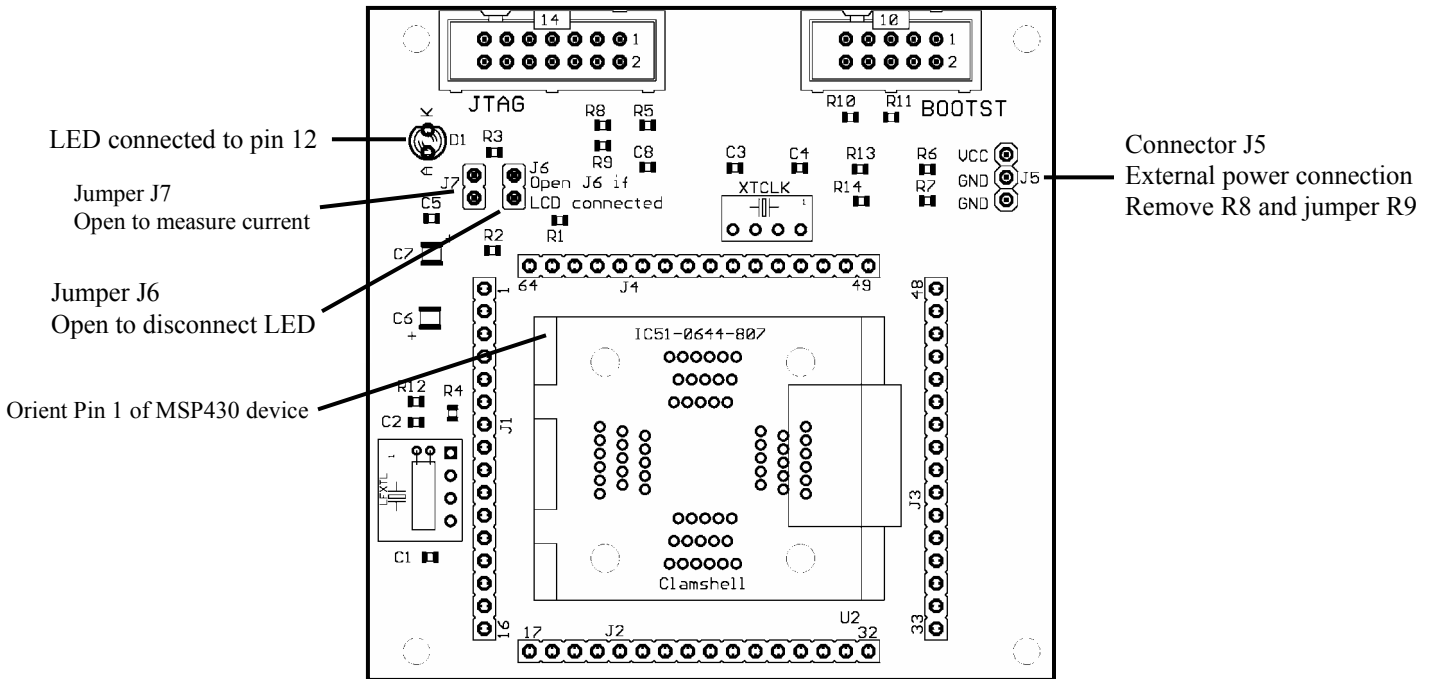
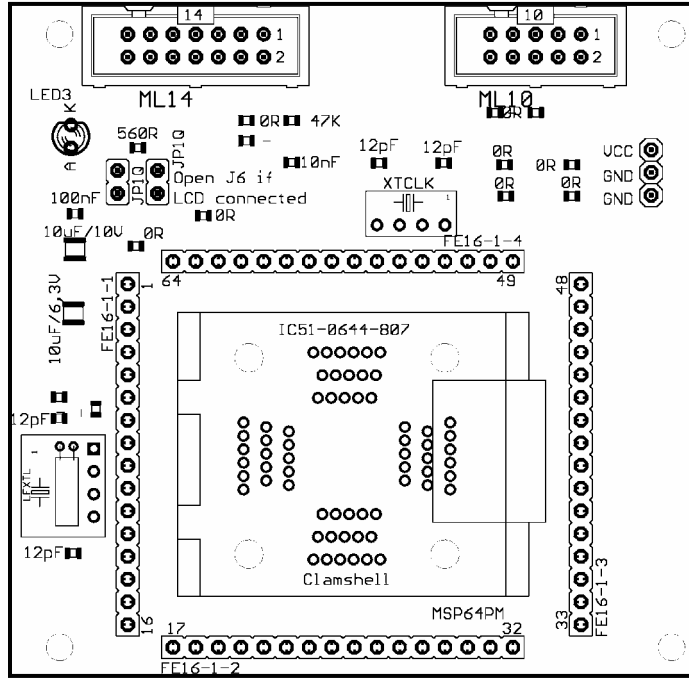

Figure B-10. MSP-TS430PM64 Target Socket <odule, PCB Pictorials, Rev. 1.1



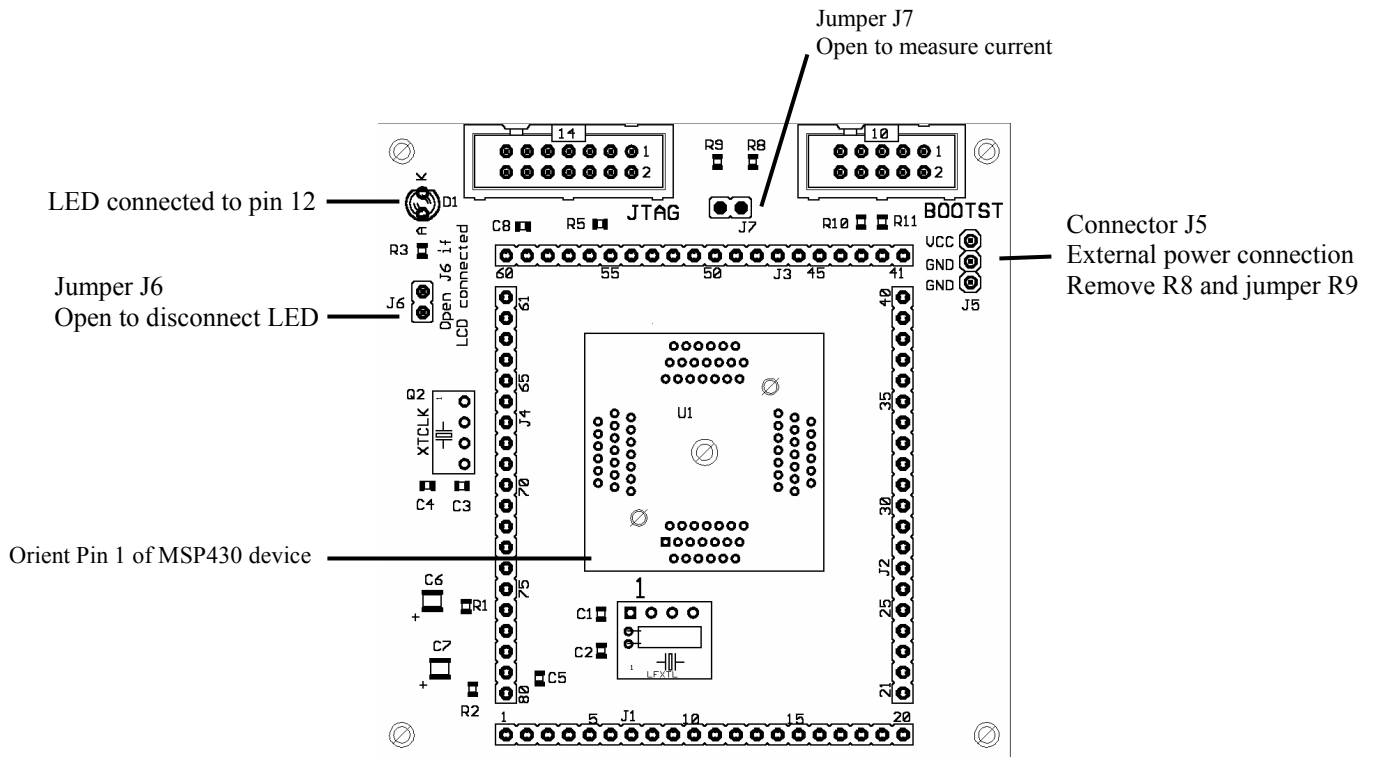
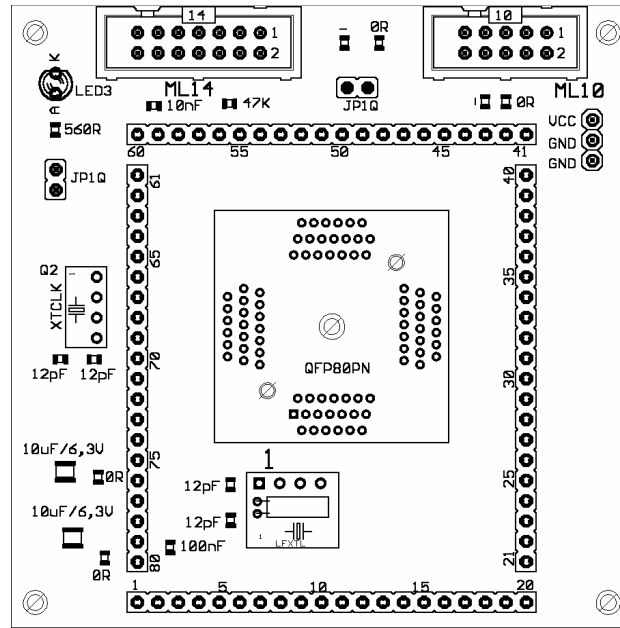
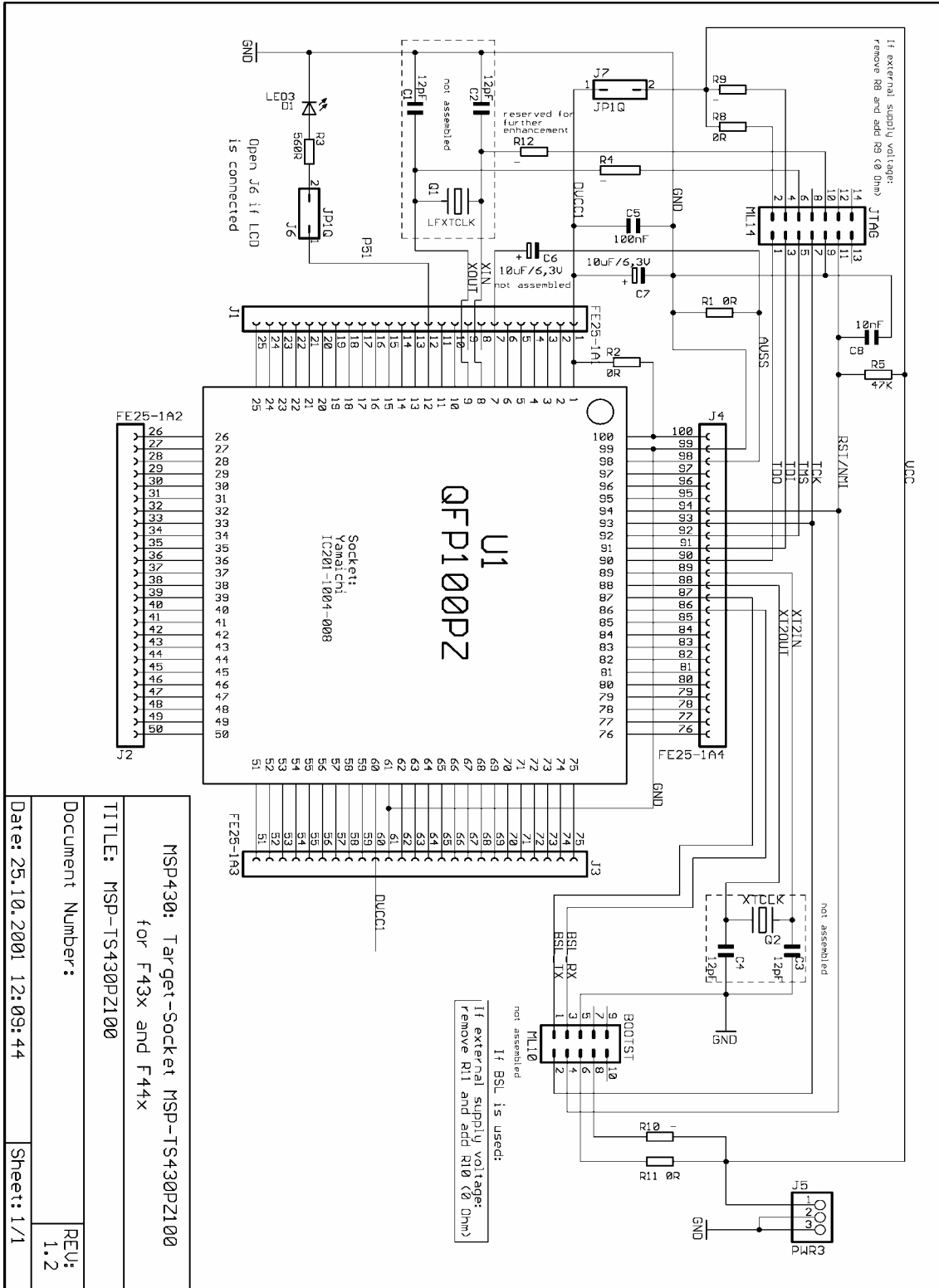

Figure B-12. MSP-TSPN80 Target Socket Module, PCB Pictorials



MSP430: Target-Socket MSP-TS430PZ100 for F43X and F44X	
TITLE: MSP-TS430PZ100	
Document Number:	REV: 1.2
Date: 25.10.2001 12:09:44	Sheet: 1/1

**Note:** Connections between the JTAG header and pins XOUT and XIN are no longer required and should not be made.

Figure B-13. MSP-TSPZ100 Target Socket Module, Schematic

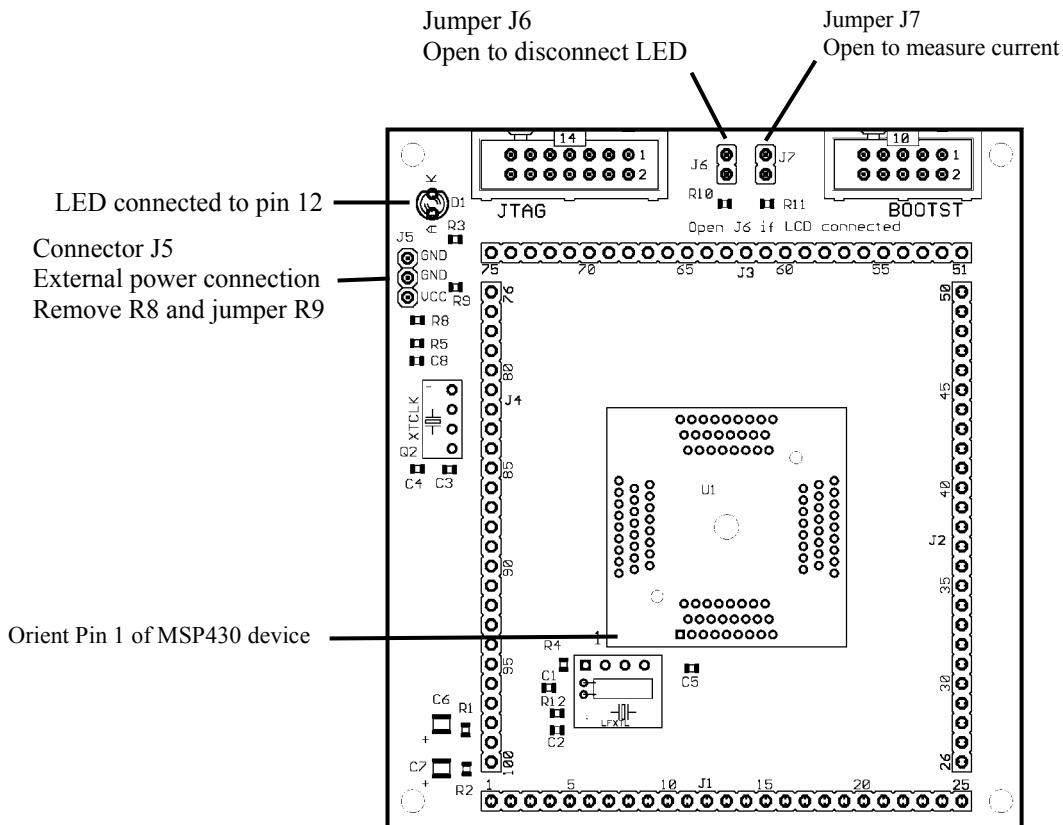
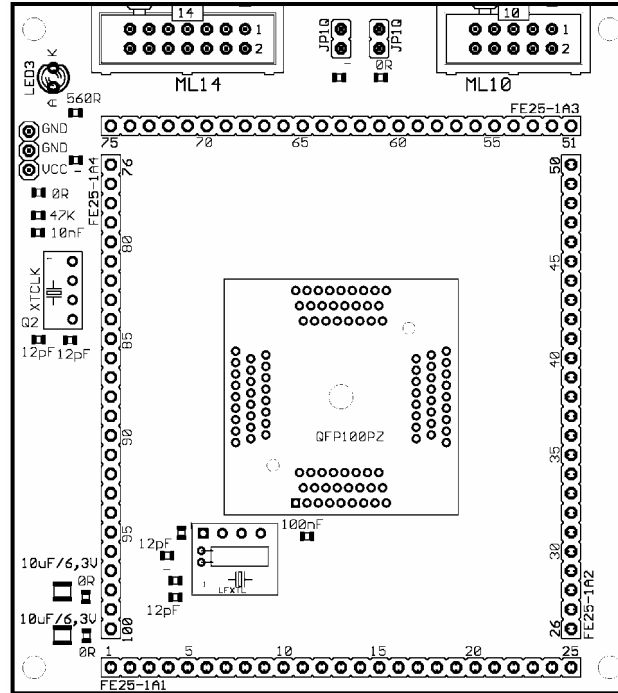

Figure B-14. MSP-TSPZ100 Target Socket Module, PCB Pictorials

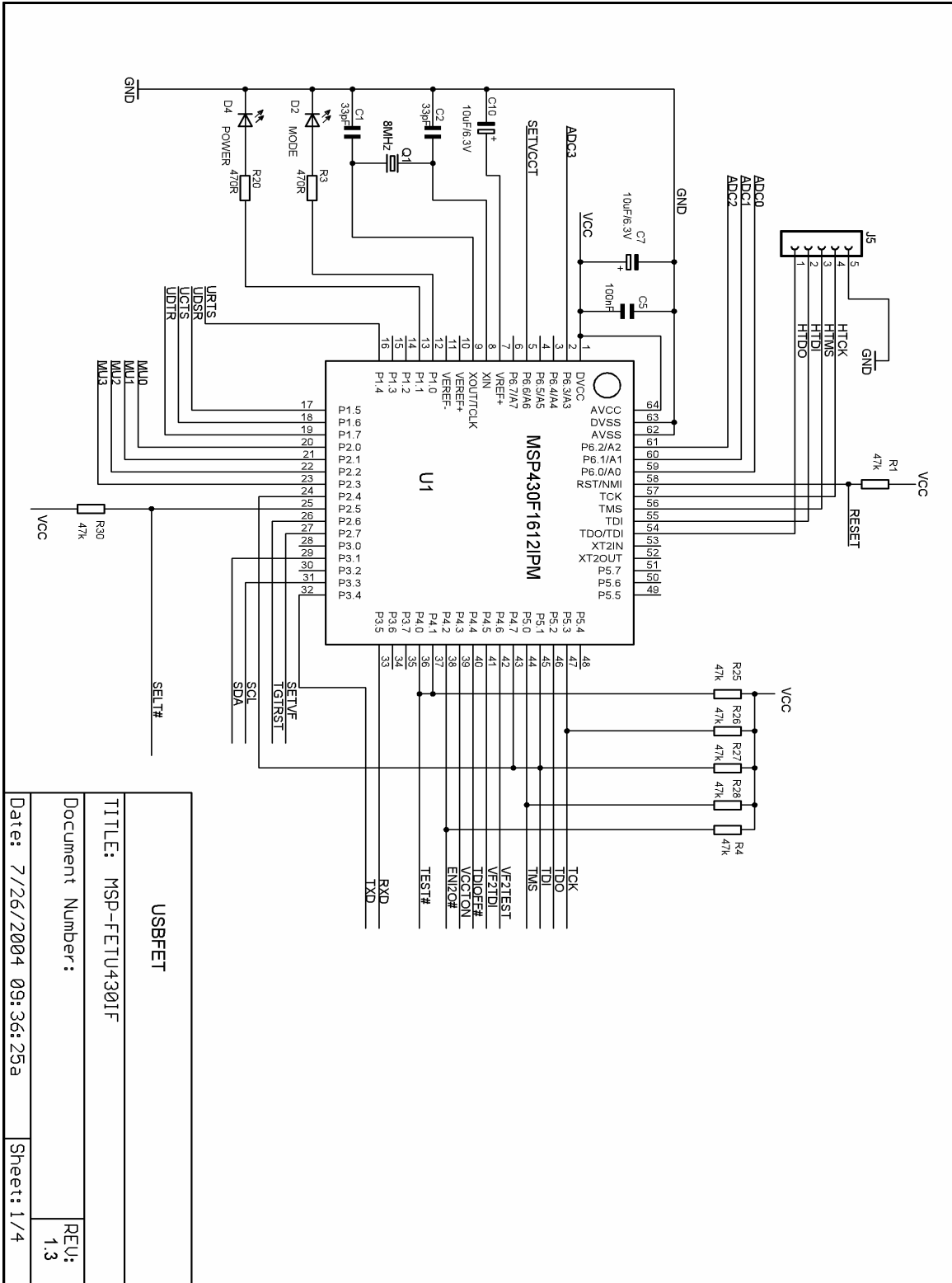
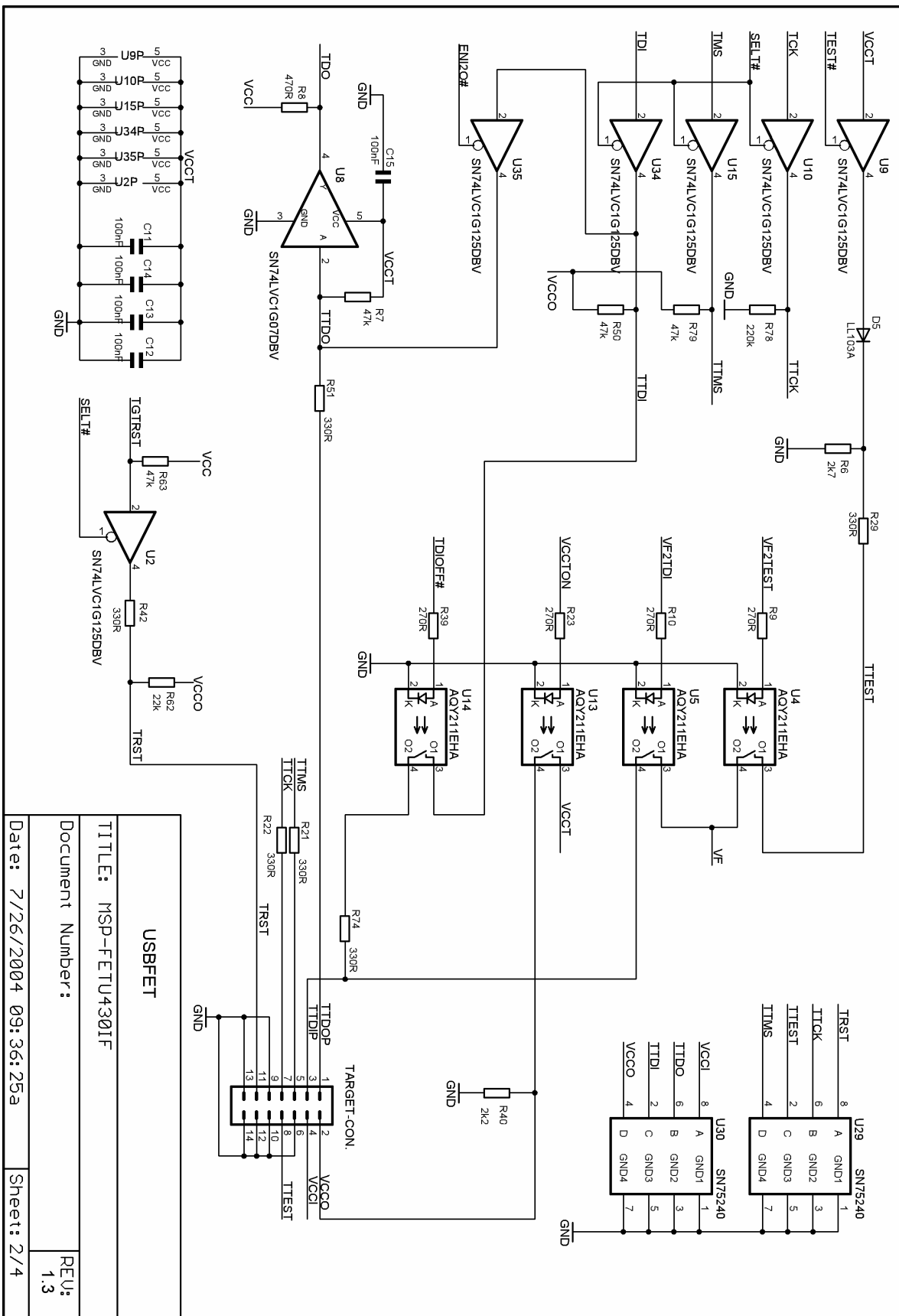

Figure B-15. MSP-FET430UIF USB Interface Schematics



USB FET

TITLE: MSP-FETU4301F

Document Number:

Date: 7/26/2004 09:36:25a

Sheet: 2/4

REU:  
1.3

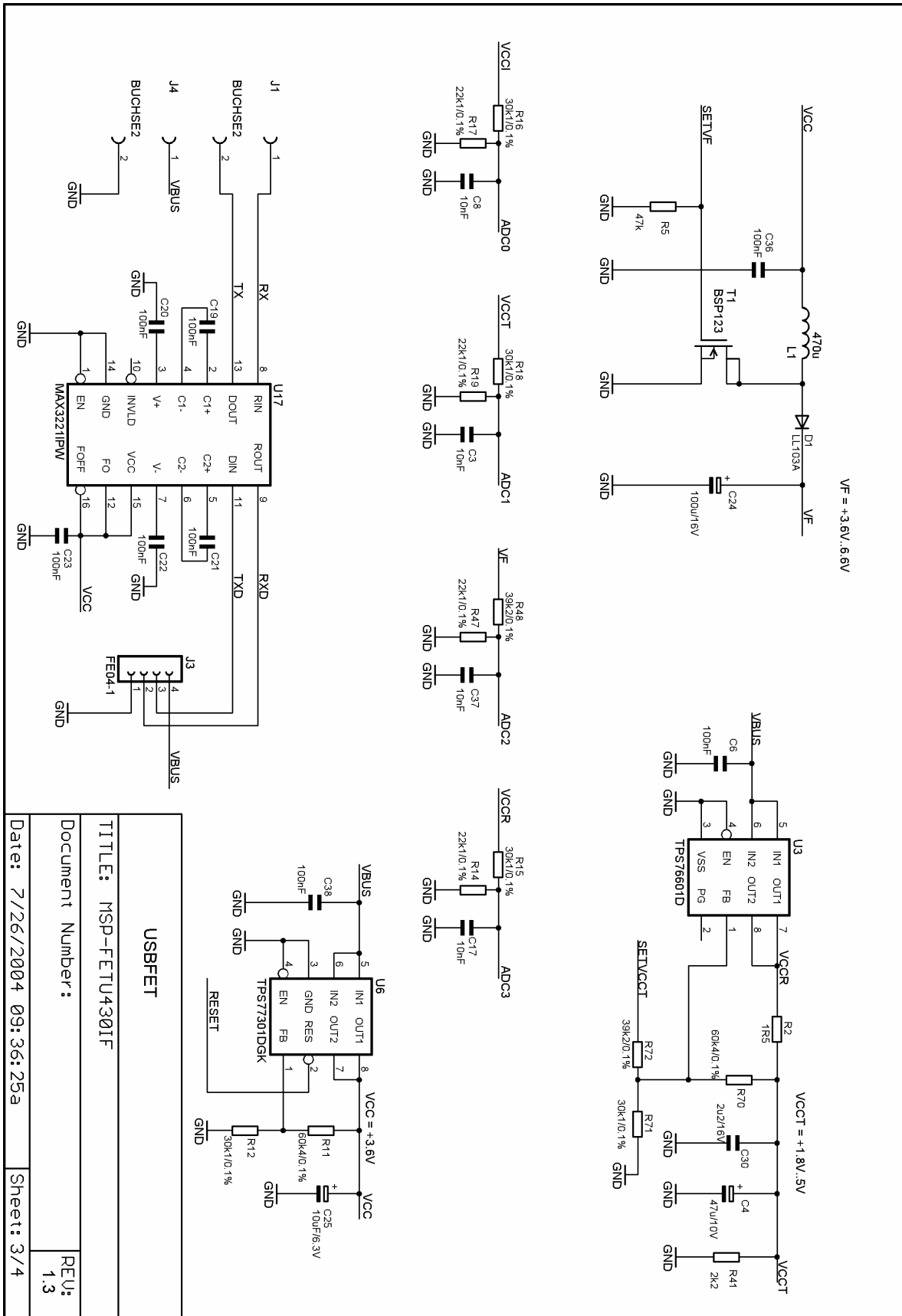

TITLE: MSP-FETU4301F	
Document Number:	
Date: 7/26/2004 09:36:25a	Sheet: 3/4
REU:	1.3





# FET Specific Menus

---



---



---

This appendix describes the C-SPY menus that are specific to the FET.

<b>Topic</b>	<b>Page</b>
C.1 EMULATOR	C-2
C.1.1 EMULATOR->RELEASE JTAG ON GO	C-2
C.1.2 EMULATOR->RESYNCHRONIZE JTAG	C-2
C.1.3 EMULATOR->INIT NEW DEVICE	C-2
C.1.4 EMULATOR->SHOW USED BREAKPOINTS	C-2
C.1.5 EMULATOR->ADVANCED->GENERAL CLOCK CONTROL	C-2
C.1.6 EMULATOR->ADVANCED->EMULATION MODE	C-2
C.1.7 EMULATOR->ADVANCED->MEMORY DUMP	C-3
C.1.8 EMULATOR->ADVANCED->BREAKPOINT COMBINER	C-3
C.1.9 EMULATOR->STATE STORAGE	C-3
C.1.10 EMULATOR->STATE STORAGE WINDOW	C-3
C.1.11 EMULATOR->SEQUENCER	C-3
C.1.12 EMULATOR->"POWER ON" RESET	C-3
C.1.13 EMULATOR->SECURE	C-3
C.1.14 EMULATOR->GIE on/off	C-3
C.1.15 EMULATOR->LEAVE TARGET RUNNING	C-4
C.1.16 EMULATOR->FORCE SINGLE STEPPING	C-4
C.1.17 EMULATOR->SET VCC	C-4

## **C.1 EMULATOR**

The current device type is displayed.

### **C.1.1 EMULATOR->RELEASE JTAG ON GO**

C-SPY uses the device JTAG signals to debug the device. On some MSP430 devices, these JTAG signals are shared with the device port pins. Normally, C-SPY maintains the pins in JTAG mode so that the device can be debugged. During this time the port functionality of the shared pins is not available.

However, when RELEASE JTAG ON GO is selected, the JTAG drivers are set to tri-state and the device is released from JTAG control (TEST pin is set to GND) when GO is activated. Any active on-chip breakpoints are retained and the shared JTAG port pins revert to their port functions.

At this time, C-SPY has no access to the device and cannot determine if an active breakpoint (if any) has been reached. C-SPY must be manually commanded to stop the device, at which time the state of the device will be determined (i.e., Was a breakpoint reached?).

See the FAQ, Debugging #10).

### **C.1.2 EMULATOR->RESYNCHRONIZE JTAG**

Regain control of the device.

It is not possible to RESYNCHRONIZE JTAG while the device is operating.

### **C.1.3 EMULATOR->INIT NEW DEVICE**

Initialize the device according to the settings in the DOWNLOAD OPTIONS. Basically, the current program file is downloaded to the device memory. The device is then reset. This option can be used to program multiple devices with the same program from within the same C-SPY session.

It is not possible to select INIT NEW DEVICE while the device is operating.

### **C.1.4 EMULATOR->SHOW USED BREAKPOINTS**

List all used hardware and virtual breakpoints, as well as all currently defined EEM breakpoints.

### **C.1.5 EMULATOR->ADVANCED->GENERAL CLOCK CONTROL**

Disable the specified system clock while C-SPY has control of the device (following a STOP or breakpoint). All system clocks are enabled following a GO or a single step (STEP/STEP INTO). See the FAQ, Debugging #17).

### **C.1.6 EMULATOR->ADVANCED->EMULATION MODE**

Specify the device to be emulated. The device must be reset (or reinitialized through INIT NEW DEVICE) following a change to the emulation mode.

See Appendix D.

**C.1.7 EMULATOR->ADVANCED->MEMORY DUMP**

Write the specified device memory contents to a specified file. A conventional dialog is displayed that permits the user to specify a file name, a memory starting address, and a length. The addressed memory is then written in a text format to the named file. Options permit the user to select word or byte text format, and address information and register contents can also be appended to the file.

**C.1.8 EMULATOR->ADVANCED->BREAKPOINT COMBINER**

Open the Breakpoint Combiner dialog box. The Breakpoint Combiner dialog box permits one to specify breakpoint dependencies. A breakpoint will be triggered when the breakpoints are encountered in the specified order.

**C.1.9 EMULATOR->STATE STORAGE**

Open the State Storage dialog box. The State Storage dialog box permits one to use the state storage module. The state storage module is present only in those devices that contain the EEM.

See the IAR C-SPY FET Debugger section in the MSP430 IAR Embedded Workbench IDE user's guide.

**C.1.10 EMULATOR->STATE STORAGE WINDOW**

Open the State Storage window, and display the stored state information as configured by the State Storage dialog.

See the IAR C-SPY FET Debugger section in the MSP430 IAR Embedded Workbench IDE user's guide.

**C.1.11 EMULATOR->SEQUENCER**

Open the Sequencer dialog box. The Sequencer dialog box permits one to configure the sequencer state machine.

See the IAR C-SPY FET Debugger section in the MSP430 IAR Embedded Workbench IDE user's guide.

**C.1.12 EMULATOR->"POWER ON" RESET**

Cycle power to the device to effect a reset.

**C.1.13 EMULATOR->SECURE**

Programs the code security fuse. No further access via JTAG is possible.

**C.1.14 EMULATOR->GIE on/off**

Enables or disables all interrupts. Needs to be restored manually before GO.

### **C.1.15 EMULATOR->LEAVE TARGET RUNNING**

If C-SPY is closed, the target keeps running the user program.

### **C.1.16 EMULATOR->FORCE SINGLE STEPPING**

On GO the program is executed by single steps. Only in this mode the cycle counter works correctly.

### **C.1.17 EMULATOR->SET VCC**

On the USB FET the target supply voltage can be adjusted between 1.8 V and 5 V. This voltage is available on pin 2 of the 14-pin target connector to supply the target from the USB FET. If the target is supplied externally, the external supply voltage should be connected to pin 4 of the target connector, so the USB FET can set the level of the output signals accordingly.

**Note: Availability of EMULATOR->ADVANCED menus**

Not all **EMULATOR->ADVANCED** menus are supported by all MSP430 devices. These menus will be grayed-out.

# 80-pin MSP430F44x and MSP430F43x Device Emulation

---

---

---

80-pin MSP430F44x and MSP430F43x devices can be emulated by the 100-pin MSP430F449 device. Table D-1. F4xx/80-Pin Signal Mapping Table D-1 lists where the pin signals of an 80-pin device appear on the pins of an MSP-TS430PZ100 Target Socket module. Note: The MSP-TS430PZ100 must be modified as indicated. See Appendix C.1.6 to enable the emulation mode.

Topic	Page
Table D-1. F4xx/80-Pin Signal Mapping	D-2

Table D-1. F4xx/80-Pin Signal Mapping

F4xx/80-Pin Signal	F4xx/80 Pin Number	MSP430-TS430PZ100 Pin Number	Connection Required Between Indicated Pins of MSP430-TS430PZ100 Socket
DVcc1	1	1	
P6.3/A3	2	2	
P6.4/A4	3	3	
P6.5/A5	4	4	
P6.6/A6	5	5	
P6.7/A7	6	6	
VREF+	7	7	
XIN	8	8	
XOUT	9	9	
VeREF+	10	10	
VREF-/VeREF-	11	11	
P5.1/S0	12	12	
P5.0/S1	13	13	
P4.7/S2	14	14	14-46
P4.6/S3	15	15	15-47
P4.5/S4	16	16	16-48
P4.4/S5	17	17	17-49
P4.3/S6	18	16	18-50
P4.2/S7	19	19	19-51
P4.1/S8	20	20	20-62
P4.0/S9	21	21	21-63
S10	22	22	
S11	23	23	
S12	24	24	
S13	25	25	
S14	26	26	
S15	27	27	
S16	28	28	
S17	29	29	
P2.7/ADC12CLK/S18	30	30	
P2.6/CAOUT/S19	31	31	
S20	32	32	
S21	33	33	
S22	34	34	
S23	35	35	
P3.7/S24	36	36	36-64
P3.6/S25	37	37	37-65
P3.5/S24	38	38	38-66
P3.4/S27	39	39	39-67
P3.3/UCLK0/S28	40	40	40-68
P3.2/SOMI0/S29	41	41	41-69
P3.1/SIMO0/S30	42	42	42-70
P3.0/STE0/S31	43	43	43-71
COM0	44	52†	
P5.2/COM1	45	53	
P5.3/COM2	46	54	
P5.4/COM3	47	55	
R03	48	56	
P5.5/R13	49	57	
P5.6/R23	50	58	

P5.7/R33	51	59	
DVcc2	52	60	
DVss2	53	61	
P2.5/URXD0	54	74†	
P2.4/UTXD0	55	75	
P2.3.TB2	56	76	
P2.2/TB1	57	77	
P2.1/TB0	58	78	
P2.0/TA2	59	79	
P1.7/CA1	60	80	
P1.6/CA0	61	81	
P1.5/TACLK/AC LK	62	82	
P1.4/TBCLK/SM CLK	63	83	
P1.3/TBOUTH/S VSOUT	64	84	
P1.2/TA1	65	85	
P1.1/TA0/MCLK	66	86	
P1.0/TA0	67	87	
XT2OUT	68	88	
XT2IN	69	89	
TDO/TDI	70	90	
TDI	71	91	
TMS	72	92	
TCK	73	93	
RST/NMI	74	94	
P6.0/A0	75	95	
P6.1/A1	76	96	
P6.2/A2	77	97	
Avss	78	98	
DVss1	79	99	
Avcc	80	100	

† Note discontinuity of pin numbering sequence

# Texas Instruments to IAR 2.x/3.x Assembler Migration

---



---



---

Texas Instruments made a suite of development tools for the MSP430, including a comprehensive assembler and device simulator. The source of the Texas Instruments assembler and the source of the Kickstart assembler are not 100% compatible; the instruction mnemonics are identical, while the assembler directives are somewhat different. The following section documents the differences between the Texas Instruments assembler directives and the Kickstart 2.x/3.x assembler directives.

<b>Topic</b>	<b>Page</b>
<b>E.1 Segment Control</b>	<b>E-2</b>
<b>E.2 Translating Asm430 Assembler Directives to A430 Directives</b>	<b>E-2</b>
<b>E.2.1 Introduction</b>	<b>E-2</b>
<b>E.2.2 Character Strings</b>	<b>E-2</b>
<b>E.2.3 Section Control Directives</b>	<b>E-3</b>
<b>E.2.4 Constant Initialization Directives</b>	<b>E-4</b>
<b>E.2.5 Listing Control Directives</b>	<b>E-4</b>
<b>E.2.6 File Reference Directives</b>	<b>E-5</b>
<b>E.2.7 Conditional-Assembly Directives</b>	<b>E-5</b>
<b>E.2.8 Symbol Control Directives</b>	<b>E-6</b>
<b>E.2.9 Macro Directives</b>	<b>E-7</b>
<b>E.2.10 Miscellaneous Directives</b>	<b>E-7</b>
<b>E.2.11 Preprocessor Directives</b>	<b>E-8</b>
<b>E.2.12 Alphabetical Listing and Cross Reference of Asm430 Directives</b>	<b>E-8</b>
<b>E.2.13 Additional A430 Directives (IAR)</b>	<b>E-8</b>

## E.1 Segment Control

RSEG defines a Relocatable SEGment. A relocatable segment means that the code that follows the RSEG statement will be placed somewhere in the region defined for that segment (in the .xcl file). In other words, the code can be "relocated" and you don't know (or care) where it's put. In the .xcl files provided with the FET, multiple segments are defined in the same memory regions. ASEG defines an Absolute SEGment. An absolute segment means that the code that follows the ASEG statement will be placed in the order it is encountered in the region defined for the segment (in the .xcl file). In other words, the placement of the code is fixed in memory. One significant difference between the new IAR assembler and the old Texas Instruments assembler is the meaning of the ORG statement. In the old Texas Instruments assembler, ORG would set the assembler code pointer to the specified absolute address. However, the IAR assembler uses ORG to set an offset from the current RSEG. Fortunately, if you don't use RSEG explicitly, it defaults to 0 (zero) and your program will link as you expected (with your code at ORG). Be careful if you mix RSEG and ORG as ORG then becomes a relative offset. Use ASEG if you want the (absolute) behavior of the old Texas Instruments ORG statement.

## E.2 Translating Asm430 Assembler Directives to A430 Directives

### E.2.1 Introduction

The following sections describe, in general, how to convert assembler directives for Texas Instruments' Asm430 assembler (Asm430) to assembler directives for IAR's A430 assembler (A430). These sections are only intended to act as a guide for translation. For detailed descriptions of each directive, see either *the MSP430 Assembly Language Tools User's Guide*, SLAUE12, from Texas Instruments or *the MSP430 Assembler User's Guide* from IAR.

**Note: Only the assembler *directives* require conversion**

Only the assembler *directives* require conversion - not the assembler *instructions*. Both assemblers use the same instruction mnemonics, operands, operators, and special symbols such as the section program counter (\$), and the comment delimiter (;).

The A430 assembler is not case sensitive by default. These sections show the A430 directives written in uppercase to distinguish them from the Asm430 directives, which are shown in lower case.

### E.2.2 Character Strings

In addition to using different directives, each assembler uses different syntax for character strings. A430 uses C syntax for character strings: A quote is represented using the backslash character as an escape character together with quote (") and the backslash itself is represented by two

consecutive backslashes (\\). In Asm430 syntax, a quote is represented by two consecutive quotes (""). See examples below:

Character String	Asm430 Syntax (TI)	A430 Syntax (IAR)
PLAN "C"	"PLAN ""C"""	"PLAN \C\"
\\dos\\command.com	"\\dos\\command.com"	"\\dos\\command.com"
Concatenated string (i.e. Error 41)	-	"Error "41"

### E.2.3 Section Control Directives

Asm430 has three predefined sections into which various parts of a program are assembled. Uninitialized data is assembled into the .bss section, initialized data into the .data section and executable code into the .text section.

A430 also uses sections or segments, but there are no predefined segment names. Often, it is convenient to adhere to the names used by the C compiler: DATA16\_Z for uninitialized data, CONST for constant (initialized) data and CODE for executable code. The table below uses these names.

A pair of segments can be used to make initialized, modifiable data PROM-able. The ROM segment would contain the initializers and would be copied to RAM segment by a start-up routine. In this case, the segments must be exactly the same size and layout.

Description	Asm430 Directive (TI)	A430 Directive (IAR)
Reserve size bytes in the .bss (uninitialized data) section	.bss	See Note 1
Assemble into the .data (initialized data) section	.data	RSEG <i>const</i>
Assemble into a named (initialized) section	.sect	RSEG
Assemble into the .text (executable code) section	.text	RSEG <i>code</i>
Reserve space in a named (uninitialized) section	.usect	See Note 1
Alignment on byte boundary	.align	See Note 2
Alignment on word boundary	.even	EVEN

- 1) Space is reserved in an uninitialized segment by first switching to that segment, then defining the appropriate memory block, and then switching back to the original segment. For example:

```

RSEG DATA16_Z
LABEL: DS 16
RSEG CODE

```

- 2) Initialization of bit-field constants (.field) is not supported, therefore, the section counter is always byte-aligned.

Additional A430 Directives (IAR)	A430 Directive (IAR)
Switch to an absolute segment	ASEG
Switch to a relocatable segment	RSEG
Switch to a common segment	COMMON
Switch to a stack segment (high-to-low allocation)	STACK
Alignment on specified address boundary (power of two)	ALIGN
Set the location counter	ORG

## E.2.4 Constant Initialization Directives

Description	Asm430 Directive (TI)	A430 Directive (IAR)
Initialize one or more successive bytes or text strings	.byte or .string	DB
Initialize a 48-bit MSP430 floating-point constant	.double	See Note 1
Initialize a variable-length field	.field	See Note 2
Initialize a 32-bit MSP430 floating-point constant	.float	DF (See Note 3)
Reserve size bytes in the current section	.space	DS
Initialize one or more text strings	.string	DB
Initialize one or more 16-bit integers	.word	DW

- 1) The 48-bit MSP430 format is not supported
- 2) Initialization of bit-field constants (.field) is not supported. Constants must be combined into complete words using DW.

```

; Asm430 code                      ; A430 code
.field 5,3      \
.field 12,4     | ->                DW (30<<(4+3))|(12<<3)|5 ; equals 3941
.field 30,8     /

```

- 3) The 32-bit IEEE floating-point format, used by the C Compiler, is supported in the A430 assembler.

Additional A430 Directives (IAR)	A430 Directive (IAR)
Initialize one or more 32-bit integers	DL

## E.2.5 Listing Control Directives

Description	Asm430 Directive (TI)	A430 Directive (IAR)
Allow false conditional code block listing	.fclist	LSTCND-
Inhibit false conditional code block listing	.fcnolist	LSTCND+
Set the page length of the source listing	.length	PAGSIZ
Set the page width of the source listing	.width	COL
Restart the source listing	.list	LSTOUT+
Stop the source listing	.nolist	LSTOUT-
Allow macro listings and loop blocks	.mlist	LSTEXP+ (macro) LSTREP+ (loop blocks)
Inhibit macro listings and loop blocks	.mnolist	LSTEXP- (macro) LSTREP- (loop blocks)
Select output listing options	.option	See Note 1
Eject a page in the source listing	.page	PAGE
Allow expanded substitution symbol listing	.sslist	See Note 2
Inhibit expanded substitution symbol listing	.ssnolist	See Note 2
Print a title in the listing page header	.title	See Note 3

- 1) No A430 directive directly corresponds to .option. The individual listing control directives (above) or the command-line option -c (with suboptions) should be used to replace the .option directive.
- 2) There is no directive that directly corresponds to .sslist/.ssnolist.
- 3) The title in the listing page header is the source file name.

Additional A430 Directives (IAR)	A430 Directive (IAR)
Allow/inhibit listing of macro definitions	LSTMAC (+/-)
Allow/inhibit multi-line code listing	LSTCOD (+/-)
Allow/inhibit partitioning of listing into pages	LSTPAG (+/-)
Generate cross reference table	LSTXREF (+/-)

## E.2.6 File Reference Directives

Description	Asm430 Directive (TI)	A430 Directive (IAR)
Include source statements from another file	.copy or .include	#include or \$
Identify one or more symbols that are defined in the current module and used in other modules	.def	PUBLIC or EXPORT
Identify one or more global (external) symbols	.global	See Note 1
Define a macro library	.mlib	See Note 2
Identify one or more symbols that are used in the current module but defined in another module	.ref	EXTERN or IMPORT

- 1) The directive .global functions as either .def if the symbol is defined in the current module, or .ref otherwise. PUBLIC or EXTERN must be used as applicable with the A430 assembler to replace the .global directive.
- 2) The concept of macro libraries is not supported. Include files with macro definitions must be used for this functionality.

Modules may be used with the Asm430 assembler to create individually linkable routines. A file may contain multiple modules or routines. All symbols except those created by DEFINE, #define (IAR preprocessor directive) or MACRO are “undefined” at module end. Library modules are, furthermore, linked conditionally. This means that a library module is only included in the linked executable if a public symbol in the module is referenced externally. The following directives are used to mark the beginning and end of modules in the A430 assembler.

Additional A430 Directives (IAR)	A430 Directive (IAR)
Start a program module	NAME or PROGRAM
Start a library module	MODULE or LIBRARY
Terminate the current program or library module	ENDMOD

## E.2.7 Conditional-Assembly Directives

Description	Asm430 Directive (TI)	A430 Directive (IAR)
Optional repeatable block assembly	.break	See Note 1
Begin conditional assembly	.if	IF
Optional conditional assembly	.else	ELSE
Optional conditional assembly	.elseif	ELSEIF
End conditional assembly	.endif	ENDIF
End repeatable block assembly	.endloop	ENDR
Begin repeatable block assembly	.loop	REPT

- 1) There is no directive that directly corresponds to .break. However, the EXITM directive can be used with other conditionals if repeatable block assembly is used in a macro, as shown:

```

SEQ      MACRO FROM,TO          ; Initialize a sequence of byte constants
        LOCAL X

X        SET      FROM
        REPT     TO-FROM+1     ; Repeat from FROM to TO
        IF      X>255         ; Break if X exceeds 255
        EXITM
        ENDIF
        DB      X             ; Initialize bytes to FROM...TO

```

X            SET            X+1            ; Increment counter  
              ENDR  
              ENDM

Additional A430 Directives (IAR)	A430 Directive (IAR)
Repeatable block assembly: Formal argument is substituted by each character of a string.	REPTC
Repeatable block assembly: formal argument is substituted by each string of a list of actual arguments.	REPTI
See also <i>Preprocessor Directives</i>	

### E.2.8 Symbol Control Directives

The scope of assembly-time symbols differs in the two assemblers. In Asm430, definitions are global to a file, but can be undefined with the `.newblock` directive. In A430, symbols are either local to a macro (LOCAL), local to a module (EQU) or global to a file (DEFINE). In addition, the preprocessor directive `#define` can also be used to define local symbols.

Description	Asm430 Directive (TI)	A430 Directive (IAR)
Assign a character string to a substitution symbol	<code>.asg</code>	SET or VAR or ASSIGN
Undefine local symbols	<code>.newblock</code>	See Note 1
Equate a value with a symbol	<code>.equ</code> or <code>.set</code>	EQU or =
Perform arithmetic on numeric substitution symbols	<code>.eval</code>	SET or VAR or ASSIGN
End structure definition	<code>.endstruct</code>	See Note 2
Begin a structure definition	<code>.struct</code>	See Note 2
Assign structure attributes to a label	<code>.tag</code>	See Note 2

- 1) No A430 directive directly corresponds to `.newblock`. However, `#undef` may be used to reset a symbol that was defined with the `#define` directive. Also, macros or modules may be used to achieve the `.newblock` functionality because local symbols are implicitly undefined at the end of a macro or module.
- 2) Definition of structure types is not supported. Similar functionality is achieved by using macros to allocate aggregate data and base address plus symbolic offset, as shown below:

```

MYSTRUCT:MACRO
    DS 4
    ENDM
LO    DEFINE 0
HI    DEFINE 2

X     RSEG DATA16_Z
     MYSTRUCT

     RSEG CODE
     MOV X+LO,R4
     ...
    
```

Additional A430 Directives (IAR)	A430 Directive (IAR)
Define a file-wide symbol	DEFINE
Definition of special function registers (byte size)	SFRB
Definition of special function registers (word size)	SFRW

**E.2.9 Macro Directives**

Description	Asm430 Directive (TI)	A430 Directive (IAR)
Define a macro	.macro	MACRO
Exit prematurely from a macro	.mexit	EXITM
End macro definition	.endm	ENDM

Additional A430 Directives (IAR)	A430 Directive (IAR)
Create symbol, local to a macro	LOCAL (See Note 1)

- 1) In Asm430 local symbols are suffixed by a question mark (?).

**E.2.10 Miscellaneous Directives**

Description	Asm430 Directive (TI)	A430 Directive (IAR)
Send user-defined error messages to the output device	.emsg	#error
Send user-defined messages to the output device	.mmsg	#message (See Note 1)
Send user-defined warning messages to the output device	.wmsg	See Note 2
Define a load address label	.label	See Note 3
Directive produced by absolute lister	.setsect	ASEG (See Note 4)
Directive produced by absolute lister	.setsym	EQU or = (See Note 4)
Program end	.end	END

- 1) The syntax of the #message directive is: #message "<string>"  
This causes '#message <string>' to be output to the project build window during assemble/compile time.
- 2) Warning messages cannot be user-defined. #message may be used, but the warning counter will not be incremented.
- 3) The concept of load-time addresses is not supported. Run-time and load-time addresses are assumed to be the same. To achieve the same effect, labels can be given absolute (run-time) addresses by the EQU directives.

```

; Asm430 code                                ; A430 code
.label load_start                            load_start:
Run_start:                                   <code>
<code>                                       load_end:
Run_end:                                     run_start:EQU 240H
.label load_end                               run_end: EQU run_start+load_end-load_start

```

- 4) Although not produced by the absolute lister ASEG defines absolute segments and EQU can be used to define absolute symbols.

```

MYFLAG EQU 23EH                               ; MYFLAG is located at 23E
ASEG 240H                                     ; Absolute segment at 240
MAIN: MOV #23CH, SP                           ; MAIN is located at 240
...

```

Additional A430 Directives (IAR)	A430 Directive (IAR)
Set the default base of constants	RADIX
Enable case sensitivity	CASEON
Disable case sensitivity	CASEOFF

### E.2.11 Preprocessor Directives

The A430 assembler includes a preprocessor similar to that used in C programming. The following preprocessor directives can be used in include files which are shared by assembly and C programs.

Additional A430 Directives (IAR)	A430 Directive (IAR)
Assign a value to a preprocessor symbol	#define
Undefine a preprocessor symbol	#undef
Conditional assembly	#if, #else, #elif
Assemble if a preprocessor symbol is defined (not defined)	#ifdef, #ifndef
End a #if, #ifdef or #ifndef block	#endif
Includes a file	#include
Generate an error	#error

### E.2.12 Alphabetical Listing and Cross Reference of Asm430 Directives

Asm430 Directive	A430 Directive	Asm430 Directive	A430 Directive
.align	See <i>Section control directives</i>	.loop	REPT
.asg	SET or VAR or ASSIGN	.macro	MACRO
.break	See <i>Conditional-Assembly Directives</i>	.mexit	EXITM
.bss	See <i>Symbol Control Directives</i>	.mlib	See <i>File Referencing Directives</i>
.byte or .string	DB	.mlist	LSTEXP+ (macro)
.copy or .include	#include or \$		LSTREP+ (loop blocks)
.data	RSEG	.mmsg	#message (XXXXXX)
.def	PUBLIC or EXPORT	.mnolist	LSTEXP- (macro)
.double	Not supported		LSTREP- (loop blocks)
.else	ELSE	.newblock	See <i>Symbol Control Directives</i>
.elseif	ELSEIF	.nolist	LSTOUT-
.emsg	#error	.option	See <i>Listing Control Directives</i>
.end	END	.page	PAGE
.endif	ENDIF	.ref	EXTERN or IMPORT
.endloop	ENDR	.sect	RSEG
.endm	ENDM	.setsect	See <i>Miscellaneous Directives</i>
.endstruct	See <i>Symbol Control Directives</i>	.setsym	See <i>Miscellaneous Directives</i>
.equ or .set	EQU or =	.space	DS
.eval	SET or VAR or ASSIGN	.sslist	Not supported
.even	EVEN	.ssnolist	Not supported
.fclist	LSTCND-	.string	DB
.fcnolist	LSTCND+	.struct	See <i>Symbol Control Directives</i>
.field	See <i>Constant Initialization Directives</i>	.tag	See <i>Symbol Control Directives</i>
.float	See <i>Constant Initialization Directives</i>	.text	RSEG
.global	See <i>File Referencing Directives</i>	.title	See <i>Listing Control Directives</i>
.if	IF	.usect	See <i>Symbol Control Directives</i>
.label	See <i>Miscellaneous Directives</i>	.width	COL
.length	PAGSIZ	.wmsg	See <i>Miscellaneous Directives</i>
.list	LSTOUT+	.word	DW

### E.2.13 Additional A430 Directives (IAR)

Conditional-Assembly Directives	Constant Initialization Directives	Macro Directives
REPTC	DL	LOCAL
REPTI		
File Referencing Directives	Miscellaneous Directives	Symbol Control Directives

---

NAME or PROGRAM	RADIX	DEFINE
MODULE or LIBRARY	CASEON	SFRB
ENDMOD	CASEOFF	SFRW
<b>Listing Control Directives</b>	<b>Preprocessor Directives</b>	<b>Symbol Control Directives</b>
LSTMAC (+/-)	#define	ASEG
LSTCOD (+/-)	#undef	RSEG
LSTPAG (+/-)	#if, #else, #elif	COMMON
LSTXREF (+/-)	#ifdef, #ifndef	STACK
	#endif	ALIGN
	#include	ORG
	#error	

# MSP-FET430UIF Installation Guide

---

---

---

This section describes the hardware installation process of the MSP-FET430UIF USB debug interface on a PC running Windows XP. The installation procedure for a Windows 2000 system is similar and therefore not shown here.

Topic	Page
F.1 Hardware Installation	F-2

## F.1 Hardware Installation

- 1) Connect the MSP-FET430UIF USB Debug Interface with a USB cable to a USB port of your PC
- 2) Windows now should recognize the new hardware as an “MSP430 USB FET x.xx.xx” (see Figure F-1).



Figure F-1. WinXP Hardware Recognition

- 3) The Hardware Wizard should start automatically and popup the “Found New Hardware Wizard” dialog window.
- 4) Instruct the Wizard to install the hardware driver from a specific location (see Figure F-2).

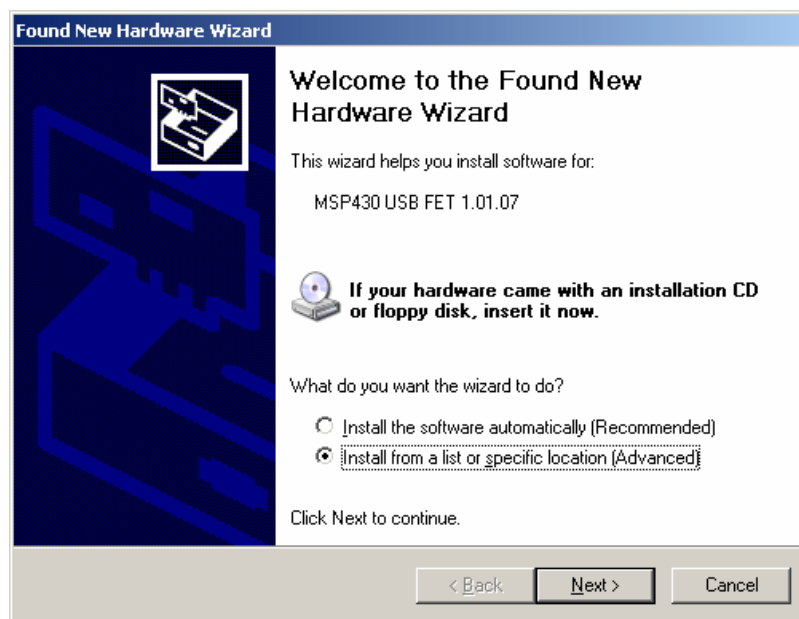
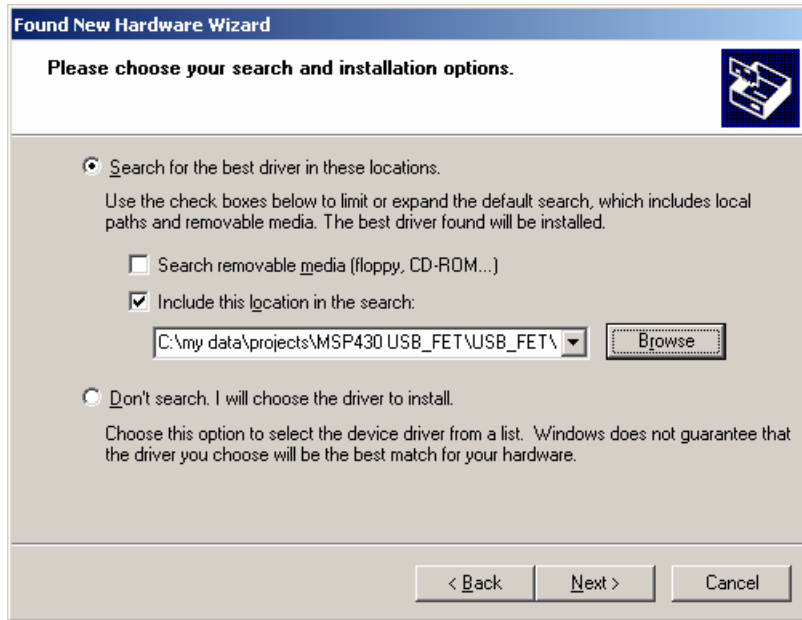

Figure F-2. WinXP Hardware Wizard

- 5) Point the Hardware Wizard to the according folder where the corresponding driver information files are located on your hard disc.



*Figure F-3. WinXP Driver Location Selection Folder*

- 6) The Wizard should generate a message that an appropriate driver has been found.
- 7) Note that WinXP shows a warning that the driver is not certified by Microsoft. Ignore this warning and click "Continue Anyway" (see Figure F-4).

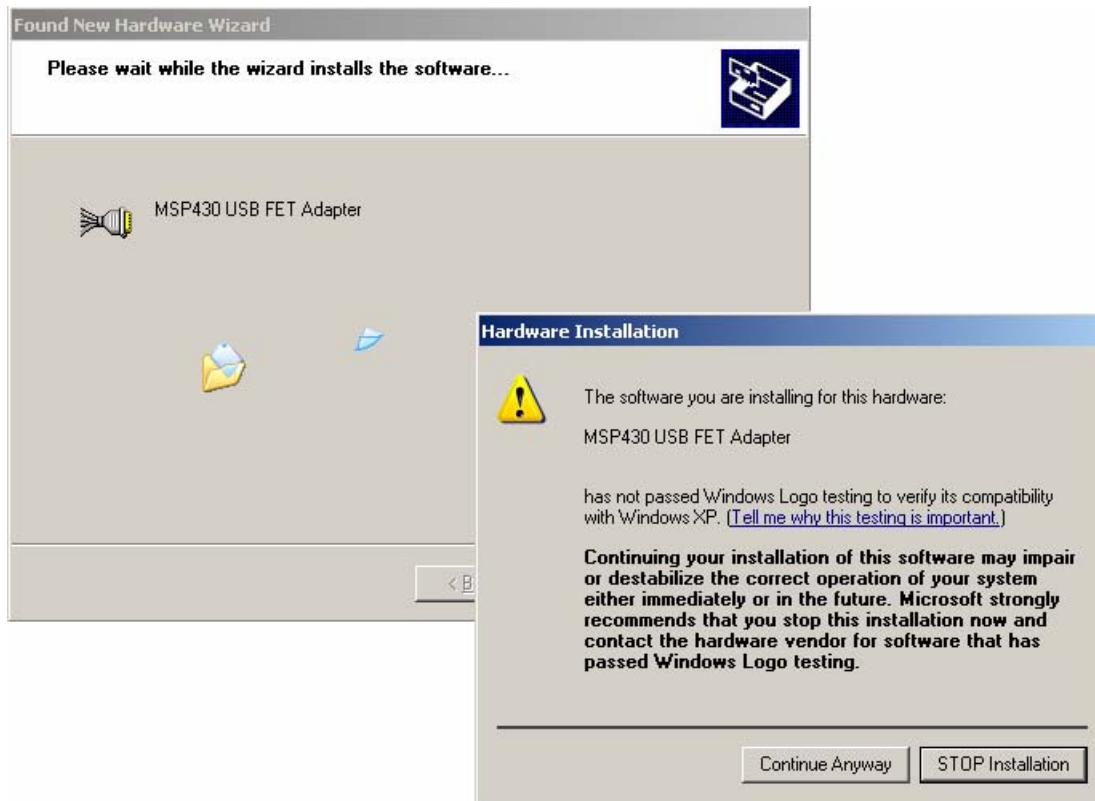

Figure F-4. WinXP Driver Installation

- 8) In the next step, the Wizard installs the driver files.
- 9) The Wizard now shows a message that it has finished the installation of the software for "MSP430 USB FET Adapter".
- 10) After closing the Hardware Wizard, Windows automatically recognizes another new hardware device called "Texas Instruments UMP Serial Port".
- 11) Depending on the current update version of the OS corresponding drivers are installed automatically or the Hardware Wizard pops up again. In case of the Wizard is started, please repeat the steps already described above again
- 12) Finally the MSP-FET430UIF debug interface is installed and ready to use. The Device Manager should list a new entry as shown in Figure F-5.

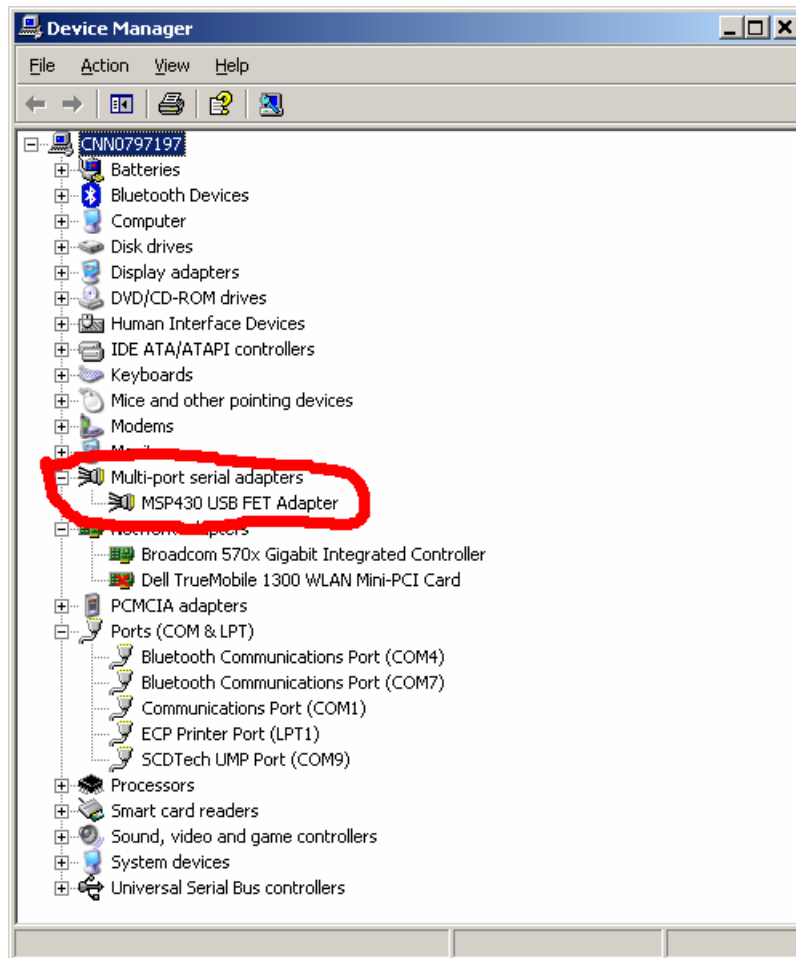

Figure F-5. Device Manager