

## LDC1000 Inductance to Digital Converter

Check for Samples: [LDC1000](#)

### FEATURES

- Magnet-Free Operation
- Sub-Micron Precision
- Adjustable Sensing Range (via Coil Design)
- Lower System Cost
- Remote Sensor Placement (Decoupling the LDC from Harsh Environments)
- High Durability (by Virtue of Contact-Less Operation)
- Insensitivity to Environmental Interference (such as Dirt, Dust, Water, Oil)
- Supply Voltage, Analog: 4.75V to 5.25V
- Supply Voltage, IO: 1.8V to 5.25V
- Supply Current (w/o LC Tank): 1.7mA
- Rp Resolution: 16-bit
- L Resolution: 24-bit
- LC Frequency Range: 5kHz to 5MHz

### APPLICATIONS

- Drive-by-Wire Systems
- Gear-Tooth Counting
- Flow Meters
- Push-Button Switches
- Notebook Computers
- Game Controllers
- Multi-Function Printers
- Digital Cameras
- Medical Devices

### DESCRIPTION

Inductive Sensing is a contact-less, short-range sensing technology that enables low-cost, high-resolution sensing of conductive targets in the presence of dust, dirt, oil, and moisture, making it extremely reliable in hostile environments. Using a coil which can be created on a PCB as a sensing element, the LDC1000 enables ultra-low cost system solutions.

Inductive sensing technology enables precise measurement of linear/angular position, displacement, motion, compression, vibration, metal composition, and many other applications in markets including automotive, consumer, computer, industrial, medical, and communications. Inductive sensing offers better performance and reliability at lower cost than other, competitive solutions.

The LDC1000 is the world's first inductance-to-digital converter, offering the benefits of inductive sensing in a low-power, small-footprint solution. The product is available in a SON-16 package and offers several modes of operation. An SPI interface simplifies connection to an MCU.

### TYPICAL APPLICATION

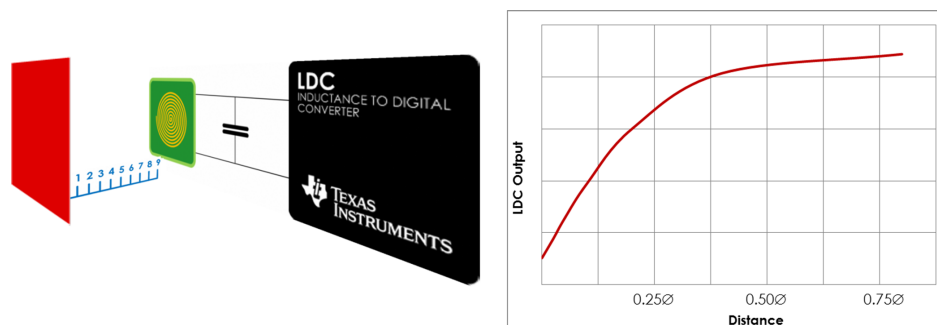

**Figure 1. Axial Distance Sensing**



Please be aware that an important notice concerning availability, standard warranty, and use in critical applications of Texas Instruments semiconductor products and disclaimers thereto appears at the end of this data sheet.



This integrated circuit can be damaged by ESD. Texas Instruments recommends that all integrated circuits be handled with appropriate precautions. Failure to observe proper handling and installation procedures can cause damage.

ESD damage can range from subtle performance degradation to complete device failure. Precision integrated circuits may be more susceptible to damage because very small parametric changes could cause the device not to meet its published specifications.

### BLOCK DIAGRAM

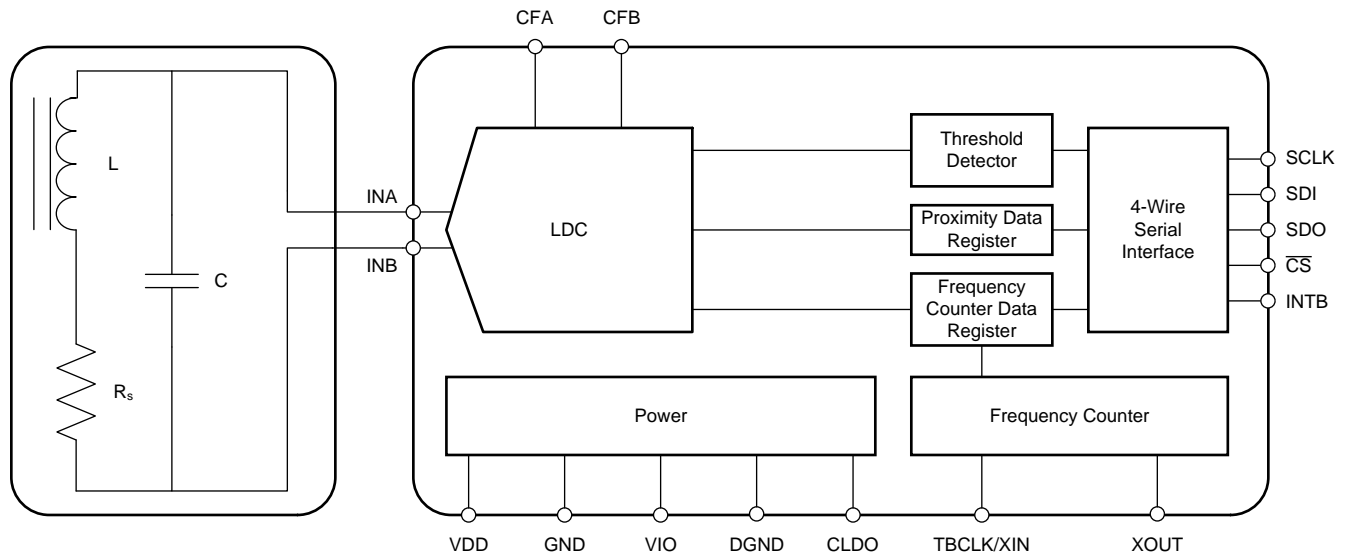

Figure 2. LDC1000 Block Diagram

### TYPICAL APPLICATION SCHEMATIC

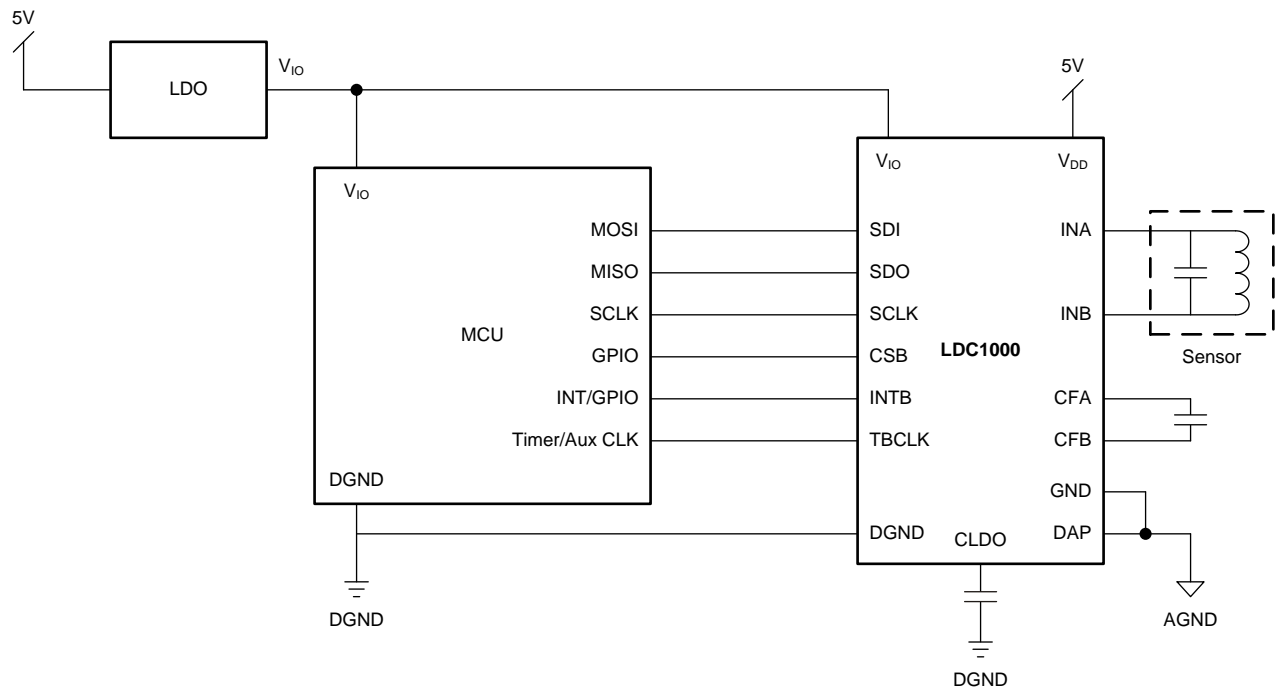

Figure 3. Typical Application Schematic

CONNECTION DIAGRAM

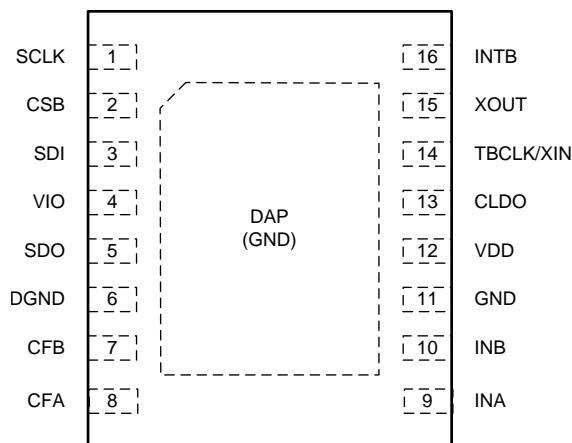

Figure 4. LDC1000 Pin Diagram SON-16

Table 1. Pin Description<sup>(1)</sup>

PIN NAME	PIN NO.	PIN TYPE	FUNCTION
SCLK	1	DO	SPI clock input. SCLK is used to clock-out/clock-in the data from/into the chip
CSB	2	DI	SPI CSB. Multiple devices can be connected on the same SPI bus and CSB can be used to select the device to be communicated with
SDI	3	DI	SPI Slave Data In (Master Out Slave In). This should be connected to the Master Out Slave In of the master
VIO	4	P	Digital IO Supply
SDO	5	DO	SPI Slave Data Out (Master In Slave Out). It is high-z when CSB is high
DGND	6	P	Digital ground
CFB	7	A	LDC filter capacitor
CFA	8	A	LDC filter capacitor
INA	9	A	External LC Tank. Connected to external LC tank
INB	10	A	External LC Tank. Connected to external LC tank
GND	11	P	Analog ground
VDD	12	P	Analog supply
CLDO	13	A	LDO bypass capacitor. A 56nF capacitor should be connected from this pin to GND
TBCLK/XIN	14	DI/A	External time-base clock/XTAL. Either an external clock or crystal can be connected
XOUT	15	A	XTAL. Crystal out. Recommended to connect 8Mhz crystal between XIN and XOUT with 20pF cap from each pin to ground. Should be floating when external clock is used
INTB	16	DO	Configurable interrupt. This pin can be configured to behave in 3 different ways by programming the INT pin mode register. Either threshold detect, wakeup, or DRDYB
DAP	17	P	Connect to GND

(1) DO: Digital Output, DI: Digital Input, P: Power, A: Analog

**ABSOLUTE MAXIMUM RATINGS<sup>(1)</sup>**

ESD Tolerance <sup>(2)</sup>	Human Body Model	1kV
	Charge Device Model	250V
Analog Supply Voltage (VDD – GND)		6V
IO Supply Voltage (VIO – GND)		6V
Voltage on any Analog Pin		-0.3V to VDD + 0.3V
Voltage on any Digital Pin		-0.3V to VIO + 0.3V
Input Current on INA and INB		8mA
Junction Temperature, T <sub>J</sub> <sup>(3)</sup>		+150°C
Storage Temperature Range, T <sub>stg</sub>		-65°C to +150°C

- (1) Absolute Maximum Ratings are limits beyond which damage to the device may occur. Exposure to absolute-maximum-rated conditions for extended periods may affect device reliability. Operating Ratings are conditions under which operation of the device is intended to be functional. For ensured specifications and test conditions, see the Electrical Characteristics.
- (2) The human body model is a 100pF capacitor discharged through a 1.5kΩ resistor into each pin.
- (3) The maximum power dissipation is a function of T<sub>J</sub>(MAX), θ<sub>JA</sub>, and the ambient temperature, T<sub>A</sub>. The maximum allowable power dissipation at any ambient temperature is PD<sub>MAX</sub> = (T<sub>J</sub>(MAX) - T<sub>A</sub>) / θ<sub>JA</sub>. All numbers apply for packages soldered directly onto a PC board. The package thermal impedance is calculated in accordance with JESD 51-7.

**RECOMMENDED OPERATING CONDITIONS<sup>(1)</sup>**

	MIN	MAX	UNIT
Analog Supply Voltage (VDD – GND)	4.75	5.25	V
IO Supply Voltage (VIO – GND)	1.8	5.25	V
VDD-VIO	>=0		V
Operating Temperature, T <sub>A</sub>	-40	125	°C
Package Thermal Resistance <sup>(2)</sup>	SON (θ <sub>JA</sub> )		28 °C/W

- (1) Absolute Maximum Ratings are limits beyond which damage to the device may occur. Exposure to absolute-maximum-rated conditions for extended periods may affect device reliability. Operating Ratings are conditions under which operation of the device is intended to be functional. For ensured specifications and test conditions, see the Electrical Characteristics.
- (2) The maximum power dissipation is a function of T<sub>J</sub>(MAX), θ<sub>JA</sub>, and the ambient temperature, T<sub>A</sub>. The maximum allowable power dissipation at any ambient temperature is PD<sub>MAX</sub> = (T<sub>J</sub>(MAX) - T<sub>A</sub>) / θ<sub>JA</sub>. All numbers apply for packages soldered directly onto a PC board. The package thermal impedance is calculated in accordance with JESD 51-7.

**ELECTRICAL CHARACTERISTICS<sup>(1)</sup>**

 Unless otherwise specified, all limits ensured for TA = TJ = 25°C, VDD = 5.0V, VIO = 3.3V<sup>(2)</sup>

SYMBOL	PARAMETER	CONDITIONS/ COMMENTS	MIN <sup>(3)</sup>	TYP <sup>(4)</sup>	MAX <sup>(3)</sup>	UNITS
<b>POWER</b>						
V <sub>DD</sub>	Analog Supply Voltage		4.75	5	5.25	V
V <sub>IO</sub>	IO Supply Voltage	V <sub>IO</sub> ≤ V <sub>DD</sub>	1.8	3.3	5.25	V
I <sub>DD</sub>	Supply Current, VDD	Does not include LC tank current		1.7	2.3	mA
I <sub>VIO</sub>	IO Supply Current	Static current			14	uA
I <sub>DD_LP</sub>	Low-Power Mode Supply Current	With out LC Tank		250		uA
t <sub>START</sub>	Start-Up Time	From POR to ready-to-convert. Crystal not used for frequency counter		2		ms
<b>LDC</b>						
f <sub>sensor_MIN</sub>	Minimum sensor frequency			5		kHz
f <sub>sensor_MAX</sub>	Maximum sensor frequency			5		MHz
A <sub>sensor_MIN</sub>	Minimum sensor amplitude			1		V <sub>PP</sub>
A <sub>sensor_MAX</sub>	Maximum sensor amplitude			4		V <sub>PP</sub>
t <sub>REC</sub>	Recovery time	Oscillation start-up time after RP under-range condition		10		1/f <sub>sensor</sub>
R <sub>p_MIN</sub>	Minimum Sensor Rp Range			798		Ω
R <sub>p_MAX</sub>	Maximum Sensor Rp Range			3.93M		Ω
R <sub>p_RES</sub>	Rp Measurement Resolution			16		Bits
t <sub>S_MIN</sub>	Minimum Response Time	Minimum programmable settling time of digital filter		192 × 1/f <sub>sensor</sub>		s
t <sub>S_MAX</sub>	Maximum Response Time	Maximum programmable settling time of digital filter		6144 × 1/f <sub>sensor</sub>		s
<b>EXTERNAL CLOCK/CRYSTAL FOR FREQUENCY COUNTER</b>						
Crystal	Frequency			8		MHz
	Startup time			30		ms
External Clock	Frequency				8	MHz
	Clock Input High Voltage				V <sub>IO</sub>	V

- (1) Electrical Characteristics Table values apply only for factory testing conditions at the temperature indicated. Factory testing conditions result in very limited self-heating of the device such that TJ = TA. No specification of parametric performance is indicated in the electrical tables under conditions of internal self-heating where TJ > TA. Absolute Maximum Ratings indicate junction temperature limits beyond which the device may be permanently degraded, either mechanically or electrically.
- (2) The maximum power dissipation is a function of TJ(MAX), θJA, and the ambient temperature, TA. The maximum allowable power dissipation at any ambient temperature is PD<sub>MAX</sub> = (TJ(MAX) - TA) / θJA. All numbers apply for packages soldered directly onto a PC board. The package thermal impedance is calculated in accordance with JESD 51-7.
- (3) Limits are specified by testing, design, or statistical analysis at 25°C. Limits over the operating temperature range are specified through correlations using statistical quality control (SQC) method.
- (4) Typical values represent the most likely parametric norm as determined at the time of characterization. Actual typical values may vary over time and will also depend on the application and configuration. The typical values are not tested and are not specified on shipped production material.

**ELECTRICAL CHARACTERISTICS<sup>(1)</sup> (continued)**

Unless otherwise specified, all limits ensured for TA = TJ = 25°C, VDD = 5.0V, VIO = 3.3V<sup>(2)</sup>

SYMBOL	PARAMETER	CONDITIONS/ COMMENTS	MIN <sup>(3)</sup>	TYP <sup>(4)</sup>	MAX <sup>(3)</sup>	UNITS
<b>DIGITAL I/O CHARACTERISTICS</b>						
V <sub>IH</sub>	Logic "1" Input Voltage		0.8×V <sub>IO</sub>			V
V <sub>IL</sub>	Logic "0" Input Voltage				0.2×V <sub>IO</sub>	V
V <sub>OH</sub>	Logic "1" Output Voltage	ISOURCE=400uA		V <sub>IO</sub> -0.3		V
V <sub>OL</sub>	Logic "0" Output Voltage	ISINK=400uA			0.3	V
I <sub>IOHL</sub>	Digital IO Leakage Current		-500		500	nA

TIMING DIAGRAMS

Unless otherwise noted, all limits specified at TA = 25°C, VDD=5.0, VIO=3.3, 10pF capacitive load in parallel with a 10kΩ load on SDO. Specified by design; not production tested.

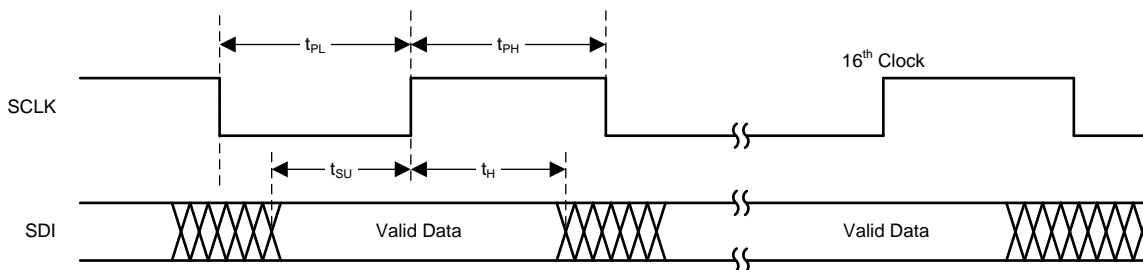

Figure 5. Write Timing Diagram

Table 2.

PARAMETER		CONDITIONS	MIN	TYP	MAX	UNIT
F <sub>SCLK</sub>	Serial Clock Frequency				4	MHz
t <sub>PH</sub>	SCLK Pulse Width High	F <sub>SCLK</sub> =4Mhz	0.4/Fsclk			s
t <sub>PL</sub>	SCLK Pulse Width Low	F <sub>SCLK</sub> =4Mhz	0.4/Fsclk			s
t <sub>SU</sub>	SDI Setup Time		10			ns
t <sub>H</sub>	SDI Hold Time		10			ns

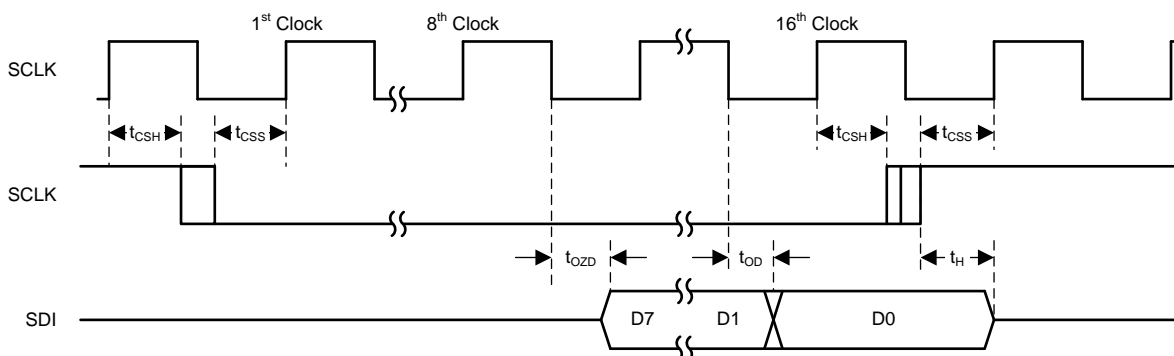

Figure 6. Read Timing Diagram

PARAMETER		CONDITIONS	MIN	TYP	MAX	UNIT
t <sub>ODZ</sub>	SDO Driven-to-Tristate Time	Measured at 10% / 90% point			20	ns
t <sub>OZD</sub>	SDO Tristate-to-Driven Time	Measured at 10% / 90% point			20	ns
t <sub>OD</sub>	SDO Output Delay Time				20	ns
t <sub>CSS</sub>	CSB Setup Time		20			ns
t <sub>CSH</sub>	CSB Hold Time		20			ns
t <sub>IAG</sub>	Inter-Access Gap		100			ns
t <sub>DRDYB</sub>	Data ready pulse width	Data ready pulse at every 1/ODR if no data is read		1/f <sub>sensor</sub>		s

## THEORY OF OPERATION

### Inductive Sensing

An AC current flowing through a coil will generate an AC magnetic field. If a conductive material, such as a metal target, is brought into the vicinity of the coil, this magnetic field will induce circulating currents (eddy currents) on the surface of the target. These eddy currents are a function of the distance, size, and composition of the target. These eddy currents then generate their own magnetic field, which opposes the original field generated by the coil. This mechanism is best compared to a transformer, where the coil is the primary core and the eddy current is the secondary core. The inductive coupling between both cores depends on distance and shape. Hence the resistance and inductance of the secondary core (Eddy current), shows up as a distant dependent resistive and inductive component on the primary side (coil). The figures below show a simplified circuit model.

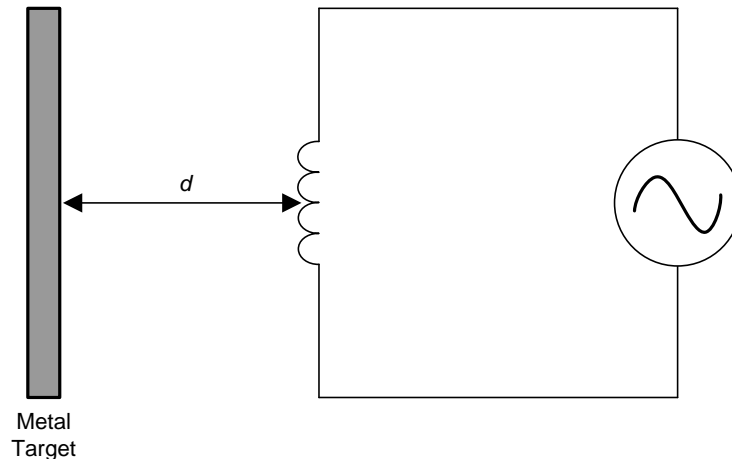

**Figure 7. Inductor with a Metal Target**

Eddy currents generated on the surface of the target can be modeled as a transformer as shown in [Figure 8](#). The coupling between the primary and secondary coils is a function of the distance and conductor's characteristics. In [Figure 8](#), the inductance  $L_s$  is the coil's inductance, and  $R_s$  is the coil's parasitic series resistance. The inductance  $L(d)$ , which is a function of distance  $d$ , is the coupled inductance of the metal target. Likewise,  $R(d)$  is the parasitic resistance of the eddy currents.

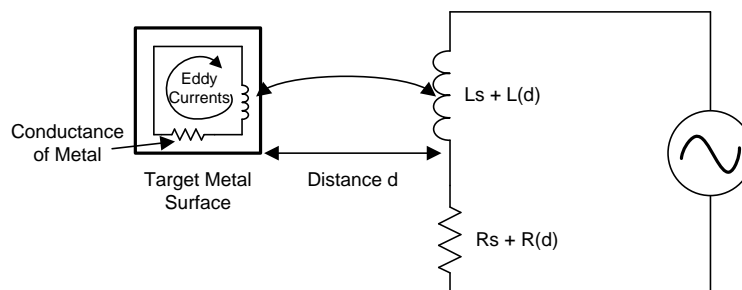

**Figure 8. Metal Target Modeled as L and R with Circulating Eddy Currents**



Generating an alternating magnetic field with just an inductor will consume a large amount of power. This power consumption can be reduced by adding a parallel capacitor, turning it into a resonator as shown in [Figure 9](#) . In this manner the power consumption is reduced to the eddy and inductor losses  $R_s+R(d)$  only.

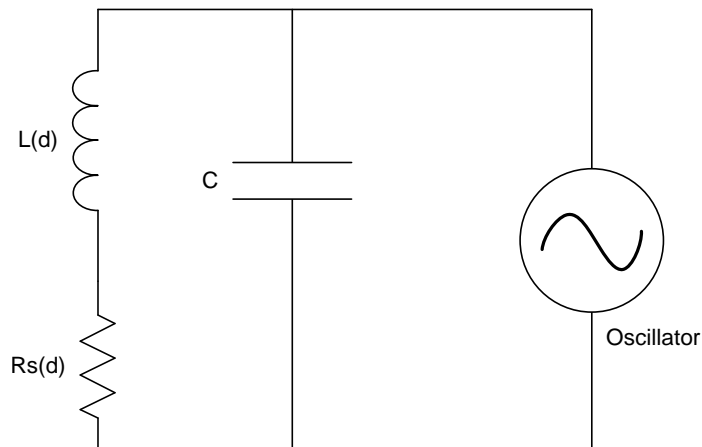

**Figure 9. LC Tank Connected to Oscillator**

The LDC1000 doesn't measure the series resistance directly; instead it measures the equivalent parallel resonance impedance  $R_p$  (see [Figure 10](#)). This representation is equivalent to the one shown in [Figure 10](#) , where the parallel resonance impedance  $R_p(d)$  is given by:  $R_p(d) = (1/([R_s+R(d)])) * ([L_s+L(d)])C$ .

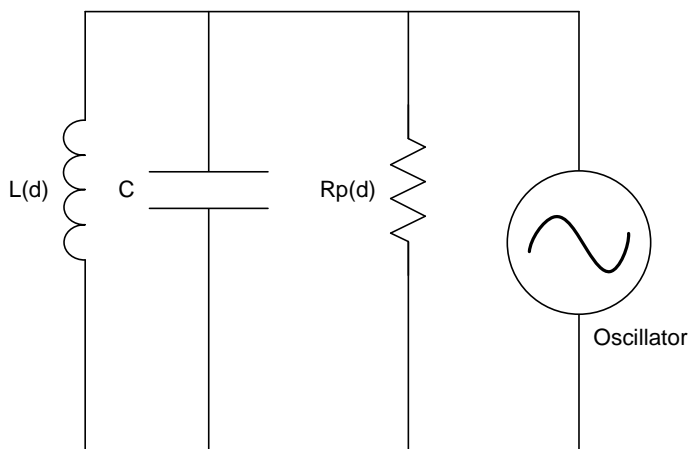

**Figure 10. Equivalent Resistance of  $R_s$  in Parallel with LC Tank**

$$R_p = (1/R_s) * (L/C).$$

Figure 11 below shows the variation in  $R_p$  as a function of distance for a 14mm diameter PCB coil (23 turns, 4 mil trace width, 4mil spacing between trace, 1oz Cu thickness, FR4). Target used is a Stainless steel 2mm thick.

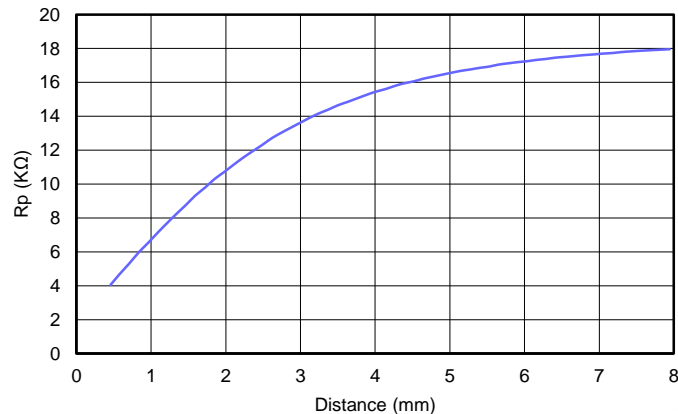

Figure 11. Typical  $R_p$  Vs Distance with 14mm PCB Coil

### Measuring Parallel Resonance Impedance and Inductance with LDC1000

The LDC1000 is an Inductance-to-Digital Converter that simultaneously measures the impedance and resonant frequency of an LC resonator. It accomplishes this task by regulating the oscillation amplitude in a closed loop configuration to a constant level, while monitoring the energy dissipated by the resonator. By monitoring the amount of power injected into the resonator, the LDC1000 can determine the value of  $R_p$ ; it returns this as a digital value which is inversely proportional to  $R_p$ . In addition, the LDC1000 can also measure the oscillation frequency of the LC circuit; this frequency is used to determine the inductance of the LC circuit. The oscillation frequency is returned as a digital value.

The LDC1000 supports a wide range of LC combinations, with oscillation frequencies ranging from 5kHz to 5MHz and  $R_p$  ranging from 798 $\Omega$  to 3.93M $\Omega$ . This range of  $R_p$  can be viewed as the maximum input range of an ADC. As illustrated in Figure 11, the range of  $R_p$  is typically a much smaller than maximum input range supported by the LDC1000. To get better resolution in the desired sensing range, the LDC1000 offers programmable input range through the  $R_p\_MIN$  and  $R_p\_MAX$  registers. Refer to Calculation of  $R_p$  Min and  $R_p$  Max below for how to set these registers.

When the sensor's resonance impedance  $R_p$  drops below the programmed  $R_p\_MIN$ , the LDC's  $R_p$  output will clip at its full scale output. This situation could for example happen when a target comes too close to the coil.

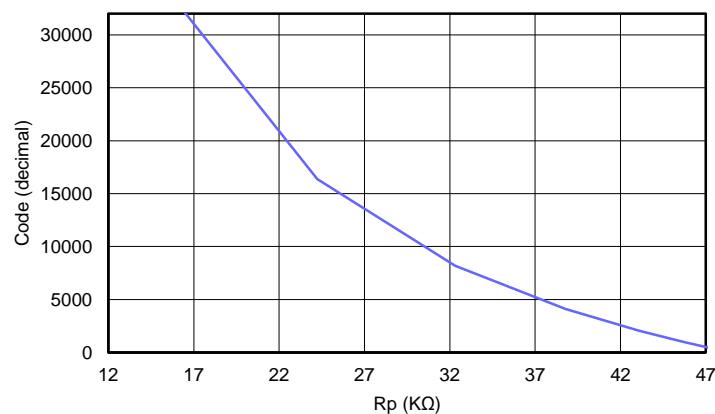

Figure 12. Transfer Characteristics of LDC1000 with  $R_p\_MIN= 16.160$  k $\Omega$  and  $R_p\_MAX= 48.481$  k $\Omega$

The resonance impedance can be calculated from the digital output code as follows:

$$R_p = (R_{pMAX} \times R_{pMIN}) / (R_{pMIN} \times (1-Y) + R_{pMAX} \times Y), \text{ in } \Omega.$$

Where:

- $Y = \text{Proximity Data} / 2^{15}$
- Proximity data is the LDC output, register address 0x21 and 0x22. (1)

**Example:** If Proximity data (address 0x22:0x21) is 5000,  $R_{p\_MIN}$  is 2.394 k $\Omega$ , and  $R_{p\_MAX}$  is 38.785 k $\Omega$ , the resonance impedance is given by:

$$Y = 5000 / 2^{15} = 0.1526$$

$$RP = (38785 \times 2394) / (2394 \times (1 - 0.1526) + 38785 \times 0.1526) = (92851290) / (2028.675 + 5918.591)$$

$$RP = 11.683 \text{ k}\Omega$$

Figure 13 and Figure 14 below show the change in RMS noise versus distance and a histogram of noise, with the target at 0.8mm distance from the sensor coil. Data was collected with a 14mm PCB coil (23 turns, 4 mil trace width, 4mil spacing between trace, 1oz Cu thickness, FR4) with a sensing range of 0.125mm to 1.125mm. At a distance of 0.8mm, the RMS noise is approximately 250nm.

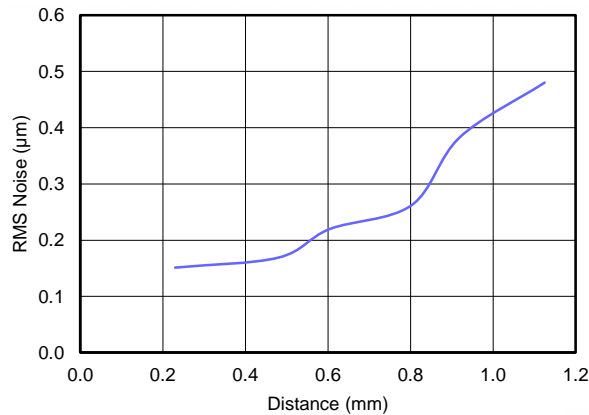

Figure 13. Typical RMS Noise Vs. Distance with PCB Coil

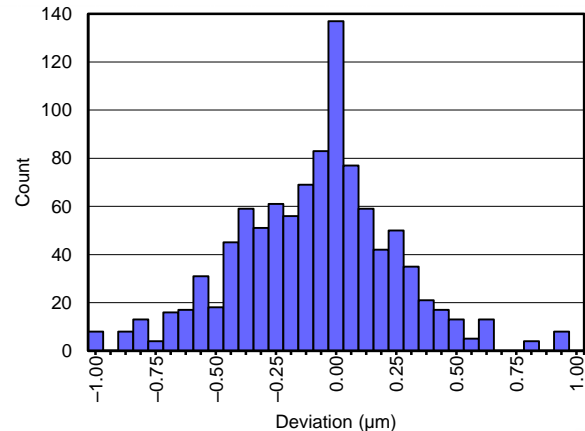

Figure 14. Histogram of Output Codes at 0.8mm Distance

Note that while the LDC1000 has high resolution, its absolute accuracy depends on offset and gain correction which can be achieved by two-point calibration.

### Calculation of $R_p$ Min and $R_p$ Max

Different sensing applications may have a different ranges of the resonance impedance  $R_p$  to measure. The LDC1000 measurement range of  $R_p$  is controlled by setting 2 registers –  $R_{p\_MIN}$  and  $R_{p\_MAX}$ . For a given application,  $R_p$  must never be outside the range set by these register values, otherwise the measured value will be clipped. For optimal sensor resolution, the range of  $R_{p\_MIN}$  to  $R_{p\_MAX}$  should not be unnecessarily large. The following procedure is recommended to determine the  $R_{p\_MIN}$  and  $R_{p\_MAX}$  register values.

#### $R_{p\_MAX}$

$R_{p\_MAX}$  sets the upper limit of the LDC1000 resonant impedance input range.

- Configure the sensor such that the eddy current losses are minimized. As an example, for a proximity sensing application, set the distance between the sensor and the target to the maximum sensing distance.
- Measure the resonant impedance  $R_p$  using an impedance analyzer.
- Multiply  $R_p$  by 2 and use the next higher value from Table 6.

For example, if Rp at 8mm is measured to be 18kΩ, 18000×2 = 36000. In [Table 6](#), then 38.785kΩ is the smallest value larger than 36kΩ; this corresponds to Rp\_MAX value of 0x11.

Note that setting Rp\_MAX to a value not listed in [Table 6](#) can result in indeterminate behavior.

### Rp\_MIN

Rp\_MIN sets the lower limit of the LDC1000 resonant impedance input range.

- Configure the sensor such that the eddy current losses are maximized. As an example, for a proximity sensing application, set the distance between the sensor and the metal target to the minimum sensing distance.
- Measure the resonant impedance Rp using an impedance analyzer.
- Divide the Rp value by 2 and then select the next lower Rp value from [Table 8](#).

For example, if Rp at 1mm is measured to be 5kΩ, 5000/2 = 2500. In [Table 8](#), 2.394kΩ is the smallest value lower than 2.5kΩ; this corresponds to Rp\_MIN value of 0x3B.

Note that setting Rp\_MIN to a value not listed on [Table 8](#) can result in indeterminate behavior. In addition, Rp\_MIN powers on with a default value of 0x14 which must be set to a value from [Table 8](#) prior to powering on the LDC.

### Measuring Inductance

LDC1000 measures the sensor's frequency of oscillation by a frequency counter. The frequency counter timing is set by an external clock or crystal. Either the external clock(8MHz typical) from microcontroller can be provided on the TBCLK pin or a crystal can be connected on the XTALIN and XTALOUT pins. The clock mode is controlled through Clock Configuration register (address 0x05). The sensor resonance frequency is derived from the frequency counter registers value (see registers 0x23 through 0x25) as follows:

Sensor frequency,  $f_{\text{sensor}} = (1/3) * (F_{\text{ext}}/F_{\text{count}}) * (\text{Response Time})$

where  $F_{\text{ext}}$  is the frequency of the external clock or crystal,  $F_{\text{count}}$  is the value obtained from the Frequency Counter Data register(address 0x23,0x24,0x25), and Response Time is the programmed response time (see LDC configuration register, address 0x04).

The Inductance can be calculated as follows:

$$L = 1/[C * (2 * \pi * f_{\text{sensor}})^2], \quad (2)$$

where C is the parallel capacitance of the resonator.

**Example:** If  $F_{\text{ext}}=6\text{Mhz}$ , Response time=6144,  $C=100\text{pF}$  and measured  $F_{\text{count}}= 3000$  (dec) (address 0x23 through 0x25)

$$f_{\text{sensor}} = (1/3) * (6000000/3000) * (6144) = 4.096\text{Mhz}$$

$$\text{Now using, } L = 1/[C * (2 * \pi * f_{\text{sensor}})^2]$$

$$\text{Inductance, } L = 15.098\mu\text{H}$$

The accuracy of measurement largely depends upon the choice of the external time-base clock (TBCLK) or the crystal oscillator (XIN/XOUT).

### Output Data Rate

Output data rate of LDC1000 depends on the sensor frequency,  $f_{\text{sensor}}$  and 'Response Time' field in LDC Configuration register(Address:0x04).

$$\text{Output data rate} = (f_{\text{sensor}}) / (\text{Response Time} / 3), \text{ Sample per second (SPS)}$$

**Example:** If  $f_{\text{sensor}}=5\text{Mhz}$  and Response Time=192

$$\text{Output data rate} = (5\text{M}) / (192/3) = 78.125 \text{ KSPS}$$

## Choosing Filter Capacitor (CFA and CFB Pins)

The Filter capacitor is critical to the operation of the LDC1000. The capacitor should be low leakage, temperature stable, and it must not generate any piezoelectric noise (the dielectrics of many capacitors exhibit piezoelectric characteristics and any such noise is coupled directly through  $R_p$  into the converter). The optimal capacitance values range from 20pF to 100nF. The value of the capacitor is based on the time constant and resonating frequency of the LC tank.

If a ceramic capacitor is used, then a C0G (or NP0) grade dielectric is recommended; the voltage rating should be  $\geq 10V$ . The traces connecting CFA and CFB to the capacitor should be as short as possible to minimize any parasitics.

For optimal performance, the chosen filter capacitor, connected between pins CFA and CFB, needs to be as small as possible, but large enough such that the active filter does not saturate. The size of this capacitor depends on the time constant of the sense coil, which is given by  $L/R_s$ , ( $L$ =inductance,  $R_s$ =series resistance of the inductor at oscillation frequency). The larger this time constant, the larger filter capacitor is required. Hence, this time constant reaches its maximum when there is no target present in front of the sensing coil.

The following procedure can be used to find the optimal filter capacitance:

1. Start with a large filter capacitor. For a ferrite core coil, 10nF is usually large enough. For an air coil or PCB coil, 100pF is usually large enough.
2. Power on the LDC and set the desired register values. Minimize the eddy currents losses by ensuring there is maximum clearance between the target and the sensing coil.
3. Observe the signal on the CFB pin using a scope. Since this node is very sensitive to capacitive loading, it is recommended to use an active probe. As an alternative, a passive probe with a 1k $\Omega$  series resistance between the tip and the CFB pin can be used.
4. Vary the values of the filter capacitor until that the signal observed on the CFB pin has an amplitude of approximate 1V peak-to-peak. This signal scales linearly with the reciprocal of the filter capacitance. For example, if a 100pF filter capacitor is applied and the signal observed on the CFB pin has a peak-to-peak value of 200mV, the desired 1V peak-to-peak value is obtained using a  $200mV / 1V * 100pF = 20pF$  filter capacitor.

The waveforms below were taken on the CFB pin with a 14mm, 2 layer PCB coil(23 turns,4 mil trace width, 4mil spacing between trace,1oz Cu thickness,FR4):

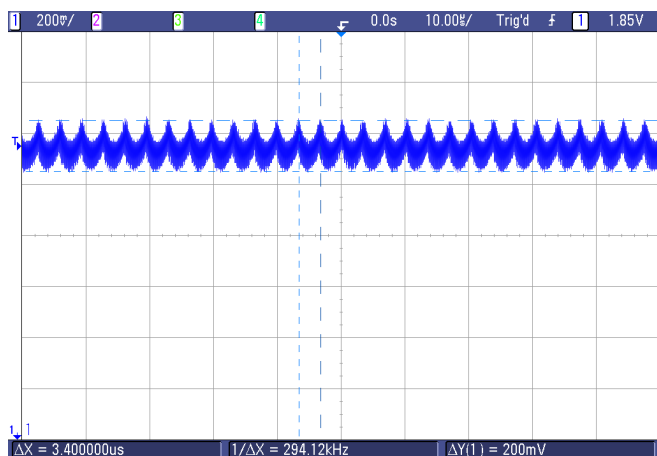

Figure 15. Waveform on CFB with 100pF

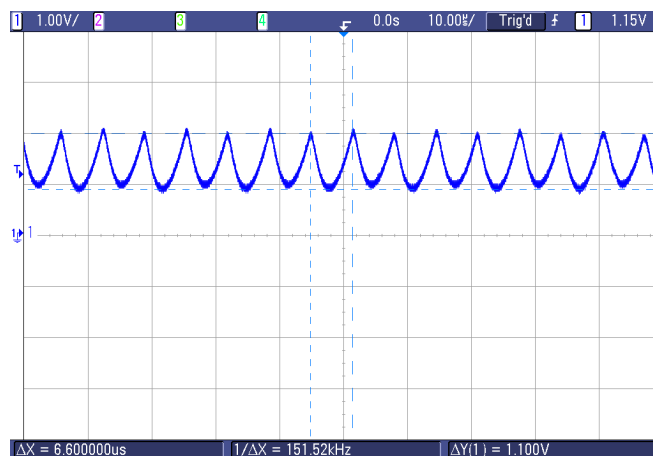

Figure 16. Waveform on CFB with 20pF

## PROGRAMMABLE REGISTERS

**Table 3. Register Map<sup>(1)(2)(3)</sup>**

Register Name	Address	Direction	Default	Bit 7	Bit 6	Bit 5	Bit 4	Bit 3	Bit 2	Bit 1	Bit 0	
Device ID	0x00	RO	0x80	Device ID								
Rp_MAX	0x01	R/W	0x0E	Rp Maximum								
Rp_MIN	0x02	R/W	0x14	Rp Minimum								
Sensor Frequency	0x03	R/W	0x45	Min Resonating Frequency								
LDC Configuration	0x04	R/W	0x1B	Reserved(000)			Amplitude		Response Time			
Clock Configuration	0x05	R/W	0x01	Reserved(000000)						CLK_SE L	CLK_PD	
Comparator Threshold High LSB	0x06	R/W	0xFF	Threshold High LSB								
Comparator Threshold High MSB	0x07	R/W	0xFF	Threshold High MSB								
Comparator Threshold Low LSB	0x08	R/W	0x00	Threshold Low LSB								
Comparator Threshold Low MSB	0x09	R/W	0x00	Threshold Low MSB								
INTB Pin Configuration	0x0A	R/W	0x00	Reserved(00000)					INTB_MODE			
Power Configuration	0x0B	R/W	0x00	Reserved(0000000)								PWR_M ODE
Status	0x20	RO		OSC Dead	DRDYB	Wake-up	Compara tor	Do not Care				
Proximity Data LSB	0x21	RO		Proximity Data[7:0]								
Proximity Data MSB	0x22	RO		Proximity Data[15:8]								
Frequency Counter Data LSB	0x23	RO		ODR LSB								
Frequency Counter Data Mid-Byte	0x24	RO		ODR Mid Byte								
Frequency Counter Data MSB	0x25	RO		ODR MSB								

(1) Values of Bits which are unused should be set to default values only.

(2) Registers 0x01 through 0x05 are Read Only when the part is awake (PWR\_MODE bit is SET)

(3) R/W: Read/Write. RO: Read Only. WO: Write Only.

## Register Description

**Table 4. Revision ID**

Address = 0x00, Default=0x80, Direction=RO		
Bit Field	Field Name	Description
7:0	Revision ID	Revision ID of Silicon.

**Table 5. Rp\_MAX**

Address = 0x01, Default=0x0E, Direction=R/W		
Bit Field	Field Name	Description
7:0	Rp Maximum	Maximum Rp that LDC1000 needs to measure. Configures the input dynamic range of LDC1000. See <a href="#">Table 6</a> for register settings.

**Table 6. Register settings for Rp\_MAX**

Register setting	Rp (kΩ)
0x00	3926.991
0x01	3141.593
0x02	2243.995
0x03	1745.329
0x04	1308.997
0x05	981.748
0x06	747.998
0x07	581.776
0x08	436.332
0x09	349.066
0x0A	249.333
0x0B	193.926
0x0C	145.444
0x0D	109.083
0x0E	83.111
0x0F	64.642
0x10	48.481
0x11	38.785
0x12	27.704
0x13	21.547
0x14	16.160
0x15	12.120
0x16	9.235
0x17	7.182
0x18	5.387
0x19	4.309
0x1A	3.078
0x1B	2.394
0x1C	1.796
0x1D	1.347
0x1E	1.026
0x1F	0.798

**Table 7. Rp\_MIN**

Address = 0x02, Default=0x14, Direction=R/W		
Bit Field	Field Name	Description
7:0	Rp Minimum	Minimum Rp that LDC1000 needs to measure. Configures the input dynamic range of LDC1000. See <a href="#">Table 8</a> for register settings. <sup>(1)</sup>

(1) This Register needs a mandatory write as it defaults to 0x14.

**Table 8. Register Settings for Rp\_MIN**

Register setting	Rp (kΩ)
0x20	3926.991
0x21	3141.593
0x22	2243.995
0x23	1745.329
0x24	1308.997
0x25	981.748
0x26	747.998
0x27	581.776
0x28	436.332
0x29	349.066
0x2A	249.333
0x2B	193.926
0x2C	145.444
0x2D	109.083
0x2E	83.111
0x2F	64.642
0x30	48.481
0x31	38.785
0x32	27.704
0x33	21.547
0x34	16.160
0x35	12.120
0x36	9.235
0x37	7.182
0x38	5.387
0x39	4.309
0x3A	3.078
0x3B	2.394
0x3C	1.796
0x3D	1.347
0x3E	1.026
0x3F	0.798

**Table 9. Sensor Frequency<sup>(1)(2)</sup>**

Address = 0x03, Default=0x45, Direction=R/W		
Bit Field	Field Name	Description
7:0	Min Resonating Frequency	Sets the minimum resonating frequency to approximately 20% below the lowest resonating frequency of the sensor with no target in front. Use the formula below to determine the value of register.

(1)  $N = 68.94 * \log_{10}(F/2000)$

**F** = 20% below resonating frequency, Hz

**N** = Register Value. Round to nearest value.

(2) **Example:**

**Sensor Frequency:** 1MHz

**F** = 0.8\*1Mhz=800Khz

**N** =  $68.94 * \log_{10}(800KHz/2000)$ = Round to nearest(179.38)=179 (Value to be programmed in Sensor Frequency register)



**Table 10. LDC Configuration**

Address = 0x04, Default=0x1B, Direction=R/W		
Bit Field	Field Name	Description
7:5	Reserved	Reserved to 0
4:3	Amplitude	Sets the oscillation amplitude 00:1V 01:2V 10:4V <b>11:Reserved</b>
2:0	Response Time	000: Reserved 001: Reserved 010: 192 <b>011: 384</b> 100: 768 101: 1536 110: 3072 111: 6144

**Table 11. Clock Configuration**

Address = 0x05, Default=0x01, Direction=R/W		
Bit Field	Field Name	Description
7:2	Reserved	Reserved to 0
1	CLK_SEL	1:External Crystal used for Frequency Counter (XIN/XOUT). <b>0:External Time-Base Clock used for Frequency Counter (TBCLK).</b>
0	CLK_PD	<b>1:Disable External time base clock. Crystal Oscillator Power Down.</b> 0:Enable External time base clock.

**Table 12. Comparator Threshold High LSB**

Address = 0x06, Default=0xFF, Direction=R/W		
Bit Field	Field Name	Description
7:0	Threshold High LSB Threshold High[7:0]	Least Significant byte of Threshold High Register. This register is a buffer. Read will reflect the current value of Threshold High [7:0]. See register 0x07 for details on Updating the Threshold High register.

**Table 13. Comparator Threshold High MSB**

Address = 0x07, Default=0xFF, Direction=R/W		
Bit Field	Field Name	Description
7:0	Threshold High MSB Threshold High[15:8]	Most Significant byte of Threshold High Register. Write to this register copies the contents of 0x06 register and Writes to Threshold High register[15:0]. Read will return Threshold high [15:8]. To Update Threshold high register write register 0x06 first and then 0x07.

**Table 14. Comparator Threshold Low LSB**

Address = 0x08, Default=0x00, Direction=R/W		
Bit Field	Field Name	Description
7:0	Threshold Low LSB Threshold Low[7:0]	Least Significant byte of Threshold Low Value. This register is a buffer. Read will reflect the current value of Threshold Low [7:0]. See register 0x09 for details on Updating the Threshold Low register.

**Table 15. Comparator Threshold Low MSB**

Address = 0x09, Default=0x00, Direction=R/W		
Bit Field	Field Name	Description
7:0	Threshold Low MSB Threshold Low[15:8]	Most Significant byte of Threshold Low Register. Write to this register copies the contents of 0x08 register and Writes to Threshold Low register[15:0]. Read will return Threshold Low [15:8]. To Update Threshold low register write register addr 0x08 first and then 0x09.

**Table 16. INTB Pin Configuration**

Address = 0x0A, Default=0x00, Direction=R/W		
Bit Field	Field Name	Description
7:3	Reserved	Reserved to 0
2:0	Mode	100: DRDYB Enabled on INTB pin
		010: INTB pin indicates the status of Comparator output
		001: Wake-up Enabled on INTB pin
		<b>000: All modes disabled</b>
		All other combinations are Reserved

**Table 17. Power Configuration**

Address = 0x0B, Default=0x00, Direction=R/W		
Bit Field	Field Name	Description
7:1	Reserved	Reserved to 0
0	PWR_MODE	<b>0:Stand-By mode</b> 1:Active Mode. Conversion is Enabled

**Table 18. Status**

Address = 0x20, Default=NA, Direction=RO		
Bit Field	Field Name	Description
7	OSC status	1:Indicates oscillator overloaded and stopped
		0:Oscillator working
6	Data Ready	0:Data is ready to be read
		1:No new data available
5	Wake-up	0:Wake-up triggered. Proximity data is more than Threshold High value.
		1:Wake-up disabled
4	Comparator	0:Proximity data is more than Threshold High value
		1:Proximity data is less than Threshold Low value
3:0	Do not Care	

**Table 19. Proximity Data LSB**

Address = 0x21, Default=NA, Direction=RO		
Bit Field	Field Name	Description
7:0	Proximity Data[7:0]	Least Significant Byte of Proximity Data

**Table 20. Proximity Data MSB**

Address = 0x22, Default=NA, Direction=RO		
Bit Field	Field Name	Description
7:0	Proximity data [15:8]	Most Significant Byte of Proximity data

**Table 21. Frequency Counter LSB**

Address = 0x23, Default=NA, Direction=RO		
Bit Field	Field Name	Description
7:0	ODR LSB (ODR[7:0])	LSB of Output data rate. Sensor frequency can be calculated using the output data rate. Please refer to the <a href="#">Measuring Inductance</a> .

**Table 22. Frequency Counter Mid-Byte**

Address = 0x24, Default=NA, Direction=RO		
Bit Field	Field Name	Description
7:0	ODR Mid byte (ODR[15:8])	Middle Byte of Output data rate

**Table 23. Frequency Counter MSB**

Address = 0x25, Default=NA, Direction=RO		
Bit Field	Field Name	Description
7:0	ODR MSB (ODR[23:16])	MSB of Output data rate

Care must be taken to ensure that Proximity Data[15:0] and Frequency Counter[23:0] are all from same conversion. Conversion data is updated to these registers only when a read is initiated on 0x21 register. If the read is delayed between subsequent conversions, these registers are not updated until another read is initiated on 0x21.

**DIGITAL INTERFACE**

The LDC1000 utilizes a 4-wire SPI interface to access control and data registers. The LDC1000 is an SPI slave device and does not initiate any transactions.

**SPI Description**

A typical serial interface transaction begins with an 8-bit instruction, which is comprised of a read/write bit (MSB, R=1) and a 7 bit address of the register, followed by a Data field which is typically 8 bits. However, the data field can be extended to a multiple of 8 bits by providing sufficient SPI clocks. Refer to the [Extended SPI Transactions](#) section below.

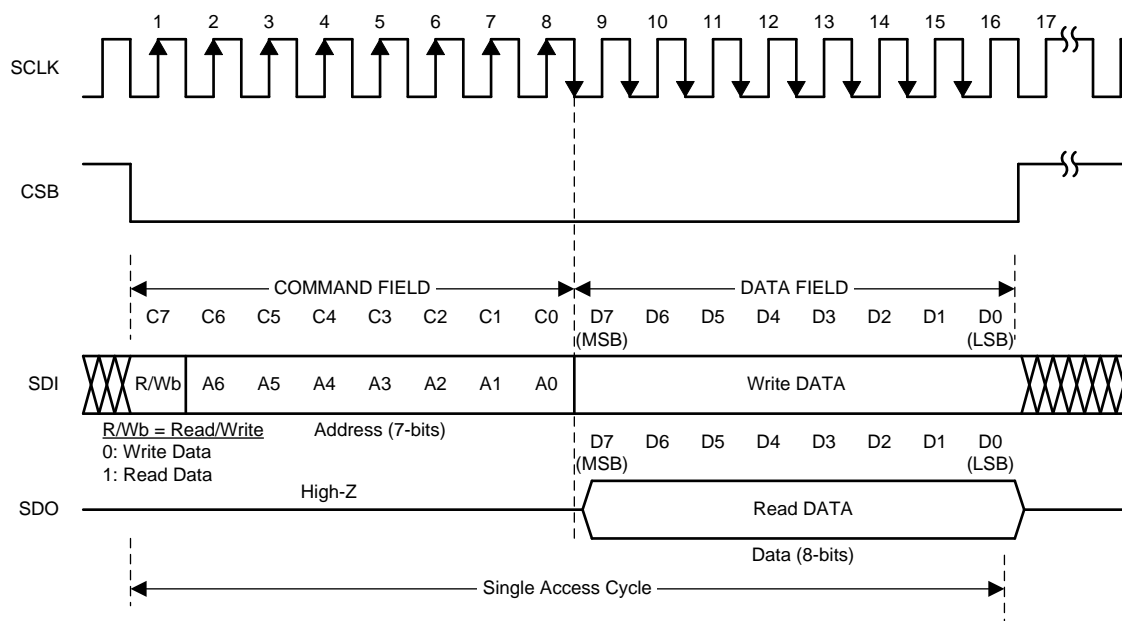

**Figure 17. Serial Interface Protocol**

Each assertion of chip select bar (CSB) starts a new register access. The R/Wb bit in the command field configures the direction of the access; a value of 0 indicates a write operation and a value of 1 indicates a read operation. All output data is driven on the falling edge of the serial clock (SCLK), and all input data is sampled on the rising edge of the serial clock (SCLK). Data is written into the register on the rising edge of the 16th clock. It is required to deassert CSB after the 16th clock; if CSB is deasserted before the 16th clock, no data write will occur.

### Extended SPI Transactions

A transaction may be extended to multiple registers by keeping the CSB asserted beyond the stated 16 clocks. In this mode, the register addresses increment automatically. CSB must be asserted during  $8 \cdot (1+N)$  clock cycles of SCLK, where N is the amount of bytes to write or read during the transaction.

During an extended read access, SDO outputs the register contents every 8 clock cycles after the initial 8 clocks of the command field. During an extended write access, the data is written to the registers every 8 clock cycles after the initial 8 clocks of the command field.

Extended transactions can be used to read 16-bits of Proximity data and 24-bits of frequency data all in one SPI transaction by initiating a read from register 0x21.

### INTB Pin Modes

The INTB pin is a configurable output pin which can be used to drive an interrupt on an MCU. The LDC1000 provides three different modes on INTB Pin:

1. Comparator Mode
2. Wake-Up Mode
3. DRDY Mode

LDC1000 has a build-in High and Low trigger threshold registers which can be as a comparator with programmable hysteresis or a special mode which can be used to wake-up an MCU. These modes are explained in detail below.

#### Comparator Mode

In the Comparator mode, the INTB pin is asserted or de-asserted when the proximity register value increases above Threshold High or decreases below Threshold Low registers respectively. In this mode, the LDC1000 essentially behaves as a proximity switch with programmable hysteresis.

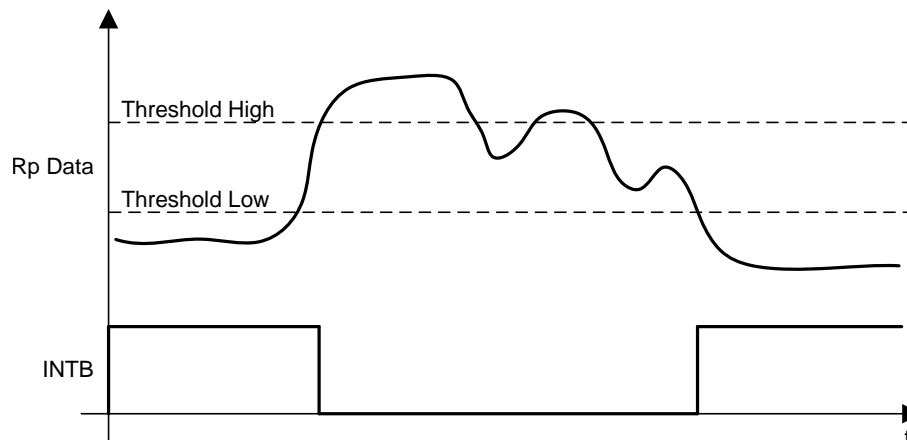

**Figure 18. Behavior of INTB Pin in Comparator Mode**

### Wake-Up Mode

In Wake-Up mode, the INTB pin is asserted when proximity register value increases above Threshold High and de-asserted when wake-up mode is disabled in INTB pin mode register.

This Mode can be used to wake-up an MCU which is asleep, to conserve power.

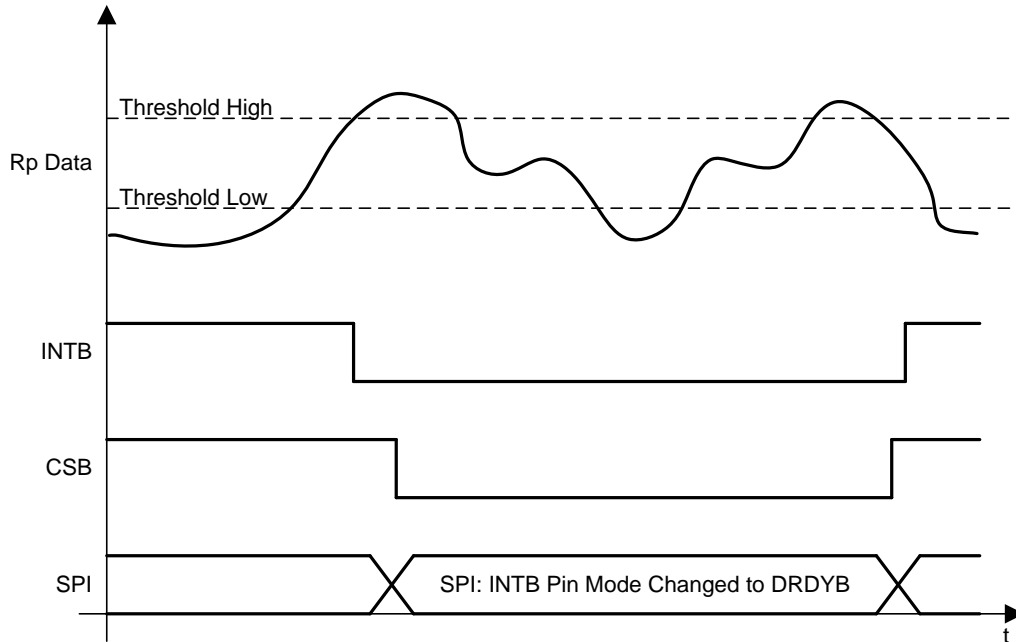

Figure 19. Behavior of INTB Pin in Wake-Up Mode

### DRDYB Mode

In DRDY mode (default), the INTB pin is asserted every time the conversion data is available and de-asserted once the read command on register 0x21 is registered internally; if the read is in progress, the pin is pulsed instead.

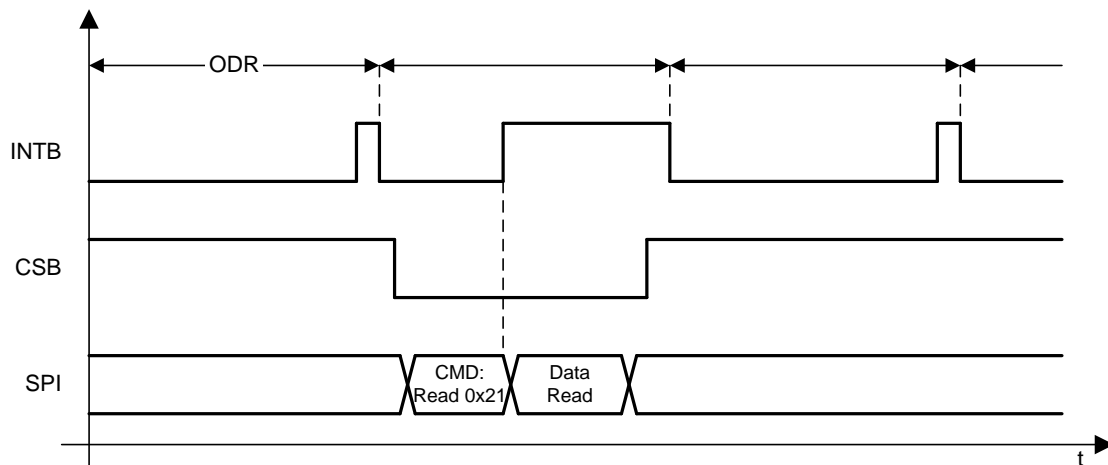

Figure 20. Behavior of INTB Pin in DRDYB Mode

TYPICAL APPLICATIONS

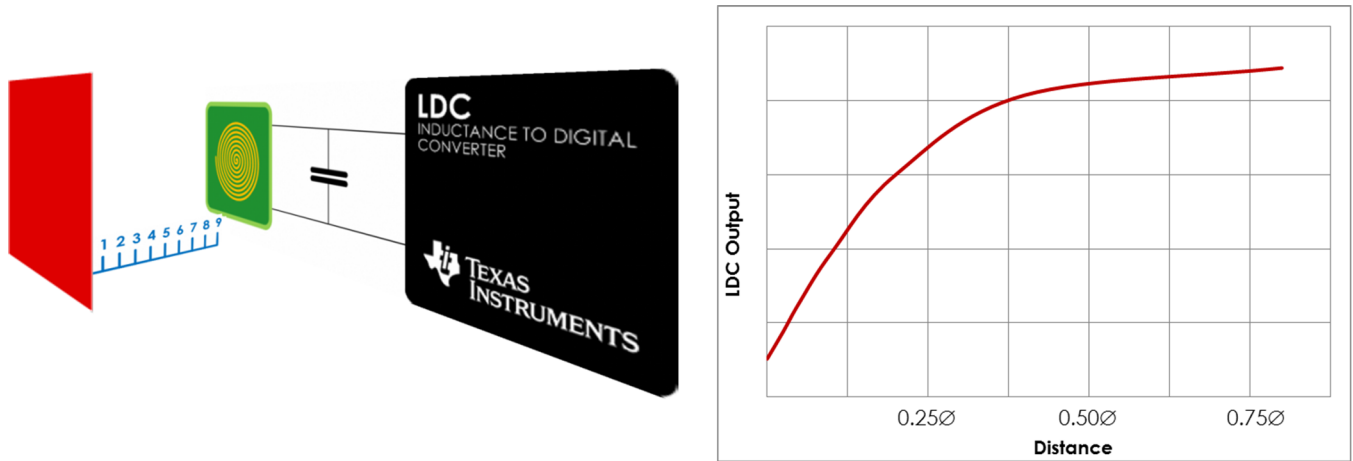

Figure 21. Axial Distance Measurement

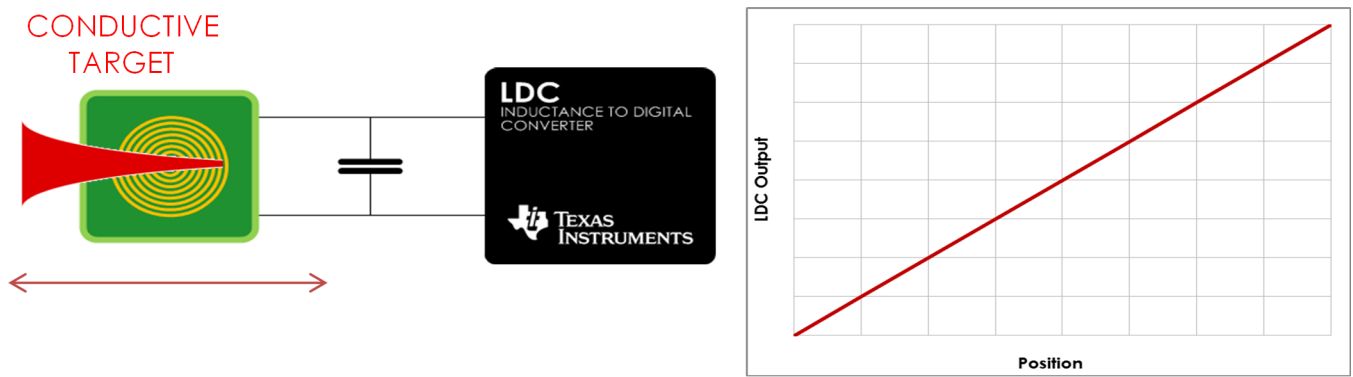

Figure 22. Linear Position Sensing

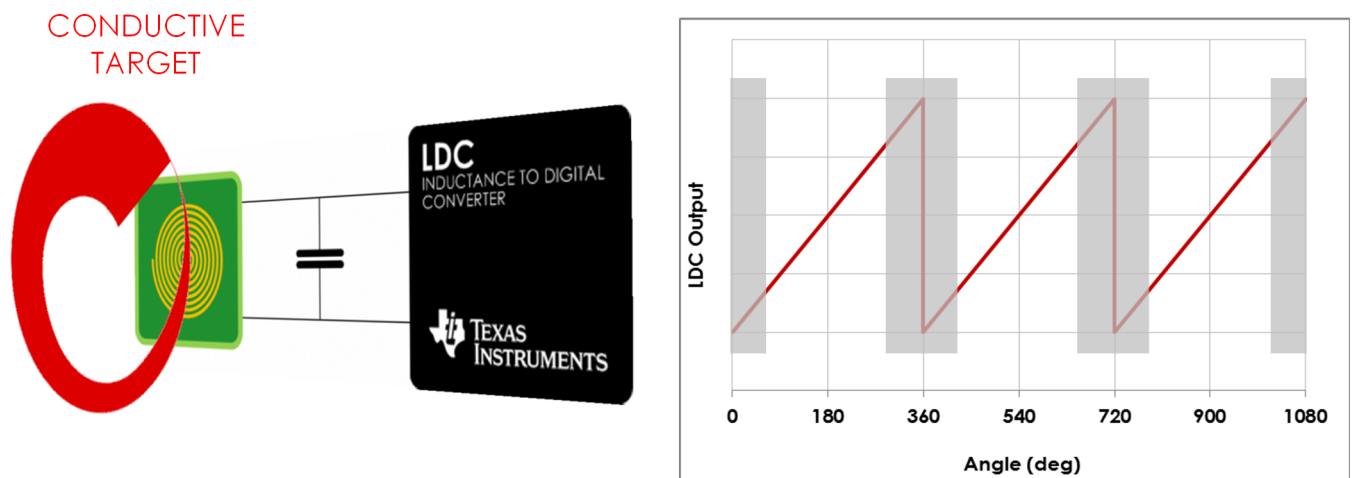

Figure 23. Angular Position Sensing

**PACKAGING INFORMATION**

Orderable Device	Status (1)	Package Type	Package Drawing	Pins	Package Qty	Eco Plan (2)	Lead/Ball Finish	MSL Peak Temp (3)	Op Temp (°C)	Device Marking (4/5)	Samples
LDC1000NHRJ	ACTIVE	WSON	NHR	16	4500	Green (RoHS & no Sb/Br)	CU SN	Level-1-260C-UNLIM	-40 to 125	LDC1000	<a href="#">Samples</a>
LDC1000NHRR	ACTIVE	WSON	NHR	16	1000	Green (RoHS & no Sb/Br)	CU SN	Level-1-260C-UNLIM	-40 to 125	LDC1000	<a href="#">Samples</a>
LDC1000NHRT	ACTIVE	WSON	NHR	16	250	Green (RoHS & no Sb/Br)	CU SN	Level-1-260C-UNLIM	-40 to 125	LDC1000	<a href="#">Samples</a>

(1) The marketing status values are defined as follows:

**ACTIVE:** Product device recommended for new designs.

**LIFEBUY:** TI has announced that the device will be discontinued, and a lifetime-buy period is in effect.

**NRND:** Not recommended for new designs. Device is in production to support existing customers, but TI does not recommend using this part in a new design.

**PREVIEW:** Device has been announced but is not in production. Samples may or may not be available.

**OBSOLETE:** TI has discontinued the production of the device.

(2) Eco Plan - The planned eco-friendly classification: Pb-Free (RoHS), Pb-Free (RoHS Exempt), or Green (RoHS & no Sb/Br) - please check <http://www.ti.com/productcontent> for the latest availability information and additional product content details.

**TBD:** The Pb-Free/Green conversion plan has not been defined.

**Pb-Free (RoHS):** TI's terms "Lead-Free" or "Pb-Free" mean semiconductor products that are compatible with the current RoHS requirements for all 6 substances, including the requirement that lead not exceed 0.1% by weight in homogeneous materials. Where designed to be soldered at high temperatures, TI Pb-Free products are suitable for use in specified lead-free processes.

**Pb-Free (RoHS Exempt):** This component has a RoHS exemption for either 1) lead-based flip-chip solder bumps used between the die and package, or 2) lead-based die adhesive used between the die and leadframe. The component is otherwise considered Pb-Free (RoHS compatible) as defined above.

**Green (RoHS & no Sb/Br):** TI defines "Green" to mean Pb-Free (RoHS compatible), and free of Bromine (Br) and Antimony (Sb) based flame retardants (Br or Sb do not exceed 0.1% by weight in homogeneous material)

(3) MSL, Peak Temp. -- The Moisture Sensitivity Level rating according to the JEDEC industry standard classifications, and peak solder temperature.

(4) There may be additional marking, which relates to the logo, the lot trace code information, or the environmental category on the device.

(5) Multiple Device Markings will be inside parentheses. Only one Device Marking contained in parentheses and separated by a "~" will appear on a device. If a line is indented then it is a continuation of the previous line and the two combined represent the entire Device Marking for that device.

**Important Information and Disclaimer:** The information provided on this page represents TI's knowledge and belief as of the date that it is provided. TI bases its knowledge and belief on information provided by third parties, and makes no representation or warranty as to the accuracy of such information. Efforts are underway to better integrate information from third parties. TI has taken and continues to take reasonable steps to provide representative and accurate information but may not have conducted destructive testing or chemical analysis on incoming materials and chemicals. TI and TI suppliers consider certain information to be proprietary, and thus CAS numbers and other limited information may not be available for release.

In no event shall TI's liability arising out of such information exceed the total purchase price of the TI part(s) at issue in this document sold by TI to Customer on an annual basis.



**TAPE AND REEL INFORMATION**

**QUADRANT ASSIGNMENTS FOR PIN 1 ORIENTATION IN TAPE**

\*All dimensions are nominal

Device	Package Type	Package Drawing	Pins	SPQ	Reel Diameter (mm)	Reel Width W1 (mm)	A0 (mm)	B0 (mm)	K0 (mm)	P1 (mm)	W (mm)	Pin1 Quadrant
LDC1000NHRJ	WSON	NHR	16	4500	330.0	12.4	4.3	5.3	1.3	8.0	12.0	Q1
LDC1000NHRR	WSON	NHR	16	1000	178.0	12.4	4.3	5.3	1.3	8.0	12.0	Q1
LDC1000NHRT	WSON	NHR	16	250	178.0	12.4	4.3	5.3	1.3	8.0	12.0	Q1

**TAPE AND REEL BOX DIMENSIONS**

\*All dimensions are nominal

Device	Package Type	Package Drawing	Pins	SPQ	Length (mm)	Width (mm)	Height (mm)
LDC1000NHRJ	WSON	NHR	16	4500	367.0	367.0	35.0
LDC1000NHRR	WSON	NHR	16	1000	210.0	185.0	35.0
LDC1000NHRT	WSON	NHR	16	250	210.0	185.0	35.0

NHR0016B

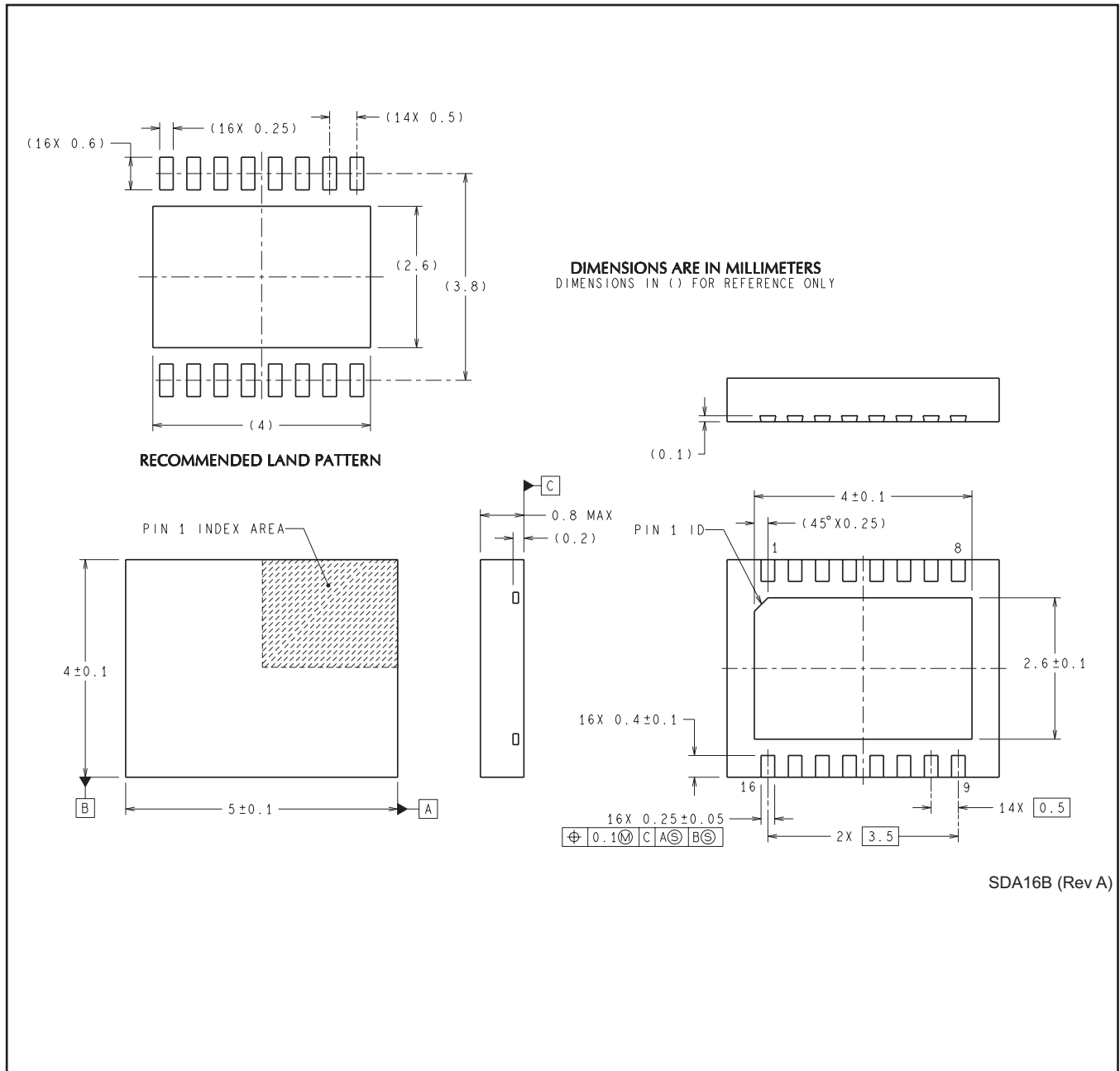

## IMPORTANT NOTICE

Texas Instruments Incorporated and its subsidiaries (TI) reserve the right to make corrections, enhancements, improvements and other changes to its semiconductor products and services per JESD46, latest issue, and to discontinue any product or service per JESD48, latest issue. Buyers should obtain the latest relevant information before placing orders and should verify that such information is current and complete. All semiconductor products (also referred to herein as "components") are sold subject to TI's terms and conditions of sale supplied at the time of order acknowledgment.

TI warrants performance of its components to the specifications applicable at the time of sale, in accordance with the warranty in TI's terms and conditions of sale of semiconductor products. Testing and other quality control techniques are used to the extent TI deems necessary to support this warranty. Except where mandated by applicable law, testing of all parameters of each component is not necessarily performed.

TI assumes no liability for applications assistance or the design of Buyers' products. Buyers are responsible for their products and applications using TI components. To minimize the risks associated with Buyers' products and applications, Buyers should provide adequate design and operating safeguards.

TI does not warrant or represent that any license, either express or implied, is granted under any patent right, copyright, mask work right, or other intellectual property right relating to any combination, machine, or process in which TI components or services are used. Information published by TI regarding third-party products or services does not constitute a license to use such products or services or a warranty or endorsement thereof. Use of such information may require a license from a third party under the patents or other intellectual property of the third party, or a license from TI under the patents or other intellectual property of TI.

Reproduction of significant portions of TI information in TI data books or data sheets is permissible only if reproduction is without alteration and is accompanied by all associated warranties, conditions, limitations, and notices. TI is not responsible or liable for such altered documentation. Information of third parties may be subject to additional restrictions.

Resale of TI components or services with statements different from or beyond the parameters stated by TI for that component or service voids all express and any implied warranties for the associated TI component or service and is an unfair and deceptive business practice. TI is not responsible or liable for any such statements.

Buyer acknowledges and agrees that it is solely responsible for compliance with all legal, regulatory and safety-related requirements concerning its products, and any use of TI components in its applications, notwithstanding any applications-related information or support that may be provided by TI. Buyer represents and agrees that it has all the necessary expertise to create and implement safeguards which anticipate dangerous consequences of failures, monitor failures and their consequences, lessen the likelihood of failures that might cause harm and take appropriate remedial actions. Buyer will fully indemnify TI and its representatives against any damages arising out of the use of any TI components in safety-critical applications.

In some cases, TI components may be promoted specifically to facilitate safety-related applications. With such components, TI's goal is to help enable customers to design and create their own end-product solutions that meet applicable functional safety standards and requirements. Nonetheless, such components are subject to these terms.

No TI components are authorized for use in FDA Class III (or similar life-critical medical equipment) unless authorized officers of the parties have executed a special agreement specifically governing such use.

Only those TI components which TI has specifically designated as military grade or "enhanced plastic" are designed and intended for use in military/aerospace applications or environments. Buyer acknowledges and agrees that any military or aerospace use of TI components which have **not** been so designated is solely at the Buyer's risk, and that Buyer is solely responsible for compliance with all legal and regulatory requirements in connection with such use.

TI has specifically designated certain components as meeting ISO/TS16949 requirements, mainly for automotive use. In any case of use of non-designated products, TI will not be responsible for any failure to meet ISO/TS16949.

### Products

Audio	<a href="http://www.ti.com/audio">www.ti.com/audio</a>
Amplifiers	<a href="http://amplifier.ti.com">amplifier.ti.com</a>
Data Converters	<a href="http://dataconverter.ti.com">dataconverter.ti.com</a>
DLP® Products	<a href="http://www.dlp.com">www.dlp.com</a>
DSP	<a href="http://dsp.ti.com">dsp.ti.com</a>
Clocks and Timers	<a href="http://www.ti.com/clocks">www.ti.com/clocks</a>
Interface	<a href="http://interface.ti.com">interface.ti.com</a>
Logic	<a href="http://logic.ti.com">logic.ti.com</a>
Power Mgmt	<a href="http://power.ti.com">power.ti.com</a>
Microcontrollers	<a href="http://microcontroller.ti.com">microcontroller.ti.com</a>
RFID	<a href="http://www.ti-rfid.com">www.ti-rfid.com</a>
OMAP Applications Processors	<a href="http://www.ti.com/omap">www.ti.com/omap</a>
Wireless Connectivity	<a href="http://www.ti.com/wirelessconnectivity">www.ti.com/wirelessconnectivity</a>

### Applications

Automotive and Transportation	<a href="http://www.ti.com/automotive">www.ti.com/automotive</a>
Communications and Telecom	<a href="http://www.ti.com/communications">www.ti.com/communications</a>
Computers and Peripherals	<a href="http://www.ti.com/computers">www.ti.com/computers</a>
Consumer Electronics	<a href="http://www.ti.com/consumer-apps">www.ti.com/consumer-apps</a>
Energy and Lighting	<a href="http://www.ti.com/energy">www.ti.com/energy</a>
Industrial	<a href="http://www.ti.com/industrial">www.ti.com/industrial</a>
Medical	<a href="http://www.ti.com/medical">www.ti.com/medical</a>
Security	<a href="http://www.ti.com/security">www.ti.com/security</a>
Space, Avionics and Defense	<a href="http://www.ti.com/space-avionics-defense">www.ti.com/space-avionics-defense</a>
Video and Imaging	<a href="http://www.ti.com/video">www.ti.com/video</a>

### TI E2E Community

[e2e.ti.com](http://e2e.ti.com)