



DP60-960T3C1L29WDDV

Coil before installation in the case

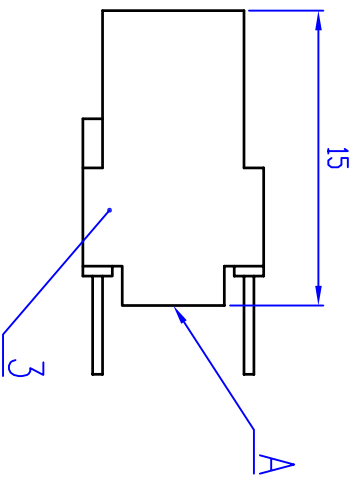
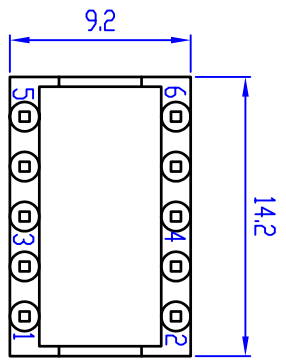
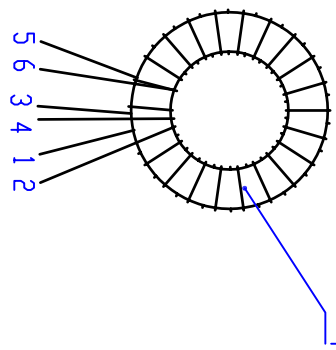
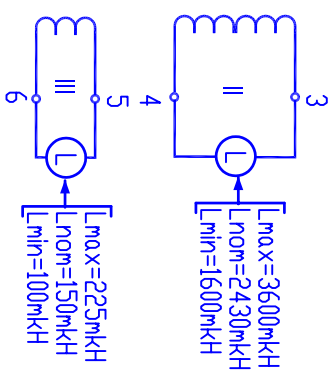
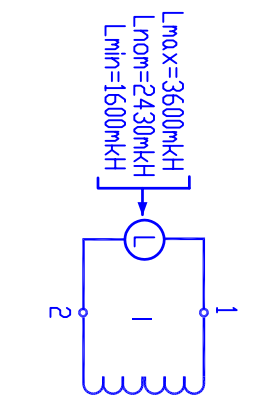

Table 1 Windings characteristics

Winding number	Pos.	Number of winds	Windings types	
			Number	Wire type
I	7	36	1,2	Winding wire
II	7	36	3,4	Winding wire
III	8	9	5,6	Winding wire

- \*Reference dimensions.
- Place the windings uniformly along the perimeter of the ring. Put the technological labels on the outlets.
- Install winding in cover pos.3 and seal it hermetically with elastosil RT601 (602) "Wacker".
- Windings outlets shear to necessary length, clean out at a distance not exceeding 5 mm, tin with the Solder X39, unsolder outlets. Before that wind in 2-3 tinned winds on the pin of cover pos.3. Soldering should not to overstep the limits of size A.
- Unused outlets cut up to base.
- Checking of transformer assemblage accuracy: nducance of connected together windings 1-2\_3-4\_5-6 should be 12300uH +4000 -3000.
- Transformer must be tested with alternating current voltage with mean-square value of 0.5 kV with frequency range in limits of 45...65 Hz. Voltage must be applied during 1 minute between transformer outputs 1,2; 3,4 and 5,6. Arcing, disruptive discharge and disruption should not occur during testing.



Mod	Sheet	DocumN	Sign	Date
Develop.		Matusar		36.05.03
Check		Banarsku		
T. control		Deev		
N. contro				
Approv.		Snavchikn		

ADDM.671331.096-03AD

Transformer  
Assebl drawing

ADD

Letter Mass Scale  
4:1

Sheet Sheets 1